



IMMERSION BLENDER XM-21 230/50-60/1

Professional immersion blender. 300 W.



P/N 3030625



SALES DESCRIPTION

- ✓ Variable speed motor block.
- ✓ 250 mm detachable arm.
- ✓ Designed for continuous use in recipients of up to 12 l.

All-in-one

- ✓ Professional hand blender designed for carrying out different preparations without the need for add-on tools.
- ✓ Professional Y-blade, made from tempered steel and with a long-duration cutting edge.
- ✓ Vario-speed: variable speed.
- ✓ Designed to work in recipients of up to 12 litres.

Maximum comfort for the user

- ✓ Compact design: logical and manageable size.
- ✓ Ergo-design & bi-mat-grip: external casing made in two materials for an ergonomic hold. Anti-slip grip. Optimum inclination of handle, minimising fatigue.
- ✓ Click-on-arm: detachable arm with fast and secure closure.
- ✓ Hood designed to avoid splashes.
- ✓ Intuitive use: very simple operation. Warning light when the machine is connected to the mains.

Built to last

- ✓ Professional performance: capable of carrying out prolonged work without the casing overheating.
- ✓ Life-plus: equipped with a motor which has passed all of the most demanding usage tests.
- ✓ Studied geometry: casing designed to avoid rolling and falling.
- ✓ Easy to clean: detachable arm, can be cleaned under the tap.
- ✓ Approved by NSF: guaranteed safety and hygiene.

INCLUDES

- ✓ Variable speed motor block.
- ✓ MA-21 mixer arm.
- ✓ Wall mount.

OPTIONAL

- MA-22 mixer arm.
- Whisk BA-20.

ACCESSORIES

- Mixer arms MA-20
- Whisk BA-20

SPECIFICATIONS

Total loading: 300 W
Maximum recipient capacity: 12 l
Motor speed: 1500 - 15000 rpm
Blade guard diameter: 82 mm
Electrical supply: 230 V / 50-60 Hz / 1 ~ (1.5 A)
Plug: EU (SCHUKO 2P)

Length

Liquidising arm length: 250 mm
Total length: 514 mm

Net weight: 2.31 Kg
Noise level (1m.): <80 dB(A)

Crated dimensions

440 x 375 x 105 mm
Gross weight: 2.91 Kg

DYNAMIC PREPARATION
COMMERCIAL HAND BLENDERS

product sheet
updated 21/04/2022



SAMMIC S.L.
Basaite, 1 - 20720 Azzovita
www.sammic.com



IMMERSION BLENDER XM-21 230/50-60/1

Professional immersion blender. 300 W.



P/N 3030625

DYNAMIC PREPARATION
COMMERCIAL HAND BLENDERS

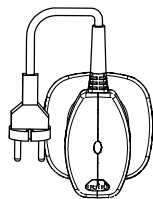
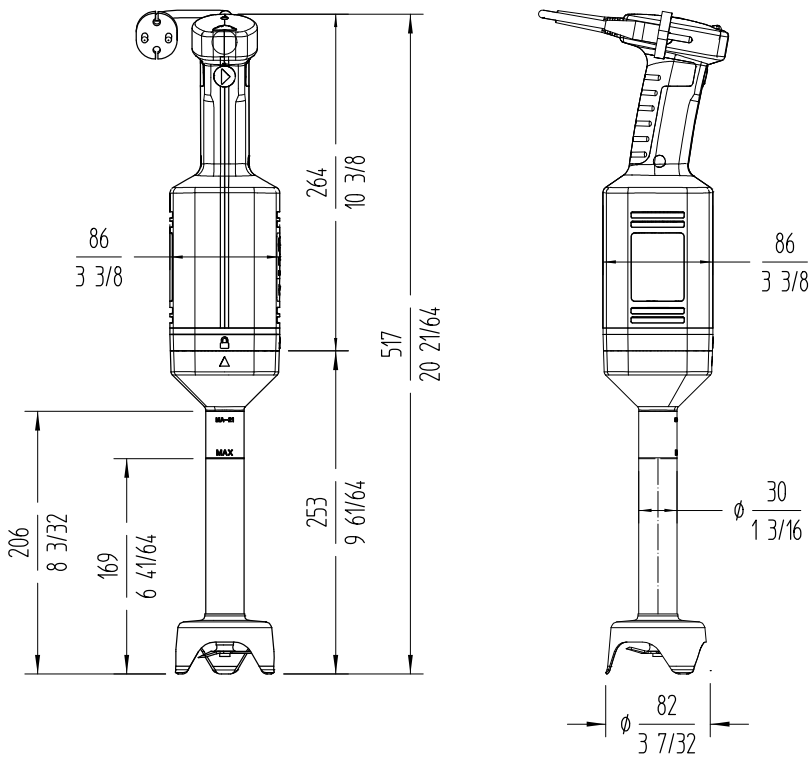

sammic | www.sammic.com
Food Service Equipment Manufacturer

Polígono Basarte, 1. phone +34 943 15 72 36
20720 Azkoitia, Spain sales@sammic.com



Project	Date
Item	Qty
Approved	

product sheet
updated 21/04/2022