

WALLKE

Wallkebike.com 



H9 AWD



**OWNERS
MANUAL**

Thank You For Purchasing Wallke Ebike!

We take pride in bringing you a quality product that will offer years of enjoyment. Please read and understand this manual fully before assembling and riding your bike.

If you have questions after reading this manual, please contact us by email, or give us a call on the phone.

We Are Here To Help!

- 🌐 **Wallke Ebike Website:** www.wallkeebike.com
- ✉ **Website Service Email:** sales@wallkeebike.com
- ✉ **Amazon Service Email:** info@wallkeebike.com
- 📞 **Phone:** 1-323-841-3459

Please attention that Wallke ebike have several sales channels now. Choose the right one to get connected! Email is preferred. Please send your purchase date and order ID so that we can handle your issue faster. Feel free to give us a call when needed.

Order ID: You can find this in the order history of the account the purchase was made through.

Thanks For Riding Wallke Ebike!

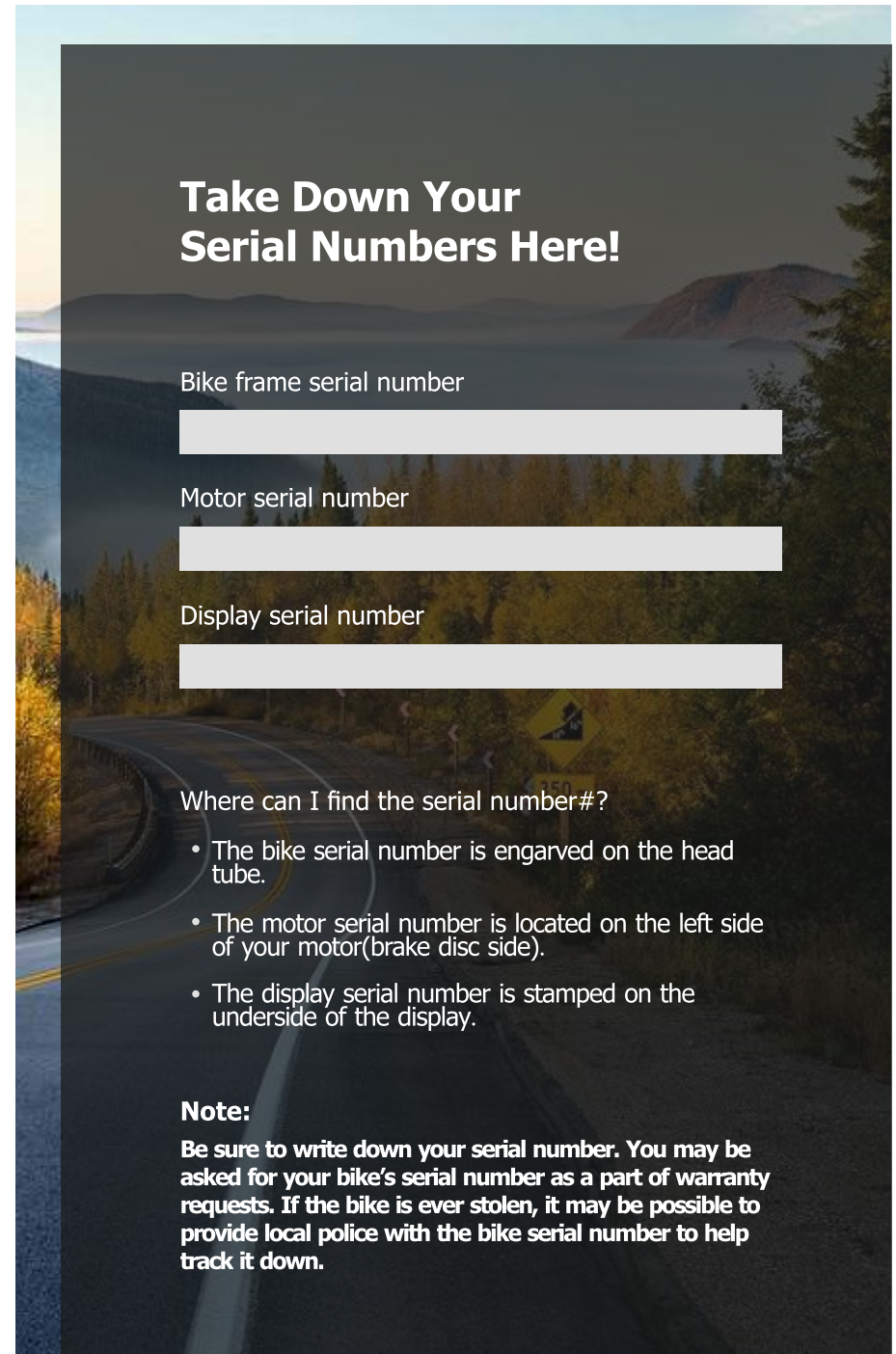

Take Down Your Serial Numbers Here!

Bike frame serial number

Motor serial number

Display serial number

Where can I find the serial number#?

- The bike serial number is engraved on the head tube.
- The motor serial number is located on the left side of your motor(brake disc side).
- The display serial number is stamped on the underside of the display.

Note:
Be sure to write down your serial number. You may be asked for your bike's serial number as a part of warranty requests. If the bike is ever stolen, it may be possible to provide local police with the bike serial number to help track it down.

Where Can I Find My Ebike's Serial Number?

Every bike receives a unique code, serving as a means of identifying a single bike against those of the same model. With this number we can manage the bicycle's warranty in case of a problem, identify the exact model with its year of manufacture or, in the worst case scenario, file a complaint in case of theft, among other things.



- 1.You will likely find your serial number on the motor itself. To locate it, start on the left side of your motor (the brake disc side).
- 2.The display serial number can be found at the back of the display.
- 3.The serial number is engraved on the head tube.



IMPORTANCE

Please read this owner's handbook carefully before using your H9 AWD in order to become thoroughly familiar with the correct operation of your bike's controls, its features, capabilities, and limitations. This handbook includes safe riding tips, but does not contain any of the techniques and skills necessary to ride an electric bicycle safely.

This owner's handbook includes assembly and maintenance work which may need to be done at frequent intervals to maintain an operational and safe H9 AWD. Never perform work on your H9 AWD beyond instructions in this handbook. This handbook is not intended as a comprehensive use, service, repair or maintenance handbook. Do NOT ride your H9 AWD if it has been assembled incorrectly. Maintenance beyond what the owner's handbook instructs is to be handled by an E-Bike specialist or professional cycle mechanic. Riding an incorrectly assembled bike can put your own safety at risk as well as others.

Liability Disclaimer:

Riding any kind of bicycle comes with inherent risks and dangers that cannot be predicted or avoided. These dangers could result in a serious accident, injury, or death of the rider. It is the sole responsibility of the rider to become properly educated and prepared to ride safely. Once in possession of the bike, Wallke eBikes strongly encourages and recommends that all customers have a certified and reputable bicycle mechanic complete a full inspection of each component on the bicycle to ensure it is safe for operation. Before every ride fully inspect your bicycle to ensure everything is secured and adjusted properly.

Under no circumstances is Wallke eBikes responsible for any damage resulting from damaged, defective, or improperly secured parts. This includes, but is not limited to, damage to personal property, personal injury, or death.

▲ Disclaimer: Must be 18 years of age or older to ride

TABLE OF CONTENTS

IMPORTANCE P4

COMPLIANCE WITH THE LAW P6

OPERATING INSTRUCTIONS P7

UNDERSTANDING YOUR H9 AWD P9

UNBOXING P10

ASSEMBLY P14

ADJUSTING THE FRONT SUSPENSION P21

TOOLS AND TORQUE SPECIFICATIONS P23

OPERATING YOUR NEW E-BIKE P24

H9 AWD DISPLAY P25

GENERAL OPERATION P31

ADVANCED SETTINGS P38

BLUETOOTH FUNCTION P41

KEY-DISP APP GUIDE P43

CARE & MAINTENANCE FOR YOUR NEW E-BIKE P48

SAFETY TIPS P51

BATTERY SAFETY P52

H9 AWD SPECIFICATIONS P54

GENERAL TROUBLESHOOTING P55

ERROR CODES & TROUBLESHOOTING P56

WARRANTY P57

PLEASE NOTE:

This manual is not intended as a detailed user, service, repair or maintenance manual. Please seek assistance from a qualified technician for service, repairs or maintenance.

COMPLIANCE WITH THE LAW

Read This First: Safety And Compliance With The Law

Congratulations on your purchasing of your new e-bike. Your new e-bike is an excellent piece of personal transportation equipment that will give you good service for many years.

Before you start using your e-bike, we want you to be aware of a few important points. Please read this section carefully..

● **Observe Laws Regarding The Use Of Battery-Operated Bicycles**

Your e-bike is designed and manufactured to meet safety requirements as a battery-operated bicycle. However, state and local laws governing the use of battery-operated bicycles on public roadways, parks, and other open areas may differ. Please check with your local authority before using your e-bike in public areas.

● **Observe Laws Regarding the Use of Bicycles**

Note that all laws regarding the use of bicycles in public areas, such as those mandating the use of helmets and the use of infant seats, will automatically apply for e-bikes. Check with your local authority on what restrictions might apply.

● **The Lithium-ion Battery Of Your E-Bike**

Your e-bike is equipped with the latest battery technology. The lithium-ion battery is much lighter than lead- or nickel-based batteries that are being used in some older models.

● **Your First Ride**

Please be VERY CAREFUL when you are ready to get on your e-bike for the first time because that the e-bike moves significantly faster than a regular bicycle at active power-assisted mode. Take your e-bike to an area with a lot of open space before you start. Do not start pedaling hard as soon as you get on the e-bike (as you normally would so with a regular bicycle), as the e-bike will accelerate under pedal-assist mode and you may be unprepared for the sudden increase in speed. However, after a few times, you will enjoy using the pedal-assisted function.

OPERATING INSTRUCTIONS

After the bike has been properly assembled according to the assembly video, all components are secured correctly, a certified, reputable mechanic has checked the assembly, and you have read this entire manual, turn on the bike and select a pedal assist level following the steps below:

When you buckle on your helmet and go for your first ride, be sure to pick an area away from cars, other cyclists, obstacles or other hazards in order to become familiar with the controls, features and performance of your new Electric Bike.

To get started, we recommend starting in PAS level 0 if you have never ridden an ebike before to get comfortable with the bike.

With the proper safety gear and rider knowledge, you may now operate your bike. On a flat surface, in a low gear (1 or 2) and rear wheel drive only, most riders should be able to begin pedaling the bike with pedal assist level 0 or 1. You may also use the throttle to accelerate and maintain your desired speed.



All-wheel drive



Eco power mode



Rear wheel drive



Front wheel drive

AWD ebike are typically heavier than regular mountain bikes because they have two motors, and therefore they handle differently. The dual-motor e-bikes with the double motor system, one in the front and the other in the rear, are suitable for different rides. Starting is much easier and faster than with a regular bike. Be careful these all-wheel drive settings are very powerful. It's a good idea to get familiar with the weight and power of your e-bike in an easy setting before hitting all-wheel drive.

Your bike has on demand all-wheel drive, at any time you can choose between front wheel, rear wheel, or all-wheel drive.

Recommended Rider Size:

You must ensure that you understand the safe operation of this bike and follow all traffic, bike laws and regulations in the area in which the bike is being operated.

No rider under the age of 18 should be permitted to use the bike. It is up to your discretion to know and understand if you are able to ride the bike safely.



UNDERSTANDING YOUR H9 AWD

Your H9 AWD is all-wheel drive, Class 3 eBike with a 1750 watt power drive system.

It's important to understand that the bike has two completely separate (but complimentary) drive systems:

- ◆ an electric drive system that powers the bike through the controller and/or throttle
- ◆ a seven-speed system you power by pedaling yourself

Although the two systems work independently, using them together is what makes the eBike experience so versatile and enjoyable.

Important note: Because your H9 AWD is a rear-hub drive, the gear system is for pedal power only, and has no effect on how the electric power system drives the bike.

● Name Of Each Part



UNBOXING

● Preparation Checklist

- ◆ Headlight
- ◆ Battery Charger
- ◆ Front Fender
- ◆ Battery(Pre-installed)
- ◆ 2 x Keys For The Battery(Tie on the handlebar)
- ◆ Saddle
- ◆ User Manual
- ◆ 1 x set of Pedals
- ◆ Tool Kits

Carefully check the package contents, if any parts are missing or damaged, please contact Wallke customer service immediately for assistance with providing your order ID#:

info@wallkeebike.com (Amazon/Walmart)

sales@wallkeebike.com (Wallke website)

It is recommended to retain the original packaging for a short period of time and keep it as intact as possible.

For warranty and returns, you are responsible for providing a new box at your expense if you have discarded the original box in which the product was shipped. PLEASE RETAIN YOUR BIKE BOX even if it has been damaged in shipping.

▲ Riding a bicycle is an inherently dangerous activity, and it is your responsibility to ride safely and within your abilities. Proper assembly is vital to the safe operation of your bicycle, so seek professional assistance if you are unable to complete the assembly of your bicycle as outlined in this manual.

Before assembling your bike, it is recommended to remove the battery for the following reasons:

- ◆ Determine if the battery is drained or damaged during the transportation.
 - ◆ Reduce the weight of the bike to make it easier to maneuver the bike when assembling.
- Avoid battery damage during assembly.

How To Remove The Battery?

● Rear Battery

- ◆ 1. Locate the seat quick release lever and turn over the saddle.
- ◆ 2. Insert the correct battery key, then turn counterclockwise to the "Lock/Unlock" position, as shown in the image(2).
- ◆ 3. After the locking pin has retracted, you should be able to pull out the battery.



To re-install the battery, align the slot at the side of the battery and reinsert it into the frame. No key is needed.

How To Charge The Battery?

The battery can be charged both mounted on the bike or separately from the bike. Two keys are supplied to unlock and lock the battery.

- ◆ Plug in the charger into a 120v wall outlet.
- ◆ Connect the charger cable to the battery charging port.

For your first ride, be sure to charge your battery until the light on your charger turns green, depicting a full charge.



We recommend charging the battery for 6-7 hours on the first charge. This will help condition the lithium-ion cells for optimal performance.

NOTE:

Never charge the battery in a flammable environment. For safety reasons, the charger and the battery must be placed on a dry, non-flammable surface.

How to Fold and Unfold your H9 AWD Electric Bike?

The Wallke H9 AWD folds in the center of the frame as well as at the handlebars. Instructions for folding and unfolding the bike can be found below:

● Handlebars

1. Pull the handlebar stem to its upright position.
2. Push the clasp down firmly so that it is locked in position. You should have to use enough force such that the clasp leaves an imprint in your palm. Pull on the clasp with your hand to confirm it is locked and the handlebars cannot fold.
3. To unlock the latch pull up on the black button labeled "open" .
4. Pull the clasp while still holding the "open" button up. You may now fold the stem.





● Pedals

1. To fold the pedals push in slightly.
2. Continue pushing down while raising it into its folded position.
3. The pedal will click into place once in the folded position.
4. To unfold the pedals, push the pedals down until you hear an audible click as they lock into the unfolded position.



● Frame

1. To unfold the bike frame, grab the handlebar stem and rear end of the bike while standing near where the battery is exposed. Lift the bike slightly off the ground and swing the bike to its closed position.
2. Push down on the clasp firmly until it locks into position. You should have to use enough force such that the clasp leaves an imprint in your palm. Pull on the clasp with your hand to confirm that the clasp has locked and the frame cannot fold.
3. To unlock the bike frame and return it to the folded position, start by sliding the switch labeled "open" to the right.
4. Pull the latch while still holding the switch to the "open" position. You may now fold the bike.



ASSEMBLY

Please read the instructions entirely before assembly to ensure the proper functioning of the H9 AWD. Failure to do so could result in serious personal injury or damage to the bike.

Assembly Instructions

● Step 1: Handlebar And Stem

1. Begin with handlebars in the folded down position.
2. Simply unfold the stem upward and press the latch inward until there is an audible click.
3. Give the latch a tug to ensure it is locked in place.
4. Push the clasp down firmly so that it is locked in position. You should have to use enough force such that the clasp leaves an imprint in your palm. Pull on the clasp with your hand to confirm it is locked and the handlebars cannot fold.

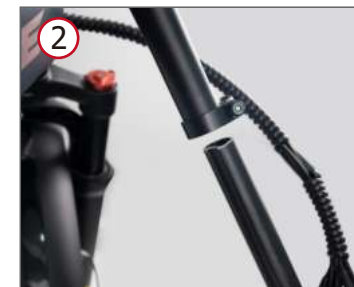

● **Step 2: Front Wheel(15 mm Open Wrench)**



Step 1. Locate the seat quick release lever and turn over the saddle.

Step 2. Insert the correct battery key, then turn counterclockwise to the "Lock/Unlock" position, as shown in the image(2). After the locking pin has retracted, you should be able to pull out the battery.



Step 3. Lay a mat down to protect both bike and floor from scratches. Lower the bike onto two foam from the box to protect and stabilize the handlebar. Next, carefully flip your bike upside down for the front wheel installation.

⚠ **Never charge the battery in a flammable environment. For safety reasons, the charger and the battery must be placed on a dry, non-flammable surface.**

⚠ **Please adjust the display to the suitable angle before rotating the bike. This reduces unexpected damage caused by improper rotating.**

Step 4. Remove the protective bar from the front fork, as shown in the image-(4). This black piece is used to protect the front fork from shaking during transportation.



Step 5. Pull out the red pad, which is used to protect the hydraulic brake caliper during transportation, as shown in the image-(5).

⚠ **Do not pull the brake lever without having either the red pad or the brake disc inserted, as this will damage the hydraulic brake caliper.**

Step 6. Find out the front wheel anti-rotation washers, located on the right(non-brake disc) side of the front wheel motor, as shown in the image-(6).



Step 7 & 8. Removed the both front wheel anti-rotation washers and axle bolts on the left and right sides, as shown in the image-(7-8).



Step 9&10: Please do not remove these inside washers. They should be placed in the innermost position, as shown in the image-(9)&(10).



Step 11&12. See the image-(11)&(12). They will show you where the washers are supposed to go. Please put the anti-rotation washers, anti-rotation washers and axle nuts to the correct place.



Step 13. Once the wheel, anti-turn washers and brake rotor are aligned on the fork tighten both axle nuts. Use a wrench to tighten the axle nuts firmly, as shown in the image-(13).

Step 14. Once the axle bolt was tightened properly, remove the Allen bolts from the anti-Torque Washer using an Allen wrench, as shown in the image-(14)



Step 15. Please put the motor cable into the anti-Torque Washer. Once the motor cable was secured properly, please tighten the anti-Torque washer bolts, as shown in the image-(15).



Step 17. Connect the front motor wire connectors together, Pay careful attention to the arrows on the wire connectors, making sure the arrows align with each other to avoid damaging the interior circuitry.

▲ Do not ride the ebike without having the motor cable tightening, as this will damage the motor cable or motor.

● Step 3: Front Fender And Headlight(4mm & 5mm Allen Screw Wrench)

The headlight and front fender are both secured by a single bolt, so the front fender should be installed together with the front light.

1. Unscrew and remove the bolt using the 5mm Allen screw wrench, and reinstall the headlight with the front fender together.
2. Tighten the bolt and connect the light wire(if it disconnects). Pay attention to the arrows on the wire connectors, making sure the arrows align with each other to avoid damaging the interior circuitry.
3. Remove the nuts and washers attached to the front fork which are used to fix the front fender, put the fender iron bar in the right place, then tighten the bolts using the 4mm Allen screw wrench.



● Step 4: Pedals(15 mm Open Wrench)

1. Look for a letter marking "L" "R" on each respective pedal and make sure you install the left pedal on the left crank, the right pedal on the right crank.
2. Thread the right pedal onto the right crank gently by hand, turning clockwise. Then tighten pedal by the wrench.
3. Thread the left pedal onto the left crank gently by hand, turning counter-clockwise. Then tighten pedal by Allen wrench.
4. Check the chain alignment. Rotate the right pedal and crank toward the back of the bike as though pedaling backward. Watch the chain and ensure the chain runs through the drivetrain (the rear cog, chain tensioner, and around the front chainring) smoothly

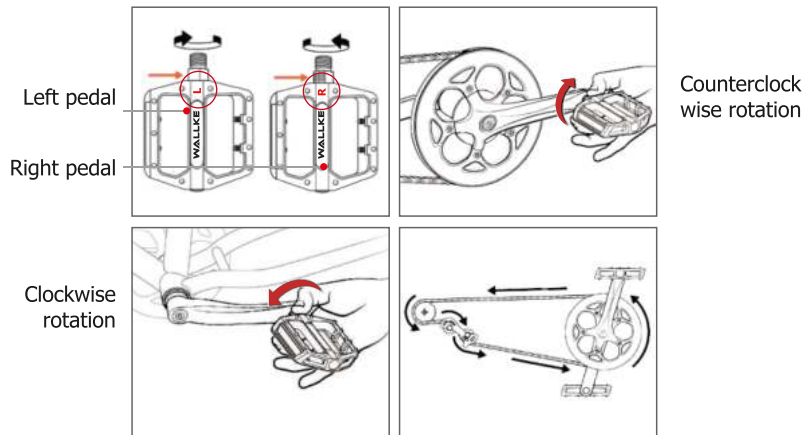

● Step 5: Rear Seat (Screwdriver)

1. Loosen clamp screw using screwdriver.
2. Push the rear seat down.
3. Forward to the direction as shown in the below picture(3).
4. Tighten the nuts with the screwdriver tool as shown in the below picture(4).



Using the Battery Keys: Unlock, Power On and OFF

Your bike comes with two identical keys to turn your battery on and off. These keys are unique to your bike. For help with lost keys, you may need to replace a new battery head.

The battery has 3 key positions: LOCKED, OFF, and ON. These positions are marked on the battery and can only be seen when the battery is removed from the bike.



● locked" position - remove the battery

Turn off the bike. Press and hold the power button on the LCD Display remote (or the power button on the LED remote) until the display turns off.

Use the key to turn off and unlock the battery. Insert the key into the key port, then push and rotate the key to the "locked" position. In this "LOCK" position, the battery pack will NOT be secured to the frame. Please aware the power will also not be active(lock position).



- **"OFF" position - disable the battery power**

In this "OFF" position, the battery pack will be secured to the frame, but the power will not be active.

Note: The key barrel must be in the on-and-locked position for the LEDs to light up.



- **"ON" position - The power will be active**

The power will be active, and the key will be locked into the battery so that it cannot be removed. The key must be turned to the ON position for your bicycle to function.

Note: Be careful not to drop or damage the battery when loose from the bike.

Do not touch the "+" and "-" terminal contacts on the bottom of the battery when the battery is removed from the bike.



Adjusting the Front Suspension

The firmness of the front suspension can be adjusted for balance between performance and ride comfort.

To adjust suspension firmness, turn the control knob at the top in the direction of the arrow that will increase or decrease the firmness of the ride.



Front Suspension Adjustment



- ◆ For maximum range, lockout the suspension by turning the dial all the way in the ⊕ direction.

Check that your suspension fork is properly adjusted for the terrain and your weight. The suspension fork will affect the handling of the bike, primarily when going over bumps and stopping. In some situations, it may be advantageous to lock out the suspension so it is fully rigid.

- ◆ **Note:** Intensive use of the H9 AWD may cause possible damage to the frame and the fork. It is important to inspect the frame and the fork and look for signs of cracks. A broken or cracked frame and fork can cause an accident and injury.

Note:

The brand of parts advertised on our website may vary depending on the ongoing supply chain constraints in the eBike market. Component changes may occur without prior notification. All parts have been carefully inspected to ensure they equal the performance standard of the products advertised.

Tools and torque specifications

The tool sizing listed below is a general guide, but it is possible that the head of a particular bolt on your ebike may vary requiring a different tool (e.g., a 4 mm Allen wrench instead of a 5 mm Allen wrench). If so use whatever tool fits the bolt head. Such differences will not affect the recommended torque for that piece of hardware.

HANDLEBAR AREA		
Stem faceplate bolts (four bolts)	5 mm Allen	8-10 Nm
Stem clamp bolts	5 mm Allen	13-15 Nm
Brake lever clamp bolt	5 mm Allen	6-9 Nm
Handlebar grip bolts	2 mm Allen	3-4 Nm
Throttle clamp bolt	3 mm Allen	2-3 Nm
FORK AND FRONT WHEEL AREA		
Headlight/front fender mounting bolt	4 mm Allen	6-8 Nm
Front axle nut	21 mm wrench	45-50 Nm
Brake rotor to hub bolt	T-25 Torx bit	6-8 Nm
Front wheel torque arm bolts	5 mm Allen	4 Nm
Brake pads to caliper	Needle-nose pliers	90° bend at tip of cotter pin
(SEAT AND BOTTOM BRACKET/CRANK AREA)		
Seat adjustment bolt	6 mm Allen	18-20 Nm
Pedal into crank arm	15 mm pedal wrench	35 Nm
Chainring bolts	6 mm Allen	8-10 Nm
Controller mounting bolts	5 mm Allen	2-3 Nm
Bottom bracket and cups	BBT-22 Park Tool	50-55 Nm

Please use the tool and the torque values appropriate for the component on your ebike.

OPERATING YOUR NEW E-BIKE





Powering Up Your eBike

To turn on the electric system and controller, press and hold the  button for 4 seconds.



To turn the system off, do the same. Press and hold the  button for 4 seconds. In addition, the system will turn itself off if the bike is still for 5 minutes. (This time can be changed in Display Settings.)



Your First Ride

You'll quickly get the feel for your bike and its electric system. For your first ride, you may want to follow these steps:

- 1) turn on the electric system and controller by holding the  button for four seconds.
- 2) If the bike is not showing mode , press the  button until it does (the electric mode is disabled).
- 3) Start off, riding the bike with pedal power.
- 4) When you're steady and stable, press the  button to set mode , enabling the electric assist.
- 5) Being ready for the bike's assist to come in, begin to pedal (after a pedal rotation or two, you will feel the assist come in).
- 6) When you're ready for the bike to move under electric power only, press the throttle slowly until the bike powers forward.
- 7) Brake to a stop when you're ready.

- ◆ The electric power system won't engage if the bike is already going faster than the mode  range (approximately 10 MPH /16 kph).

After your initial ride, you can experiment with higher modes, using the  and  buttons to change them.

(Remember: mode  will turn off the electric drive. Setting mode  or higher will turn it on again.)

Using The Pedal System

The pedal system will be familiar to nearly everyone, but there are a few practical things that can help you make the best use of it.

- ◆ You can select the best gear for your riding situation using the two buttons on the right handle bar.
(The best gear is the one that balances between having to push too hard and having to pedal so fast that you can't really push very much at all.)
- ◆ The gears will only change when you're pedaling forward, so be sure to do so when you're changing gears.
- ◆ A low gear is best for starting to move again after stopping, so be sure to gear down and you're slowing for stop. This will make starting up again much easier.
- ◆ Because your bike is a rear-hub drive model, the gears in the pedal drive system have no effect on the electric drive system.
- ◆ If you want to operate your bike a pedal-only mode, select Mode ⑩ . (see Operating Modes)

Using The Electric Drive System

The electric drive system can either fully power the bike without your assistance, or can provide assistance when you're pedaling.

PEDAL-ONLY

In this mode, the H9 AWD will perform like a normal bike, as you'll be riding without any assistance from the motor. This mode is especially useful if you run out of battery, or are looking for more intensive resistance training.

H9 AWD Display

Kd986 can provide a lot of functions to fit your needs. The indicating contents are as follows:

- Battery indicator
- PAS level adjustment and indicator
- Speed (incl. real speed, Max. speed and Avg. speed)
- Distance (Trip and ODO)
- 6km/h push assistance
- Riding time
- Backlight
- Error code
- USB connection
- BLE connection
- Various Parameters Settings (e.g., wheel size, speed-limit, battery voltage segmented values setting, PAS level parameters etc.)

General operations

● Key definition

Key K5, 5 buttons, ON/OFF, info, +, light, -/Walk boost.

Key K6, 6 buttons, ON/OFF, info, +/light, -/Walk boost, <(left) and >(right).

● Key options

Hold ON/OFF, + and - for 2s to enter the interface for key options. Press +/- to choose the desired key mode. Press ON/OFF button to save a changed setting and exit to home screen.



Key options

● ON/OFF

Press "ON/OFF" button for 2 seconds, the display will turn on and the whole system will start to work. When display is on, long press the "ON/OFF" button to turn off the power of the e-bike. When display is off, display no longer uses battery power and the off-leakage current is less than 1 μA.(K5 and K6 are the same for button operations)

- ◆ When parking the E-bike for more than 5 minutes, the E-bike system switches off automatically.

System Control

The electric power system and display are controlled with the handlebar control.

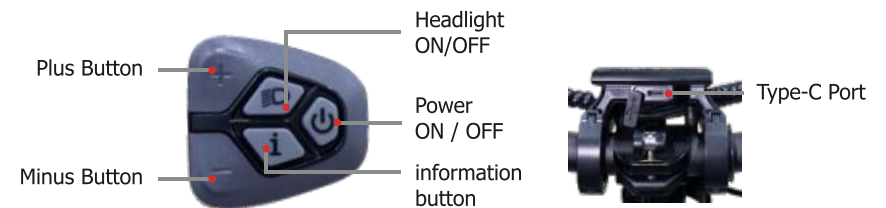

The ⊕ and ⊖ buttons set the electric power mode, and are also used in the settings panels.

The headlight button will switch the headlight on or off. (This system detects low light and will automatically switch on the headlight when needed.)

The ⏻ button powers up or powers down the electric system. (Press for 2 seconds to turn the system on or off.)

The ⓘ button cycles through the modes in the multi-function display.

Your H9 AWD has an USB Type-C charging ports.

It is under the display panel.

Display Settings

The display settings panel displays and can set the most common parameters you may need to change.

You can go to display settings by:

- 1) press and hold both the ⊕ and ⊖ buttons.
- 2) with DISPLAY SETTINGS highlighted.
- 3) press the ⓘ button to select.

Dormancy	number of minutes of non-use before the bike system turns itself off
TRIP Reset	used to reset the TRIP odometer
AL Sensitivity	/
Toggle Unit	set metric or imperial units
LCD Luminance	display brightness
Password	to require a password before the bike will operate, set the password here

Dormancy

This sets the inactivity time after which the electric system will power down.

TRIP Reset

Change this value to YES to reset the trip odometer. This also clears the MAX and AVG speeds.

AL Sensitivity

Ambient light sensitivity controls how the display responds to low-light environments. This value will determine the point at which the system senses low light and dims the display and turns on the headlight.

Toggle Unit

This determines whether the display operates in imperial or metric units.

LCD Luminance

Use this value to set the brightness of the digital display.

Password

Use this to set a password for the electric system on the bike. When a password is set, the electric system will request and require it before allowing electric operation.

Factory Restore

Use this to restore the control system to factory defaults.

- ◆ **Note:** Factory Restore will reset all the values on both the Display panel and the Advanced panel.

Changing Display Settings

- 1) Use the ⊕ or ⊖ buttons to move the highlight up or down.
- 2) Use the ⓘ button to select the highlighted item.
- 3) Once the item is selected, use the ⊕ or ⊖ buttons to change the item's value. When the desired value is reached, press the ⓘ button to lock in the value.
- 4) Select BACK to return to the higher menu or the main display.

Advanced Settings

The advanced settings panel contains factory setting not usually adjusted by riders. Use care and good judgement if you decide to change them.

You can go to advanced settings by:

- 1) press and hold both the ⊕ and ⊖ buttons.
- 2) press ⊖ to highlight ADVANCED SETTINGS.
- 3) select by pressing the ⓘ button.

This will bring the advanced setting up in display-only mode. To change the settings, see “Changing Advanced Settings” at the end of this section.

Wheel	size of drive wheel (including tire)
Speed Limit	maximum speed supported
Current Limit	maximum current allowed by the controller (this protects the motor and controller – changing this value can significantly reduce the life of both)
Speed Sensor	number of magnets in the speed sensor
Assistant Num	sensitivity of the assist systems
Set Voltage	controls how the battery charge display interprets the voltage levels of the battery
Power Set	number of modes available (sub-menu defines each mode’s max power %)
Slow Start	delay before motor begins to assist
SHD	must be 0% to protect the controller
CRU	cruise control ON/OFF

◆ **Note:** Some of the advanced settings configure the controller and display for the exact hardware of the bike. Changing these settings can cause the bike to malfunction, or could potentially damage certain components. Changing these settings is unlikely to improve the bike.

Wheel

This sets the size of the wheel for the purpose of calculating speed from wheel rotations. With the 4” fat tire, the 26” wheel behaves like a 28” wheel on this bike.

Speed Limit

This sets the upper limit of speed where power assist will be provided. You can set this to be consistent with local regulations.

Current Limit

This controls the automatic protection circuit in the controller so your battery and motor are protected. Changing this from the factory setting won’t improve the bike’s performance, but it will disable important protections designed to prevent very costly repairs.

Speed Sensor

This is factory set to let the controller know what type of speed sensor is used in the bike. Changing this will make the controller incapable of functioning properly.

Assistant Num

This sets the force provided by the power assist. The value ranges from 4 (greatest power provided for assist) to 24 (least power on assist). Think of these as setting how gentle the assist will be: 4 (not so gentle) to 24 (very gentle).

Set Voltage

Sets the behavior of the battery monitor as it translates battery voltage into the battery charge and percentage indicator on the display. Changing this from the factory settings will usually make the battery charge display less accurate.

Power Set

Changing your Power Set from the default 0-3 to 0-5 will give you more speed ranges to choose from when riding. As part of changing to a new power set, you can also change the percentage of total available power that drives each mode. These setting will control the approximate speed at the upper limit of each mode.

Other eBikes may come with different configurations, and you may decide to customize your Power Set for better compatibility with those of other riders, or to give you finer control of the speeds of the Power Set (modes and speed points) on your bike.

Slow Start

Slow Start sets the delay from the start of pedaling to the time the assist begins. Lowering this number will have the assist come in sooner, raising it will give a little more time for you to stabilize your effort before the system comes in.

GENERAL OPERATION

Definition of Button

The H9 AWD display matches the K43 remote, and there are 4 buttons: including on/off, I key, plus key/headlight key, minus key/boost key; in the subsequent instructions, the word "ON/OFF" is used for the on/off key Replacement; the i button is replaced by the word "i"; the plus/headlight button is replaced by the word "UP"; the minus/boost button is replaced by the word "DOWN".

Power on/off

After long pressing the "ON/OFF" button for 2 seconds, the display will turn on and the whole system will work normally. In the power-on state, long press the "ON/OFF" button to turn off the power of the e-bike.

◆ When parking the E-bike for more than 5 minutes, the E-bike system switches off automatically.

Display Interface

After switching on the E-bike system, the display will show Current speed, Dual drive mode and Trip Distance(KM), ODO (KM) as default. Pressing the "i" button to switch between following items:
 ODO (Km)→Max. Speed (Km/h)→ Avg. Speed (Km/h) →Riding Time (Min.) **(K5 and K6 are the same for button operations)**



Display interface



Walk boost

Keep holding - button, after 2 s, the ebike is activated to the walk boost mode and ebike moves at a uniform speed of 6km/h and screen shows icon "  ". when you release - button, ebike stops power output immediately and gets back to the status before walk boost is activated. **(K5 and K6 are the same for button operations)**



Walk boost

Light control

Key K5, press  for 2s to turn on the light and display backlight brightness lowers down. Press  again for 2 s to turn off the light and display backlight brightness recovers.



Bike light on

PAS level selection

Short press the "+" or "-" button to switch the pas level of the bike and change the output power of the motor. The default output power ranges from level 0 to level 5. PAS level 0 stops power output, PAS level 1 is the minimum power, PAS level 5 is the maximum power. As shown in the figure below, it is PAS level 1. **(K5 and K6 are the same for button operations)**



PAS level selection

Motor modes

Press i button for more than 2 s and you choose Dual/fron/rear, 3 drive modes. Dual mode is the default. (K5 and K6 are the same for button operations)



Dual drive



front drive



rear drive

USB connection

When USB device is connected to display, the connection icon is as follows:



front drive

BLE connection

When display connected with smartphone app, "Key-Disp". The connection icon is as follows:



BLE connection

Err code

When an err appears, display shows err codes. Please refer to attached lis for definition details.



Err interface

◆ When an error code is displayed, please repair the bike. Or else the e-bike will not be able to run normally.

Trip Reset

"TRIP Reset" is for clearing a trip distance. Press ⊕ / ⊖ to choose No (no clearing a trip distance) or Yes (clearing a trip distance). press ① to save a changed setting. Or hold i button to exit to home screen or use "BACK" → to home screen. When display is off or ebike is powered off, the TRIP data will not be automatically cleared.

Display Setting	
TRIP Reset	No
Unit	Metric
Brightness	100%
SOC View	Percent
Auto Off	5Min
AL Sensitivity	3
Set Voltage	48V
Password	>
Front Motor Temp	-30°C
Rear Motor Temp	-27°C
BACK	



Display Setting	
TRIP Reset	Yes
Unit	Metric
Brightness	100%
SOC View	Percent
Auto Off	5Min
AL Sensitivity	3
Set Voltage	48V
Password	>
Front Motor Temp	-30°C
Rear Motor Temp	-27°C
BACK	

Trip reset

Unit

“Unit” is for toggling between Metric (km) /Imperial (mile) .press ⊕ / ⊖ to choose the desired unit. The default is Metric (km). Press ① to save a changed setting.



Unit

Brightness

“Brightness” is the display backlight brightness setting. Press ⊕ / ⊖ to change the brightness. The range is 100%-75%-50%-30%-10%. 100% is the brightest and 10% is the minimum brightness. Press ① to save a changed setting.



Brightness

SOC View

“SOC View” is for the method for displaying the battery SOC. One is percent and the other is voltage value. Press ⊕ / ⊖ to choose your desired mode. Press ① button to save a changed setting. The default is Percent.



SOC View

Auto off

“Dormancy” is for turning off the display in a certain time duration. To set the duration, press ⊕ / ⊖ to choose from OFF, 1-9 mins. The default set is 5 mins. Press ① to save a changed setting.



Auto off

AL sensitivity

“AL Sensitivity” for setting the sensitivity for the light sensor. Press ⊕ / ⊖ to choose from 5-1 or OFF. The default is 3. press ① to save a changed setting.



AL sensitivity

Set voltage

“Set voltage” is for setting the battery voltage segmented values. The display only supports 48V. Press ① to switch between voltage segments. For example, 40 volt is the first the segment and you can change the value by pressing ⊕ / ⊖ . press ① to confirm and move to the next segment. After all 5 segments are completed, long press ① to confirm and save the settings.



Set voltage

Password

Press ⊕ / ⊖ to select Password and press i to enter the setting. Press ⓘ again to choose Start Password. Press ⊕ / ⊖ to switch between OFF and ON. See below.

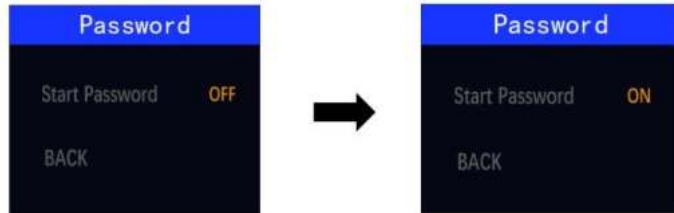

Password

- Password enable

After selecting "ON" in the "Start PassWord" interface, short press the "ⓘ" to confirm. The interface prompts for password input, short press the "⊕" or "⊖" to enter numbers, short press the "ⓘ" key to move to next digit, and after entering the 4-digit password, short press the "ⓘ" key to confirm; The interface prompts to enter the password again. After two consistent inputs, the system prompts that the password has been set successfully. If the two inputs are not consistent, you need to repeat the first step of entering a new password and confirm. After the password is set successfully, the interface will automatically jump to the original setting interface.

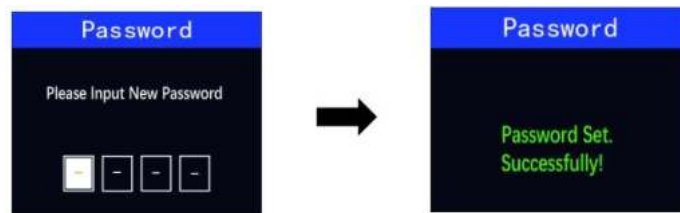

Password enable

- Password Reset

After password is started, the "Password" interface will add a "Reset Password" option. Short press "⊕" or "⊖" to select "Reset Password", and then short press "ⓘ" again to confirm. At this time, the interface will prompt for the current password. If the password is entered correctly, the interface will prompt for a new password. After the password is successfully modified, in 2S, the interface will automatically jump to the original setting interface.

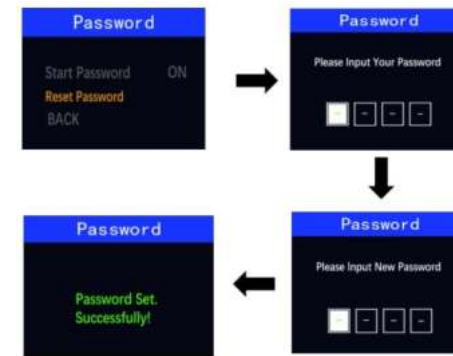

Password change

ADVANCED SETTINGS

Assist levels

"Assist levels" is for setting the assist level modes. 8 options: "0-3, 1-3, 0-5, 1-5, 0-7, 1-7, 0 -9, 1-9" . press ⊕ / ⊖ to choose your desired mode. Press ⓘ to confirm a changed setting.



Assist levels

Wheel

Wheel is for setting the wheel sizes. Press ⊕ / ⊖ to set the wheel sizes and the optional sizes are "16Inch, 18 Inch, 20 Inch, 22 Inch, 24 Inch, 26 Inch, 700C, 28Inch" . the default is 20 inch. Press ⓘ to save a changed setting.



Wheel

Speed limit

“**Speed Limit**” is for setting the speed limit. Press ⊕ / ⊖ to change the speed limit value. The optional value is 17-45 km/h. the default is 45km/h. press ① to save a changed setting.

Advanced Settings	
Assist Levels	0-5
Wheel	20Inch
Speed Limit	45km/h
Current Limit	25A
Speed Sensor	01
Assistant Num	12
Assistant Sensitivity	3
Slow Start	-1-
Throttle-6km	OFF
Throttle-PAS	ON
Motor Mode	F/R

Speed limit

Advanced Settings	
Assist Levels	0-5
Wheel	20Inch
Speed Limit	35km/h
Current Limit	25A
Speed Sensor	01
Assistant Num	12
Assistant Sensitivity	3
Slow Start	-1-
Throttle-6km	OFF
Throttle-PAS	ON
Motor Mode	F/R

Current limit

“**Current Limit**” is for setting the top current, press ⊕ / ⊖ to choose your desired value. The range is “7-30A”, the default is “25A”. Press ① to save a changed setting.

Advanced Settings	
Assist Levels	0-5
Wheel	20Inch
Speed Limit	45km/h
Current Limit	25A
Speed Sensor	01
Assistant Num	12
Assistant Sensitivity	3
Slow Start	-1-
Throttle-6km	OFF
Throttle-PAS	ON
Motor Mode	F/R

Current limit

Advanced Settings	
Assist Levels	0-5
Wheel	20Inch
Speed Limit	45km/h
Current Limit	20A
Speed Sensor	01
Assistant Num	12
Assistant Sensitivity	3
Slow Start	-1-
Throttle-6km	OFF
Throttle-PAS	ON
Motor Mode	F/R

Speed sensor

Speed sensor is to set the magnet numbers on the wheel spoke for the speed sensor. Press ⊕ / ⊖ to choose from 01 to 12. press ① to confirm and save a changed set. The default setting is 01.

Advanced Settings	
Assist Levels	0-5
Wheel	20Inch
Speed Limit	45km/h
Current Limit	25A
Speed Sensor	01
Assistant Num	12
Assistant Sensitivity	3
Slow Start	-1-
Throttle-6km	OFF
Throttle-PAS	ON
Motor Mode	F/R

Speed sensor

Advanced Settings	
Assist Levels	0-5
Wheel	20Inch
Speed Limit	45km/h
Current Limit	25A
Speed Sensor	12
Assistant Num	12
Assistant Sensitivity	3
Slow Start	-1-
Throttle-6km	OFF
Throttle-PAS	ON
Motor Mode	F/R

Assistant Num

Assistant Num is to set the magnet numbers for the PAS sensor. Press ⊕ / ⊖ to choose from 04-09, 12, 24, 32. press ① to confirm and save the settings. The default is 12.

Advanced Settings	
Assist Levels	0-5
Wheel	20Inch
Speed Limit	45km/h
Current Limit	25A
Speed Sensor	01
Assistant Num	12
Assistant Sensitivity	3
Slow Start	-1-
Throttle-6km	OFF
Throttle-PAS	ON
Motor Mode	F/R

Assistant Num

Advanced Settings	
Assist Levels	0-5
Wheel	20Inch
Speed Limit	45km/h
Current Limit	25A
Speed Sensor	01
Assistant Num	04
Assistant Sensitivity	3
Slow Start	-1-
Throttle-6km	OFF
Throttle-PAS	ON
Motor Mode	F/R

Assistant Sensitivity

“**Assistant Sensitivity**” ,press ⊕ / ⊖ to change the values for assistant sensitivity. the settable range is 0-5. the default is 3. press ① to confirm a changed setting.

Advanced Settings	
Assist Levels	0-5
Wheel	20Inch
Speed Limit	45km/h
Current Limit	25A
Speed Sensor	01
Assistant Num	12
Assistant Sensitivity	3
Slow Start	-1-
Throttle-6km	OFF
Throttle-PAS	ON
Motor Mode	F/R

Assistant sensitivity

Advanced Settings	
Assist Levels	0-5
Wheel	20Inch
Speed Limit	45km/h
Current Limit	25A
Speed Sensor	01
Assistant Num	12
Assistant Sensitivity	5
Slow Start	-1-
Throttle-6km	OFF
Throttle-PAS	ON
Motor Mode	F/R

Slowly start

“**Slowly start up**” ,When pressing the pedal, it takes some time before receiving assistance. Select the desired value by pressing the “ ⊕ ” or “ ⊖ ” button, '4' is the slowest, and display defaults to '1' for slow start.

Advanced Settings	
Assist Levels	0-5
Wheel	20Inch
Speed Limit	45km/h
Current Limit	25A
Speed Sensor	01
Assistant Num	12
Assistant Sensitivity	3
Slow Start	-1-
Throttle-6km	OFF
Throttle-PAS	ON
Motor Mode	F/R

Slow start

Advanced Settings	
Assist Levels	0-5
Wheel	20Inch
Speed Limit	45km/h
Current Limit	25A
Speed Sensor	01
Assistant Num	12
Assistant Sensitivity	3
Slow Start	4
Throttle-6km	OFF
Throttle-PAS	ON
Motor Mode	F/R

Motor mode

"Motor Mode" is for setting the motor drive modes. Press ⊕ / ⊖ to choose from "F/R(dual drive), F(front drive), R(rear drive)", the default is "F/R (dual drive)".



Motor Mode



Bluetooth Connection Success Interface

Adjust the PAS Level

After the Bluetooth connection is successful, you can use the "+" and "-" functions in the Key-Disp APP to increase or decrease the PAS level of the e-bike to change the output power of the motor. PAS level 0 means no power assist output.

BLUETOOTH FUNCTION

APP Bluetooth Device

Open the Key-Disp APP and enter the APP homepage, click "My-More Devices-APP Device" to search for Bluetooth to add the display, click "Searched Bluetooth DevicesFinish", the display will show the symbol, which means the connection is successful.

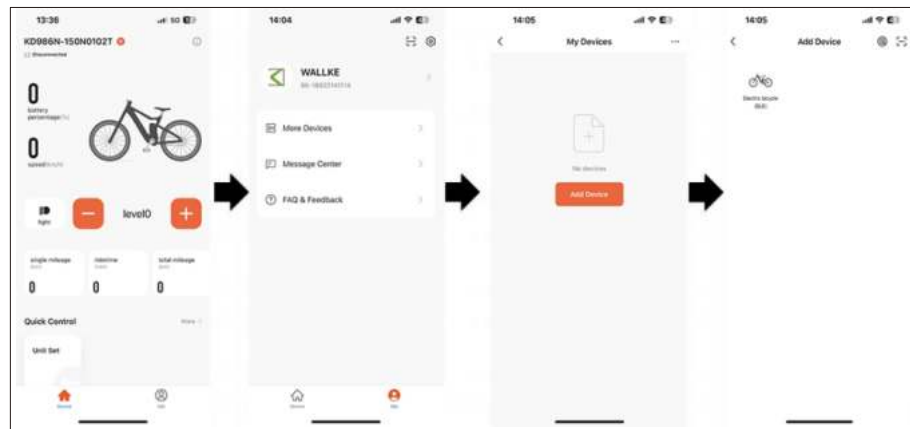

The Bluetooth device is added successfully Interface

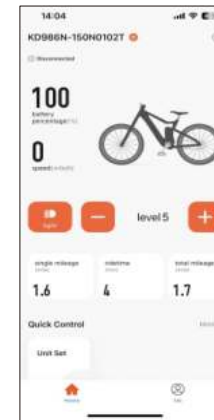

Adjust the PAS Level by APP

Turn on the Headlight

After the Bluetooth connection is successful, you can turn on the headlights through the "Headlights" function of the Key-Disp APP. After turning on the headlights, the brightness of the backlight will decrease. Click "Headlights" again to turn off the headlights, and the brightness of the backlight will return to the original brightness.

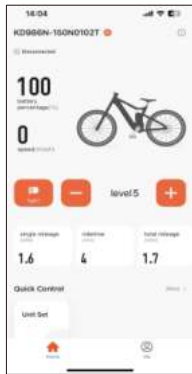

Turn on the headlight by APP

Multi-system switching

After the Bluetooth connection is successful, multiple Bluetooth systems can be switched through the Key-Disp APP.

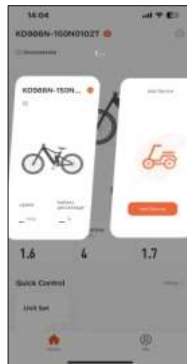

Multi-system switching Interface

KEY-DISP APP GUIDE

Downloads

Download from apple store/google store by key words "Key-Disp" . App logo is as follows:



Sign Up and Log In

In order to use all functions of Key-Disp app, users should sign up first. Please fill in the required information according to pictures below, click "Get Verification Code" and request to enter the verification code. Check the code in your email account used for the register process and enter the correct code. Then you can log in.

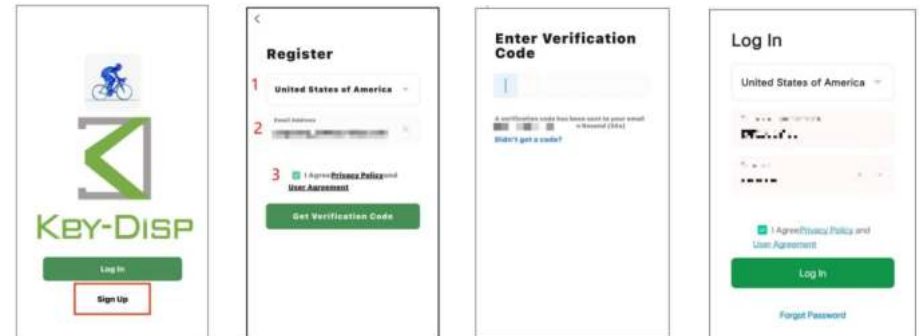

App connection

App must communicate with the ebike system to realize all its functions. When display is on, Add Device -> Add -> + > Done

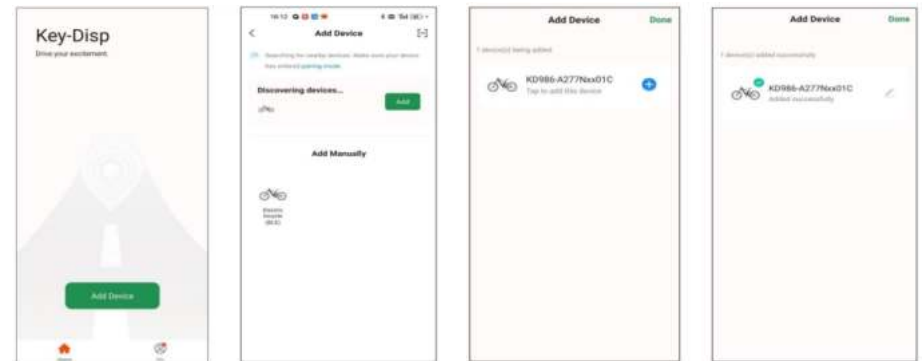

App operations & indication info

Bluetooth connection icon, battery power, speed, trip distance, riding time and ODO. The app can be operated to control the headlight status of the whole bike and switch the assist levels on the display.

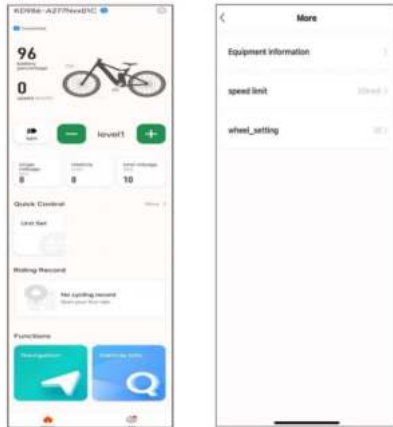

Fast operations

Fast operations: unit set (metric vs imperial), speed limit set, wheel size set.

- ◆ **Remarks:** if display complies with new EN standard, wheel size and speed limit are not settable on either display side or app side.

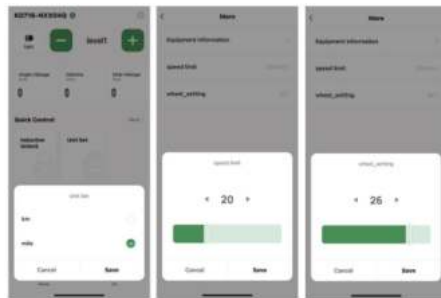

- Map navigation, Vehicle check-up.



- Riding record: if single trip distance is > 0.1km, the riding record will be saved.

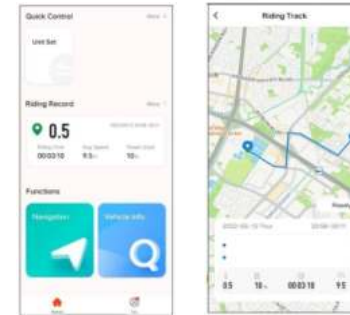

- Help and guide: click the icon to view FAQ and feedback.

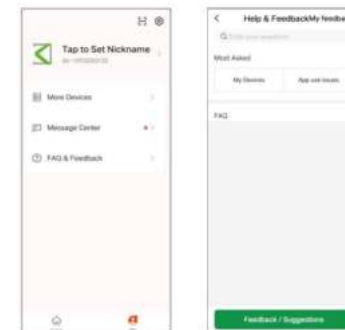

- Bluetooth connection and remove:

- ◆ After Bluetooth display has been paired with APP for the first time, it will automatically connect to the app.

Note: mobile network must be turned on for Bluetooth connection.

- ◆ Remove the Bluetooth display.

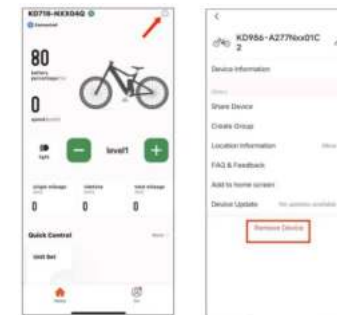

- Solution for: app unable to search Bluetooth device:

- ◆ When the device is powered on, press and hold the "i" and "-" for 2S at the same time, or make the display reset to factory settings.

How to use FIND MY

- Activation:
 - ◆ Press and hold the "+" button for more than 3s, then release it. Activate display function.
- Connection:
 - ◆ Open "Find My" application from your iPhone. Click the "Add Item" -- "Other Supported Item" -- "Connection" -- Name your display -- Choose an Emoji to represent your display -- Agree the display link to your Apple ID. Then you can find the display in your iPhone.



- Remove the Device:
 - ◆ Find your device from "Find My". Slide to the bottom of the screen. Click the "Remove Item" -- "Remove" -- "Remove".

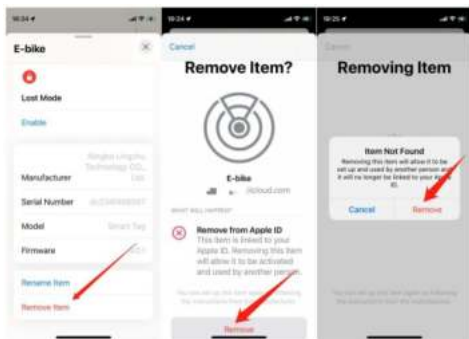

Re-power your display, After powering on for more than 40 seconds. Press and hold "+" for 15s and then release it to finish unbinding. Then use "Find My" again to search and verify if the unbinding is successful.

CARE & MAINTENANCE FOR YOUR NEW E-BIKE

You should in general, take care of your e-bike the way you would with a regular bicycle by keeping it dry, clean and the moving parts well lubricated. You should also avoid parking your e-bike in exposed areas whenever possible.

● For Your E-Bike, You Should Also Take Note Of The Following:

- ◆ Your e-bike is designed for regular country road use for a single person. Using your e-bike for extreme maneuvers, such as extreme off-road use, jumping, or carrying the excessive load will damage the e-bike and could cause serious injury.
- ◆ Do not use high-pressure water streams to clean your e-bike, as water might seep inside the motor or the wiring compartment and cause rusting of electrical parts or short circuits.
- ◆ Avoid parking your e-bike outside when there is rain or snow. At the end of a trip where there was rain or snow, bring the e-bike inside and use a clean, dry towel to eliminate any wetness.

● Battery Maintenance

- ◆ Use only the supplied charger to charge your battery. Do not use an unauthorized substitute. If your charger is lost or damaged, contact us to order a replacement.
- ◆ Do not open or alter the battery or the battery charger.
- ◆ Do not place the battery near fire or corrosive substances. Do not immerse in water or other liquids.
- ◆ Avoid subjecting the battery from high temperatures, such as directly under the hot sun, for prolonged periods of time.
- ◆ Do not connect (short circuit) the two poles of the battery.
- ◆ After much use, your battery's charge holding capacity will decrease. If you find that your battery does not hold sufficient charge even for short trips, you should contact us to order a replacement. Under normal use, the battery will undergo 1000 charging and discharging cycles.
- ◆ If the battery will not be used for an extended period of time, charge it fully and recharge it every 1 months. Store it in a cool place.
- ◆ Your e-bike battery is engineered with precision for high capacity and long useful life. We do not recommend that you use it to power other electrical devices. Improper use of the battery will damage the battery and shorten its useful life and may cause a fire or an explosion.

● Motor Maintenance

- ◆ Please check your motor frequently and tighten any loose screws or nuts, to prevent the vehicle from breaking down due to disconnected wires.
- ◆ The brushless motors are not waterproof, so avoid riding through water deeper than the lower edge of the electric wheel hub to avoid motor failure.

● Brake Maintenance

- ◆ Simply check the alignment of the pads with the disc, and check that the wheel is fully pushed back. Good alignment ensures the absence of noise and a normal wear of the pads.
- ◆ Regularly check the condition of your cables, ducts or harness and the wear of your pads.

Derailleur Maintenance

If shifting operation becomes less smooth. Clean the front derailleur and lubricate the link sections shown in the illustration. If gear shifting operations cannot be carried out smoothly. Clean the derailleur and lubricate all moving parts. If the amount of looseness in the links are so great, you should replace a derailleur.

Transmission System Maintenance

The most effective way is to add lubricant. We should remind everyone that the chain should always be kept oily and sensitive, especially after wading and raining. The active parts of the front and rear derailleur must also be frequently filled with oil. The oil used for the chain and the derailleur should preferably be a rust-proof lubricant designed for bicycles. Ordinary engine oil can also be used, but the effect will be poor. If the chain is rusty, you can first wipe the rust spots with a kitchen cleaner, then clean the chain, and then wash it in diesel to restore the mountain bike chain as before.

Lubricity

When you feel the chain is a bit stuck. In order to give you a better riding experience, lubricate the chain such that there's little noise. Keep the chain at work so that it can be smooth and unimpeded to ensure the operation of the bike. Intervals between maintenance depend on the use and riding circumstances.

Handlebar

Before riding, please make sure that the handlebar is correctly installed in accordance with the video installation steps. Regularly check whether the handlebar firmware is stable. If there is any looseness, temporarily stop riding and install the installation steps to check and reinstall.

Always check the condition of your bike before you ride in addition to having regular maintenance performed. If you are unsure of how to conduct a complete check of the condition of your bike before every ride, you should consult a certified, reputable bike mechanic for assistance.

● Before And After Each Ride

- ◆ Check the alignment of the wheels.
- ◆ Check the state of charge of the battery.
- ◆ Check that brakes function properly.
- ◆ Check tires for any punctures.
- ◆ Store the bike carefully in a clean and dry place.
- ◆ Check that your kickstand is tightly secured.
- ◆ Check for loose cables or wires that may be strained when turning the front wheel from left to right.

● For The Battery, You Should Also Take Note Of The Following:

Every 1 to 2 months, it is recommended that you check the following:

- ◆ Check that the handlebar and saddle post are correctly inserted and tightened.
- ◆ Check that the wheel hub mounting nuts are correctly tightened.
- ◆ Check that the wheel rims are not cracked and that no spokes are loose or broken.
- ◆ Check that the tires are not worn or cut.
- ◆ Check that the tires are correctly inflated.
- ◆ Check that the battery contacts on the frame are not dirty or oxidized.
- ◆ Check that the batteries are sufficiently charged.
- ◆ Check that the front and rear brakes are working correctly.
- ◆ Check that the cables are sufficiently greased, and that the brake pads are in good condition.
- ◆ Check that the frame welds are in good condition, and are free of corrosion or oxidation.

● Quarterly (Or About Every 750-1500 Miles)

- ◆ Check all items on the Monthly service list above.
- ◆ Check tire tread for excessive wear. Replace if necessary.
- ◆ Check that electrical connectors and cable housings are secured away from moving parts and are free from damage. Replace if necessary.
- ◆ Go into your local bike shop for a tune-up by a certified and reputable bike mechanic.

SAFETY TIPS

We Recommend The Following Safety-related Procedures:

- ◆ Wear a helmet.
- ◆ Ride in control at all times.
- ◆ Use lights and reflective gear in low light situations.
- ◆ Inspect your bike often — especially the brakes.
- ◆ Seek maintenance if there are any notable changes in bike performance.
- ◆ Know and observe the rules of the road before cycling. Bike users must follow all road rules.
- ◆ Ride defensively. To motorists, pedestrians, or even other cyclists, you are not as visible as you might think. Always watch for hazardous situations, and be ready to stop or take evasive action at all times. With the assistance of the electric motor, you may be travelling faster than drivers expect—beware of cars pulling out in front of you.
- ◆ Avoid road hazards. Watch for and avoid potholes, drain grates, railroad tracks, loose road material, and other hazards.
- ◆ Use both the front and the rear brakes together for best performance. Using **ONLY** the rear will significantly increase your stopping distance.

E-Bike Road Safety

Always obey traffic laws including lights, signals, and road signs that apply to traditional cyclists, cars, and other vehicles. Stay in the appropriate lane, using bike lanes when available. Cyclists tend to break the speed limit and red light laws.

This will only put you at risk of an accident. And this is a higher risk than for cyclists because your e-bike can travel faster than traditional bicycles. Do not cycle on the sidewalk/pavements as it can put both you and pedestrians at risk;

Be wary of everyone. E-Bike company AXcess states (source) that cars will not always realize how fast you are going and may assume that you are exponentially slower than them. To avoid the risk of accidents, always allow cars to get their right of way first, and do not rush. Be patient and alert, especially at intersections and turns.

Guide To Cycling At Night

Use Lights Properly: Riding bicycle at night require lights on both the front and rear of the bike.

For extra protection, wear a clip-on bike helmet light, or purchase a helmet with built-in LED lights. Light vests are easy-to-wear over clothing to allow drivers to see the cyclist from a greater distance and ensure that the vehicle will pass with enough clearance. Turn on any built-in lights setting out to ride.

BATTERY SAFETY

These safety precautions are provided for your benefit to protect you and those around you. Please read and follow them carefully to avoid unnecessary injury, damage to the product, or damage to other property.

Battery

CAUTION

■ Do not throw the battery into a fire. Do not overheat the battery.



■ Do not connect the battery to other appliances other than your battery.



Specified rechargeable battery

■ Use only the specified charger to charge the battery.



■ Do not take apart or modify the battery.



Disassembly Prohibited

■ Do not connect positive and negative terminals by using metallic objects.

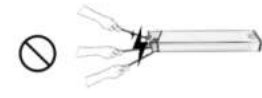

(Electrolyte leakage, overheating and/or rupture may result in this type of abuse.)

Battery Charger

CAUTION

■ Do not take apart or modify the charger



Disassembly Prohibited

■ Do not subject the charger to shocks, e.g. by dropping. Keep the charger away from water



■ Do not touch the charger with your skin for long periods during charging

Burning of the skin may result, as external temperature of the charger during charging may become 40C-60C(104F-140F)

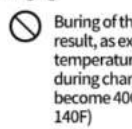

Overheating, fire or electric shock may result

■ Do not cover the charger or place objects on it

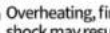

Overheating, fire or electric shock may result

■ Place the charger firmly on a flat dry surface

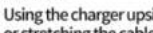

Using the charger upside-down or stretching the cable tight may result in malfunction, fire or electric shock

■ Do not short-circuit the terminals by using metallic objects

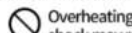

Overheating, fire or electric shock may result

⚠ WARNING

- Keep the battery away from water. Pouring water on the battery may result in short-circuit, overheating or permanent damage of the battery.
- Do not submerge the battery. Soaking the battery in water may cause irreparable damage.

⚠ WARNING

- Do not apply pressure to the cable or the plug.
- ⊘ Placing the cable tightened between a wall and a window frame, or placing heavy objects on the cord or the plug may result in electric shock or fire.
- Be sure to insert the plug securely into a wall socket.
- ⊘ Electric shock and overheating may result, causing fire.
- Do not touch the plug with wet hands.
- ⊘ Electric shock may result.
- Keep out of reach of children or pets.
- ⊘ Electric shock or injury may result.
- Do not attempt to use another maker or model's charger to charge the battery.
- ⊘ Overheating, fire or electric shock may result.
- Do not use the charging plug and/or the power source Plug when they are dirty, wet or dusty.
- ⊘ Insulation failure due to moisture absorbed in the dust may result, causing fire.
- Pull out the power source plug and clean it with a dry cloth.
- To remove a cable from a socket, pull the plug, not the cable.
- ⊘ Always pull the charging cable gently.
- Do not rotate the pedals when charging the battery while it is mounted on the bicycle.
- ⊘ The cord may twist around the pedal or the crank, and the damage to the plug may result, causing electric shock or fire.
- Do not apply voltage over the rated value to the charger.
- ⊘ Do not use sockets, correctors and other wiring devices with a power source other than standard rated voltage (AC110-240 volts) power supply.
 - Overheating, fire or electric shock may result.
- Do not use damaged components such as charge case, power cord, plug etc.
- ⊘ Electric short, short-circuit or fire may result.

Do not store the bike for more than 24 hours with an empty battery. This prevents a deep discharge with irreparable consequences from occurring.

Charge the battery and use the bike at least once every 30 days.

H9 AWD SPECIFICATIONS

Our bikes have a number of different traits, so it might not be possible to get every single attribute you want in the same model. Please find the specifications of our H9 AWD as listed below.

Battery	48V 40AH lithium battery / 60AH lithium battery
Motor	Features front 750 watt and rear 1000 watt Hub motors for a total of 1,750 watts
Maximum payload weight limit	350 lbs
Charging time	8-9 hours
Charger	US standard 48V 5A fast charger / 8A fast charger
Battery Charger Input Volt	110/220 volt AC
Battery Operational Temperature	0° to 40° Celsius (32° to 104° Fahrenheit)
Battery Life	Approximately 1000 complete charge/discharge cycles
Frame	20 inch aluminum alloy foldable frame
Display	Full-color LCD display (with USB port)
Freewheel	Shimano 7 speed
Fork	20-inch alloy hydraulic shock absorption, adjustable and locked suspension fork
Brake	Double-disc hydraulic brakes
Transmission	Shimano 7 speed
Seat	Silicone seat
Tire	20 x 4.0 inch fat tires for mountain, snow, rain or muddy road
Pedal Sensor	Cadence Sensor
Fender	Included
Rear Rack	Included
Front LED Light	Included
Taillight	Included

The brand of parts advertised on our product page may vary depending on the ongoing supply chain constraints in the eBike market. Component changes may occur without prior notification. All parts have been carefully inspected to ensure they equal the performance standard of the products advertised.

GENERAL TROUBLESHOOTING

As one or more causes of failure might lead to the failure phenomenon, you should find out the true cause(s) and then take the appropriate solution(s) to rectify the problem. In case of doubt, please consult a qualified technician for service, repairs or maintenance.

Phenomena	Possible Causes	Solutions
It doesn't work	<ol style="list-style-type: none"> 1. Insufficient battery power 2. Faulty connections 3. Battery not fully seated in tray 4. Brakes are applied 5. The bike will report a error code 	<ol style="list-style-type: none"> 1. Charge the battery 2. Clean and repair display connectors 3. Install battery correctly 4. Disengage brakes
Irregular acceleration and/or reduced top speed	<ol style="list-style-type: none"> 1. Insufficient battery power 2. Loose or damaged throttle 	<ol style="list-style-type: none"> 1. Charge or replace battery 2. Replace throttle
When powered on, the motor does not respond	<ol style="list-style-type: none"> 1. Loose wiring 2. Loose or damaged throttle 3. Loose or damaged motor plug wire 4. Damaged motor 5. The bike will report a error code 	<ol style="list-style-type: none"> 1. Repair or reconnect 2. Tighten or replace 3. Secure or replace 4. Repair or replace
Reduced range	<ol style="list-style-type: none"> 1. Low tire pressure 2. Low or faulty battery 3. Driving with too many hills, headwind, braking and/or excessive load 4. Battery discharged for long period of time without regular charges (aged or damaged) 5.Brakes rubbing 	<ol style="list-style-type: none"> 1. Adjust tire pressure 2. Check connections or charge battery 3. Assist with pedals or adjust route 4. Replace the battery 5. Adjust the brakes
The battery wont charge	<ol style="list-style-type: none"> 1. Charger not well connected 2. Charger damaged 3. Battery damaged 4. Wiring damaged 	<ol style="list-style-type: none"> 1. Adjust the connections 2. Repair or replace 3. Battery Voltage Testing
Wheel or motor makes strange noises	<ol style="list-style-type: none"> 1.Damaged motor bearings 2. Damaged wheel spokes or rim 3. Damaged motor wiring 4. Disc not centered 	<ol style="list-style-type: none"> 1. Replace 2. Repair or replace 3. Repair or replace motor 4. Adjust the brake or replacea
Sensor Issue	<ol style="list-style-type: none"> 1. Sensor loose 2. Sensor or cable broken damaged 	<ol style="list-style-type: none"> 1. Adjust the connections 2. Repair or Replace
Pre-load and turn off bike suddenly	<ol style="list-style-type: none"> 1. Battery or motor over heat protection 2. Battery or controller cable loose 3. Battery or controller cable damaged 	<ol style="list-style-type: none"> 1. wait 1-3 minutes to restart e-bike 2. Adjust the connections 3. Repair or Replace

ERROR CODES & TROUBLESHOOTING

In the event of a problem with the electrical components of your bike, the display will show an error code.

Compare the code with this list below and HOW TO RESOLVE:

CODE	ERROR	HOW TO RESOLVE
E001	Controller failure	The controller connection might be disconnected or damaged. Make sure it is free from grit or contaminants and is firmly connected. Service or replace the controller.
E004	Throttle Error	When you press and release the throttle, it should return to the original position. Remove any obstructions. Check the throttle and throttle cable for damage, such as a cut or frayed cable.
E006	Motor Phase Error	Check the cable that connects the rear hub motor to the rest of the system and make sure it is free from grit or contaminants and is firmly connected. This error might appear if you don't reconnect the cable after removing the rear wheel (for example, after changing a flat tire, or transporting your bike in the trunk of a car). At least one of the motor phase wires has been damaged or is temporarily disconnected.
E003	Hall failure	The hall sensor inside the rear hub might be disconnected or damaged. Service or replace the rear hub.
E005	Brake Error	When you apply the brakes - built in "magnetic reed switches" disengage the motor's power when the lever is squeezed. If the lever is damaged (for example, following a crash), it might need to be replaced.
E002	Communication failure	Poor connection between the controller and the display, check all cable connections.

Wallke E-Bike Warranty

Every Wallke E-bike is covered under our manufacturer's one year all-inclusive warranty for the original owner against all manufacturing defects.

Note: The warranty applies only to original owners and is not transferable.

What About Warranty On Wallke?

Parts covered by the warranty: frame, forks, stem, handlebars, headset, seat post, saddle, brakes (excluding brake pads), lights, bottom bracket, crank set, pedals, rims, wheel hub, freewheel, cassette, derailleur, shifter, motor, throttle, controller, wiring harness, LCD display (excluding damage due to water), kickstand, reflectors, and hardware. The battery warranty does not include damage from power surges, use an improper charger, improper maintenance or other such misuse, normal wear, or water damage.

The warranty does not cover an incorrect assembly or installation of the product by the user; an improper or negligent use, operation or transformation of the product; a maintenance contrary to the maintenance instructions of the product (eg. lack of maintenance of the brakes); normal wear and tear; defects inherent to the normal useful life or service life of the product, such as a flat battery that can be replaced by the consumer; damages or defects due to accidents.

Notes:

Failure caused by the following cases are not included in the warranty contents. However, the designated store or sales dealer has the responsibility and obligation to provide paid repair service:

- ◆ Without invoice and the warranty.
- ◆ Using and maintaining without complying with the user's manual.
- ◆ Using the electrical bicycle for other purposes or dangerous acts.
- ◆ Dismantling the parts without permission or improper use and storage.
- ◆ Without using the original parts.
- ◆ Traffic accidents or other accidents.
- ◆ Anti-rust layer damage caused by abnormal use, which leads to the corrosion and fracture of the parts.
- ◆ Riding on the abnormal road conditions.
- ◆ Commercial rental use.
- ◆ Irresistible natural disasters.

Shipping Damage Claims

IMMEDIATELY inspect your product(s) for damage. Shipping damage must be reported to Wallke Ebikes within 7 days of shipment arrival. We will not accept Shipping Damage Claims later than 7 days from receipt of products.

What Will We Do To Correct Problems With Your Bike?

If any component is deemed to be defective or damaged without user error, we will issue a replacement part and assist you in replacing the defective parts. We will replace any parts deemed to have been damaged during shipping.

Contact Us

If your question has to do with your order, please include your order number and eBike serial numbers.

eBike serial numbers: Each bike has a serial number stamped on the bottom axis connecting the left crank arm.

Order ID: You can find this in the order history of the account the purchase was made through.

Please contact our service department at the below email. Please attach any relevant videos or photos showing your issue so the specialists can best assist you.

Please attention that Wallke electric bike has several sales channels now. Each sales channel has its order list and covers its own after service, including the warranty service, return service, and all.

Choose the right one to get connected! Or could not get the answers! If you've already submitted an inquiry, be assured that we are working diligently to respond (within 24 hours).

 **Wallke Ebike Website:** www.wallkeebike.com

 **Website Service Email:** sales@wallkeebike.com

 **Amazon Service Email:** info@wallkeebike.com

 **Phone:** 1-323-841-3459

- ◆ **Note:** If for some reason you didn't receive our reply email within 48 hours, please kindly check your spam folder.