



## Jarvis WLFT Series • Large Forward Throw Wall Pack

Durable and efficient LED wall pack lighting saves electricity, reduces maintenance and enhances night-time visibility.

**LEDs:** WLFT Series features high-efficiency LEDs. Fewer diodes are needed to create equal or more light.

**Optics:** WLFT Series features patent-pending optics that control light spread. Over 90% of the light is directed downward and outward, improving the distance this light illuminates. The optics are enclosed by a prismatic glass lens.

**Housing:** Die-cast aluminum construction provides durability. Bronze powder-coat finish is standard.

**Mounting:** Standard style wall-pack housing makes mounting simple. Conduit can enter from all sides and/or back of fixture. Design allows for back mounting plate to be mounted separately from LED components, making for “hands free” wiring.

**Dimming:** WLFT Series is compatible with 0-10V dimming controls.

**Photo-cells and Motion Sensors:** WLFT series is compatible with many photocells and motion sensors. Consult Jarvis Corp for more information.

**Certifications:** ETL Listed. Conforms to required UL 1598. Suitable for wet locations. WLFT-400 is on the DesignLights Consortium™ Qualified Products List.

**California Title 24:** Meets Title 24 requirements when installed with controls. Contact Jarvis Corp for more information.

**Rebates:** The WLFT Series qualifies for many government and utility rebates.

### Electrical and Light Output Specifications

Model Number	WLFT-400
High Efficiency Diodes	4 LEDs
Input Power	105W
Lumens	11,110
Typical Metal Halide Replacement	400W
Electrical Input	120-277V, 50-60HZ Power supply automatically adjusts to line voltage within range
Dimming	0-10V Dimming Compatible
Color Temperature	5000K
Color Accuracy (CRI)	> 70
Power Factor	> .95
Lifetime	75,000-100,000 hours
Warranty	5 years

### Mounting and Spacing

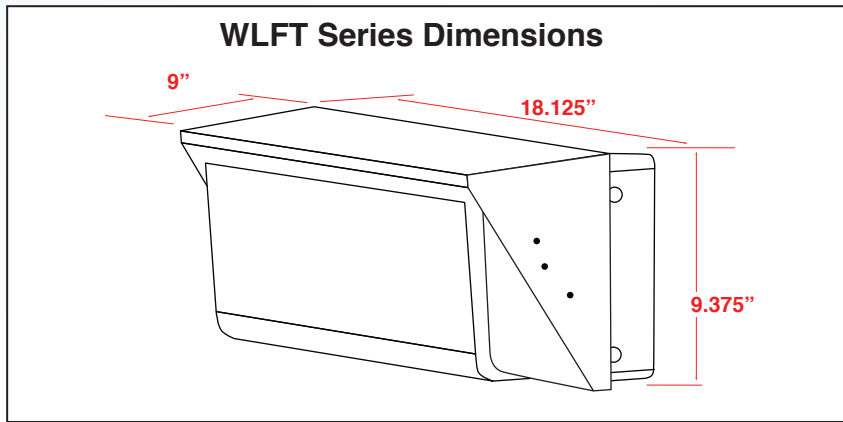

**Mounting Heights and Spacing:** WLFT Series perform best with spacing of 2-4 times the mounting height.



Jarvis Corp  
1950 Estes Ave  
Elk Grove Village, IL 60007  
(800) 363-1075



ARRA Funding  Compliant Assembled in the US of US and Imported Parts