









# Bold MFG Charger Mount for Milwaukee M12™ Installation Instructions

## Included Components and Hardware

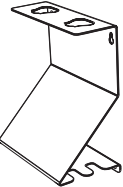
- (A)  Qty 4, #8 x 1" Self Tapping Screw
- (B)  Qty 1, #8 x 1/2" Self Tapping Pan Head Screw
- (C)  Qty 2, #8 x 1/2" Self Tapping Flat Head Screw
- (D)  Qty 4, Drywall Anchor
- (E)  Qty 1, Charger Mount
- (F)  Qty 1, Charger Locking Tab

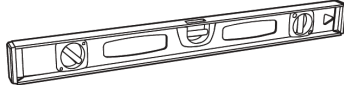
## Tools Needed for Installation

-  Level
-  Cordless Drill
-  3/16" Drill Bit

## Compatibility

This charger mount is designed to work only with Genuine Milwaukee M12™ products. We do not guarantee the fitment of aftermarket/ off brand chargers and batteries  
 Compatible Chargers : M12™ Charger, M18™ & M12™ Multi-Voltage Charger,  
 Compatible Batteries : M12™ Redlithium™ Batteries

## Step 1 – Install the Mount to Wall

Determine the best location for your Bold MFG Charger Mount (D). Remember to locate it near an outlet to for easy access to your charger. Using a level, hold the charger mount up to your wall and mark the upper two installation holes. If you are mounting this to drywall, pre-drill with a 3/16" bit for drywall anchors (D), then tap the anchors in flush. Install the qty 2, #8 x 1 Screws (A) into the anchors or directly into wood and leave them about 1/8" off the wall. Hang the charger through the keyslot holes and then mark the final lower two holes. Finish the installation using the same hardware, (A, D). Fully tighten all the screws to secure the mount to the wall.

## Step 2 – Mounting the Charger FIG.1

The mount has five holes in the sheetmetal face for the supplied mounting screws to secure the Milwaukee Charger and metal locking tab.  
 Measure the key slot spacing on the back of your charger to determine which holes to use. Our mount accomidates 3.00" and 4.00" O.C. spacing. See Fig 1.  
 Using the supplied qty 2, #8 x 1/2" (C) Screws install them directly into the metal using a drill or impact driver. These are self tapping screws and will form threads as you install the screws. Leave them about an 1/8" off the surface. Install the charger over the two screws and slide the charger down to lock it in. If the charger will not slide down the screws, the height of the screws

## Step 3 – Install the Locking Tab

The Locking Tab (F) will securely hold the charger to the mount. The locking tab is installed with one #8x1/2" Screw, B. Position the tab as shown in Fig. 1. It helps to installed this screw with an extension on your impact driver. The tab is slotted to allow it to be slid tight against the charger. Tighten the screw to snug the tab against the charger.

## Step 4 – Get Organized

Used the slotted cord wrap located at the bottom of the charger mount, wrap the excess cord from the charger and plug it in to the nearest recepticle. Enjoy your new charging experience! Don't forget to tag @boldmfg and show off your newly organized workspace.

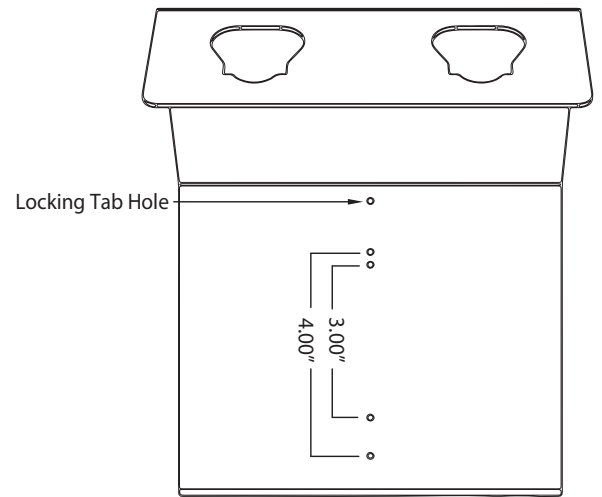

FIG. 1

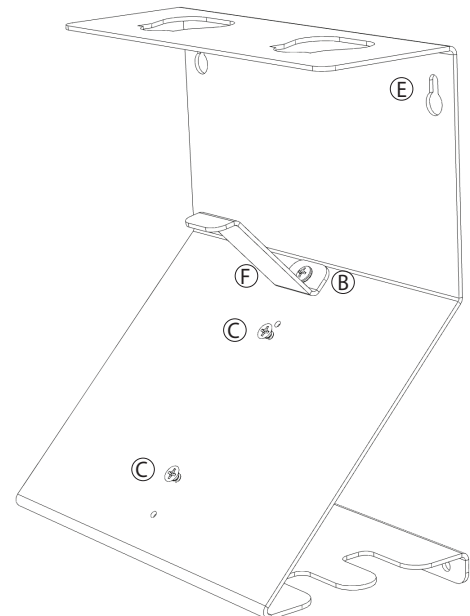

FIG. 2