

5040CTEFH25 5050CUEFH25, & 5050CTEFH25 High Head Effluent Pumps

This high quality and dependable pump features a stainless steel housing and a cast iron base. With a built-in thermal overload protection for safety and a permanent split capacitor continuous duty motor. Convenient carrying handle is attached.

Features:

- Non-clogging stainless steel vortex impeller
- Also available without a switch
- 2" or 1 1/2" FNPT with adapter - discharge size
- Tethered float switch
- Handles 3/4" solids



See Pumps & Accessories
Price List for Limited Warranty details.

Performance Curve

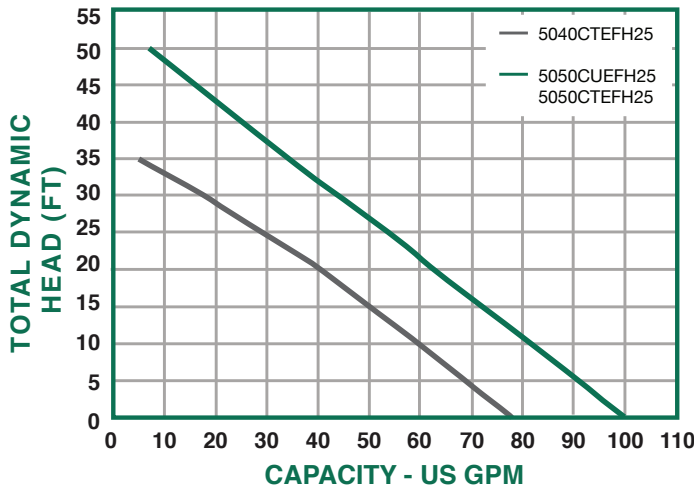

Dimensions

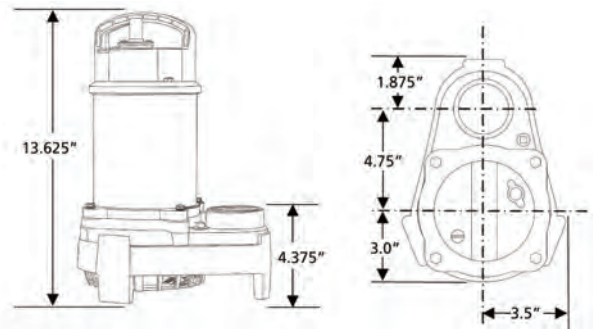

Performance

Model	Gallons per Minute in Feet										
	0	5	10	15	20	25	30	35	40	45	50
5040CTEFH25	78	69	60	50	41	29	18	5	-	-	-
5050CUEFH25 5050CTEFH25	100	91	82	72	63	54	44	34	25	16	7

Specifications

Model No.	HP	Volts	Hz	Amps	Construction	Discharge Size	Cord Length	Solids Handling	Switch	Phase	Wt.
5040CTEFH25	4/10	120	60	7.5	Cast Iron / Stainless Steel	2" or 1 1/2"	25'	3/4"	Tethered	1	27
5050CUEFH25 (NO SWITCH)	1/2	120	60	12	Cast Iron / Stainless Steel	2" or 1 1/2"	25'	3/4"	N/A	1	26
5050CTEFH25	1/2	120	60	12	Cast Iron / Stainless Steel	2" or 1 1/2"	25'	3/4"	Tethered	1	28