

VELANTOCOMFORT+

BACK TO WALL SUITE

CODE: VT1100

Just
BATHROOMWARE

gallaria

intelligentbathrooms®

- Inclusions
- ✓ VELANTOCOMFORT+ Back to Wall Suite with Intelligent Bidet Seat
 - ✓ Waste pipes
 - ✓ Water filter
 - ✓ Check valve/ball valve & inlet hose

- Features
- Fully concealed water & electrical connections (hidden from view)
 - Heated seat
 - Instantly heated water 35°C-38°C
 - Self-cleaning shower spray nozzle with rear and woman's wash functions
 - Easy to use control knob to adjust and control wash
 - Adjustable flush volume
 - Aerated wash stream
 - Soft close seat
 - 5 Year warranty (2 years parts & labour)

Note

This intelligent toilet is fitted with an integrated high hazard backflow prevention device that meets the installation standards outlined in AS/NZS 3500.

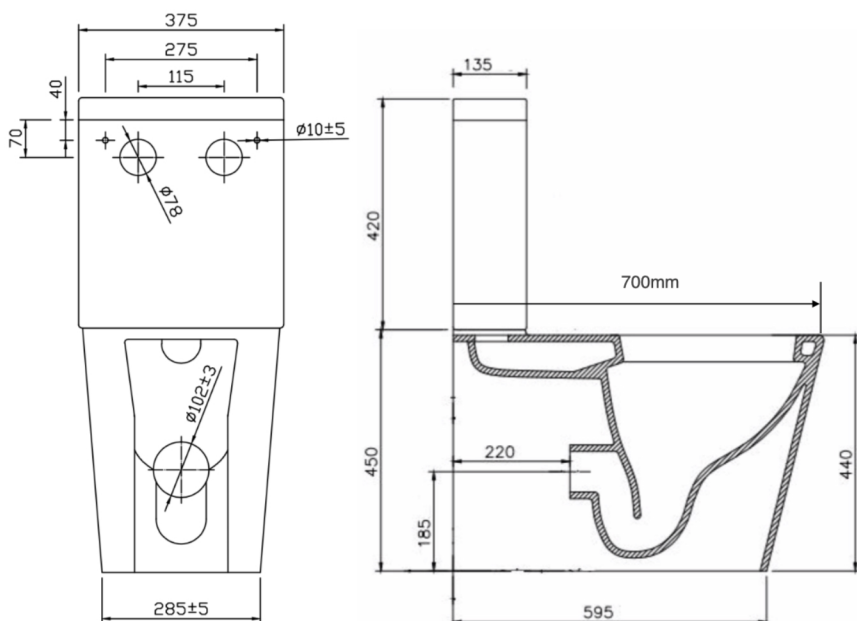

Notes for the installer

Connection to rain water or grey water is not recommended. It should only be operated with potable/drinking water.

Standard setout: 80-170mm

Other vario-bend setout options:

90-170mm - code: XLDFB09
170-240mm - code: XLDFBQP

The maximum water pressure for water supply is 500kpa.

Power supply requirements: Dedicated 10A min, 220~240V AC, 50/60Hz supply

The water filter has a service life of approximately 6 months.

WELS: 0016
WM: 030025

VELANTOCOMFORT+

BACK TO WALL SUITE

CODE: VT1100

Just
BATHROOMWARE

gallaria

intelligentbathrooms®

WATER & ELECTRICAL CONNECTION DETAILS

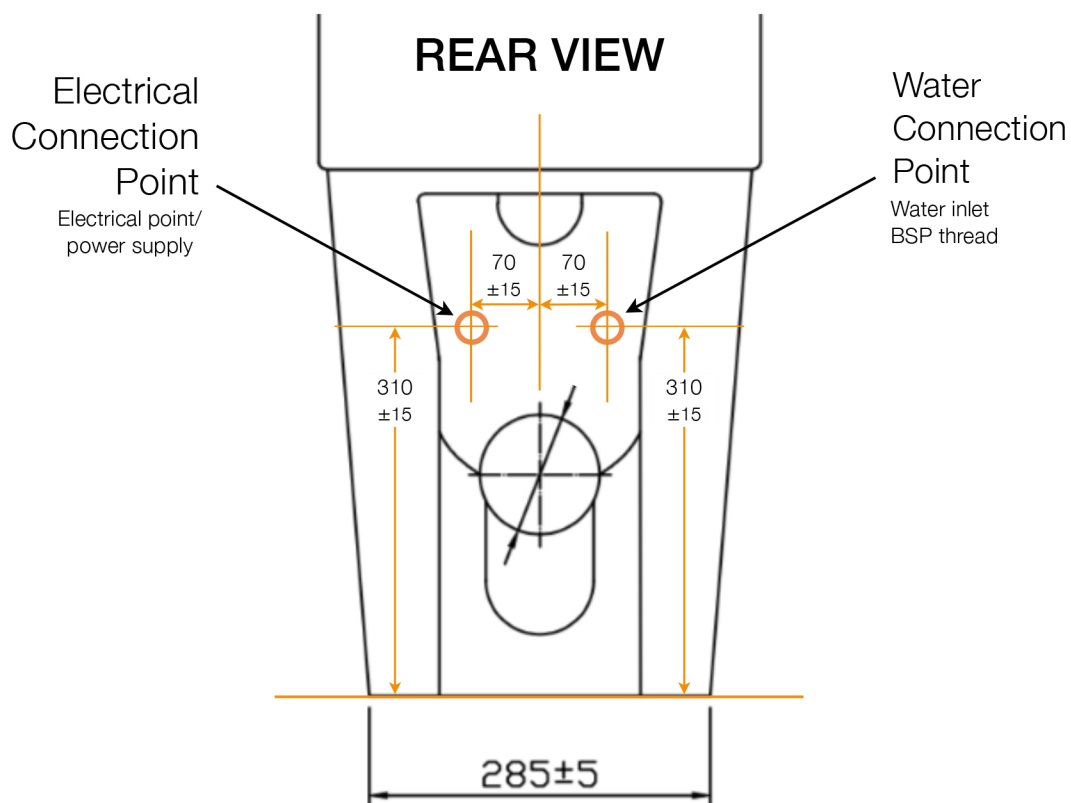

WELS: 0016
WM: 030025