

BLANCA 500

LED SHAVING CABINET

SPECIFICATIONS

WIDTH	500mm
HEIGHT	900mm
DEPTH	145mm
WEIGHT	18.25kg
ORIENTATION	Portrait

LIGHTING SPECIFICATIONS

CCT	6500K – daylight
CRI	>80

INSTALLATION

- Wall mount
- Hardwired
- Input voltage: 220-240v 50Hz
- Includes wall mount split batten
- Mounting holes are provided for semi-recessed mounting

FEATURES

- Copper Free Mirror
- LED Lighting (Adjustable Colour Temperature)
- Frontlit
- Touch Sensor
- Demister
- Soft Close
- Concealed Wire Technology
- Two Adjustable Glass Shelves
- Single-Sided Mirror Door (door opens right to left)
- Semi-recessable



Disclaimer: All LED Products requiring hardwiring must be installed by a licensed electrician in accordance with local regulations. Sizes are in mm and nominal and should be checked prior to installation. Actual colours may vary so please check colour samples before ordering. Installation is acceptance of our products. Installation of faulty, warped, chipped or damaged products will void our warranty.

FINISH

White

PRODUCT CODE

BR50D

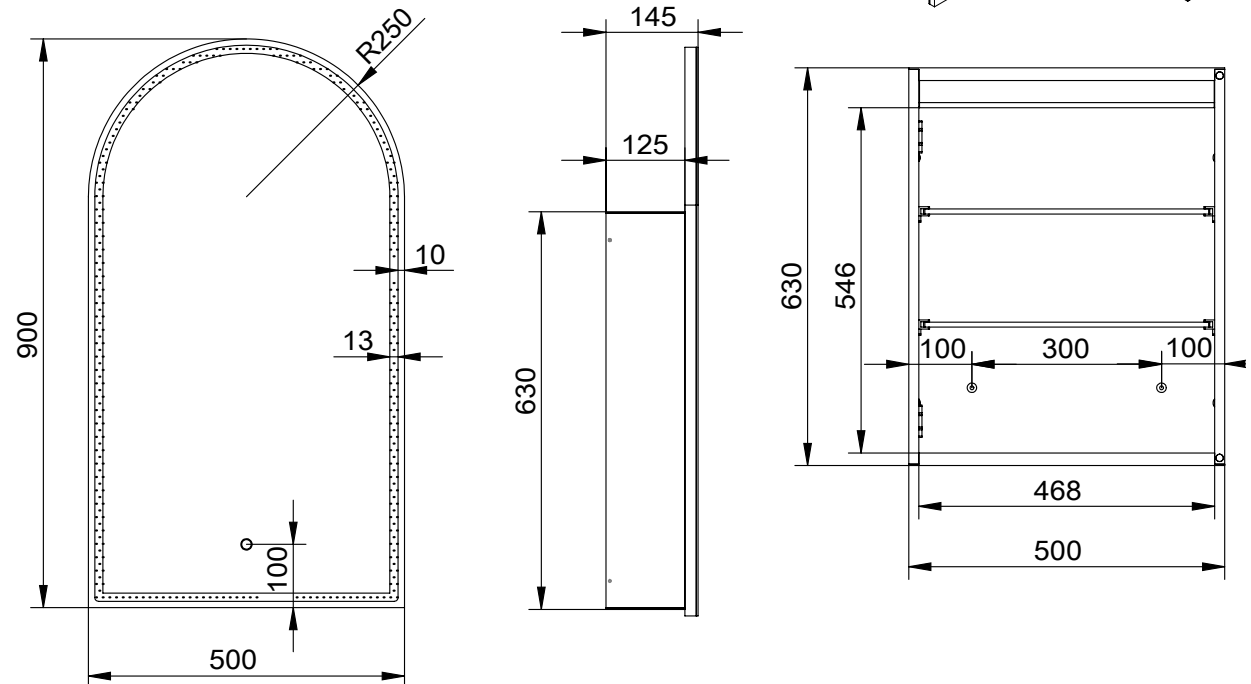
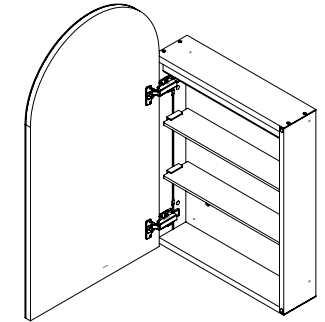

BLANCA 500

LED SHAVING CABINET WITH ALUMINIUM FRAME

SPECIFICATIONS

WIDTH	504mm
HEIGHT	904mm
DEPTH	150mm
WEIGHT	25kg
ORIENTATION	Portrait

LIGHTING SPECIFICATIONS

CCT	6500K – daylight
CRI	>80

INSTALLATION

Wall mount
Hardwired
Input voltage: 220-240v 50Hz
Includes wall mount split batten
Mounting holes are provided for semi-recessed mounting

FEATURES

Copper Free Mirror
LED Lighting (Adjustable Colour Temperature)
Frontlit
Touch Sensor
Demister
Soft Close
Concealed Wire Technology
Two Adjustable Glass Shelves
Single-Sided Mirror Door (door opens right to left)
Semi-recessable



Disclaimer: All LED Products requiring hardwiring must be installed by a licensed electrician in accordance with local regulations. Sizes are in mm and nominal and should be checked prior to installation. Actual colours may vary so please check colour samples before ordering. Installation is acceptance of our products. Installation of faulty, warped, chipped or damaged products will void our warranty.

FINISH		PRODUCT CODE
Brushed Brass		BR50D-BB
Brushed Nickel		BR50D-BN
Gun Metal		BR50D-GM
Matte Black		BR50D-MB
Matte White		BR50D-MW

