

Non-Standard Rods

For non-standard rod dimensions, or undersized rod end threads, put a “3” in model number and describe the rod using the letters shown in the drawing. Specify CC, LE and A dimensions.

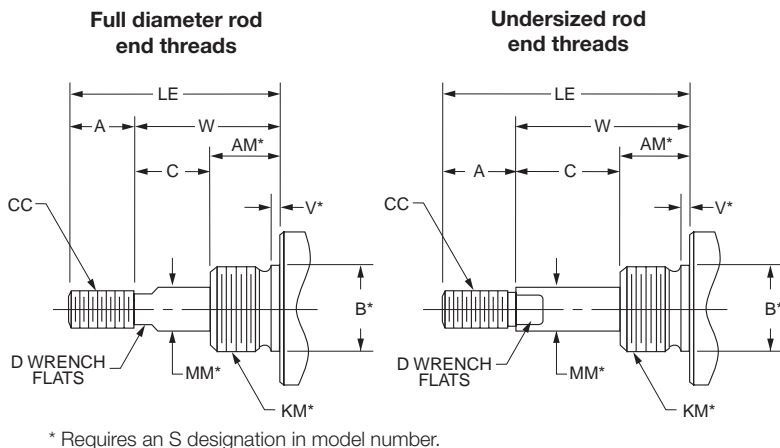

B

Round Body Cylinders
 Actuator Products

Mounting Style N

Nose Mount, Spring Return

Bore size	SR	SRM	Std. strokes (in)	Max.. stroke (in)	SS rod std
5/16"	•		1/2, 1, 1-1/2, 2, 2-1/2, 3, 4	4	✓
7/16"	•		1/2, 1, 1-1/2, 2, 2-1/2, 3, 4	6	✓
9/16"	•	•	1/2, 1, 1-1/2, 2, 3, 4	6	✓
3/4"	•	•	1/2, 1, 1-1/2, 2, 3, 4	6	✓
7/8"	•		1/2, 1, 1-1/2, 2, 3, 4	6	✓
1-1/16"	•	•	1/2, 1, 1-1/2, 2, 3, 4	6	✓
1-1/4"	•	•	1/2, 1, 2, 3, 4	6	✓
1-1/2"	•	•	1/2, 1, 2, 3, 4	6	✓
1-3/4"	•	•	1/2, 1, 1-1/2, 2, 2-1/2, 3, 4	6	
2"	•	•	–	4	

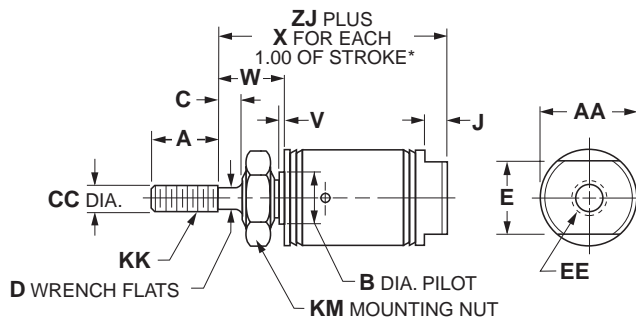

Bore size	ZJ															
	A	AA	B	C	CC	D	E	EE	J	KK	KM	V	W	X	SR	SRM
5/16"	0.38	0.36	–	–	0.125	–	0.36	#10-32	–	#5-40 UNC	1/4-28	0	0.25	0.75**	1.12	–
7/16"	0.50	0.50	0.374	–	0.188	–	0.38	#10-32	0.19	#10-32 UNF	3/8-24	0.05	0.31	0.94**	1.31	–
9/16"	0.50	0.62	0.437	–	0.188	–	0.50	#10-32	0.19	#10-32 UNF	7/16-20	0.06	0.38	1.62	1.53	1.76
3/4"	0.50	0.81	0.499	–	0.250	–	0.62	1/8 NPTF	0.19	1/4-28 UNF	1/2-20	0.09	0.44	1.69	1.50	1.75
7/8"	0.50	0.93	0.624	–	0.250	–	0.62	1/8 NPTF	0.19	1/4-28 UNF	5/8-18	0.09	0.50	1.56	1.84	–
1-1/16"	0.50	1.12	0.624	0.12	0.312	0.25	0.88	1/8 NPTF	0.19	5/16-24 UNF	5/8-18	0.09	0.62	1.56	2.06	2.31
1-1/4"	0.75	1.34	0.749	0.25	0.437	0.38	0.88	1/8 NPTF	0.25	7/16-20 UNF	3/4-16	0.09	0.88	1.81	2.66	2.78
1-1/2"	0.75	1.56	0.749	0.25	0.437	0.38	0.88	1/8 NPTF	0.25	7/16-20 UNF	3/4-16	0.09	0.88	1.69	2.44	2.69
1-3/4"	0.88	1.84	1.031	0.38	0.500	7/16	1.25	1/4 NPTF	0.25	1/2-20 UNF	1-14	0.09	0.75	2.0	2.97	3.09
2"	0.88	2.08	1.374	0.38	0.625	0.50	1.25	1/4 NPTF	0.31	1/2-20 UNF	1-1/4-120.12	1.19	–	▲	▲	

▲ 5.66" for 1" stroke; 7.66" for 2" stroke; 8.91" for 3" stroke; 11.84" for 4" stroke.

* To determine lengths for half inch stroke increments, determine length for next highest whole number stroke and subtract a half inch.

** For each 0.50" of stroke

