



High Resolution/High Speed Registration Mark Sensor

MARK-EYE® PRO

MARK-EYE® PRO

High Resolution/High Speed Registration Mark Sensor

The **Mark-Eye® PRO** registration mark sensor was designed to detect printed registration marks on a continuous web. Optimized for high-speed color detection, seeing registration marks on form-fill-seal machinery has never been easier.

The **Mark-Eye® PRO** sensor was designed to deliver high-resolution performance by utilizing the broadband characteristics of a white light LED for detecting the greatest variety of color combinations on any color background. The “one-touch” AUTOSSET routine can be accomplished by pushing the appropriate button on the sensor or from a remote push-button switch.

The **Mark-Eye® PRO** sensor was designed for both the apertured V-axis (V4A) lens or fiberoptic light guides. We recommend using glass fiberoptic light guides for detecting low contrast registration marks. Our NEW miniature glass fiberoptic light guides are excellent when you need a tight bend radius or for those hard-to-get-to locations.

Plastic light guides can also be used with this new sensor. A variety of fiberoptic accessory lenses can be used to enhance sensing performance. Setup could not be easier with the “One-Touch AUTOSSET. Simply put the background in view and press the black button if the background is darker than the registration mark or press the white button if the background is lighter than the registration mark.



Features

- White Light LED
- 175µs or 45µs models available
- Interchangeable optical blocks; Fiber Optic or V-axis lens.
- Pulse Stretch Timers; 10ms, 25ms, or 50ms selectable.
- One button push setup
- Outputs automatically configured for mark
- Remote AUTOSSET wire
- Button lock
- Cable or connector version

Benefits

- Highly accurate for precise detection of marks at high speeds
- High resolutions for a variety of colored marks on various colored backgrounds
- Timers to assist in overcoming inconsistent web materials, or false triggers
- Remote setup for hard to reach areas
- Flexibility in sensing applications reduces inventory costs and setup time

TRI-TRONICS MARK-EYE® PRO Series Sensors are easier to set up than conventional color mark sensors because of their unique built-in Contrast Indicator™. Examples of setup instructions for various materials are shown below.

Opaque or Transparent Web Material

1. Position the sensor or fiberoptic light guide to view material looking straight down (see Fig.1).
2. Place background in view of fiberoptic light guide.
3. Push button as follows...
 - A. For dark mark on light background, push and hold the white AUTASET button for about 1 second with background in view. The contrast indicator will illuminate from 1 to 5, flash, and then remain on 5.
 - B. For a light mark on a dark background, push and hold the black AUTASET button for about 1 second with background in view. The contrast indicator will illuminate from 5 to 1, flash, and then remain on 1.
4. Move mark into view to test the setup. The contrast indicator should move from 5 to 1 on a dark mark, and 1 to 5 on a light mark. If the contrast is less than a full swing, then you can use the buttons to manually adjust the sensor by tapping up or down to dial in the proper contrast. If the contrast is less than 5 bars of deviation, then move closer to the web.

Hints and Tips:

1. False tripping or erratic operation is usually caused by excessive web flutter, wrinkles, or variations in material background color or marks. Minor adjustments of the manual Up/Down adjustment can help to eliminate erratic operation.
2. A metal guide plate for the material to flow across provides several necessary advantages:
 - A. Helps to iron out wrinkles.
 - B. Helps to eliminate web flutter.
 - C. Provides shiny background when sensing marks on transparent material.
3. For foil or shiny material with black mark, you may need to angle sensor or fiber optic light guide slightly, 10 degrees or more.
4. For foil or shiny material with white mark, you may need to angle the sensor or fiber optic light guide by 30 degrees or more.

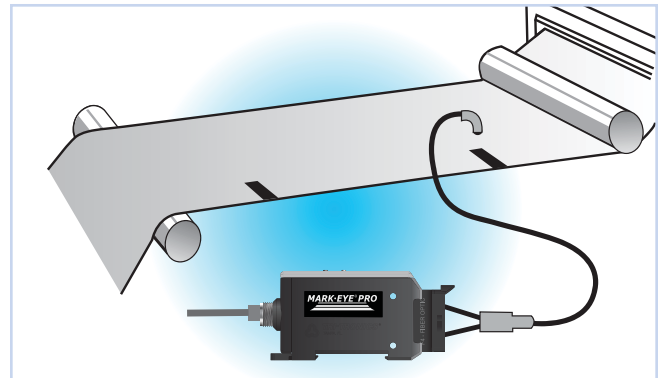
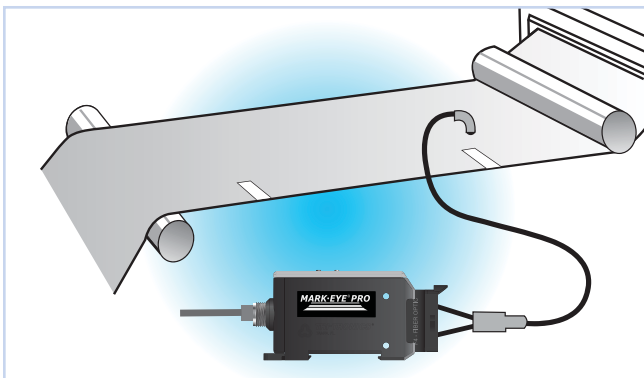

Fig. 1 Straight Position

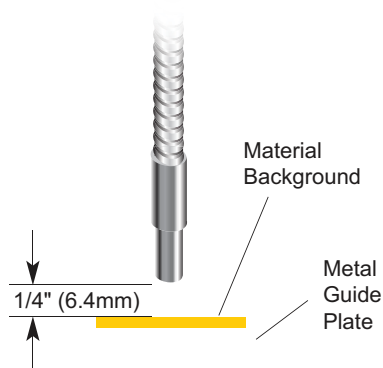
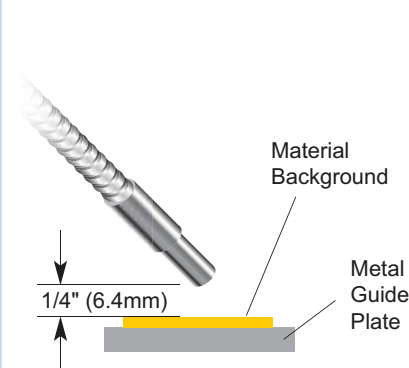

Fig. 2 45° Angle Position



Features

MARK-EYE® PRO

MARK-EYE® PRO

2

Registration Mark Photoelectric Sensors

AGS AUTOMATIC GAIN SELECT

This unique feature provides automatic digital selection of amplifier gain based upon your sensing requirements.

AUTOSET ADJUSTMENT

The AUTOSET adjustment routine only requires the push of one button, one time. Even in a dynamic operating condition, with ongoing input events, all that is required is to push the button for a perfect setting.

EDR®

Another unique feature is the digitally-controlled EDR (Enhanced Dynamic Range) circuit. It prevents dark state saturation and expands the operating range without reducing amplifier gain.

REMOTE AUTOSET

To remotely AUTOSET the sensor, apply a momentary contact closure from the AUTOSET input wire to negative as shown in the wiring diagram. A remote AUTOSET command will duplicate the last manual AUTOSET.

5 LED DUAL FUNCTION INDICATOR

Contrast Indicator – Provides “at-a-glance” performance data.

Status Indicator – Displays status of selectable features:

Lock – When this feature is enabled the sensor becomes tamperproof.

Note: The remote AUTOSET is not affected by the lock.

Output Invert – Allows the sensor to be programmed for the output transistors to be “ON” or “OFF” when the registration mark comes into view.

Timer – When the “OFF” delay pulse stretcher is enabled, the output duration is extended by 10, 25, or 50 milliseconds (not additive). Enabling the Timer allows ample time for the controller to respond. The time durations of the gap between marks must be less than the selected delay.

HIGH SPEED

45 or 175 microsecond response when detecting light or dark marks.

CONNECTIONS

Built-in 12 mm connector or 6' cable.

MOUNTING OPTIONS

Built-in DIN rail “Snap-On” design, through hole, or bracket mount.

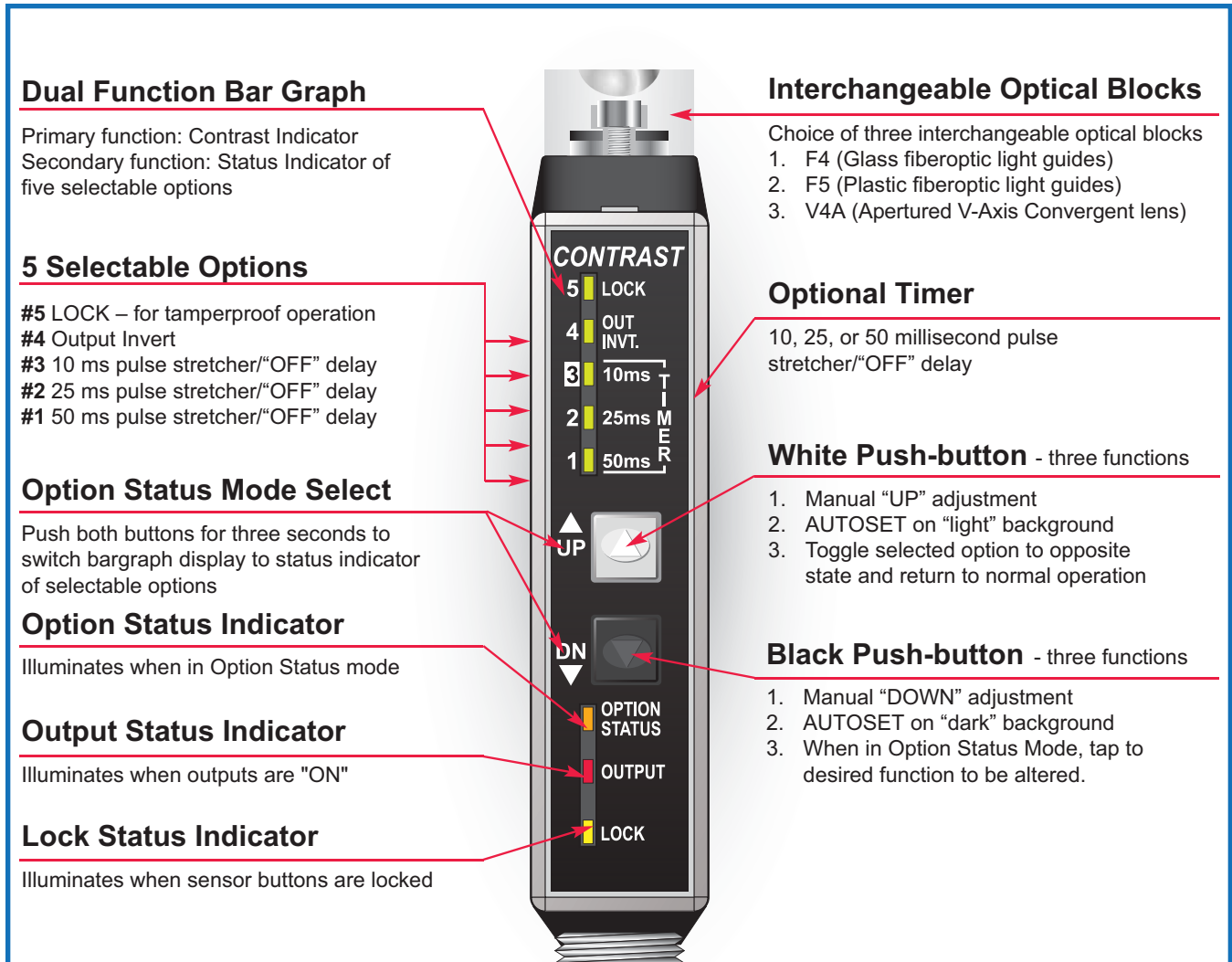

| Model | Description |
|------------------------------|--------------------------------|
| 5-Conductor, Cable Attached: | |
| MEP45WL | 45µs Response Time, White LED |
| MEPWL | 175µs Response Time, White LED |
| 5-Pin Micro Connector (M12): | |
| MEP45WLC | 45µs Response Time, White LED |
| MEPWLC | 175µs Response Time, White LED |

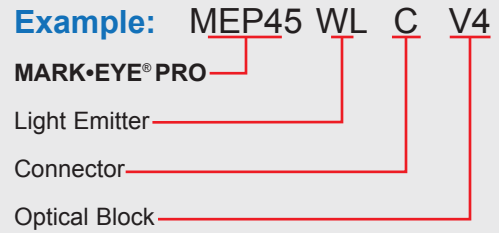

1. Sensor model: MEP45, MEP
2. White light source: WL
3. Select Connector
Blank = 6' (1.8m) Cable, C = Connector
4. Select Optical Block based on sensing mode:
F4 – Glass Fibers 0.25" (6.4mm) to 0.50" (12.7mm) range
V4A – Apertured V-Axis 0.75" (19.1mm) to 1.0" (25.4mm) range
F5 – Plastic Fibers 0.25" (6.4mm) range

White Light Source

(Broadband Color Spectrum)

The "White Light" LED light source built into the **MARK-EYE® PRO** promotes easy detection of the largest variety of color marks printed on the largest variety of colored web materials. By combining a White LED light source, our Contrast Indicator, and the one-push AUTOSSET setup, you have a winning combination of high performance with an easy to use sensor:

- The best choice for detecting printed registration marks on packaging materials
- The best choice for detecting pale yellow marks on white backgrounds

Hardware & Accessories

Micro Cable Selection Guide, 5-wire, M12



GSEC-6
6' (1.8m) Shielded cable



GSEC-15
15' (4.6m) Shielded cable



GSEC-25
25' (7.62m) Shielded cable



GSEC-2MU
6.5' (2.0m) Low-cost, unshielded



GSEC-5MU
16.4' (5.0m) Low-cost, unshielded

GRSEC-6
6' (1.8m) Right angle shielded cable

GRSEC-15
15' (4.6m) Right angle shielded cable

GRSEC-25
25' (7.62m) Right angle shielded cable

GX-25
25' (7.62m) extension cable



FMB-1 (8.4mm diam.)
Standard Fiberoptic
Mounting Bracket



SEB-3
Stainless "L" Bracket



FMB-2 (5.1mm diam.)
FMB-3 (3.1mm diam.)
Miniature Glass or Plastic
Fiberoptic Mounting
Brackets



LK-4
Lens Kit
(See Optical Blocks
Accessories for contents)

(Mark Samples)



Specifications

MARK-EYE® PRO

SUPPLY VOLTAGE

- 10 to 30 VDC
- Polarity Protected

CURRENT REQUIREMENTS

- 45 milliamps (exclusive of load)

OUTPUT TRANSISTORS

- (1) NPN and (1) PNP sensor output transistors
- Outputs sink or source up to 150 milliamps (current limit)
- All outputs are continuously short circuit protected

REMOTE AUTOSET INPUT

- Opto-isolated momentary sinking input (10 milliamps)

RESPONSE TIME

- MEP45WL – Light/Dark = 45µs
Repeatability = 13µs
- MEP – Light/Dark = 175µs

LED LIGHT SOURCE

- White LED provides detection of registration marks of the widest variations of contrasting colors

PUSH BUTTON CONTROL

- AUTOSET
- Manual Adjustments
- Set status of 5 options: 5) Lock, 4) Output Invert, and Pulse Stretchers 3) 10ms, 2) 25ms, and 1) 50ms

HYSTERESIS

- Set for high resolution ... less than one bar on the contrast indicator

LIGHT IMMUNITY

- Responds to sensor's pulsed modulated light source ... immune to most ambient light and strobes, including indirect sunlight

DIAGNOSTIC INDICATORS

- 5-LED Bargraph functions in one of two modes:
 1. Contrast Indicator... Displays scaled reading of sensor's response to contrasting light levels (light to dark)
 2. Status Indicator... Displays status of five selectable options
- Red LED output indicator ... Illuminates when the sensor's output transistors are "ON"
- NOTE: If Output LED flashes, a short circuit condition exists*
- Amber LED... Illuminates when in the options select mode
- Yellow LED... Illuminates when Lock feature is activated

AMBIENT TEMPERATURE

- -40°C to 70°C (-40°F to 158°F)



RUGGED CONSTRUCTION

- Chemical resistant high impact polycarbonate housing
- Industry Ratings: NEMA 4X, 6P, IP67

RoHS Compliant
Product subject to change without notice

Connections and Dimensions

MARK-EYE® PRO

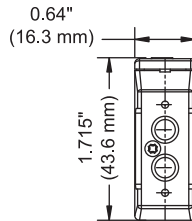
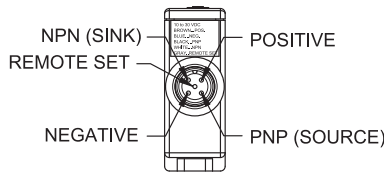

MOUNTING OPTIONS

- Direct mount to panel or bulkhead
- Din Rail
- Bracket (see below)

P/N SEB-3
Optional Mounting
Bracket With Hardware

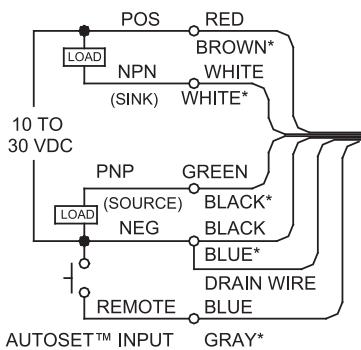
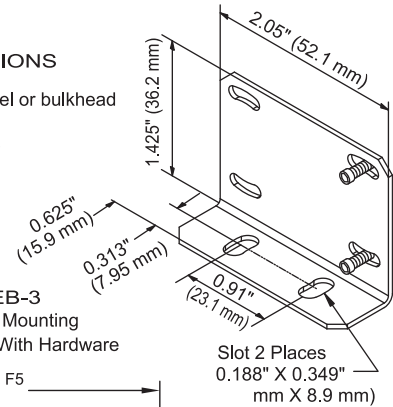

*SENSORS WITH CONNECTORS

"C" Models Have
Standard 5 Pin,
M12 Connector

