

HJMX-T / HRSMX-T / HIN-T

HIGH MISALIGNMENT SERIES - MALE ROD ENDS & SPHERICAL BEARINGS - HEAVY DUTY, PTFE LINED

HJMX-T / HRSMX-T / HIN-T
HIGH MISALIGNMENT SERIES - HEAVY DUTY

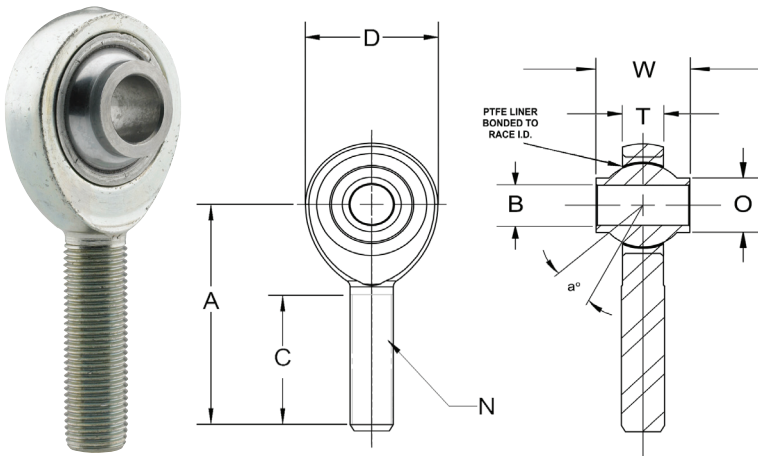

BALL	BODY
52100 STEEL HEAT TREATED HARD CHROME PLATED	4340 STEEL HEAT TREATED ZINC PLATED CHROMATE TREATED
RACE	LINER (STANDARD)
STEEL ALLOY ZINC PLATED CHROMATE TREATED	PTFE FABRIC

MALE ROD ENDS		B DIA	D DIA	W WIDTH	T WIDTH	BALL DIA	A LGTH	N THD	C LGTH	O DIA.	a° MIS ANGLE	ULT. STATIC RADIAL LOAD (lbs.)	APPROX. WEIGHT (lbs.)
RIGHT HAND PART NO.	LEFT HAND PART NO.												
HRSMX4T	HRSMXL4T	.2500 +.0015 -.0005	1.025 +.010 -.010	.593 +.005 -.005	.265 +.005 -.005	.593 REF.	1.938 +.015 -.015	3/8-24 UNF 3A	1.187 +.062 -.031	.390 REF.	23 REF.	10,790	.12
HRSMX5T	HRSMXL5T	.3125	1.150	.813	.355	.781	2.125	7/16-20	1.281	.512	22	11,789	.16
HJMX6T	HJMXL6T	.3750	1.150	.813	.355	.781	2.125	3/8-24	1.281	.512	22	11,390	.12
HRSMX6T	HRSMXL6T	.3750	1.150	.813	.355	.781	2.125	7/16-20	1.281	.512	22	11,789	.15
HJMX7T	HJMXL7T	.4375	1.337	.875	.355	.875	2.438	7/16-20	1.468	.618	21	15,716	.23
HRSMX7T	HRSMXL7T	.4375	1.337	.875	.355	.875	2.438	1/2-20	1.468	.618	21	17,100	.24
HJMX8T	HJMXL8T	.5000	1.525	.937	.411	1.000	2.625	1/2-20	1.562	.730	19	23,703	.33
HRSMX8T	HRSMXL8T	.5000	1.525	.937	.411	1.000	2.625	5/8-18	1.562	.730	19	23,703	.39
HJMX10T	HJMXL10T	.6250	1.775	1.200	.577	1.250	2.875	5/8-18	1.687	.856	19	28,109	.57
HRSMX10T	HRSMXL10T	.6250	1.775	1.200	.577	1.250	2.875	3/4-16	1.687	.856	19	32,100	.60
HJMX12T	HJMXL12T	.7500	2.025	1.280	.630	1.375	3.375	3/4-16	2.000	.970	18	38,701	.82
HRSMX12T	HRSMXL12T	.7500	2.025	1.280	.630	1.375	3.375	7/8-14	2.000	.970	18	38,701	.89

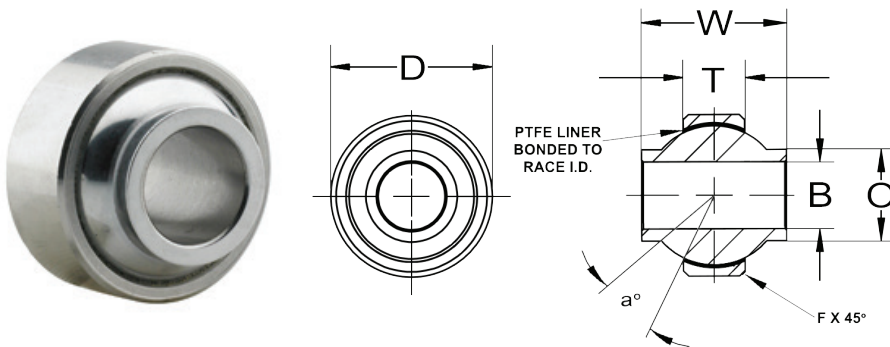

BEARING PART NO.	B DIA	D DIA	W WIDTH	T WIDTH	O DIA.	BALL DIA	F CHAMFER	a° MIS ANGLE	ULT. STATIC RADIAL LOAD (lbs.)	APPROX. WEIGHT (lbs.)
	+.0015 -.0005	+.0000 -.0005	+.005 -.005	+.005 -.005	REF.	REF.	REF.	REF.		
HIN4T	.2500	.7400	.593	.255	.390	.593	.020	24	7,560	.040
HIN5T	.3125	.9060	.813	.345	.512	.781	.030	23	16,983	.080
HIN6T	.3750	.9060	.813	.345	.512	.781	.030	23	16,983	.068
HIN7T	.4375	1.0000	.875	.345	.618	.875	.030	22	19,023	.095
HIN8T	.5000	1.1250	.937	.401	.730	1.000	.030	20	25,275	.160
HIN10T	.6250	1.3750	1.200	.567	.856	1.250	.030	20	44,652	.245
HIN12T	.7500	1.5625	1.280	.620	.970	1.375	.035	18	53,716	.315