

Rise - Standard



The Rise is an indirect asymmetric sconce or pendant luminaire with outdoor color-changing compatibility. It is the most efficient, compact, and lightweight indirect asymmetric luminaire currently available in the market.

This luminaire provides vertical illuminance with smooth and uniform distribution, and is perfect for commercial, education, hospitality, municipalities, retail, and sports-recreation areas, where the Rise can be used to illuminate high ceiling spaces the emphasize its spatial structure.

Quantity		Type	
Project		Note	

Electrical System

- Power Input: Universal (120-277V); HVT (347-480V)
- Operating Temperature: -40°F~112°F
- Surge Protection: 4 KV
- Power Factor Greater than 0.9

LED Technology

- 3000K, 4000K, 5000K
- 85 CRI, 75 CRI
- Beam Angle: Asymmetric
- Rated Life > 66,000 Hours (L70)

Advanced Dimming

(Proprietary VX Driver is incorporated to all dimming options for video flicker-free lighting)

- Standard 1-10V: dims to 10%

Housing

- Dimensions & Weight:
- Standard 110L & 190L: 13.05"x 9.84"x 4.33" (19.8 lb)
- Standard 210L & 370L: 24.86"x 9.84"x 4.33" (38.8 lb)
- With Visor 110L & 190L: 13.05"x 14.77"x 4.33" (22.9 lb)
- With Visor 210L & 370L: 24.86"x 14.77"x 4.33" (44.9 lb)
- Material: Die-Cast Aluminum, Tempered Glass

Mounting

- Wall Mount
- Stem Mount

Warranty

- 5-year limited warranty

Listing

- ETL Wet Location Listed
- IP 65
- FCC
- CE



Not all Rise Series are DLC qualified. For all qualified products. Please visit: www.designlights.org/qpl

*METEOR LIGHTING reserves the right to make changes to this product at any time without prior notice and such modification shall be effective immediately.

Rise - Standard



How to Specify:

Ordering Example: RI-110L-408-UNV-STV-ASY-WHT-WLM-GSV

4-5 weeks lead time on over 75% of specifications.

Model	*Light Source	CCT / CRI	Voltage
RI			
RISE	110L 100W Light Engine 10,900 Delivered Lumens	308 3000K / CRI85	UNV 120-277V
	190L 150W Light Engine 19,000 Delivered Lumens	408 4000K / CRI85	HVT 347V-480V
	210L 200W Light Engine 21,350 Delivered Lumens	507 5000K / CRI75	
	370L 300W Light Engine 37,200 Delivered Lumens		
*Delivered lumens shown are at 4000K CCT. See Delivered Lumens table for other CCT			

Dimming	Beam Angle	Finish	Mounting	Accessories
STV 1-10V dims to 10%	ASY Asymmetric	BLK Black WHT White	WLM Wall Mount ST4 Stem 4ft ST8¹ Stem 8 ft	GSV² Glare Shield Visor
			¹ Includes two 4ft stem connected by an adapter.	² Please factor in change in lumen output of -10%.

Delivered Lumens

Light Source \ CCT	110L	190L	210L	370L
5000K	11,500 lm	20,850 lm	22,500 lm	40,850 lm
4000K	10,900 lm	19,000 lm	21,350 lm	37,200 lm
3000K	10,150 lm	17,650 lm	19,850 lm	34,550 lm

Current Consumption

Light Source	Wattage	120V	277V
110L	100W	0.92A	0.4A
190L	150W	1.38A	0.60A
210L	200W	1.83A	0.8A
370L	300W	2.75A	1.20A

DesignLights Consortium™ Qualified Luminaires:

DLC QPL Model Number: RISE-190L-408, RISE-370L-408

Not all product variations listed on this page are DLC qualified.

To ensure that a specific model is qualified, visit www.designlights.org/search.

*METEOR LIGHTING reserves the right to make changes to this product at any time without prior notice and such modification shall be effective immediately.

Rise - Standard



Dimensions

110L & 190L / Wall Mount

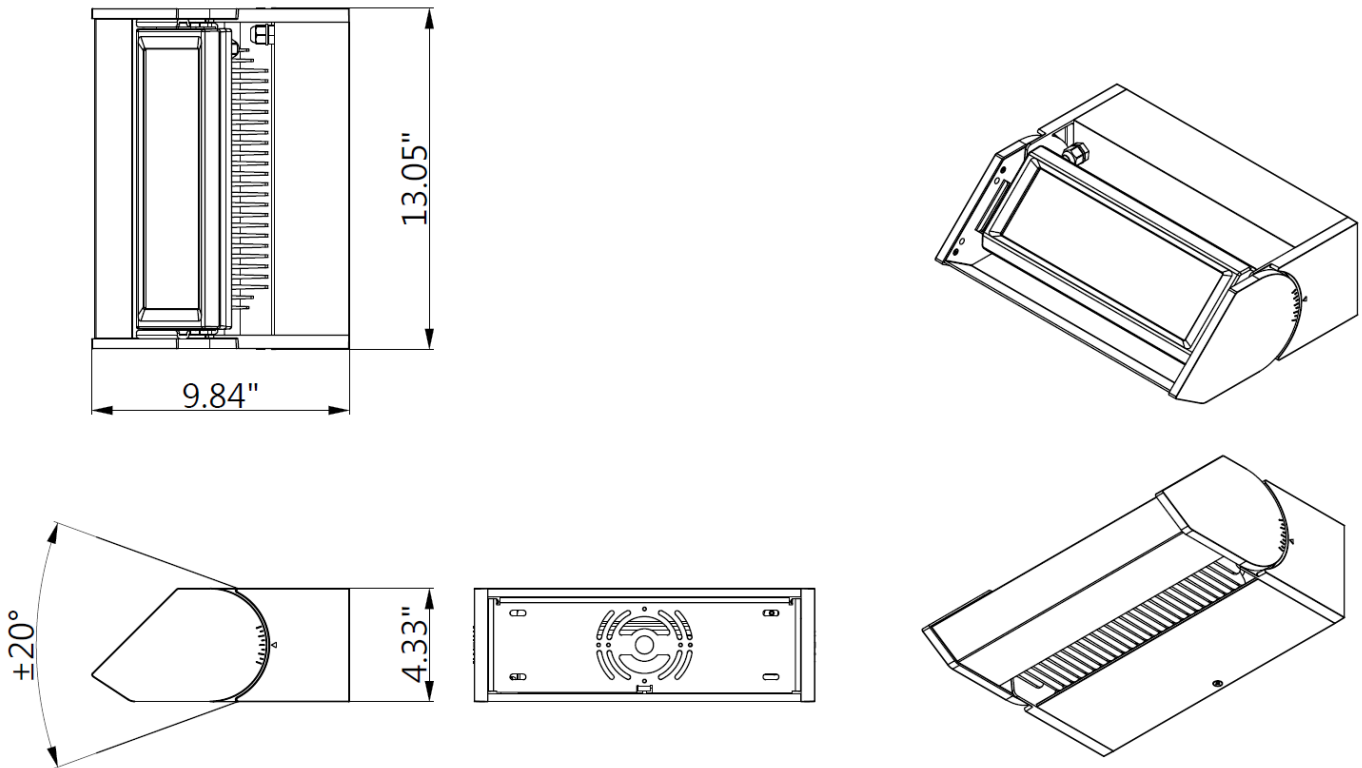

*METEOR LIGHTING reserves the right to make changes to this product at any time without prior notice and such modification shall be effective immediately.

Rise - Standard



Dimensions

210L & 370L / Wall Mount

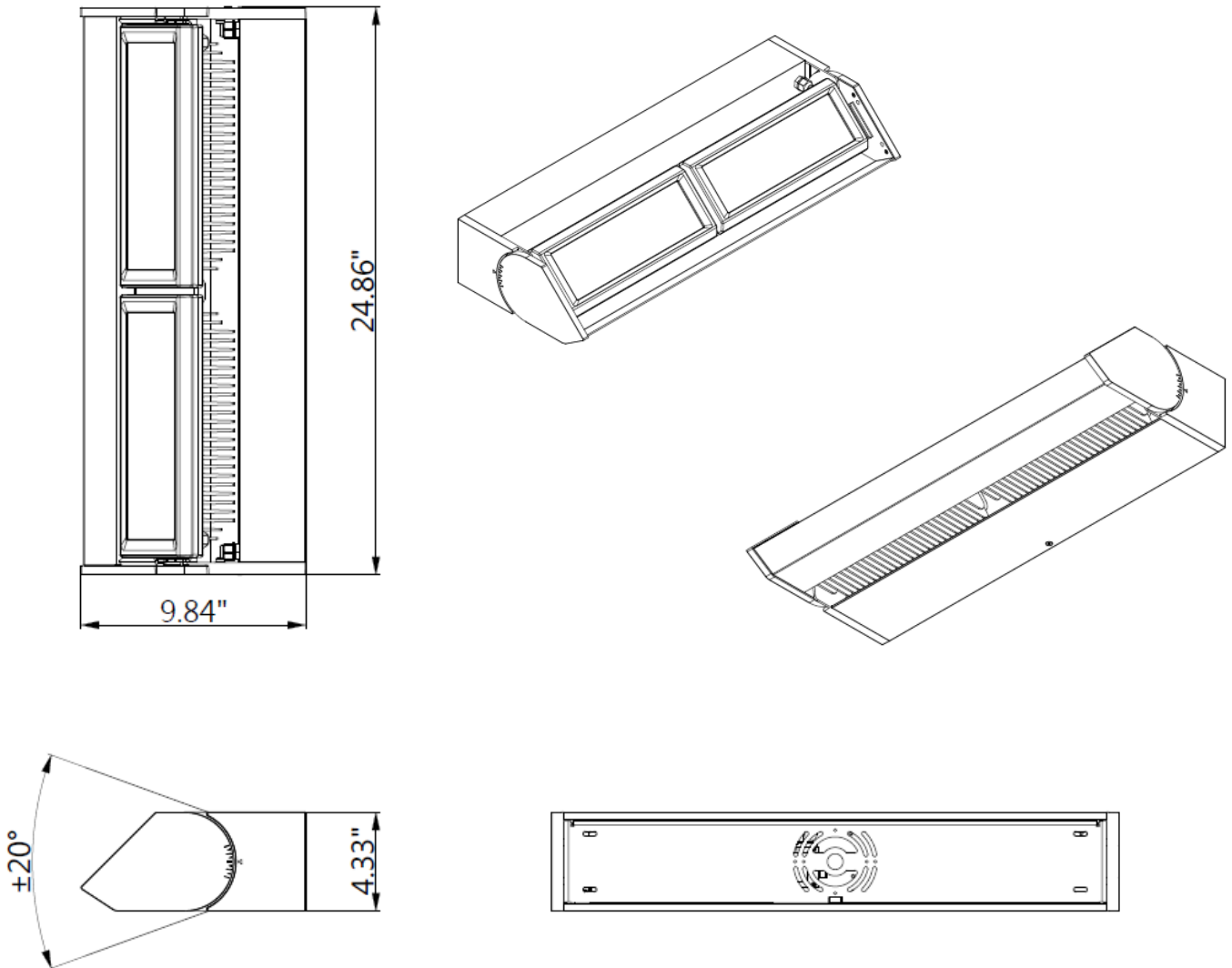

*METEOR LIGHTING reserves the right to make changes to this product at any time without prior notice and such modification shall be effective immediately.

Rise - Standard



Dimensions

110L & 190L Stem Mount

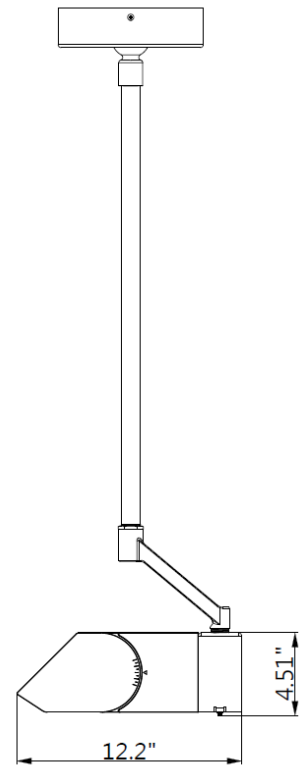
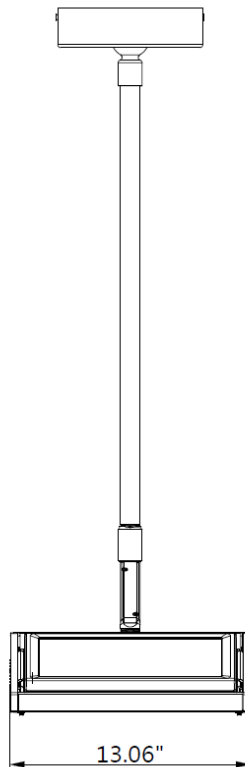
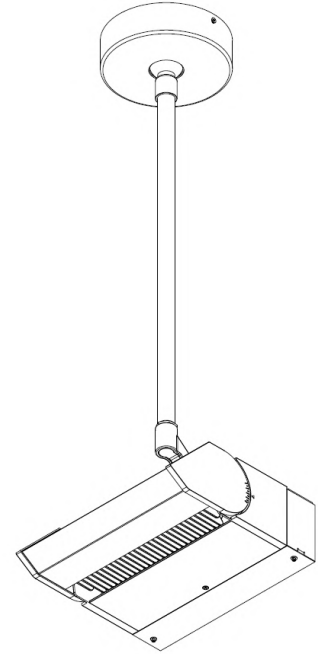
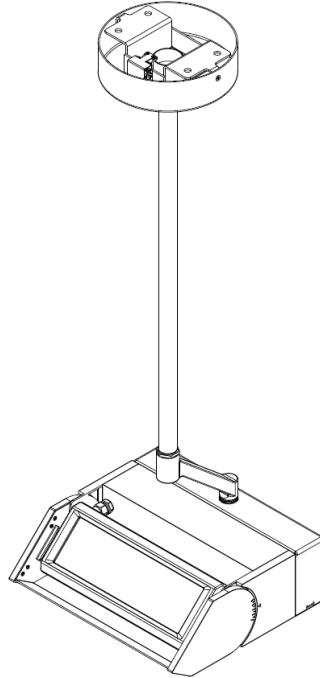
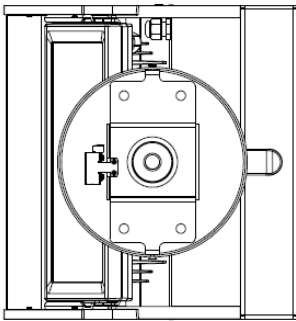

*METEOR LIGHTING reserves the right to make changes to this product at any time without prior notice and such modification shall be effective immediately.

Rise - Standard



Dimensions

210L & 370L Stem Mount

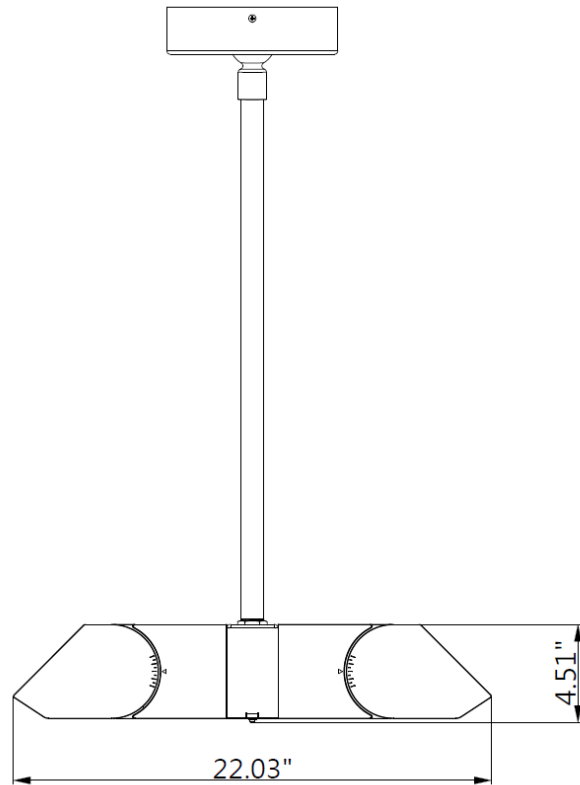
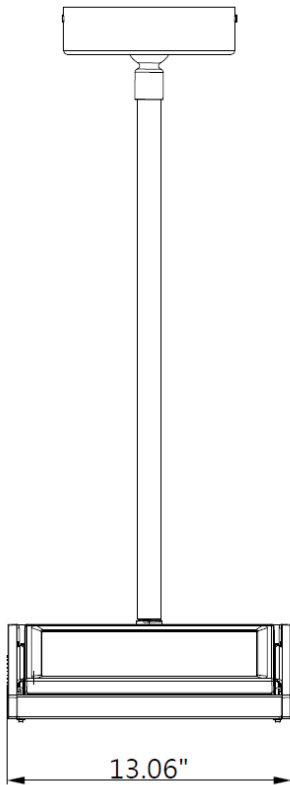
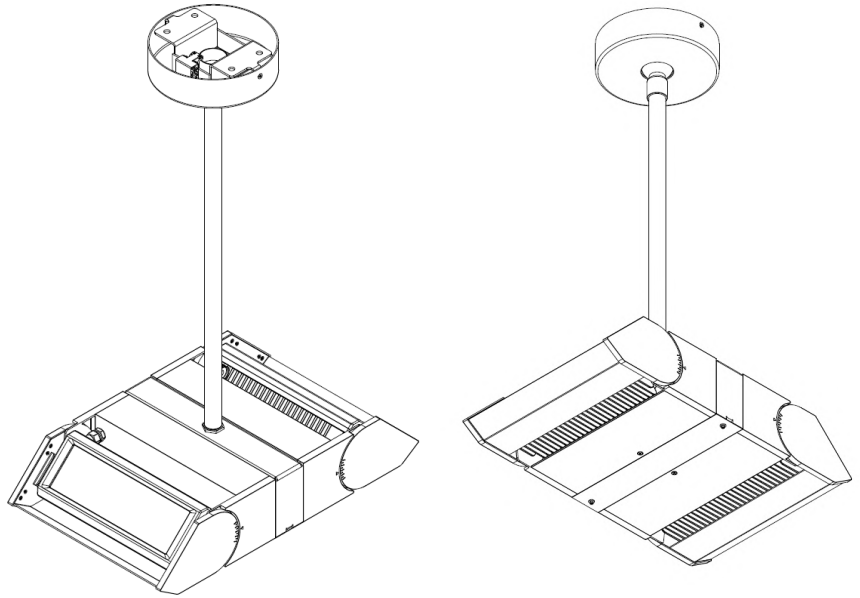
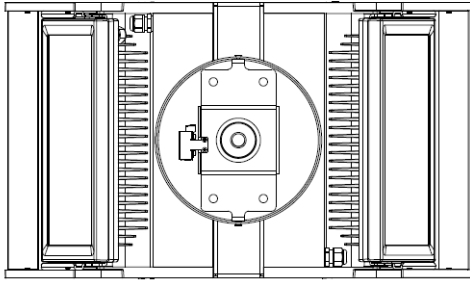

*METEOR LIGHTING reserves the right to make changes to this product at any time without prior notice and such modification shall be effective immediately.

Rise - Standard



Accessory

Glare Shield Visor

100W / 150W

200W / 300W

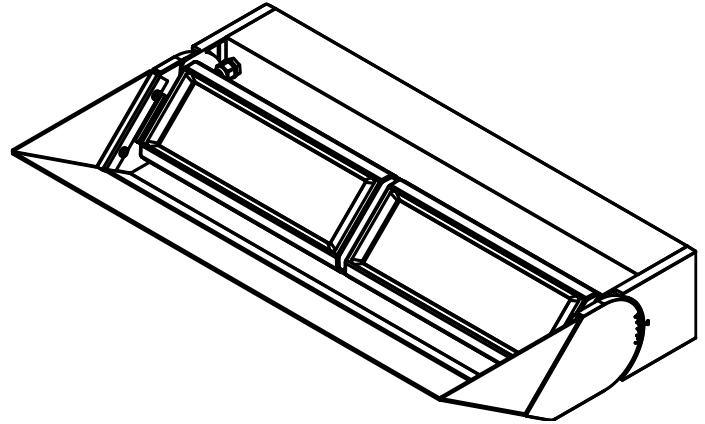
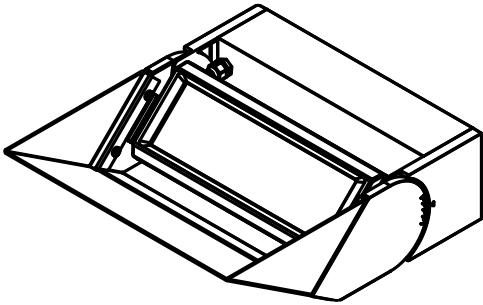

13.05"

24.86"



4.93"



4.93"

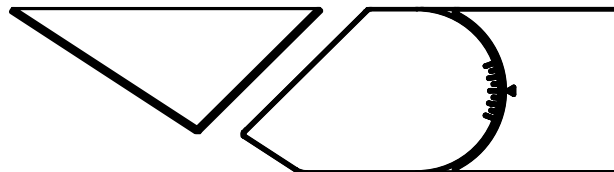
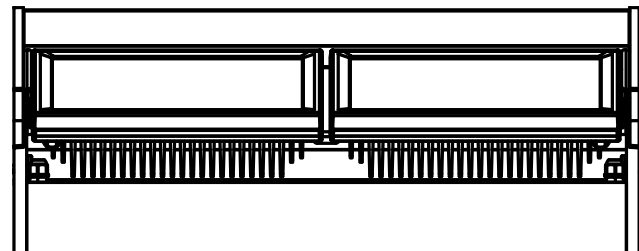
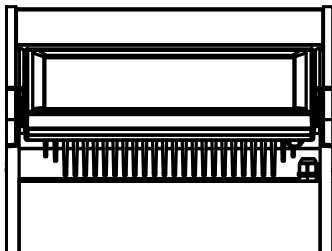

*METEOR LIGHTING reserves the right to make changes to this product at any time without prior notice and such modification shall be effective immediately.