

GALLERY LED PROFILE LUMINAIRES

50 Watt LED

The Altman Gallery series is a family of luminaires designed to serve as the most versatile solution available to facilities ranging from museums and art galleries to hotel, retail, and restaurants where aesthetic and performance expectations are high.

The foundation of this scalable luminaire family is a 50 Watt, 92+ CRI engine, that offers up to 4,000 lumens across a variety of color temperatures. The Gallery engine can be used to build a mix and match variety of solutions that includes a 15-35° and 25-50° profile. Each can be interchanged ensuring that your facility's ever changing lighting needs will have tools flexible enough to adapt.

The Altman Gallery series is available in a variety of dimming options including: local on board dimming, mains dimming by leading or trailing edge, DMX/RDM, 0-10V, and DALI. A variety of mounting options are available including standard and data track mount, pendant, portable and ceiling mount.

Product Features:

- >4,000 Lumens (color temp and driver dependent)
- Available in multiple control options: Mains Dim, Local Dim, 0-10V, DMX/RDM, and Dali **
- Available in both hard wired, track mount and portable options ***
- Available in a 25°-50° or 15°-35° Profile zooms
- Available in four (4) different Color temperatures
- High CRI >92
- Fully homogenized, non-granulated, non-pixelated, beam
- Available in Pendant, Altman Smart Track, Portable Unistrut or C-Clamp, Portable Remote Top Box and Ceiling canopy mounting options
- 50,000 hour life expectancy
- Available in white or black
- cETLus listed and CE marked for indoor applications
- Proudly made in the USA

** Consult the last page of this data sheet for control option input voltage requirements.

*** Portable options are only available in for 120-240VAC input and DMX, Local, or Mains Dim control (120VAC only).



Gallery Zoom Luminaires

For information of the complete line of Gallery luminaires please visit the Gallery Series product page on our web site at www.altmanlighting.com/product-category/gallery/



Photometric Performance

GALLERY LED LUMINAIRE PHOTOMETRIC SCORE CARD – 2700K	
CCT	2810
DUV	.0021
CRI	91
CQS	90
RE(R1-15)	87
TLCI Qa)	91.8
TM-30-15 rf	90
TM-30-15 rg	100

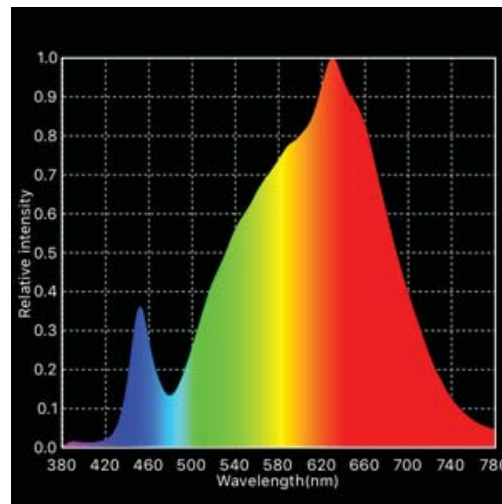
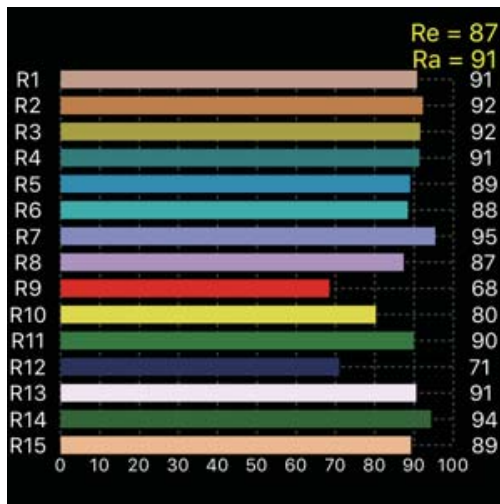

GALLERY LED LUMINAIRE PHOTOMETRIC SCORE CARD – 3000K	
CCT	3010
DUV	.0004
CRI	90
CQS	89
RE(R1-15)	87
TLCI Qa)	89.5
TM-30-15 rf	88
TM-30-15 rg	101

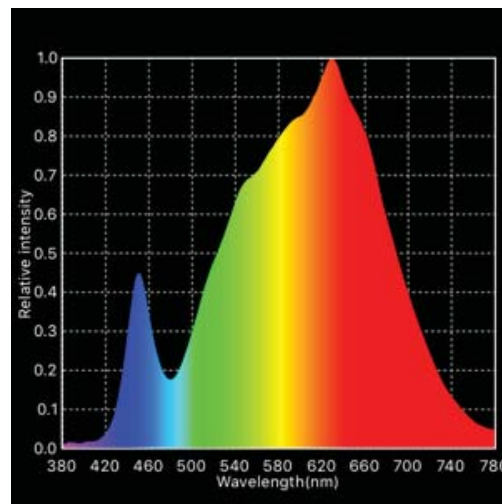
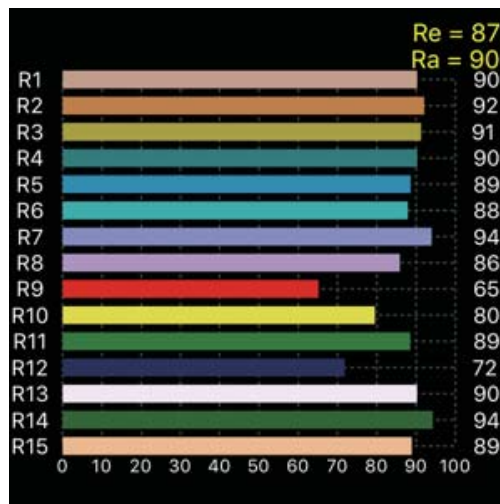

Photometric Performance

GALLERY LED LUMINAIRE PHOTOMETRIC SCORE CARD – 4000K	
CCT	4063
DUV	.0041
CRI	91
CQS	90
RE(R1-15)	87
TLCI Qa)	94.5
TM-30-15 rf	88
TM-30-15 rg	98

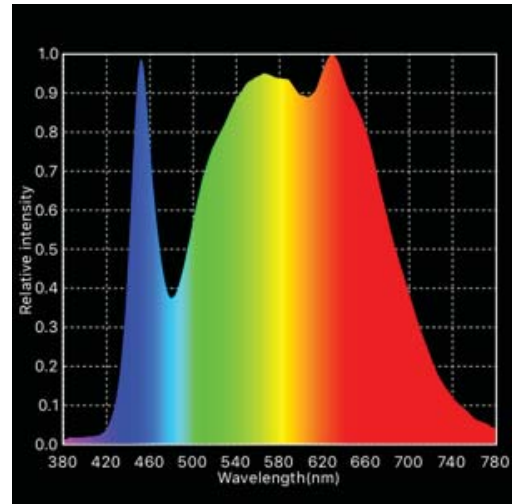
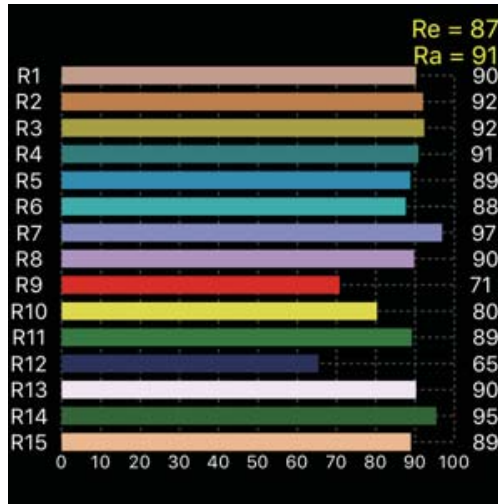

GALLERY LED LUMINAIRE PHOTOMETRIC SCORE CARD – 5000K	
CCT	5021
DUV	.0043
CRI	89
CQS	88
RE(R1-15)	85
TLCI Qa)	91.9
TM-30-15 rf	88
TM-30-15 rg	98

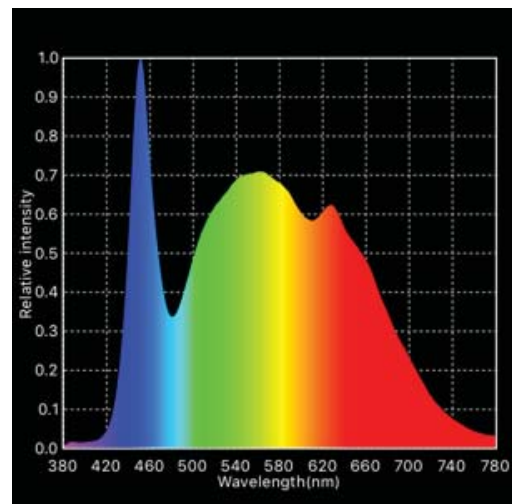
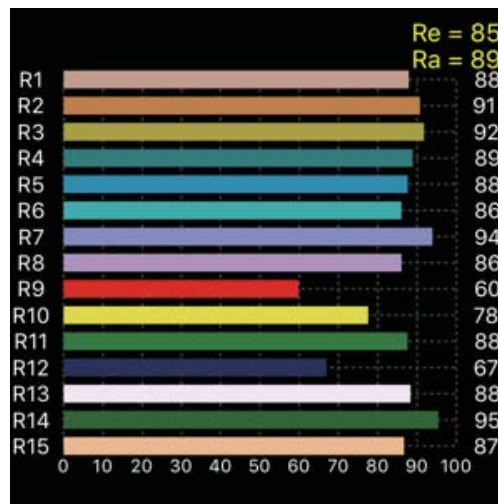

Photometric Performance - Long Zoom 15° to 30° Lens

Spot (15°)

Distance	5'-0"	10'-0"	15'-0"	20'-0"	25'-0"	30'-0"
Diameter	1'-4"	2'-8"	4'-1"	5'-5"	6'-10"	8'-2"
2,700 K	695	174	78	44	28	20
3,000 K	765	192	85	48	31	22
4,000 K	803	200	90	50	33	23
5,000 K	852	213	95	53	35	24

Medium (22°)

Distance	5'-0"	10'-0"	15'-0"	20'-0"	25'-0"	30'-0"
Diameter	1'-9"	3'-6"	5'-4"	7'-1"	8'-10"	10'-8"
2,700 K	438	109	49	27	18	12
3,000 K	482	120	54	30	20	13
4,000 K	505	127	57	31	21	14
5,000 K	536	135	60	34	21.5	15

Wide (30°)

Distance	5'-0"	10'-0"	15'-0"	20'-0"	25'-0"	30'-0"
Diameter	2'-8"	5'-5"	8'-2"	10'-11"	13'-8"	16'-4"
2,700 K	220	55	25	14	9	6
3,000 K	242	60	27	15	10	6.7
4,000 K	253	64	29	16	10.5	7
5,000 K	270	67	30	17	11	7.5

Photometric Performance - Short Zoom 25° to 50° Lens

Spot (25°)

Distance	5'-0"	10'-0"	15'-0"	20'-0"	25'-0"	30'-0"
Diameter	2'-4"	4'-7"	6'-11"	9'-3"	11'-6"	13'-9"
2,700 K	382	95	43	24	15	11
3,000 K	420	105	47	26	17	12
4,000 K	441	110	49	27	18	12.5
5,000 K	468	117	52	29	19	13

Medium (35°)

Distance	5'-0"	10'-0"	15'-0"	20'-0"	25'-0"	30'-0"
Diameter	3'-0"	6'-0"	9'-1"	12'-1"	15'-2"	18'-2"
2,700 K	179	45	20	11	7	5
3,000 K	197	50	22	12	8	5.5
4,000 K	206	52	23	13	8.5	6
5,000 K	219	55	25	14	9	6.3

Wide (50°)

Distance	5'-0"	10'-0"	15'-0"	20'-0"	25'-0"	30'-0"
Diameter	4'-0"	8'-1"	12'-1"	16'-2"	20'-3"	24'-3"
2,700 K	100	25	11	6	4	3
3,000 K	110	28	12	7	4.5	3.3
4,000 K	115	29	13	7.5	4.8	3.5
5,000 K	123	31	14	8	5	4

All Gallery photometric testing is taken following a full luminaire warm up of over an hour. Photometric performance measurements are taken at the luminaires beam angle, for field angle calculations please consult the Gallery IES files published at www.altmanlighting.com.

Dimensional Drawings

15° to 35° Long Zoom Models

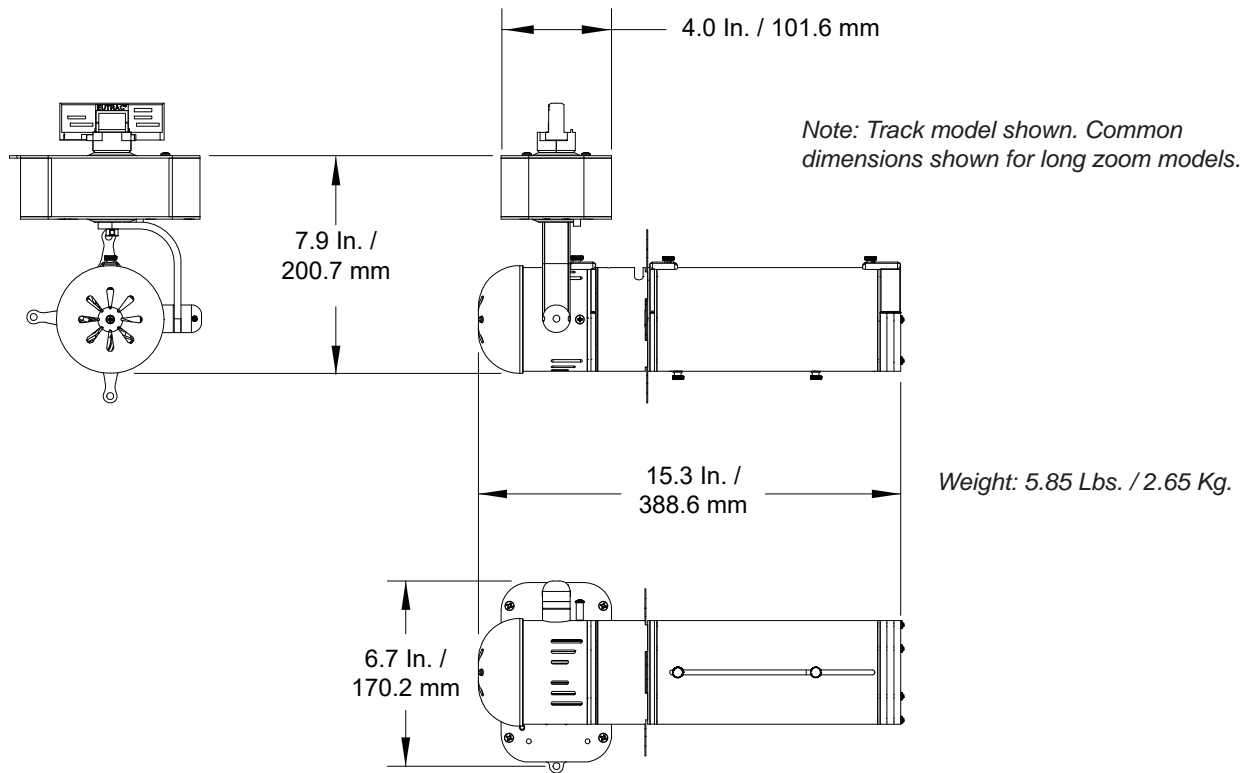

25° to 50° Short Zoom Models

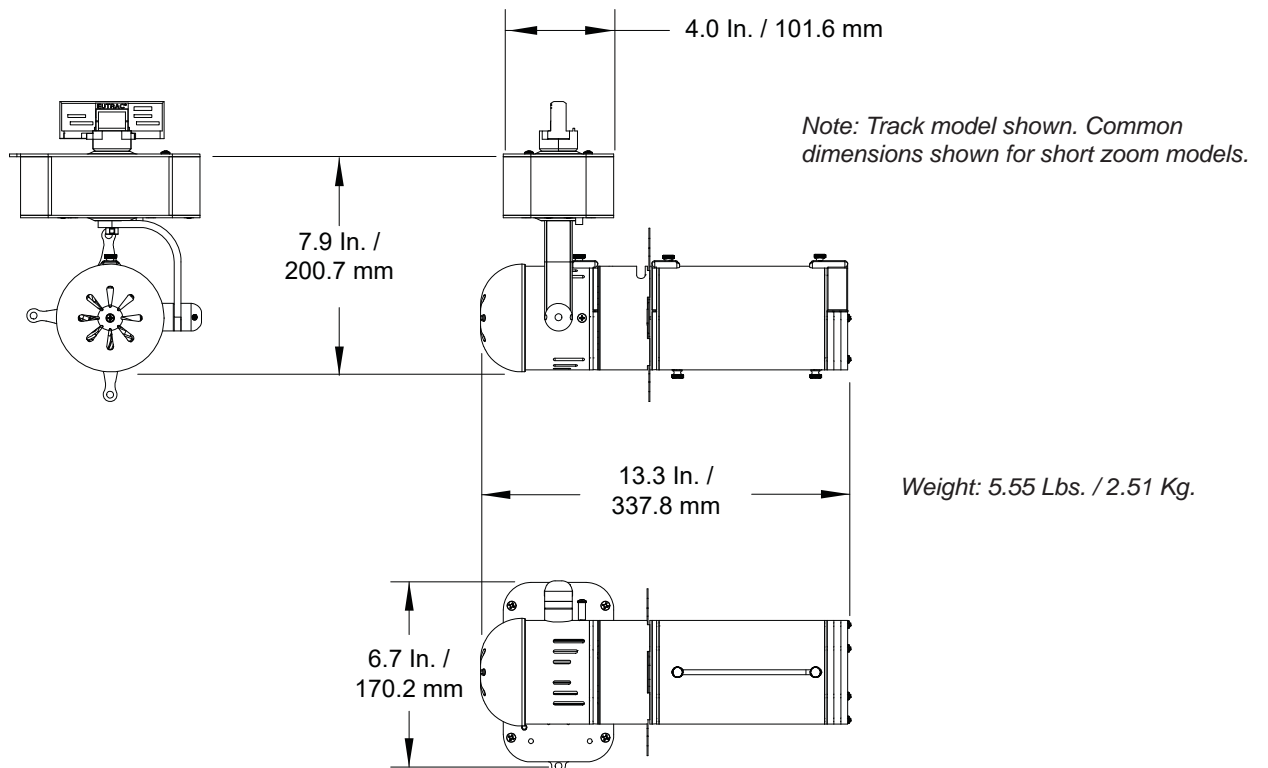

All drawings not to scale.

Specifications

Materials:	Construction employs all corrosion-resistant materials and hardware.
Control:	Mains Dimmable (120VAC only), Local Dim, 0-10V, Dali, and DMX (Fully RDM Compliant)
Light Engines:	DALI/DMX Models: 50W - Available in 2700K, 3000K, 4000K, and 5000K White. MAINS/0-10V Models: 52W - Available in 2700K, 3000K, 4000K, and 5000K White.
Lumens/Watt:	DALI/DMX Models: 80 MAINS / 0-10V Models: 76.9
BTUs/Hour:	DALI/DMX Models: 170.6 MAINS / 0-10V Models: 177.32
Input Voltages:	

Pendant/Track/Ceiling Models (non-portable)

DMX/DALI/LOCAL/0-10 Control:	100-277VAC 50/60Hz
Mains Dim:	120 VAC 60Hz

Portable Models (including Remote Top Box models)

DMX/LOCAL Control:	100-240VAC 50/60Hz
Mains Dim:	120 VAC 60Hz

Note: All voltages shown have a +/- 10% input tolerance.

Current Draw:	0.41A @ 120VAC / 0.20A @ 240VAC
Power Factor:	> 0.92 @ Full Load (Mains Dimmable Models)
Cooling:	Active Cooling (< 8 dBA @ 0.5 meters)
Environment:	0 to 40 degrees C (32 to 104 degrees F) / 5%-95% Non condensing
Weight:	Refer to dimensional drawings in this document
Compliance:	cETLus Listed, CE marked

Notes:

Altman Lighting Gallery DMX controlled luminaires are fully compliant RDM E1.20 devices. In order to set a DMX address on a Gallery luminaire, a compliant RDM Addressing device is required (sold separately). Please refer to Altman Lighting Part Number 61-0265. Prior to leaving the Altman factory, each DMX model of the Gallery luminaire is factory set to a DMX address of 1.

Ceiling and pendant mounted units utilize a 3-1/2-inch (88.9mm) screw spacing for the ceiling mount flange and fit a standard octagonal ceiling box (by others).

DMX and DALI Ceiling and Pendant Mounted units also include part numbers 51-1709451 (Male Terminal Plug) and 51-1709459 (Female Terminal Plug) for DMX/Dali Data connections.

For information of the complete line of Gallery luminaires please visit the Gallery Series product page on our web site at www.altmanlighting.com/product-category/gallery/

Ordering Information

GAL-(Lens)-(LED)-(Body Color)-(Control)-(Mounting)

Model:	GAL (Gallery LED Profile Luminaire)
Lens:	2550 (25°-50° short zoom) or 1535 (15°-35° long zoom) or NL (No Lens)
LED Array:	2K (2700K), 3K (3000K), 4K (4000K) or 5K (5000K)
Body Color:	Black (B) or White (W)
Control:	D (DMX Control), M (Mains Dimmable)*, 0 (0-10V), L (Local Control) or DA (Dali)
Mounting:	Y (Smart Track, 120V - 2 Circuit**), T (Track, refer to available track options on Altman web site), C (Ceiling), P (Pendant), PBC (Portable, supplied with C-Clamp), PBU (Portable, supplied with Unistrut nut and bolt), PBRTBC (Portable Remote Top Box with C-Clamp), or PBRTBU (Portable Remote Top Box with Unistrut Mount)

Notes:

*Mains Dimmable models are only available in 120VAC.

**For 230V Smart Track applications, use "T" for track mount and add part number TLA-99759 (add "-3" for white track head or "-2" for Black Track Head).

Portable units only available in DMX, Mains Dim, and Local Dim models)

Remote top box units have a 1 meter cable between the luminaire engine and top box.

When ordering the NL (no lens) model, lenses will need to be ordered separately - see optional accessories below. Gallery fixtures are designed for use with one of the optional lenses below. Gallery fixtures should never be operated without a lens attached.

Optional Accessories

GAL2550LT*	Additional 25°-50° Short Zoom Lens Tube**
GAL1535LT*	Additional 15°-35° Long Zoom Lens Tube**
GALGALT*	Additional Gate Assembly (required for zoom models)
61-0265	RAD (Remote Authorization Device) for addressing fixtures via RDM (Required for DMX Model)
MSC	Mini Safety Cable (one included with fixture)
GALTH*	Top Hat
GALHTH*	Half Top Hat
GALGH	Gobo Holder - E Size (37.5mm OD) (28mm image area), glass or steel patterns.
GALGOBO-RTR	Gallery Gobo Rotator (refer to Gallery Gobo Rotator specification sheet for details)
GALCF*	Gallery Color Frame, 2-15/16-inches (74.6mm) dia.
RJ45F-DMXF	RJ45 Female to DMX 5 pin Female**
RJ45F-DMXM	RJ45 Female to DMX 5 pin Male**
54-VL012405200	Additional molded VLock IEC to Edison 2 meter (6'-6") cable (note one (1) is included with portable units)

Notes:

* For these optional accessories, specify color Black (B) or White (W).

** GAL2550LT and GAL1535LT require GALGALT (gate assembly). If fitting a GAL2550LT or GAL1535LT to a fixture without a GALGALT, one must be purchased separately.

*** All portable units use RJ45 connectors for DMX connectivity. For connectivity to any DMX 5 pin system please utilize part numbers RJ45F-DMXF and RJ45F-DMXM