

LEITNER

ACSROF



LOW ROOF UNIVERSAL

LEITNERDESIGNS.COM | SALES@LEITNERDESIGNS.COM | 949-395-3049

ASSEMBLY / INSTALLATION INSTRUCTIONS:

ROOF PART NUMBERS:

- 00-5.0ULR-1650 (5'-0" ROOF PLATFORM)
- 00-5.6ULR-1648 (5'-1/2" ROOF PLATFORM)
- 00-6.0ULR-1651 (6'-0" ROOF PLATFORM)
- 00-6.6ULR-1649 (6'-1/2" ROOF PLATFORM)

TOOLS REQUIRED

- TORQUE WRENCH
- T30 TORX BIT SOCKET
- T40 TORX BIT SOCKET
- 13MM WRENCH

INSTALLATION TIME

1-1.5 HOURS

BASIC KNOWLEDGE OF HAND TOOLS REQUIRED

SKILL LEVEL



2= NOVICE

▼ READ BEFORE INSTALLING ACS ROOF ▼

1. DON'T OVER-TIGHTEN BOLTS. ALL 8MM BOLTS = (16FT-LB) ALL 6MM BOLTS = 2FT-LB)

2. LAY DOWN A LARGE AREA OF CARPET OR BLANKETS AS A WORK AREA TO AVOID SCRATCHING PARTS DURING ASSEMBLY.

3. TAKE YOUR TIME TO DO IT RIGHT, MEASURE TWICE, DRILL ONCE.

4. ALTHOUGH THE ACS ROOF IS LIGHT HAVING A FRIEND TO HELP IS RECOMMENDED.

▼ ASSEMBLY OVERVIEW ▼

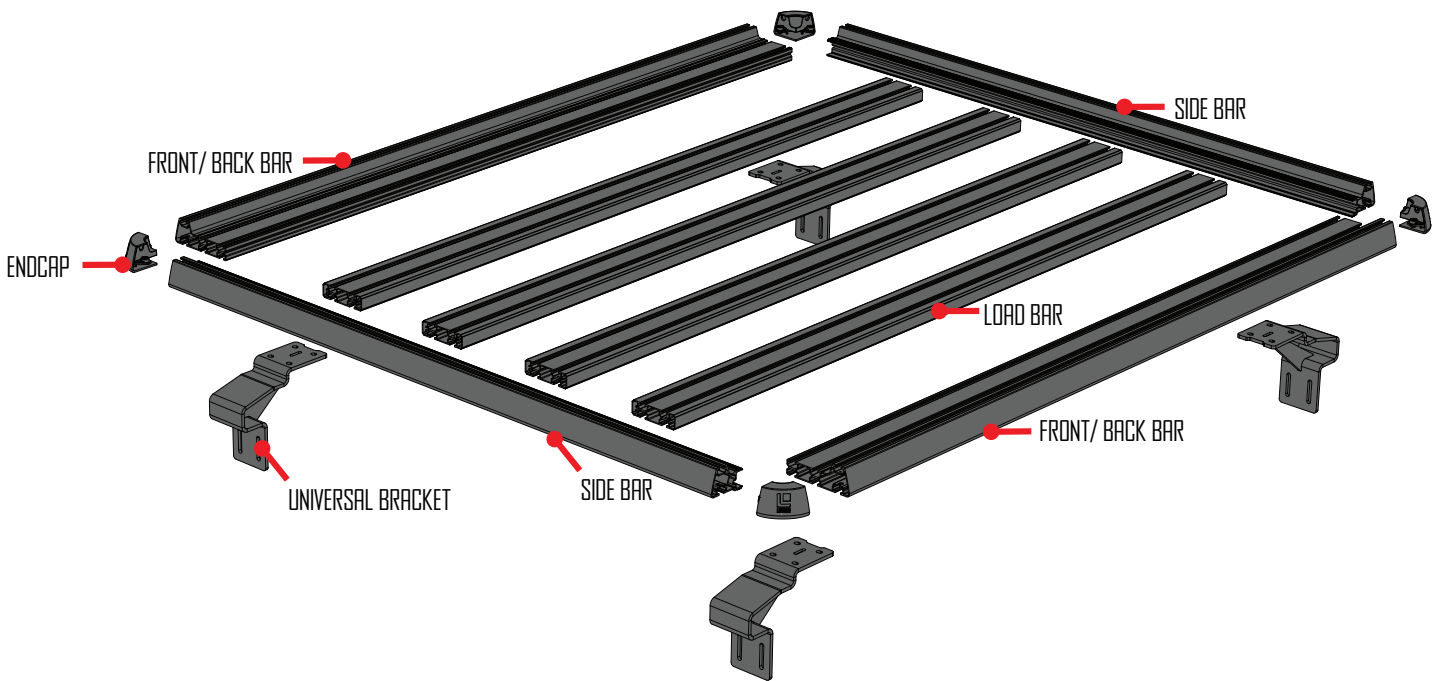

▼ ACS ROOF UNIVERSAL HARDWARE ▼

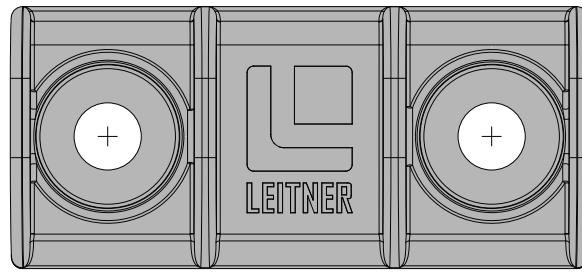

CLAMP PLATE
-[X16]-

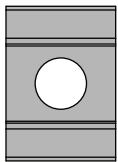

SINGLE T-NUT
-[X32]-

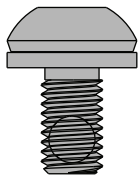

M8 X 14
-[X32]-

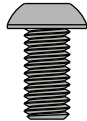

M6 X 12
[X8]

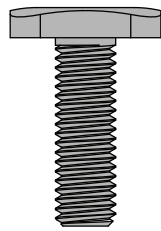

M8 X 25 SQUARE BOLT
[X16]

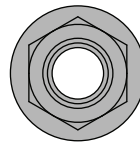

M8 LOCK NUT
[X24]

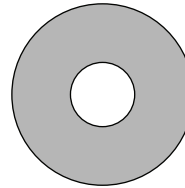

M8 X 24 WASHER
[X8]

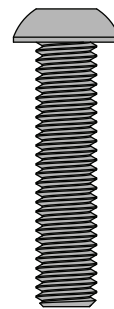

M8 X 35
[X8]

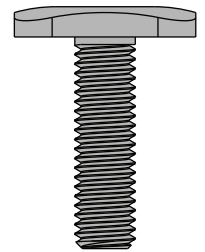

M8 X 28 RAIL BOLT
[X8]

PREP: CLAMP PLATE

- INSTALL TWO M8 X 14 BOLTS THROUGH CLAMP PLATE AND THREAD INTO T-NUT. DO NOT TIGHTEN.
- REPEAT FOR ALL PLATES
- SET ASIDE FOR USE IN NEXT STEP

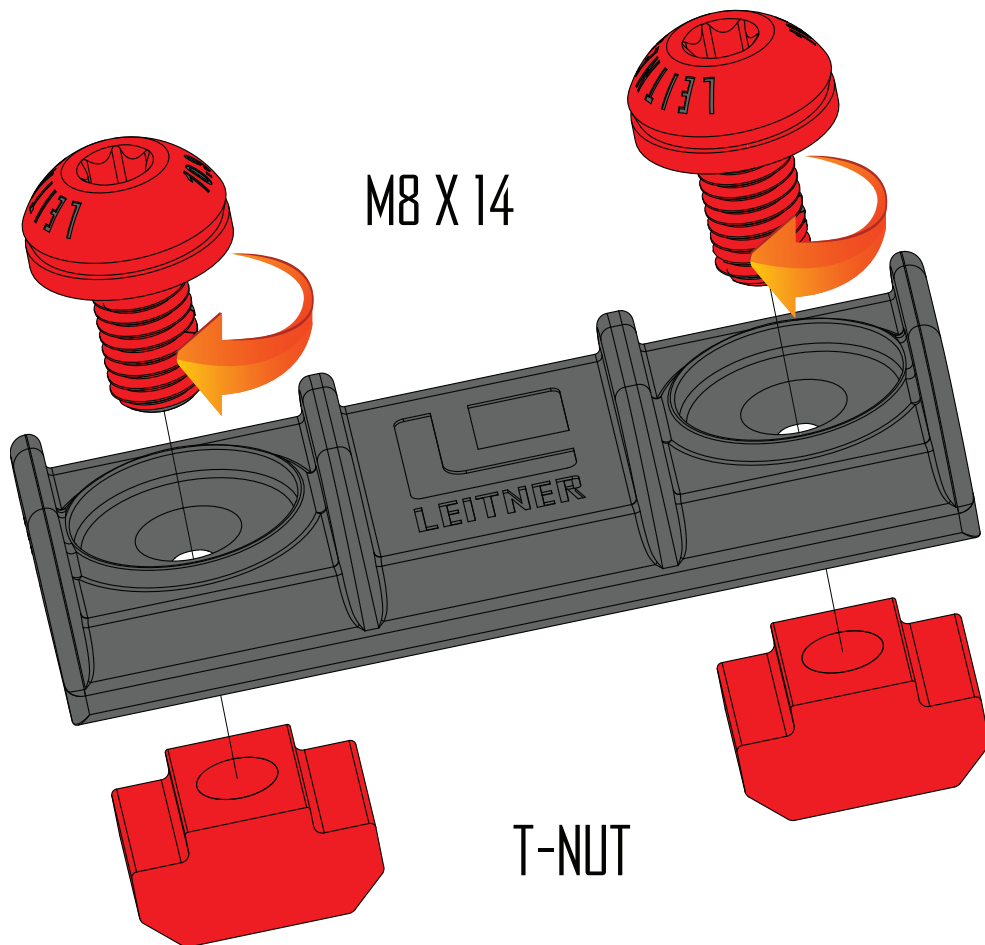

PREP: PREP FRONT AND REAR BARS

- INSTALL EIGHT **M8 X 25** T-BOLTS (4 IN EACH T-SLOT) IN BOTH FRONT/BACK BAR AS SHOWN. **DO NOT FORGET THIS STEP!!**
- INSTALL 2 CLAMP PLATE ASSEMBLIES **PER SIDE** INTO THE FRONT/BACK BARS AS SHOWN. MAKE SURE THE TEETH ON THE CLAMP PLATE FACE OUT.

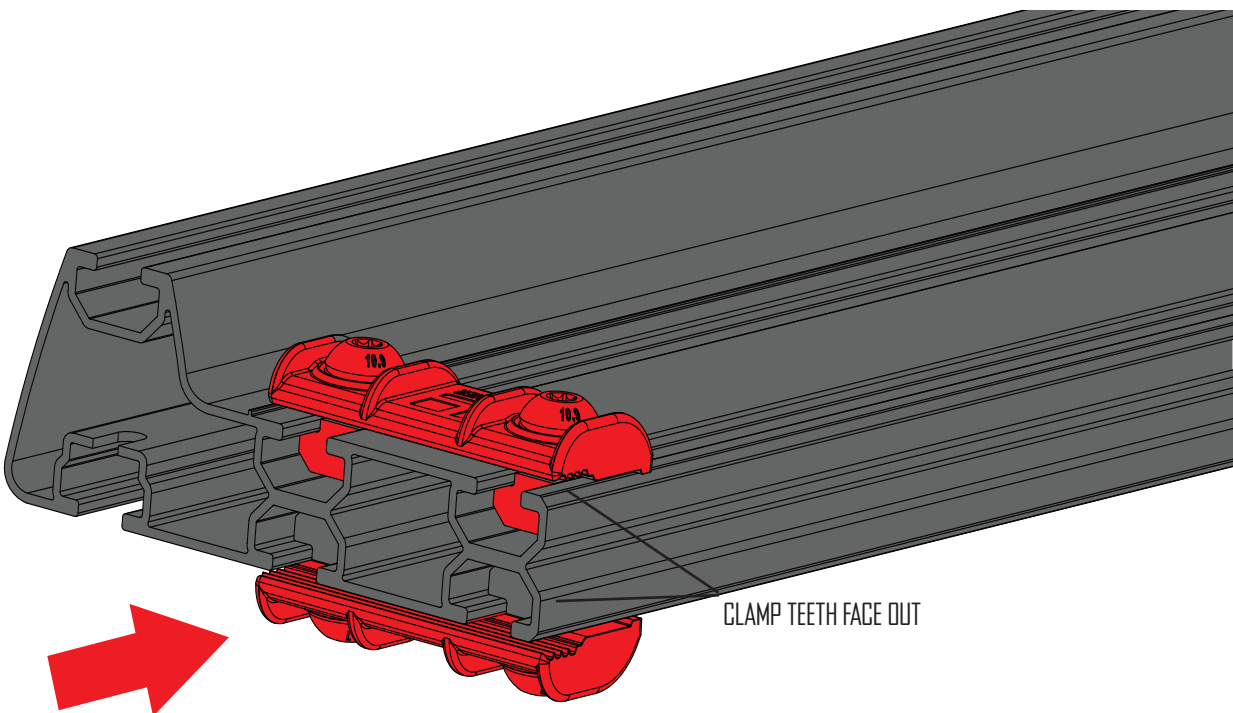
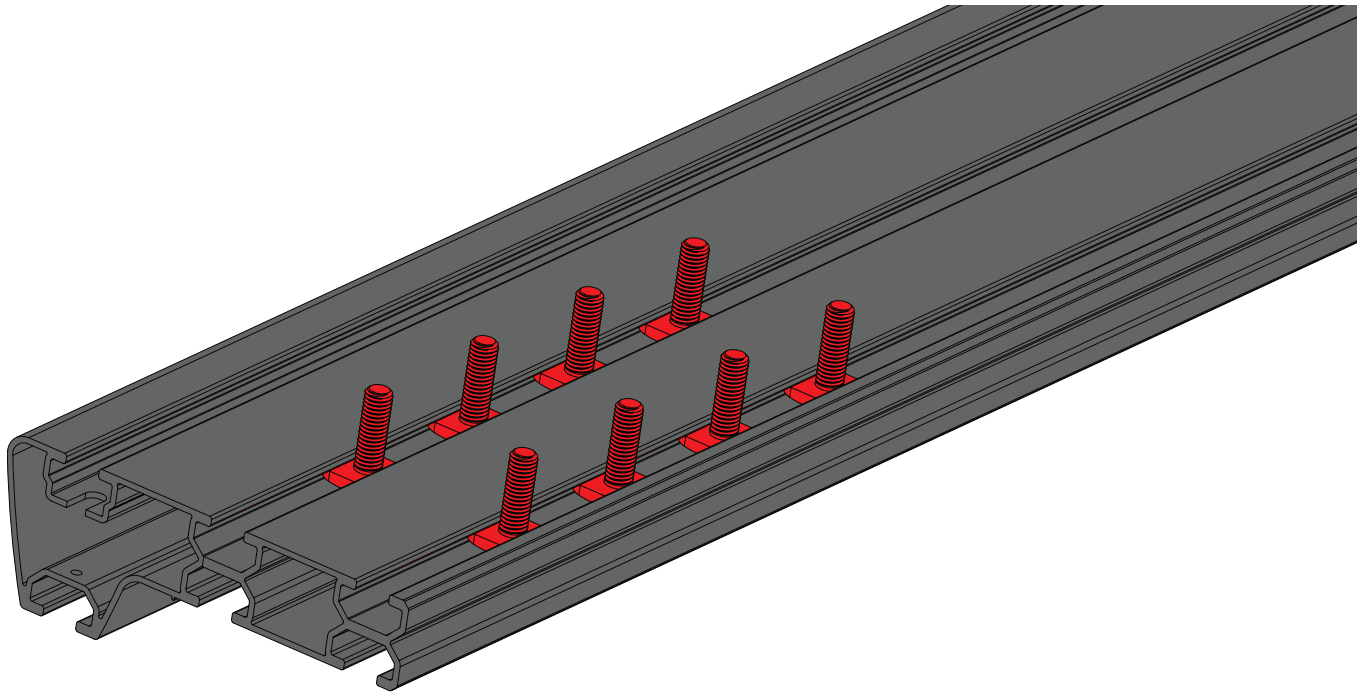

ASSEMBLE: FRAME OF RACK

• ON A SOFT WORKING SURFACE LAY OUT THE FOUR ALUMINUM EXTRUSION BARS AS SHOWN. WE RECOMMEND A MOVING BLANKET LAYED OUT ON A FLAT FLOOR AS THE RACK IS TOO LARGE TO ASSEMBLE ON A TABLE.



ASSEMBLE: RACK CORNERS

• PUSH ONE OF THE CORNERS OF THE RACK TOGETHER AS SHOWN BELOW. MAKE SURE THE SIDE BAR TOUCHES OFF AS SHOWN ON THE STOP LIP ON THE FRONT/BACK EXTRUSION (**YELLOW SURFACES**). ALSO MAKE SURE THE FRONT/BACK BAR FULLY TOUCHES THE INSIDE OF THE SIDE BAR (**BLUE SURFACES**). YOU CAN MAKE SURE EVERYTHING IS AT A 90 BY USING A CARPENTERS SQUARE (**FIG 1**)

• ADJUST THE CLAMP SO ALL THE TEETH LINE UP WITH THE GROVES IN THE SIDE EXTRUSION (**RED SURFACES**). TIGHTEN THE BOLTS USING A T40 TORX WRENCH TO 16 FT-LB (**FIG 2**)

• REPEAT STEP FOR ALL 4 CORNERS. AFTER YOU ARE SURE EVERYTHING IS SQUARE FLIP THE ASSEMBLY OVER AND TIGHTEN LOWER CLAMPS.

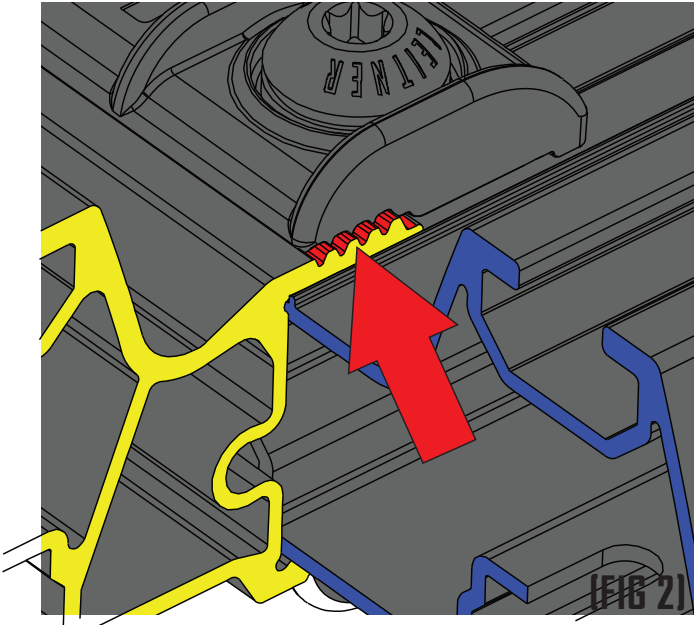
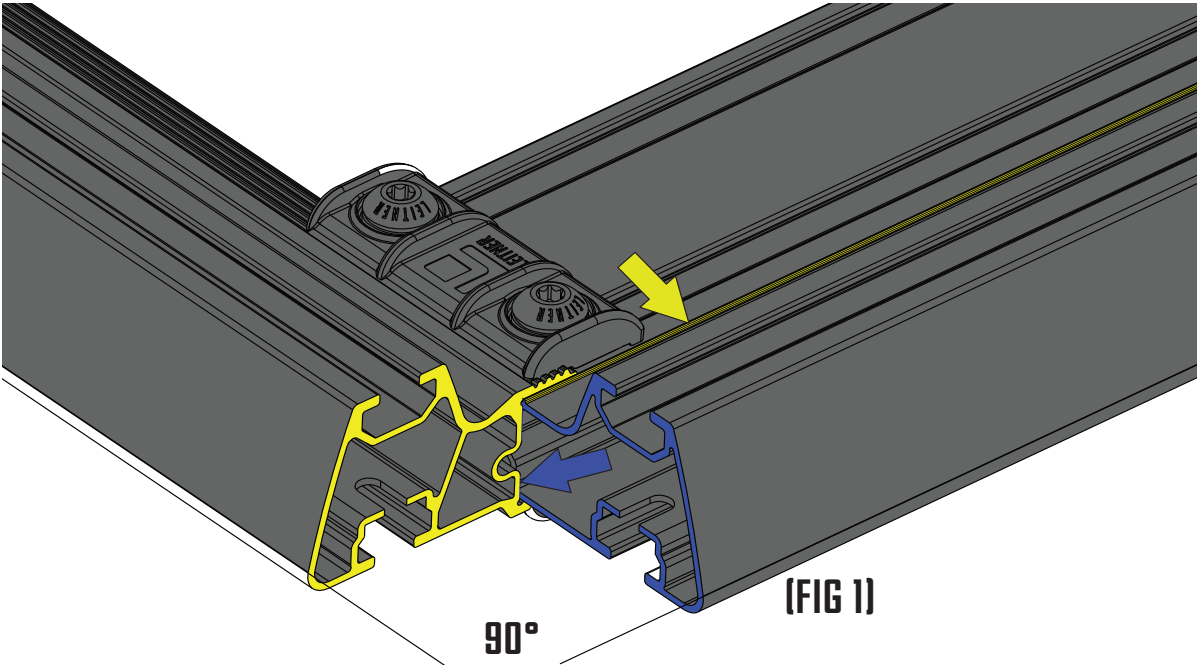

PREP: LOAD BARS

- INSTALL 1 CLAMP PLATE ASSEMBLIES **PER SIDE** INTO THE LOAD BARS AS SHOWN. MAKE SURE THE TEETH ON THE CLAMP PLATE FACE OUT.
- INSTALL THE LOAD BAR INTO THE SIDE EXTRUSION BY ANGELING IT IN AS SHOWN IN THE DIAGRAM.
- REPEAT STEPS FOR ALL INCLUDED LOAD BARS. YOU CAN BUY EXTRA LOAD BARS AND INSTALL THEM AT ANY TIME UP TO MAKE A FULLY FLAT PLATFORM.
- EVEN SPACING FOR INCLUDED LOAD BARS IS SHOWN ON NEXT PAGE.

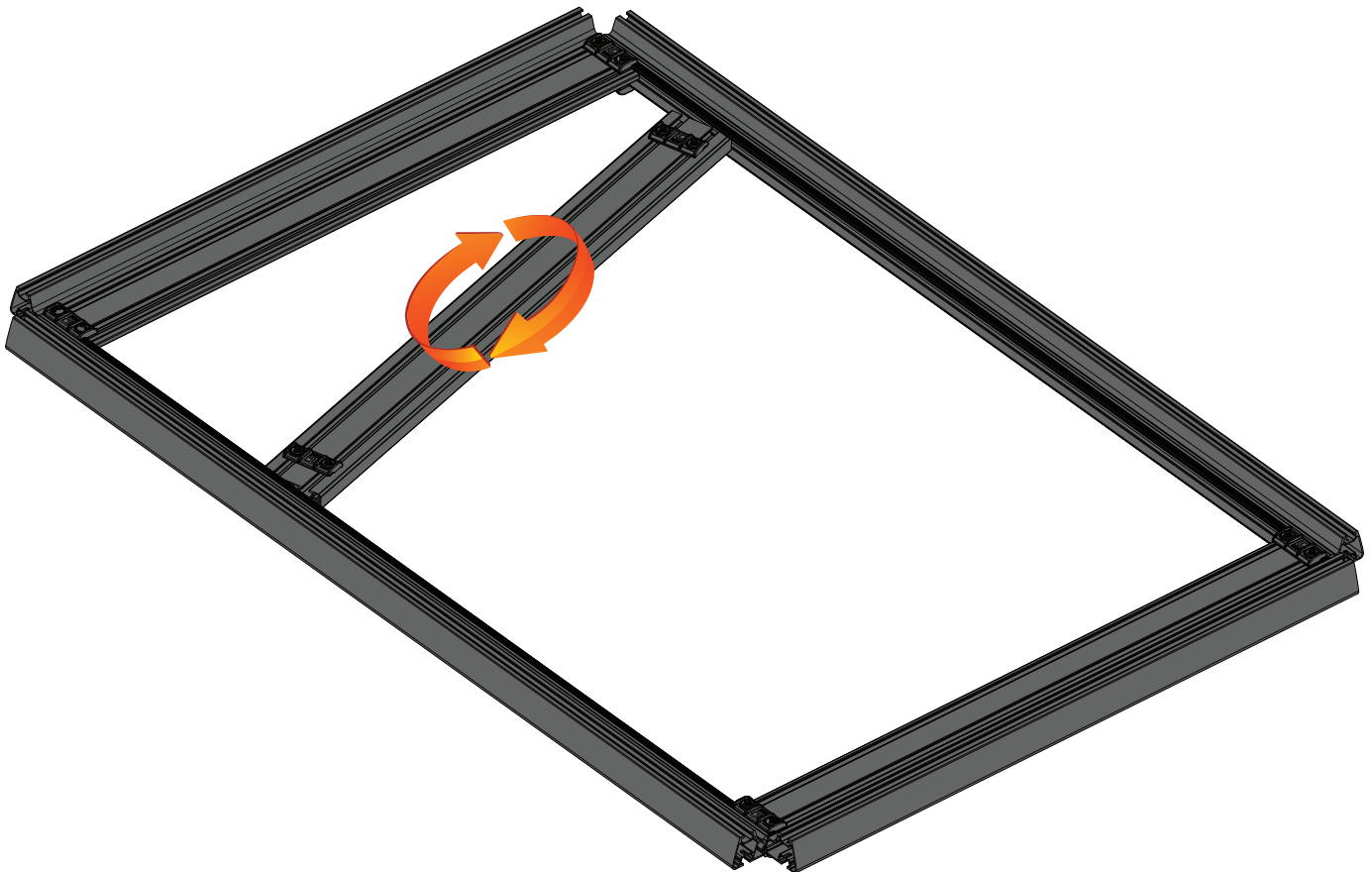
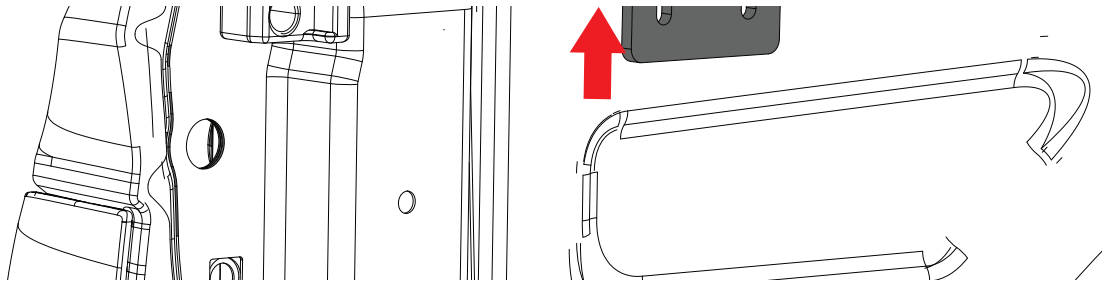

ADJUST: LOAD BAR DISTANCE

• THE LOAD BARS ARE DESIGNED TO SLIDE AND CAN BE POSITIONED ANYWHERE ALONG THE SIDE RAIL. YOU CAN ALSO ADD AS MANY LOAD BARS AS YOU LIKE UP TO AN ALMOST FULLY FLAT PLATFORM. HOWEVER IF YOU WOULD LIKE EVENLY SPACED LOAD BARS THE DIMENSIONS ARE BELOW.

00-5.0ULR-1650 (5'-0" ROOF PLATFORM) **X=5"**

00-5.6ULR-1648 (5'-1/2" ROOF PLATFORM) **X=6"**

00-6.0ULR-1651 (6'-0" ROOF PLATFORM) **X=7"**

00-6.6ULR-1649 (6'-1/2" ROOF PLATFORM) **X=9"**

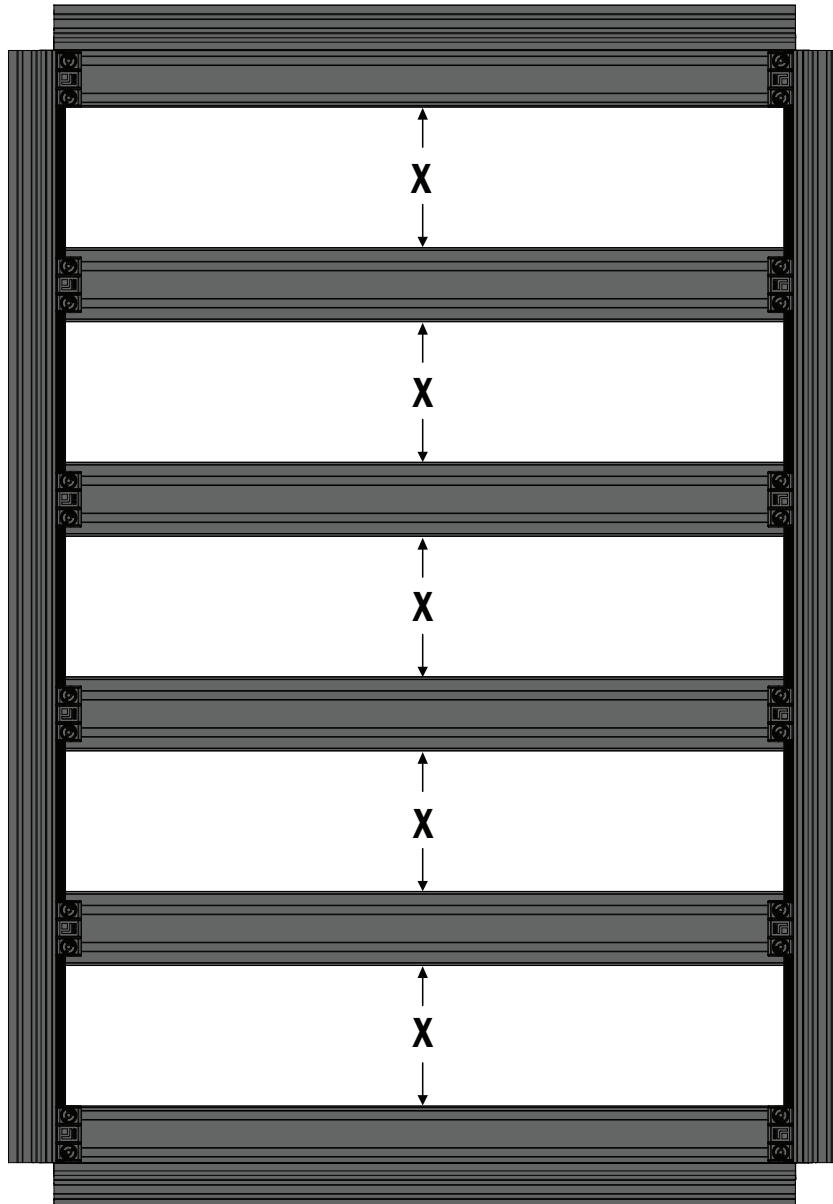

ASSEMBLE: ENDCAPS

- ASSEMBLE THE PLASTIC RETAINER INTO THE CORNER CAP AS SHOWN BELOW. **(FIG 1)**
- USING TWO M6 X 12 FASTENERS SECURE THE ENDCAPS TO THE CORNERS OF THE RACK **(FIG 2)** TIGHTEN TO 24 IN-LB USING A T30 TORX WRENCH.

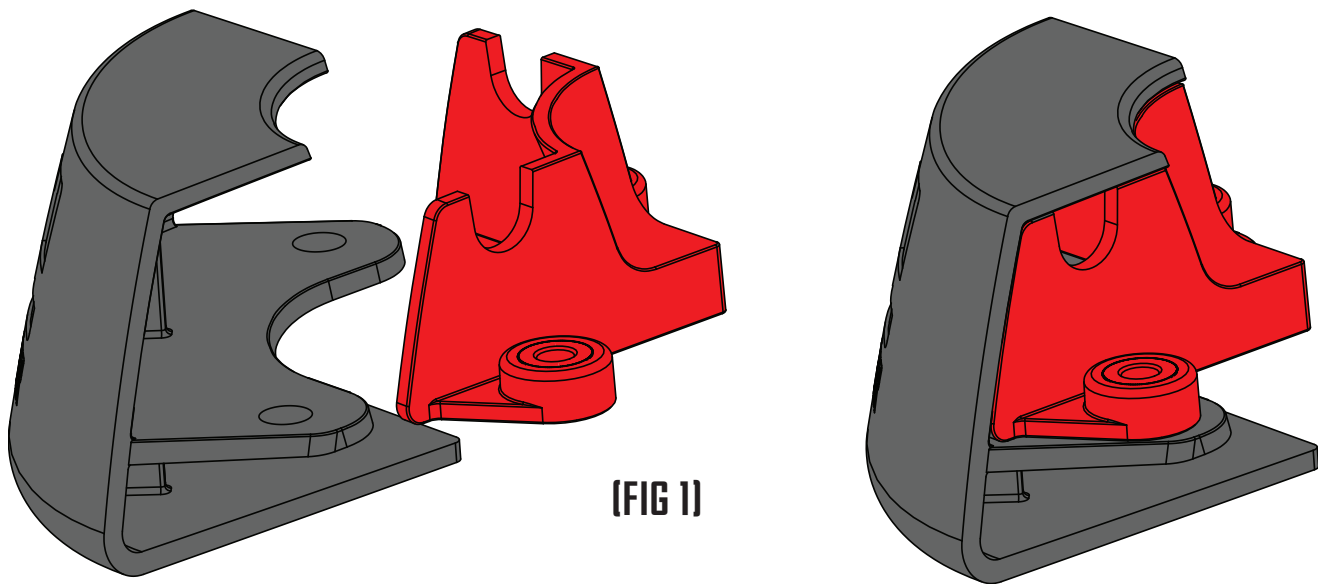

(FIG 1)

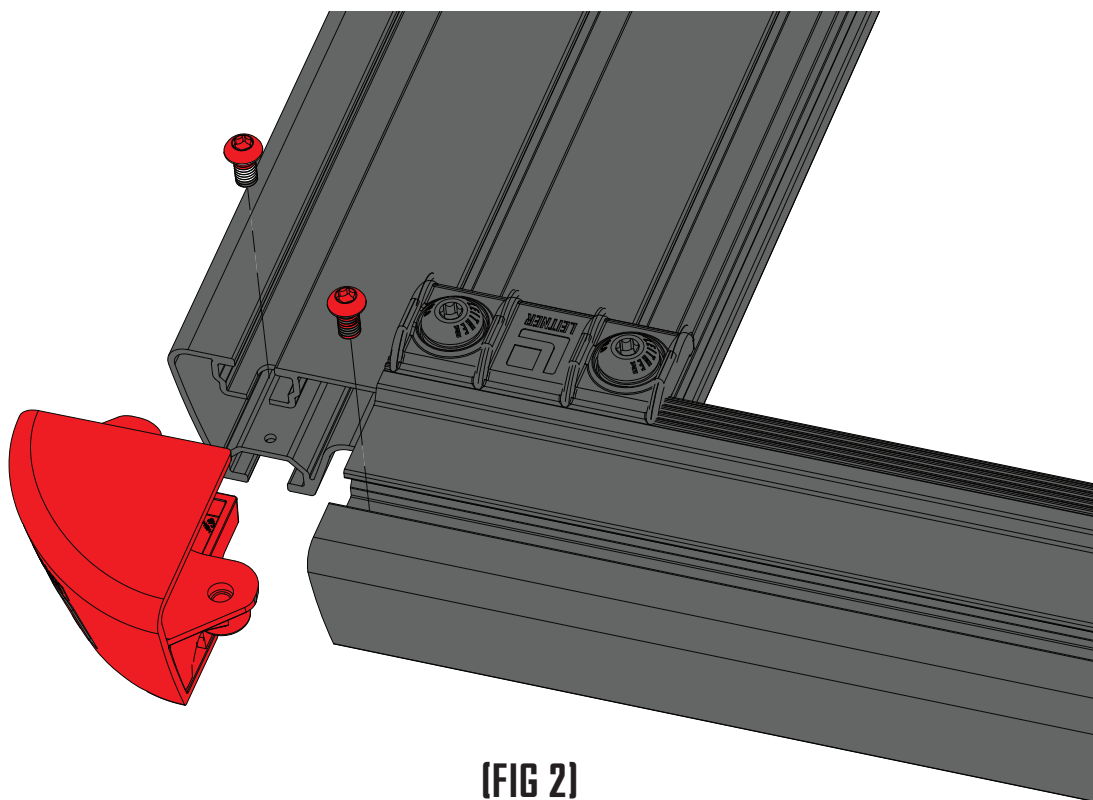

(FIG 2)

ASSEMBLE: BRACKETS

- ATTACH 1 BRACKET TO EACH CORNER USING M8 LOCKNUTS AND THE T-BOLTS INSTALLED PREVIOUSLY. **DO NOT FULLY TIGHTEN.** (FIG A)
- REPEAT FOR ALL 4 CORNERS. (FIG B)

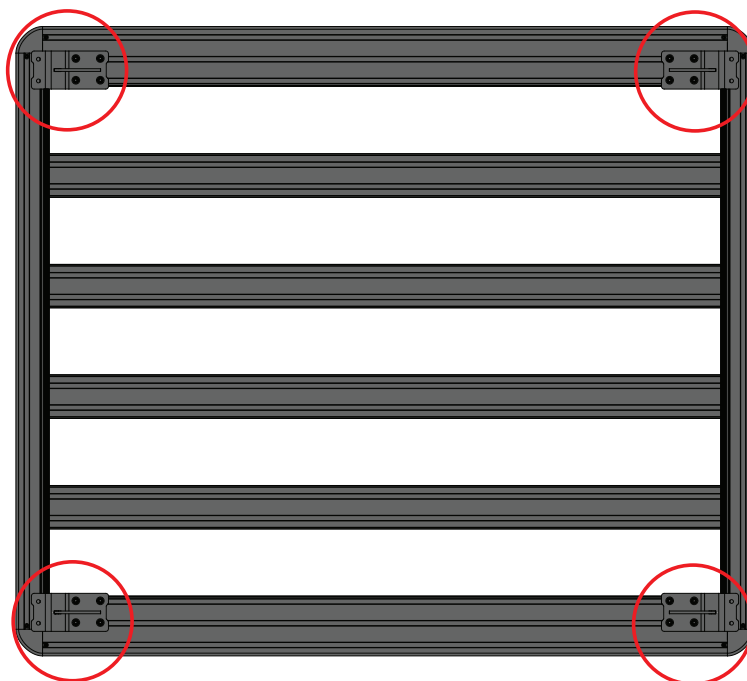
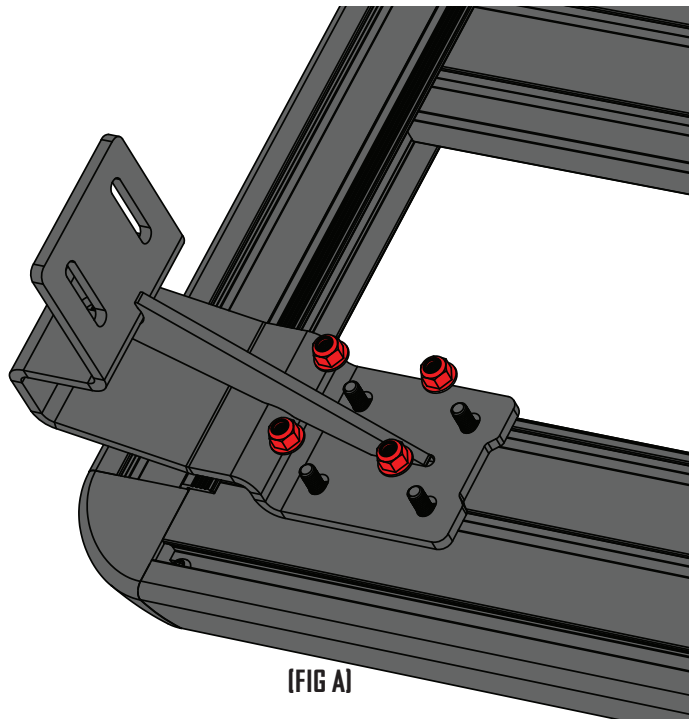

MOUNTING OPTION 1: UNIVERSAL CLAMP

- INSTALL CLAMPING PLATE HARDWARE AS SHOWN. (FIG A)
- SET RACK ONTO TRUCK BED. SLIDE CLAMP PLATE AS FAR UP AS FAR AS POSSIBLE (BEHIND TRUCK BED LIP) AND TIGHTEN BOLT AND NUT TO 16 LT-LB. (FIG B)
- TIGHTEN THE M8 LOCKNUTS THAT SECURES THE UNIVERSAL BRACKET TO THE RACK TO 16FT-LB.
- CHECK ALL HARDWARE FOR PROPER TORQUE. **YOU'RE ALL FINISHED!**

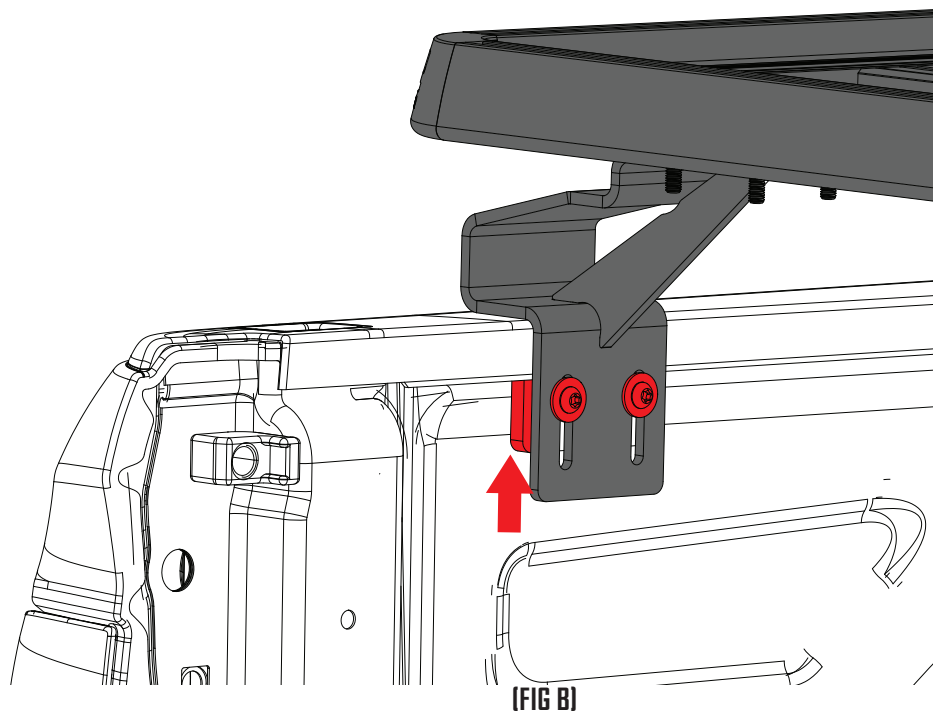
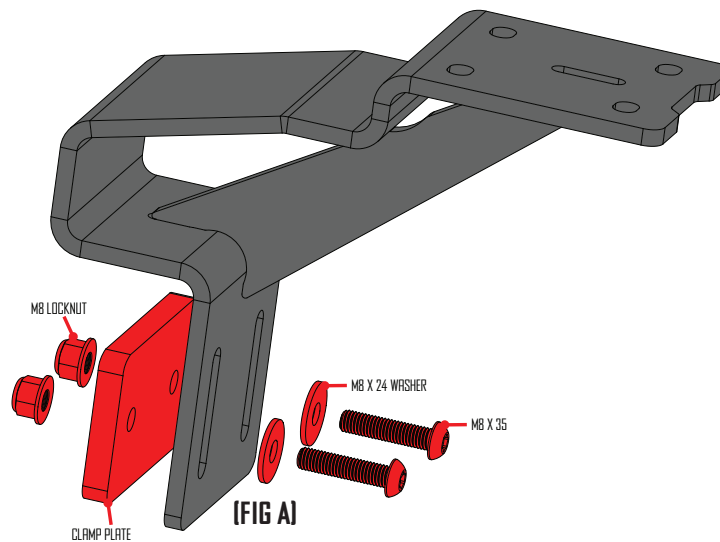

MOUNTING OPTION 2: BOLT TO RAIL

· THIS TYPE OF INSTALLATION IS FOR
05-24 TOYOTA TACOMA
2007-2024 TOYOTA TUNDRA "WITH BED RAIL"
2020-2024 JEEP GLADIATOR "WITH TRAIL RAIL"

- INSTALL FOUR **M8 X 28** T-BOLTS INTO EACH RAIL MOUNTED ON THE SIDE OF THE TRUCK.
- SECURE BRACKET USING M8 LOCKNUTS AND TIGHTEN TO 16 FT-LB
- TIGHTEN THE M8 LOCKNUTS THAT SECURES THE UNIVERSAL BRACKET TO THE RACK TO 16FT-LB.
- CHECK ALL HARDWARE FOR PROPER TORQUE. **YOU'RE ALL FINISHED!**

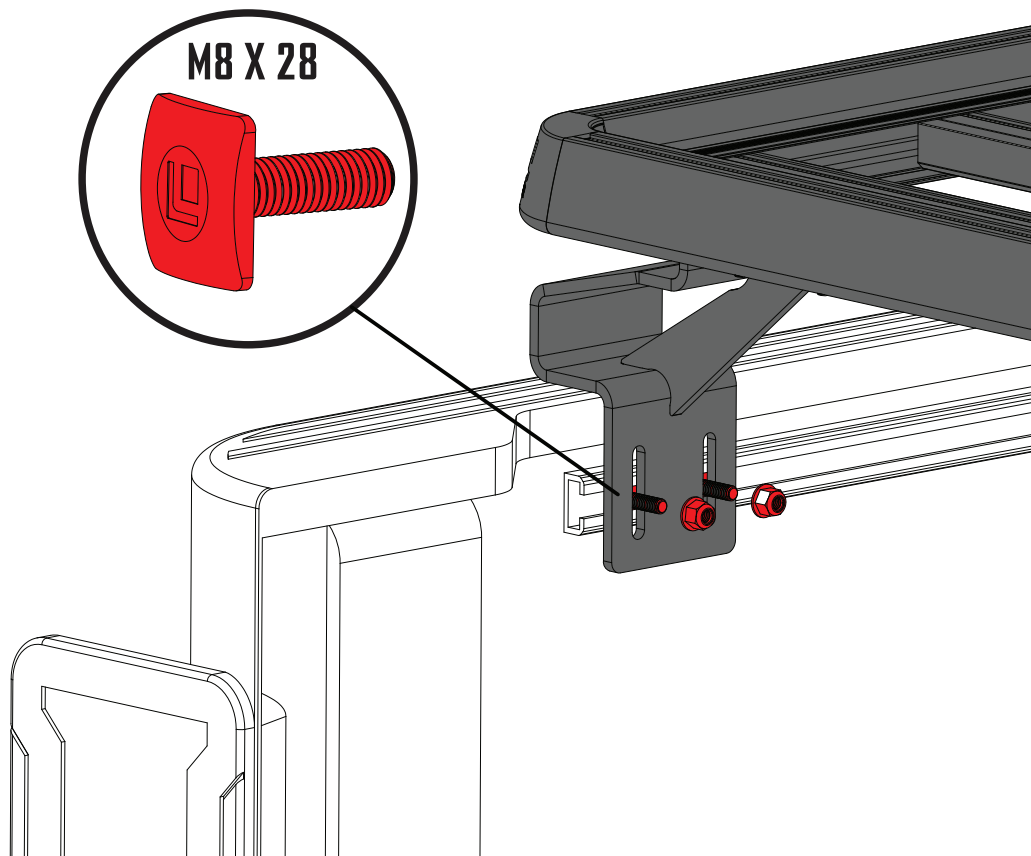

USE GUIDELINES

WHEN USING LEITNER DESIGNS CARRIERS AND ACCESSORIES, THE USER MUST UNDERSTAND THE PRECAUTIONS. THE POINTS LISTED BELOW WILL ASSIST YOU IN USING THE RACK SYSTEM AND WILL ENCOURAGE SAFETY.

-FOR QUALITY FITS AND SAFETY, USE ONLY THE RECOMMENDED RACK OR ACCESSORIES. DO NOT ASSUME A RACK WILL FIT, ALWAYS CHECK THE CURRENT FIT GUIDE WHEN OBTAINING A NEW VEHICLE.

-THE MAXIMUM LOAD IS NOT TO BE EXCEEDED. (400# OFF ROAD – 800# ON ROAD). HOWEVER, **THIS LIMIT IS ALWAYS SUBORDINATE TO THE MAXIMUM LOAD RECOMMENDED BY THE MANUFACTURER OF THE VEHICLE ITSELF.** IT IS ALWAYS THE LOWER MAXIMUM RECOMMENDED LOAD THAT APPLIES. MAX TRUCK LOAD = LOAD CARRIER WEIGHT + ANY FITTED CARRIER ACCESSORIES + THE WEIGHT OF THE LOAD ITSELF.

-HIGH SPEED OFF ROAD DRIVING EVEN WITH A LIGHT LOAD CAN CAUSE DAMAGE TO THE RACK, ACCESSORIES AND VEHICLE BODY. DAMAGE CAUSED BY HIGH SPEED DRIVING AND ABUSE IS NOT COVERED UNDER WARRANTY.

-MAKE SURE ALL KNOBS, BOLTS, SCREWS, STRAPS, AND LOCKS ARE FIRMLY ATTACHED, TIGHTENED AND LOCKED BEFORE EVERY TRIP. KNOBS, BOLTS, SCREWS, STRAPS AND LOCKS MUST BE PERIODICALLY INSPECTED FOR SIGNS OF WEAR, CORROSION, AND FATIGUE. CHECK YOUR LOAD AT STOPS DURING THE TRIP TO ENSURE CONTINUED FASTENING SECURITY.

-CHECK LOCAL AND STATE LAWS GOVERNING PROJECTION OF OBJECTS BEYOND THE PERIMETER OF A VEHICLE. BE AWARE OF THE WIDTH AND HEIGHT OF YOUR CARGO SINCE LOW CLEARANCE BRANCHES, BRIDGES, AND PARKING GARAGES CAN AFFECT THE LOAD. ALL CARGO WILL AFFECT THE VEHICLE'S DRIVING BEHAVIOR. NEVER DRIVE WITH ANY LOCK, KNOB OR RACK IN AN OPEN OR UNLOCKED POSITION. ALL LONG LOADS SUCH AS, BUT NOT LIMITED TO, SAILBOARDS, SURFBOARDS, KAYAKS, CANOES, AND LUMBER MUST BE TIED DOWN FRONT AND REAR TO THE BUMPERS OR TOW HOOKS OF THE VEHICLE.

-ALL LOCKS MUST BE TURNED AND MOVED PERIODICALLY TO ENSURE SMOOTH OPERATION. USE GRAPHITE OR DRY LUBRICANT TO HELP THIS. LEITNER DESIGNS LOCKS ARE DESIGNED TO DETER VANDALISM AND THEFT BUT SHOULD NOT BE CONSIDERED THEFT PROOF. REMOVE VALUABLE GEAR IF YOUR VEHICLE IS UNATTENDED FOR AN EXTENDED PERIOD. PLACE AT LEAST ONE KEY IN THE GLOVE COMPARTMENT.

-FOR SAFETY TO YOUR VEHICLE AND RACK SYSTEM, OBEY ALL POSTED SPEED LIMITS AND TRAFFIC CAUTIONS. ADAPT YOUR SPEED TO THE CONDITIONS OF THE ROAD AND THE LOAD BEING CARRIED.

-DO NOT USE LEITNER DESIGNS LOAD CARRIERS AND ACCESSORIES FOR PURPOSES OTHER THAN THOSE FOR WHICH THEY WERE DESIGNED. DO NOT EXCEED THEIR CARRYING CAPACITY. FAILURE TO FOLLOW THESE GUIDELINES OR THE PRODUCT'S INSTRUCTIONS WILL VOID THE WARRANTY.

WARRANTY

LEITNER DESIGNS WARRANTS PRODUCT TO BE FREE FROM DEFECTS IN MATERIAL AND WORKMANSHIP, FOR TERMS SPECIFIED BELOW, PROVIDED THERE HAS BEEN NORMAL USE AND PROPER MAINTENANCE. ALL REMEDIES UNDER THIS WARRANTY ARE LIMITED TO THE REPAIR OR REPLACEMENT OF ANY ITEM FOUND BY THE FACTORY TO BE DEFECTIVE WITHIN THE TIME PERIOD SPECIFIED. IF YOU HAVE A WARRANTY CLAIM, FIRST YOU MUST CALL OUR FACTORY AT THE NUMBER BELOW FOR INSTRUCTIONS. YOU MUST RETAIN PROOF OF PURCHASE AND SUBMIT A COPY WITH ANY ITEMS RETURNED FOR WARRANTY WORK. UPON COMPLETION OF WARRANTY WORK, IF ANY, WE WILL RETURN THE REPAIRED OR REPLACED ITEM OR ITEMS TO YOU FREIGHT PREPAID. DAMAGE TO OUR PRODUCTS CAUSED BY ACCIDENTS, FIRE, VANDALISM, NEGLIGENCE, MIS-INSTALLATION, MISUSE, ACTS OF GOD, OR BY DEFECTIVE PARTS NOT MANUFACTURED BY US, IS NOT COVERED UNDER THIS WARRANTY.

THE WARRANTY TIME PERIOD IS AS FOLLOWS: (2) TWO YEARS FROM DATE OF PURCHASE.

HIGH SPEED OFF ROAD DRIVING EVEN WITH A LIGHT LOAD CAN CAUSE DAMAGE TO THE RACK, ACCESSORIES AND VEHICLE BODY. DAMAGE CAUSED BY HIGH SPEED OFF ROAD DRIVING AND ABUSE IS NOT COVERED UNDER WARRANTY.

ANY IMPLIED WARRANTIES OF MERCHANTABILITY AND/OR FITNESS FOR A PARTICULAR PURPOSE CREATED HEREBY ARE LIMITED IN DURATION TO THE SAME DURATION AND SCOPE AS THE EXPRESS WRITTEN WARRANTY. OUR COMPANY SHALL NOT BE LIABLE FOR ANY INCIDENTAL OR CONSEQUENTIAL DAMAGE.

SOME STATES DO NOT ALLOW LIMITATIONS ON HOW LONG AN IMPLIED WARRANTY LASTS, OR THE EXCLUSION OR LIMITATION OF INCIDENTAL OR CONSEQUENTIAL DAMAGES, SO THE ABOVE LIMITATIONS OR EXCLUSIONS MAY NOT APPLY TO YOU. THIS WARRANTY GIVES YOU SPECIFIC LEGAL RIGHTS, AND YOU MAY ALSO HAVE OTHER RIGHTS THAT VARY FROM STATE TO STATE.

FOR WARRANTY ISSUES WITH THIS PRODUCT PLEASE CALL LEITNER DESIGNS CUSTOMER SERVICE **949-395-3049** OR EMAIL US AT **SALES@LEITNERDESIGNS.COM**