

# LEITNER

---

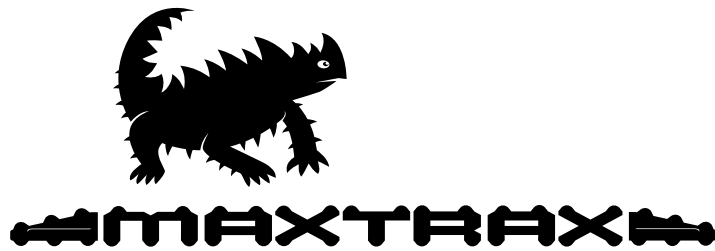
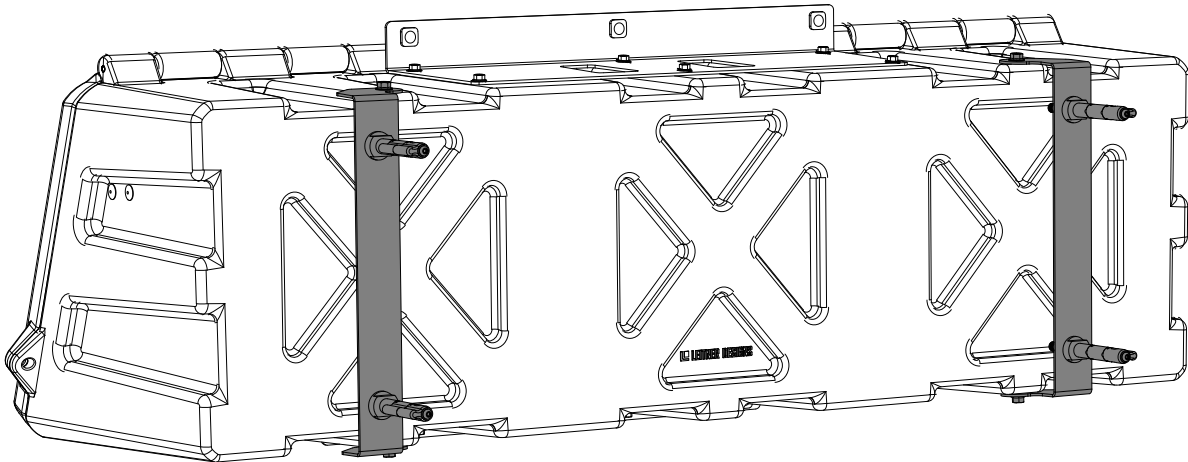

MAXTRAX APPROVED ACCESSORY

## GEAR POD XL-MAXTRAX BRACKETS

LEITNERDESIGNS.COM | SUPPORT@LEITNERDESIGNS.COM | 949-395-3049

# ASSEMBLY / INSTALLATION INSTRUCTIONS:

## PART NUMBER:

00-XLMAX-01-1297

## TOOLS REQUIRED

- 12MM WRENCH
- 13MM WRENCH
- 17MM WRENCH
- 21MM WRENCH
- ELECTRIC DRILL
- 9/32 DRILL BIT

## INSTALLATION TIME

25-30 MINUTES

BASIC KNOWLEDGE OF HAND TOOLS REQUIRED

## SKILL LEVEL

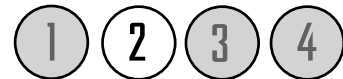

2= NOVICE

## ▼ GEAR POD XL - MAXTRAX HARDWARE ▼

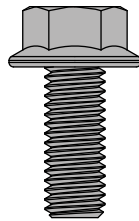

M8 X 20  
(X4)

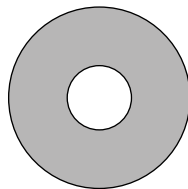

M8 WASHER  
(X4)

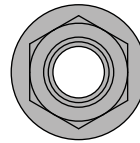

M8 NUT  
(X4)

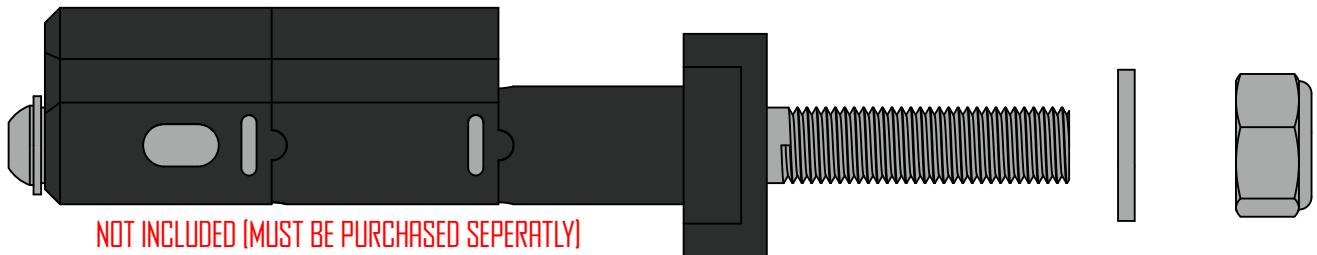

MAXTRAX MOUNTING PIN  
(X4)

LEITNERDESIGNS.COM | SUPPORT@LEITNERDESIGNS.COM | 949-395-3049

## ▼ READ BEFORE INSTALLING ▼

1. DON'T OVER-TIGHTEN BOLTS. ALL 8MM BOLTS = (10 FT-LB)
3. LAY DOWN A LARGE AREA OF CARPET OR BLANKETS AS A WORK AREA TO AVOID SCRATCHING PARTS DURING ASSEMBLY.
5. TAKE YOUR TIME TO DO IT RIGHT.
6. ALTHOUGH THE GEAR POD XL IS LIGHT HAVING A FRIEND TO HELP DURING INSTALL IS RECOMMENDED.

## ▼ ASSEMBLY OVERVIEW ▼

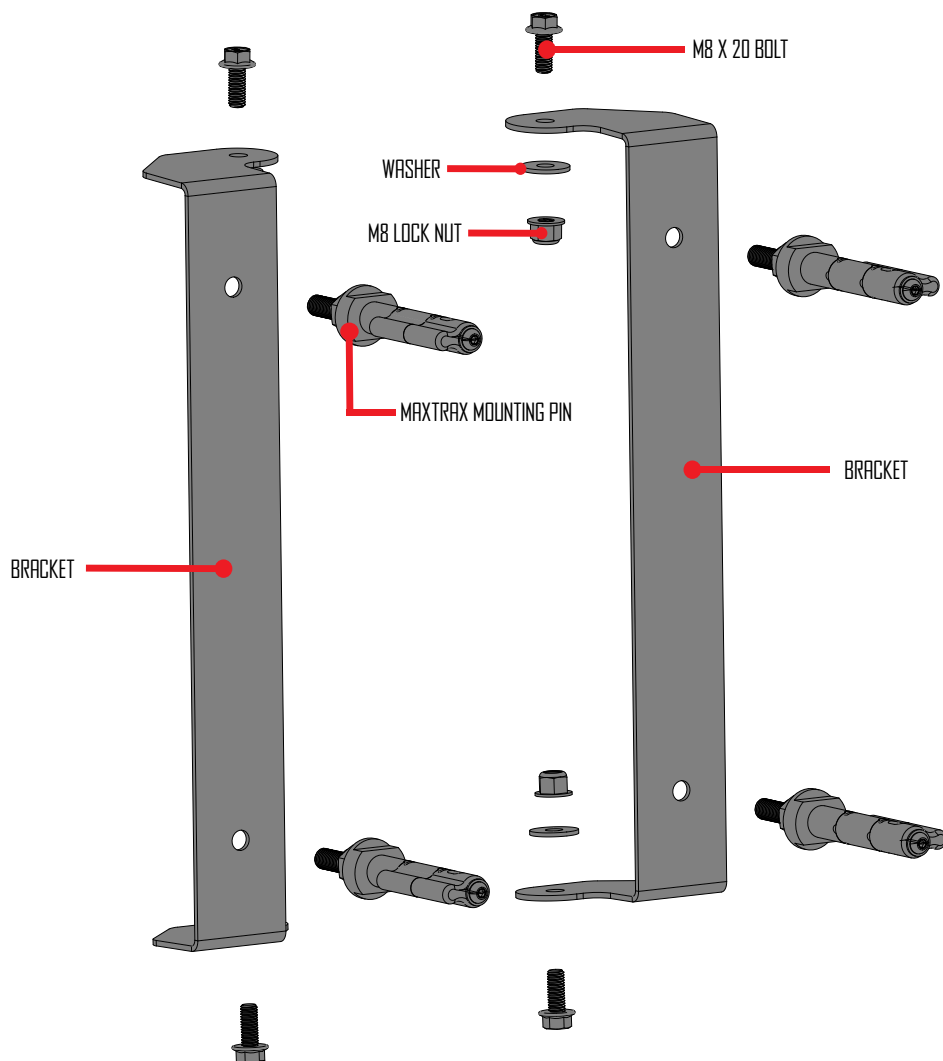

# ATTACH PINS TO BRACKET: TIGHTEN MID NUTS

- PINS NOT INCLUDED WITH KIT.

- ATTACH A PIN AS SHOWN TO EACH OF THE FOUR HOLES IN THE BRACKETS USING THE SUPPLIED WASHERS AND MID LOCK NUT.

- ENSURE THE PINS ARE ORIENTATED CORRECTLY AS SHOWN WITH THE LOCKING LOBE FACING OUT.

- TIGHTEN THE MID NUT USING A 17MM WRENCH WHILE HOLDING THE FLATS ON THE PIN WITH A 21MM WRENCH.

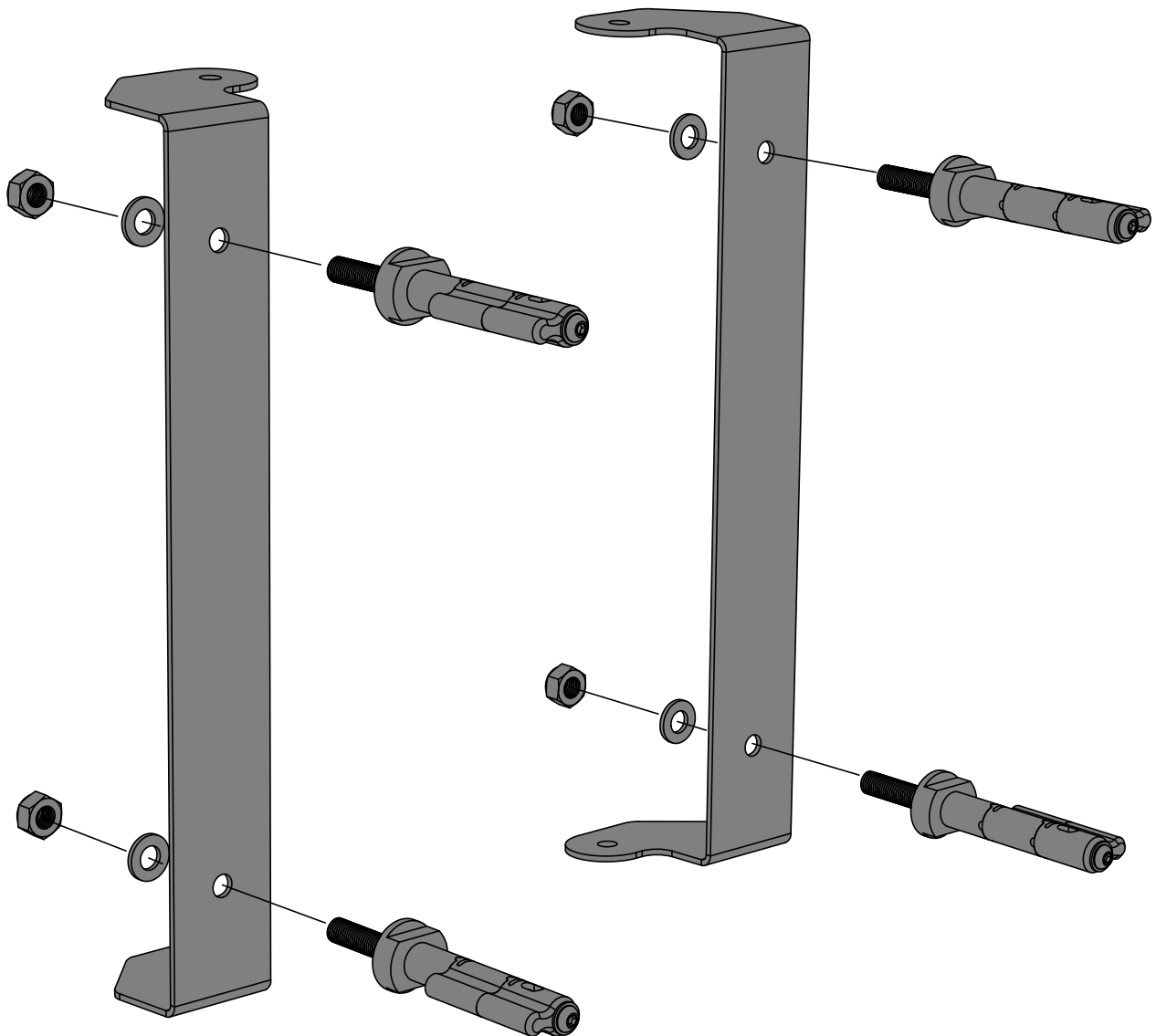

## OPTIONAL: SHORTEN MOUNTING PIN STUDS

- THE THREADED STUDS ON THE MOUNTING PINS CAN BE CUT DOWN FLUSH WITH THE LOCKNUT IF DESIRED. THIS WILL BRING THE MAXTRAX CLOSER TO THE BACK OF THE GEARPOD AND CREATE A CLEANER LOOK WHILE ALSO FREEING UP SOME SPACE ON THE INSIDE OF THE TRUCK BED.
- A HACKSAW OR CUTOFF WHEEL WORKS BEST TO CUT THE THREADED STUD. **(USE EYE PROTECTION)**
- **THE BRACKETS WILL FUNCTION PERFECTLY FINE WITHOUT THIS STEP.**

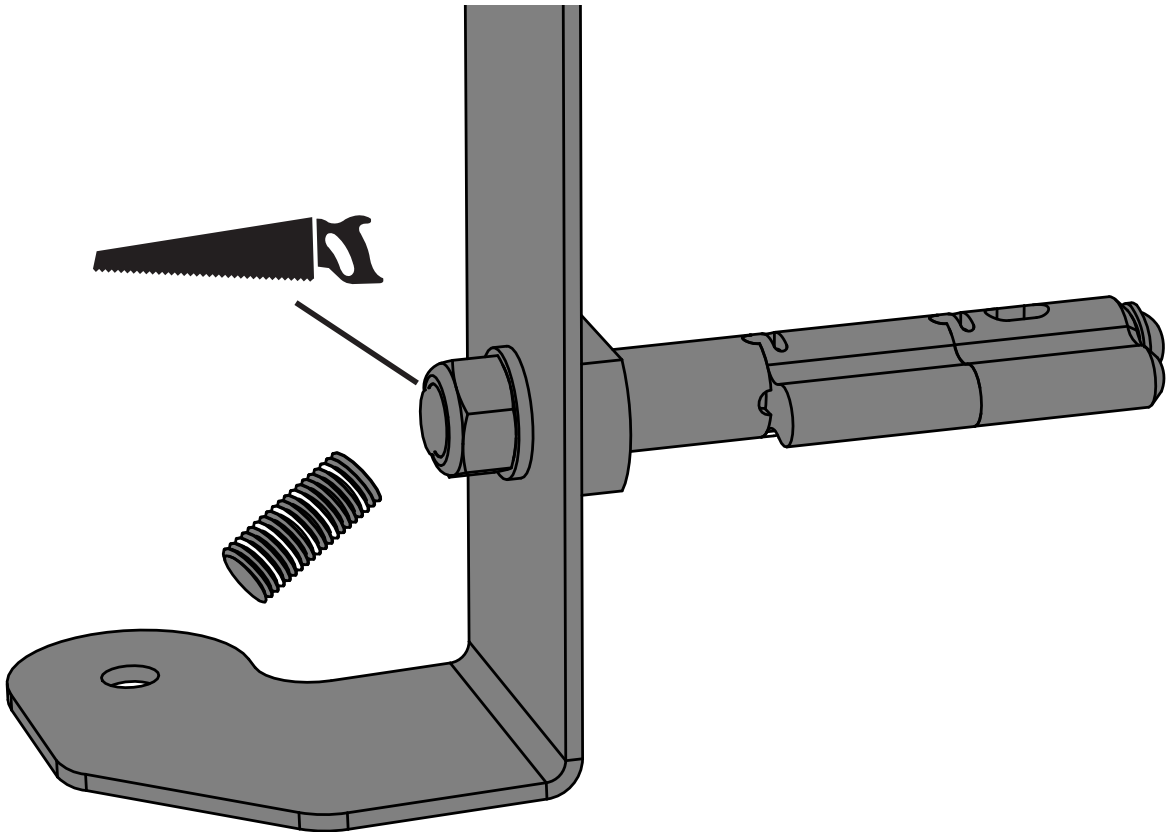

# INSTALL: ATTACH BRACKETS TO MAXTRAX

- ALIGN THE MOUNTING PINS WITH THE KEYED SLOTS IN THE MAXTRAX
- TWIST THE PINS BY 90 DEGREES INTO THERE LOCKED POSITION.
- **NOTE : THE LEGS OF THE BRACKETS MUST BE FACING EACH OTHER AS SHOWN IN THE ILLUSTRATION.**

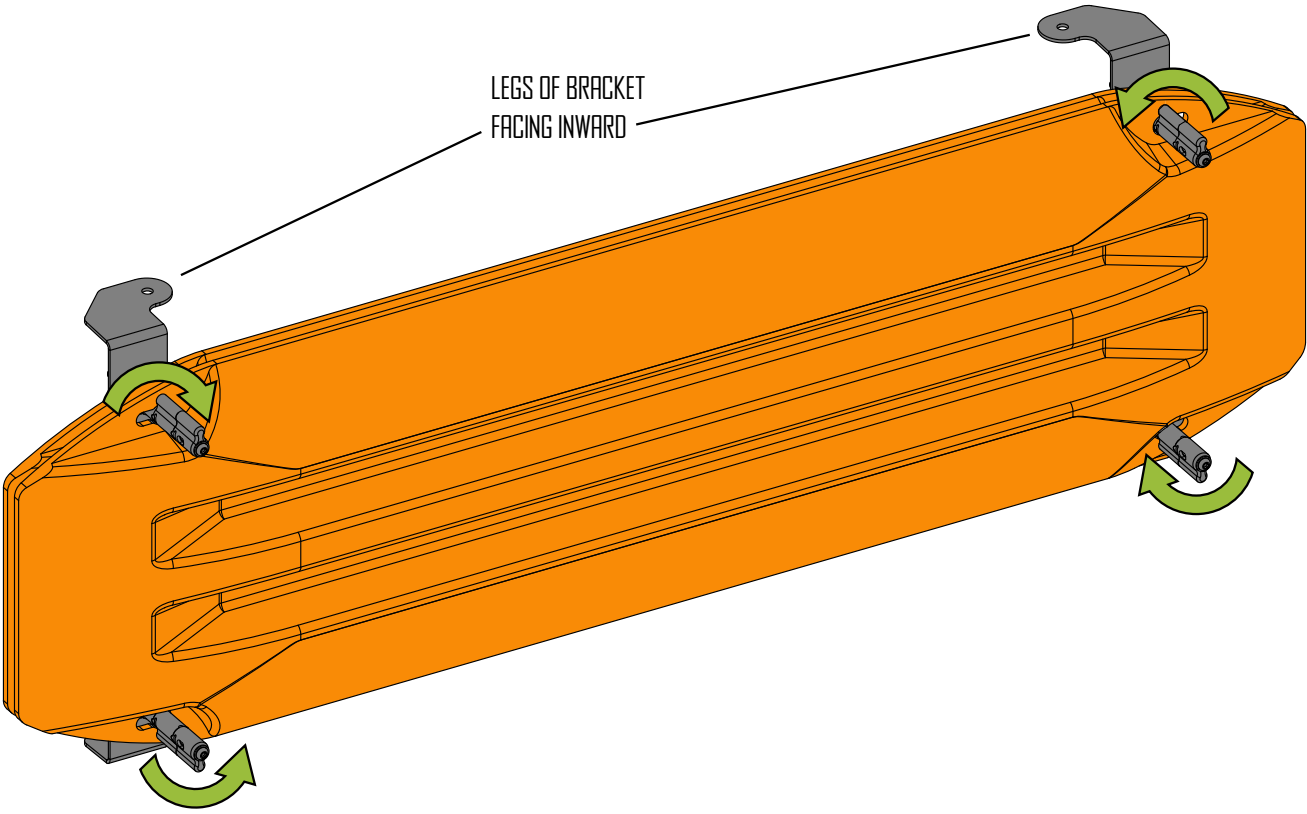

# DRILL: DRILL MOUNTING HOLES

- SET THE GEARPOD XL ONTO A FLAT SOFT SURFACE LID DOWN.
- PLACE THE BRACKETS WITH MAXTRAX ON THE BACK OF THE POD MAKING SURE THE HOLES IN THE BRACKET ARE ON THE HIGH PART OF THE GEAR POD.
- MAKE SURE THE MOUNTS ARE TOUCHING THE BACK OF THE POD. (THE STUDS OF THE MAXTRAX MOUNTS WILL HIT FIRST)
- USING THE HOLES IN THE BRACKETS AS A GUIDE DRILL ALL 4 HOLES USING A 9/32" DRILL.

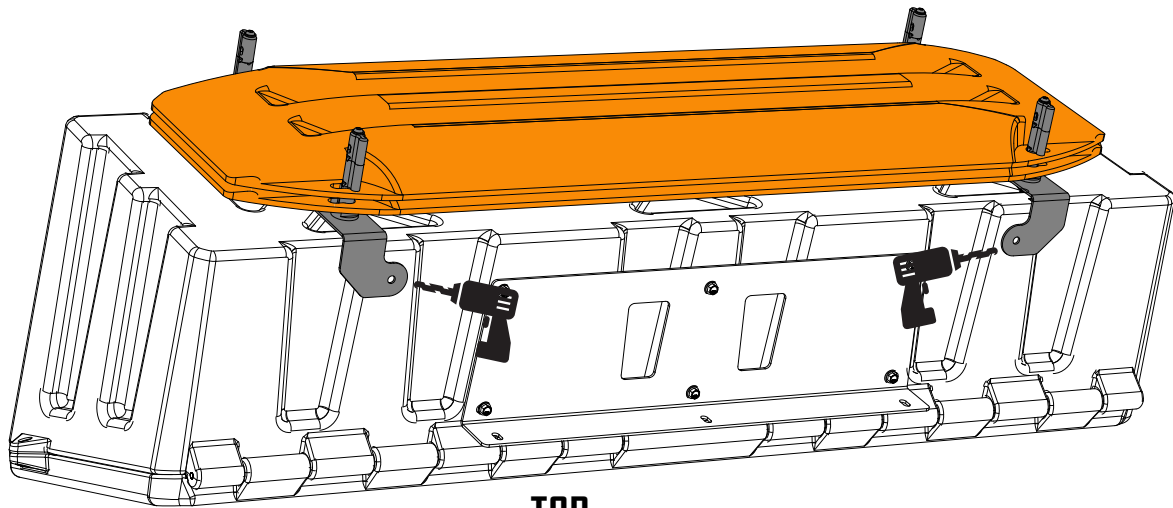

**TOP**

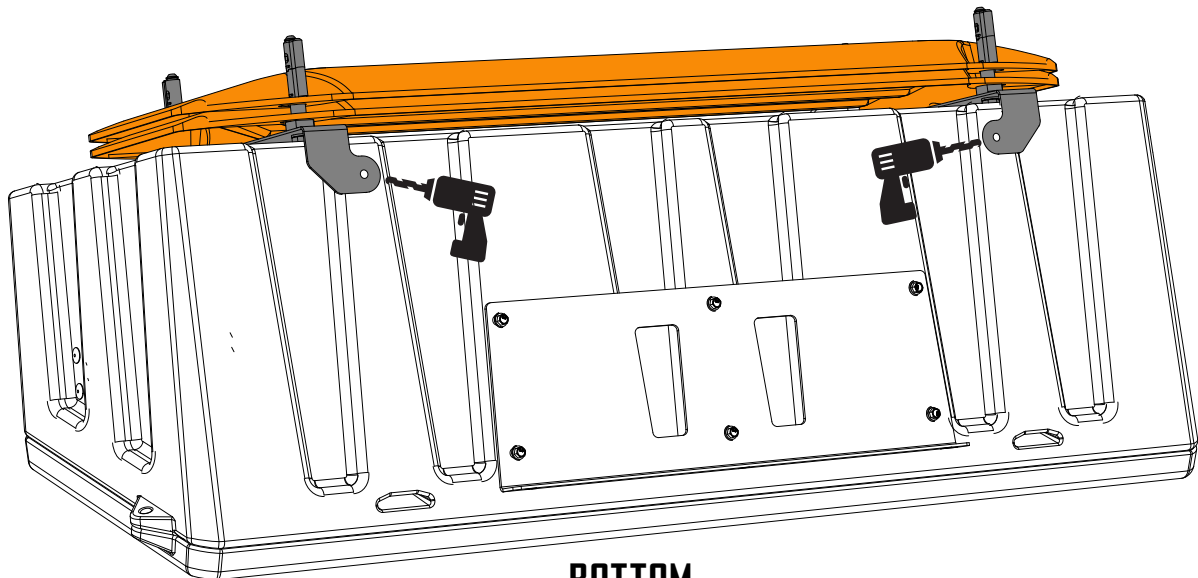

**BOTTOM**

# ATTACH: INSTALL AND TIGHTEN FASTENERS

- INSTALL M8X20 BOLT THROUGH THE BRACKET AND THE HOLE YOU DRILLED IN THE LAST STEP. NOTE: THE TIGHT FIT IS NORMAL AND WILL PREVENT WATER INTRUSION. SPINNING THE FASTENER WILL HELP WITH INSTALLATION.
- USING A WASHER AND A NUT FROM THE INSIDE TIGHTEN EACH NUT TO 10FT-LB

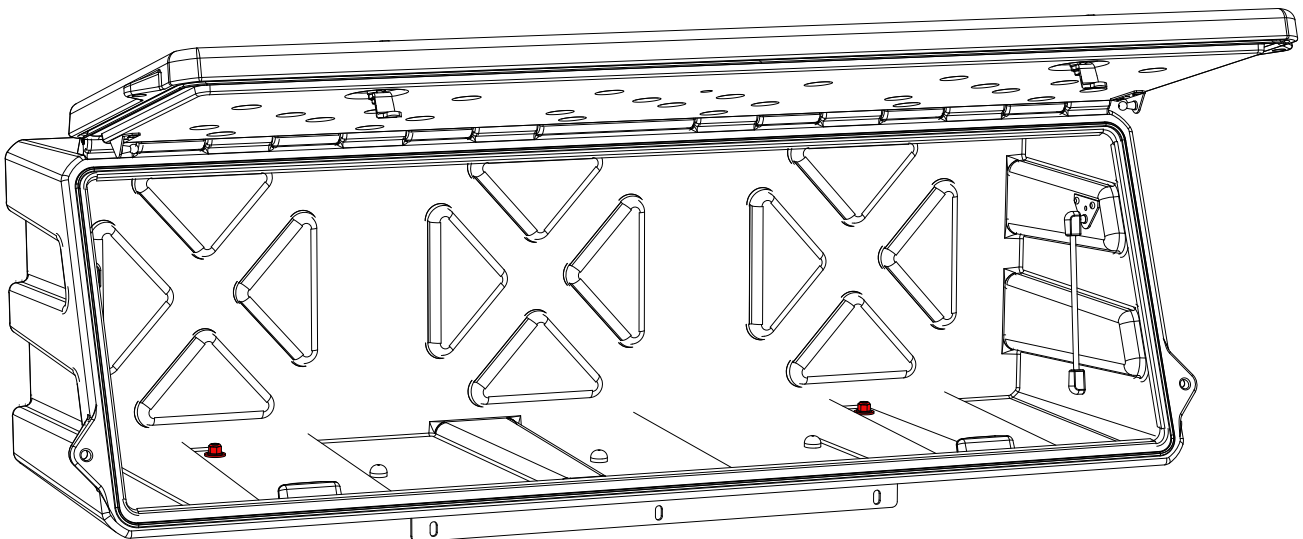
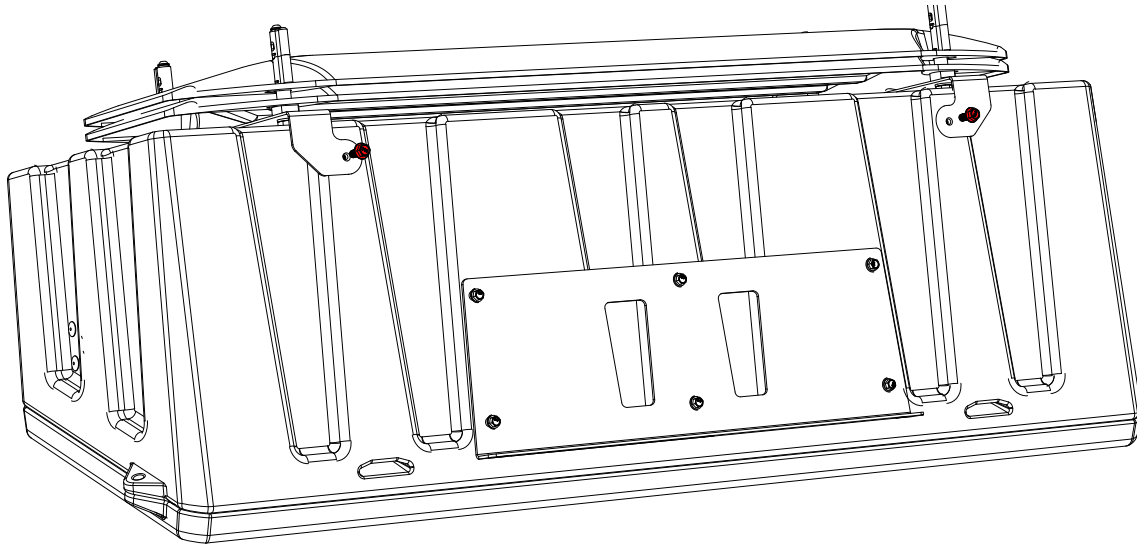



# USE GUIDELINES

WHEN USING LEITNER DESIGNS CARRIERS AND ACCESSORIES, THE USER MUST UNDERSTAND THE PRECAUTIONS. THE POINTS LISTED BELOW WILL ASSIST YOU IN USING THE RACK SYSTEM AND WILL ENCOURAGE SAFETY.

-FOR QUALITY FITS AND SAFETY, USE ONLY THE RECOMMENDED RACK OR ACCESSORIES. DO NOT ASSUME A RACK WILL FIT, ALWAYS CHECK THE CURRENT FIT GUIDE WHEN OBTAINING A NEW VEHICLE.

-THE MAXIMUM LOAD IS NOT TO BE EXCEEDED. (250# OFF ROAD – 500# ON ROAD). HOWEVER, THIS LIMIT IS ALWAYS SUBORDINATE TO THE MAXIMUM LOAD RECOMMENDED BY THE MANUFACTURER OF THE VEHICLE ITSELF. IT IS ALWAYS THE LOWER MAXIMUM RECOMMENDED LOAD THAT APPLIES. MAX TRUCK LOAD = LOAD CARRIER WEIGHT + ANY FITTED CARRIER ACCESSORIES + THE WEIGHT OF THE LOAD ITSELF.

**-HIGH SPEED OFF ROAD DRIVING EVEN WITH A LIGHT LOAD CAN CAUSE DAMAGE TO THE RACK, ACCESSORIES AND VEHICLE BODY. DAMAGE CAUSED BY HIGH SPEED DRIVING AND ABUSE IS NOT COVERED UNDER WARRANTY.**

-MAKE SURE ALL KNOBS, BOLTS, SCREWS, STRAPS, AND LOCKS ARE FIRMLY ATTACHED, TIGHTENED AND LOCKED BEFORE EVERY TRIP. KNOBS, BOLTS, SCREWS, STRAPS AND LOCKS MUST BE PERIODICALLY INSPECTED FOR SIGNS OF WEAR, CORROSION, AND FATIGUE. CHECK YOUR LOAD AT STOPS DURING THE TRIP TO ENSURE CONTINUED FASTENING SECURITY.

-CHECK LOCAL AND STATE LAWS GOVERNING PROJECTION OF OBJECTS BEYOND THE PERIMETER OF A VEHICLE. BE AWARE OF THE WIDTH AND HEIGHT OF YOUR CARGO SINCE LOW CLEARANCE BRANCHES, BRIDGES, AND PARKING GARAGES CAN AFFECT THE LOAD. ALL CARGO WILL AFFECT THE VEHICLE'S DRIVING BEHAVIOR. NEVER DRIVE WITH ANY LOCK, KNOB OR RACK IN AN OPEN OR UNLOCKED POSITION. ALL LONG LOADS SUCH AS, BUT NOT LIMITED TO, SAILBOARDS, SURFBOARDS, KAYAKS, CANOES, AND LUMBER MUST BE TIED DOWN FRONT AND REAR TO THE BUMPERS OR TOW HOOKS OF THE VEHICLE.

-ALL LOCKS MUST BE TURNED AND MOVED PERIODICALLY TO ENSURE SMOOTH OPERATION. USE GRAPHITE OR DRY LUBRICANT TO HELP THIS. LEITNER DESIGNS LOCKS ARE DESIGNED TO DETER VANDALISM AND THEFT BUT SHOULD NOT BE CONSIDERED THEFT PROOF. REMOVE VALUABLE GEAR IF YOUR VEHICLE IS UNATTENDED FOR AN EXTENDED PERIOD. PLACE AT LEAST ONE KEY IN THE GLOVE COMPARTMENT.

-FOR SAFETY TO YOUR VEHICLE AND RACK SYSTEM, OBEY ALL POSTED SPEED LIMITS AND TRAFFIC CAUTIONS. ADAPT YOUR SPEED TO THE CONDITIONS OF THE ROAD AND THE LOAD BEING CARRIED.

-DO NOT USE LEITNER DESIGNS LOAD CARRIERS AND ACCESSORIES FOR PURPOSES OTHER THAN THOSE FOR WHICH THEY WERE DESIGNED. DO NOT EXCEED THEIR CARRYING CAPACITY. FAILURE TO FOLLOW THESE GUIDELINES OR THE PRODUCT'S INSTRUCTIONS WILL VOID THE WARRANTY.

# WARRANTY

LEITNER DESIGNS WARRANTS PRODUCT TO BE FREE FROM DEFECTS IN MATERIAL AND WORKMANSHIP, FOR TERMS SPECIFIED BELOW, PROVIDED THERE HAS BEEN NORMAL USE AND PROPER MAINTENANCE. ALL REMEDIES UNDER THIS WARRANTY ARE LIMITED TO THE REPAIR OR REPLACEMENT OF ANY ITEM FOUND BY THE FACTORY TO BE DEFECTIVE WITHIN THE TIME PERIOD SPECIFIED. IF YOU HAVE A WARRANTY CLAIM, FIRST YOU MUST CALL OUR FACTORY AT THE NUMBER BELOW FOR INSTRUCTIONS. YOU MUST RETAIN PROOF OF PURCHASE AND SUBMIT A COPY WITH ANY ITEMS RETURNED FOR WARRANTY WORK. UPON COMPLETION OF WARRANTY WORK, IF ANY, WE WILL RETURN THE REPAIRED OR REPLACED ITEM OR ITEMS TO YOU FREIGHT PREPAID. DAMAGE TO OUR PRODUCTS CAUSED BY ACCIDENTS, FIRE, VANDALISM, NEGLIGENCE, MIS-INSTALLATION, MISUSE, ACTS OF GOD, OR BY DEFECTIVE PARTS NOT MANUFACTURED BY US, IS NOT COVERED UNDER THIS WARRANTY.

THE WARRANTY TIME PERIOD IS AS FOLLOWS: (2) TWO YEARS FROM DATE OF PURCHASE.

**HIGH SPEED OFF ROAD DRIVING EVEN WITH A LIGHT LOAD CAN CAUSE DAMAGE TO THE RACK, ACCESSORIES AND VEHICLE BODY. DAMAGE CAUSED BY HIGH SPEED OFF ROAD DRIVING AND ABUSE IS NOT COVERED UNDER WARRANTY.**

GEAR PODS ARE WATER RESISTANT AND NOT WATERPROOF. ITEMS THAT CAN BE DAMAGED BY WATER SHOULD BE STORED INSIDE THEIR OWN AIR TIGHT CONTAINER BEFORE BEING PLACED IN THE GEAR POD.

ANY IMPLIED WARRANTIES OF MERCHANTABILITY AND/OR FITNESS FOR A PARTICULAR PURPOSE CREATED HEREBY ARE LIMITED IN DURATION TO THE SAME DURATION AND SCOPE AS THE EXPRESS WRITTEN WARRANTY. OUR COMPANY SHALL NOT BE LIABLE FOR ANY INCIDENTAL OR CONSEQUENTIAL DAMAGE.

SOME STATES DO NOT ALLOW LIMITATIONS ON HOW LONG AN IMPLIED WARRANTY LASTS, OR THE EXCLUSION OR LIMITATION OF INCIDENTAL OR CONSEQUENTIAL DAMAGES, SO THE ABOVE LIMITATIONS OR EXCLUSIONS MAY NOT APPLY TO YOU. THIS WARRANTY GIVES YOU SPECIFIC LEGAL RIGHTS, AND YOU MAY ALSO HAVE OTHER RIGHTS THAT VARY FROM STATE TO STATE.

FOR WARRANTY ISSUES WITH THIS PRODUCT PLEASE CALL LEITNER DESIGNS CUSTOMER SERVICE **949-395-3049** OR EMAIL US AT **SUPPORT@LEITNERDESIGNS.COM**