

GEAR POD GEN 2

LEITNERDESIGNS.COM | SUPPORT@LEITNERDESIGNS.COM | 949-395-3049

ASSEMBLY / INSTALLATION INSTRUCTIONS:

PART NUMBER:

00-GPG2-1423

TOOLS REQUIRED

- TORQUE WRENCH
- T30 TORX
- T40 TORX

INSTALLATION TIME

10-15 MINUTES

BASIC KNOWLEDGE OF HAND TOOLS REQUIRED

SKILL LEVEL

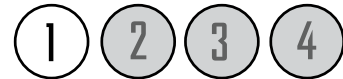

1= EASY

▼ GEAR POD HARDWARE ▼

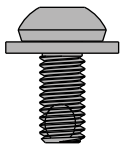

M6 X 12
(X6)

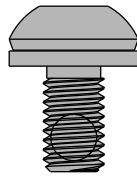

M8 X 14
(X4)

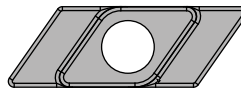

TRAKLOK NUT
(X4)

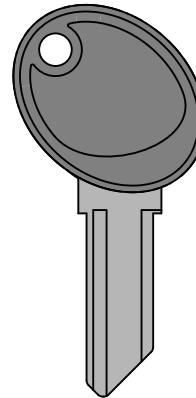

KEY
(X2)

PLEASE MAKE NOTE OF YOUR
KEY NUMBER BELOW SO WE CAN
REPLACE IT IF LOST

KEY NUMBER

▼ READ BEFORE INSTALLING GEAR POD ▼

1. DON'T OVER-TIGHTEN BOLTS. ALL 6MM BOLTS = 5 FT-LB) ALL 8MM BOLTS = (14 FT-LB)
2. LAY DOWN A LARGE AREA OF CARPET OR BLANKETS AS A WORK AREA TO AVOID SCRATCHING PARTS DURING ASSEMBLY.
3. TAKE YOUR TIME TO DO IT RIGHT.

EVERY EFFORT HAS BEEN MADE TO MAKE THE GEAR POD AS WATER TIGHT AS POSSIBLE. HOWEVER DUE TO MANUFACTURING TOLERANCE, DRIVING CONDITIONS AND WEATHER, WE DO NOT RECOMMEND STORING ITEMS THAT CAN BE DAMAGED BY WATER BEFORE PLACING THEM IN THERE OWN AIRTIGHT CONTAINER.

THE GEAR POD NOR ITS CONTENTS ARE WARRANTIED AGAINST WATER INTRUSION

▼ ASSEMBLY OVERVIEW ▼

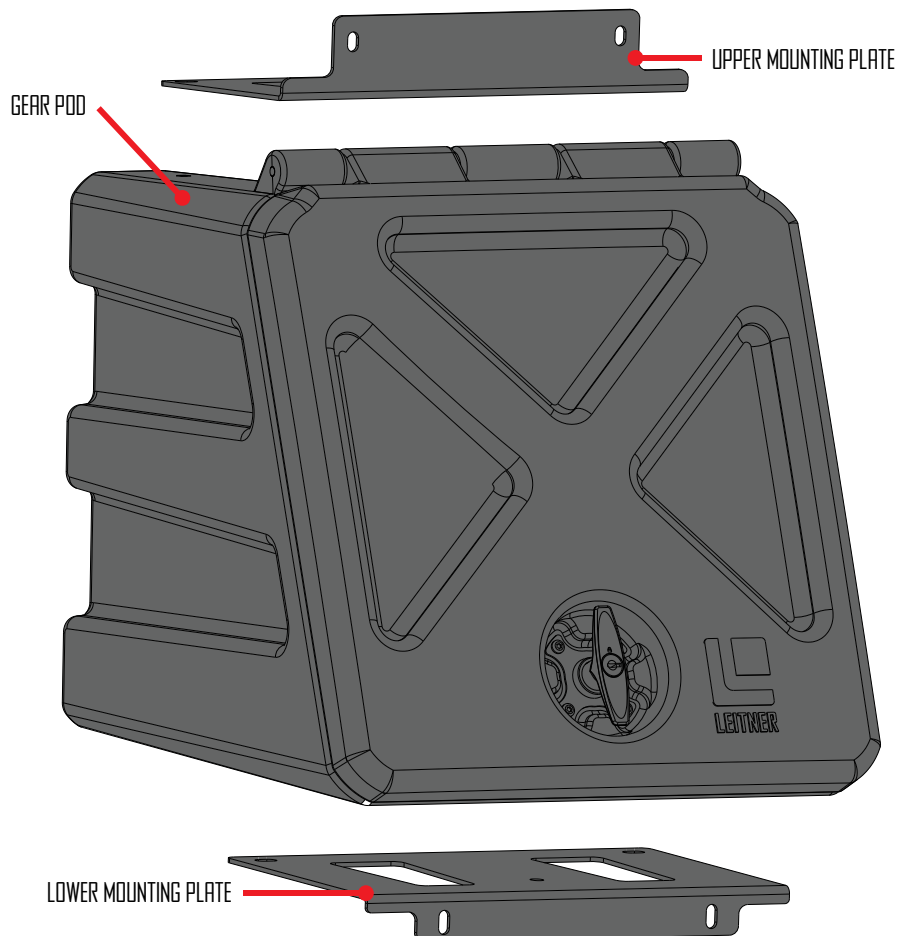

ATTACH UPPER MOUNTING PLATE: INSTALL M6 BOLTS

- PLACE THE UPPER MOUNTING PLATE ON TOP OF THE BOX. **(THE UPPER MOUNTING PLATE HAS THE LONGER MOUNTING FLANGE)**
- ENSURE THE MOUNTING FLANGE FACES THE FRONT OF THE BOX.
- ALIGN THE THREE HOLES IN THE MOUNTING PLATE WITH THE BRASS INSERT IN THE GEAR POD.
- START ONE THREAD ON EACH BOLT FIRST. (LIFTING THE PLATE TO GET THE CORNER SCREW STARTED MAKES THIS EASIER).
- TIGHTEN THE SCREWS USING A T30 TORX WRENCH

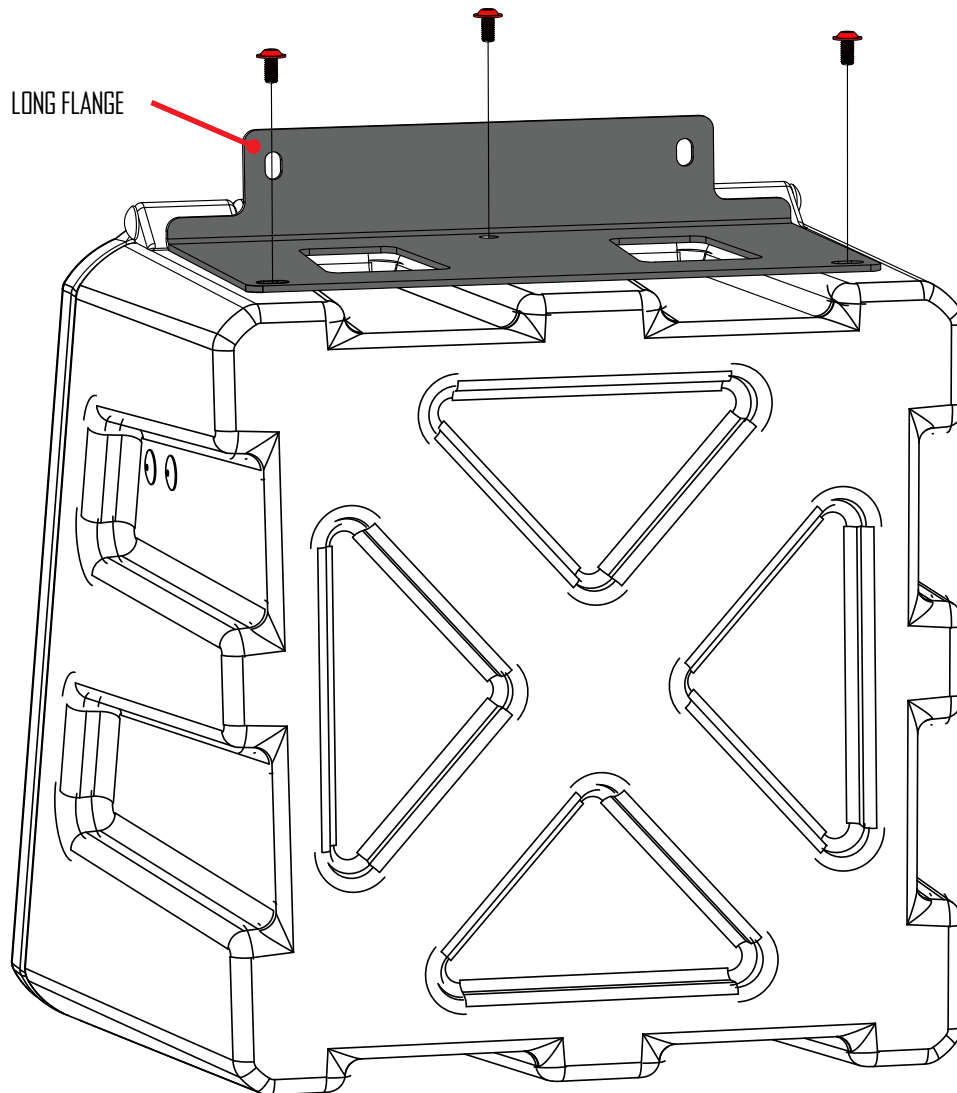

ATTACH LOWER MOUNTING PLATE: INSTALL M6 BOLTS

- PLACE THE LOWER MOUNTING PLATE ON TOP OF THE BOX. **(THE LOWER MOUNTING PLATE HAS THE SHORTER MOUNTING FLANGE)**
- ENSURE THE MOUNTING FLANGE FACES THE FRONT OF THE BOX.
- ALIGN THE THREE HOLES IN THE MOUNTING PLATE WITH THE BRASS INSERT IN THE GEAR POD.
- START ONE THREAD ON EACH BOLT FIRST. (LIFTING THE PLATE TO GET THE CORNER SCREW STARTED MAKES THIS EASIER).
- TIGHTEN THE SCREWS USING A T30 TORX WRENCH

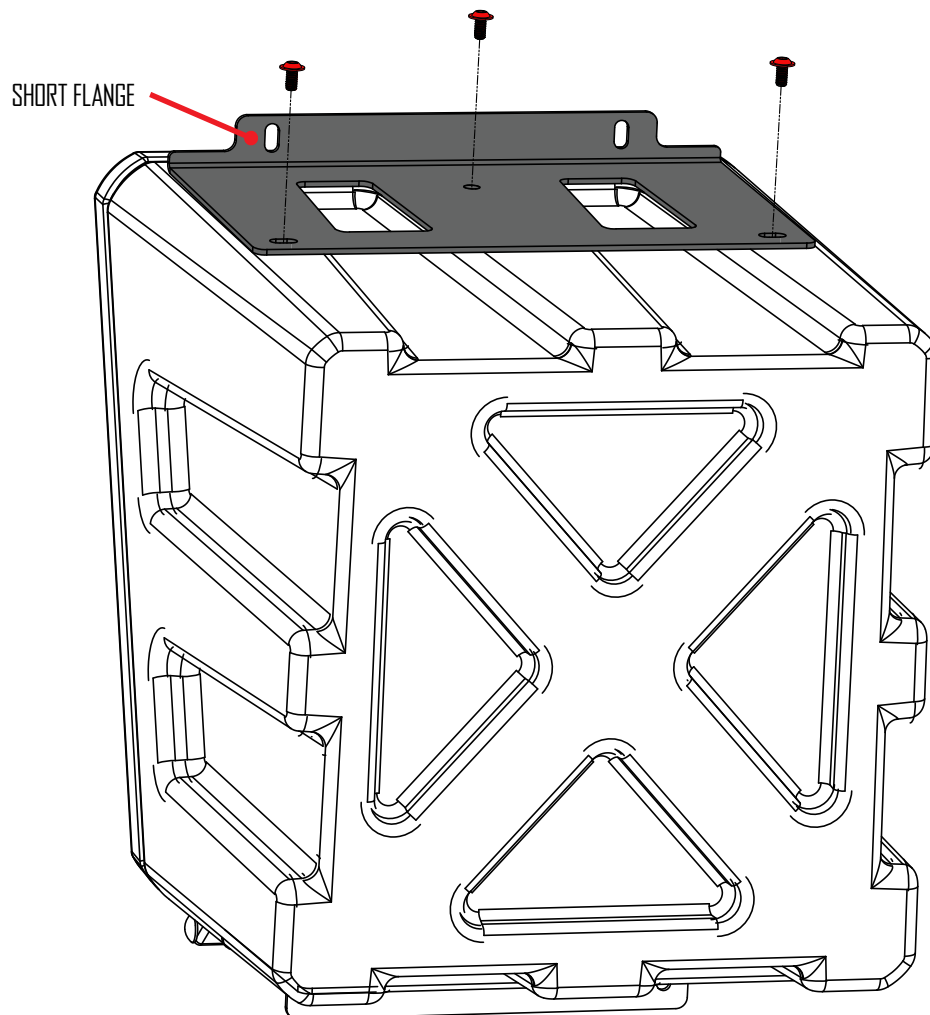

ASSEMBLE: FASTENERS TO GEAR POD MOUNTING PLATES

• INSTALL ONE M8 X 14 BOLT THROUGH EACH OVAL SLOT IN UPPER AND LOWER MOUNTING PLATE AND LOOSLY THREAD ON TRAKLOK NUT.

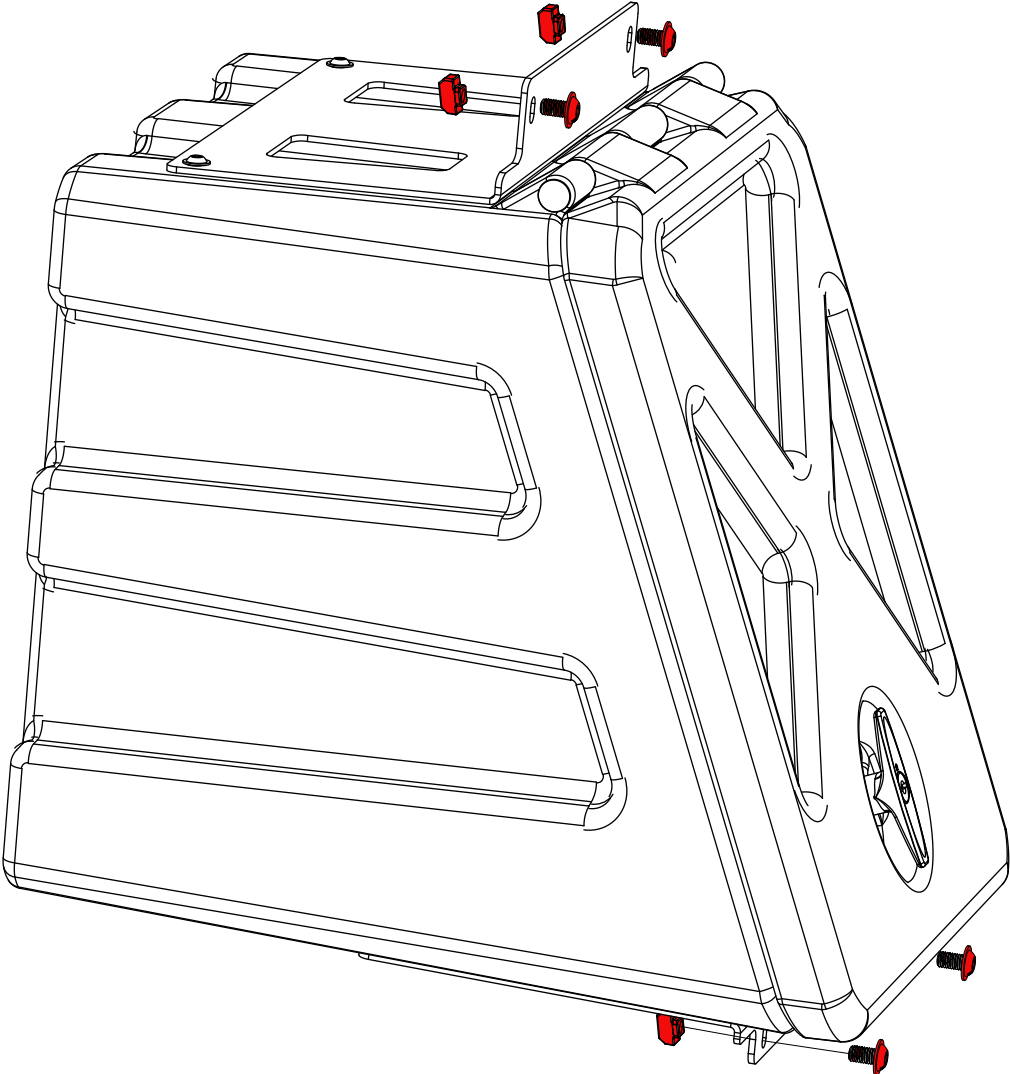

INSTALL: GEAR POD TO ACS

- ALIGN THE TRAKLOK NUTS WITH THE T-SLOTS IN THE ACS.
- USING A T40 TORX WRENCH TIGHTEN THE BOLTS TO 14 FT-LB.
- **NOTE: IT IS EXTREMELY IMPORTANT THAT THE TRAKLOK NUTS ROTATE FULLY INTO PLACE AS SHOWN IN DIAGRAM AND TIGHTEN DOWN UNDER THE LIP OF THE ALUMINUM EXTRUSSION.**

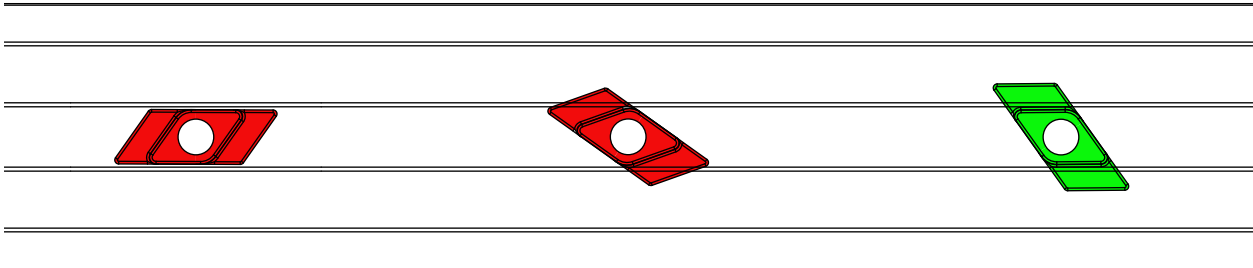
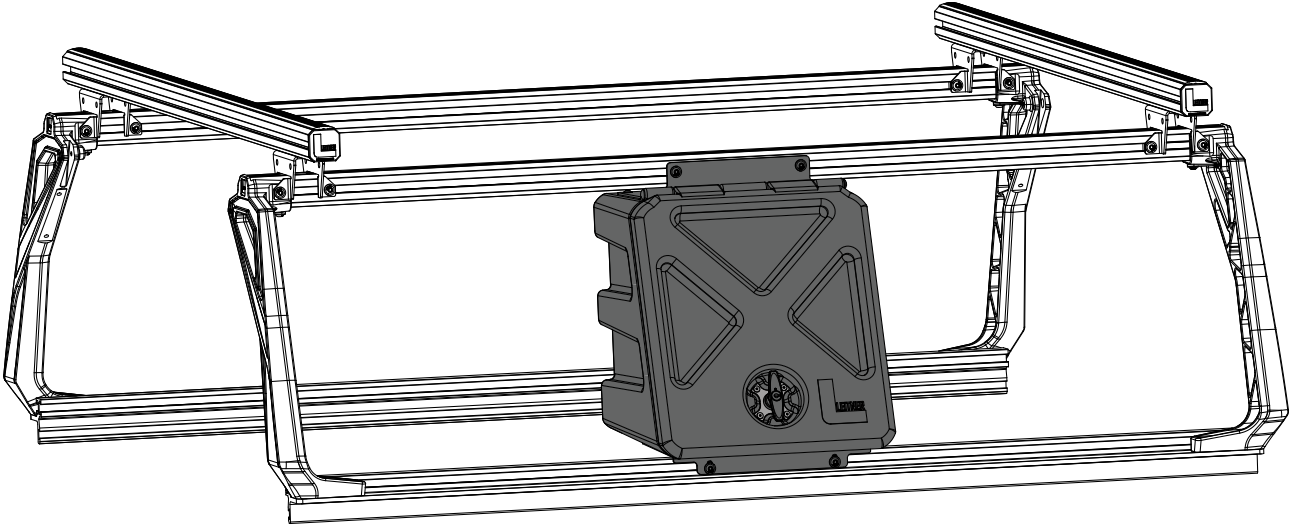

BAD

BAD

GOOD

EVERY EFFORT HAS BEEN MADE TO MAKE THE GEAR POD AS WATER TIGHT AS POSSIBLE. HOWEVER DUE TO MANUFACTURING TOLERANCE, DRIVING CONDITIONS AND WEATHER, WE DO NOT RECOMMEND STORING ITEMS THAT CAN BE DAMAGED BY WATER BEFORE PLACING THEM IN THERE OWN AIRTIGHT CONTAINER.

THE GEAR POD NOR ITS CONTENTS ARE WARRANTIED AGAINST WATER INTRUSION

USE GUIDELINES

WHEN USING LEITNER DESIGNS CARRIERS AND ACCESSORIES, THE USER MUST UNDERSTAND THE PRECAUTIONS. THE POINTS LISTED BELOW WILL ASSIST YOU IN USING THE RACK SYSTEM AND WILL ENCOURAGE SAFETY.

-FOR QUALITY FITS AND SAFETY, USE ONLY THE RECOMMENDED RACK OR ACCESSORIES. DO NOT ASSUME A RACK WILL FIT, ALWAYS CHECK THE CURRENT FIT GUIDE WHEN OBTAINING A NEW VEHICLE.

-THE MAXIMUM LOAD IS NOT TO BE EXCEEDED. (250# OFF ROAD – 500# ON ROAD). HOWEVER, THIS LIMIT IS ALWAYS SUBORDINATE TO THE MAXIMUM LOAD RECOMMENDED BY THE MANUFACTURER OF THE VEHICLE ITSELF. IT IS ALWAYS THE LOWER MAXIMUM RECOMMENDED LOAD THAT APPLIES. $\text{MAX TRUCK LOAD} = \text{LOAD CARRIER WEIGHT} + \text{ANY FITTED CARRIER ACCESSORIES} + \text{THE WEIGHT OF THE LOAD ITSELF}$.

-HIGH SPEED OFF ROAD DRIVING EVEN WITH A LIGHT LOAD CAN CAUSE DAMAGE TO THE RACK, ACCESSORIES AND VEHICLE BODY. DAMAGE CAUSED BY HIGH SPEED DRIVING AND ABUSE IS NOT COVERED UNDER WARRANTY.

-MAKE SURE ALL KNOBS, BOLTS, SCREWS, STRAPS, AND LOCKS ARE FIRMLY ATTACHED, TIGHTENED AND LOCKED BEFORE EVERY TRIP. KNOBS, BOLTS, SCREWS, STRAPS AND LOCKS MUST BE PERIODICALLY INSPECTED FOR SIGNS OF WEAR, CORROSION, AND FATIGUE. CHECK YOUR LOAD AT STOPS DURING THE TRIP TO ENSURE CONTINUED FASTENING SECURITY.

-CHECK LOCAL AND STATE LAWS GOVERNING PROJECTION OF OBJECTS BEYOND THE PERIMETER OF A VEHICLE. BE AWARE OF THE WIDTH AND HEIGHT OF YOUR CARGO SINCE LOW CLEARANCE BRANCHES, BRIDGES, AND PARKING GARAGES CAN AFFECT THE LOAD. ALL CARGO WILL AFFECT THE VEHICLE'S DRIVING BEHAVIOR. NEVER DRIVE WITH ANY LOCK, KNOB OR RACK IN AN OPEN OR UNLOCKED POSITION. ALL LONG LOADS SUCH AS, BUT NOT LIMITED TO, SAILBOARDS, SURFBOARDS, KAYAKS, CANOES, AND LUMBER MUST BE TIED DOWN FRONT AND REAR TO THE BUMPERS OR TOW HOOKS OF THE VEHICLE.

-ALL LOCKS MUST BE TURNED AND MOVED PERIODICALLY TO ENSURE SMOOTH OPERATION. USE GRAPHITE OR DRY LUBRICANT TO HELP THIS. LEITNER DESIGNS LOCKS ARE DESIGNED TO DETER VANDALISM AND THEFT BUT SHOULD NOT BE CONSIDERED THEFT PROOF. REMOVE VALUABLE GEAR IF YOUR VEHICLE IS UNATTENDED FOR AN EXTENDED PERIOD. PLACE AT LEAST ONE KEY IN THE GLOVE COMPARTMENT.

-FOR SAFETY TO YOUR VEHICLE AND RACK SYSTEM, OBEY ALL POSTED SPEED LIMITS AND TRAFFIC CAUTIONS. ADAPT YOUR SPEED TO THE CONDITIONS OF THE ROAD AND THE LOAD BEING CARRIED.

-DO NOT USE LEITNER DESIGNS LOAD CARRIERS AND ACCESSORIES FOR PURPOSES OTHER THAN THOSE FOR WHICH THEY WERE DESIGNED. DO NOT EXCEED THEIR CARRYING CAPACITY. FAILURE TO FOLLOW THESE GUIDELINES OR THE PRODUCT'S INSTRUCTIONS WILL VOID THE WARRANTY.

WARRANTY

LEITNER DESIGNS WARRANTS PRODUCT TO BE FREE FROM DEFECTS IN MATERIAL AND WORKMANSHIP, FOR TERMS SPECIFIED BELOW, PROVIDED THERE HAS BEEN NORMAL USE AND PROPER MAINTENANCE. ALL REMEDIES UNDER THIS WARRANTY ARE LIMITED TO THE REPAIR OR REPLACEMENT OF ANY ITEM FOUND BY THE FACTORY TO BE DEFECTIVE WITHIN THE TIME PERIOD SPECIFIED. IF YOU HAVE A WARRANTY CLAIM, FIRST YOU MUST CALL OUR FACTORY AT THE NUMBER BELOW FOR INSTRUCTIONS. YOU MUST RETAIN PROOF OF PURCHASE AND SUBMIT A COPY WITH ANY ITEMS RETURNED FOR WARRANTY WORK. UPON COMPLETION OF WARRANTY WORK, IF ANY, WE WILL RETURN THE REPAIRED OR REPLACED ITEM OR ITEMS TO YOU FREIGHT PREPAID. DAMAGE TO OUR PRODUCTS CAUSED BY ACCIDENTS, FIRE, VANDALISM, NEGLIGENCE, MIS-INSTALLATION, MISUSE, ACTS OF GOD, OR BY DEFECTIVE PARTS NOT MANUFACTURED BY US, IS NOT COVERED UNDER THIS WARRANTY.

THE WARRANTY TIME PERIOD IS AS FOLLOWS: (2) TWO YEARS FROM DATE OF PURCHASE.

HIGH SPEED OFF ROAD DRIVING EVEN WITH A LIGHT LOAD CAN CAUSE DAMAGE TO THE RACK, ACCESSORIES AND VEHICLE BODY. DAMAGE CAUSED BY HIGH SPEED OFF ROAD DRIVING AND ABUSE IS NOT COVERED UNDER WARRANTY.

GEAR PODS ARE WATER RESISTANT AND NOT WATERPROOF. ITEMS THAT CAN BE DAMAGED BY WATER SHOULD BE STORED INSIDE THERE OWN AIR TIGHT CONTAINER BEFORE BEING PLACED IN THE GEAR POD.

THE GEAR POD NOR ITS CONTENTS ARE WARRANTIED AGAINST WATER INTRUSION.

ANY IMPLIED WARRANTIES OF MERCHANTABILITY AND/OR FITNESS FOR A PARTICULAR PURPOSE CREATED HEREBY ARE LIMITED IN DURATION TO THE SAME DURATION AND SCOPE AS THE EXPRESS WRITTEN WARRANTY. OUR COMPANY SHALL NOT BE LIABLE FOR ANY INCIDENTAL OR CONSEQUENTIAL DAMAGE.

SOME STATES DO NOT ALLOW LIMITATIONS ON HOW LONG AN IMPLIED WARRANTY LASTS, OR THE EXCLUSION OR LIMITATION OF INCIDENTAL OR CONSEQUENTIAL DAMAGES, SO THE ABOVE LIMITATIONS OR EXCLUSIONS MAY NOT APPLY TO YOU. THIS WARRANTY GIVES YOU SPECIFIC LEGAL RIGHTS, AND YOU MAY ALSO HAVE OTHER RIGHTS THAT VARY FROM STATE TO STATE.

FOR WARRANTY ISSUES WITH THIS PRODUCT PLEASE CALL LEITNER DESIGNS CUSTOMER SERVICE **949-395-3049** OR EMAIL US AT **SUPPORT@LEITNERDESIGNS.COM**