

# LEITNER

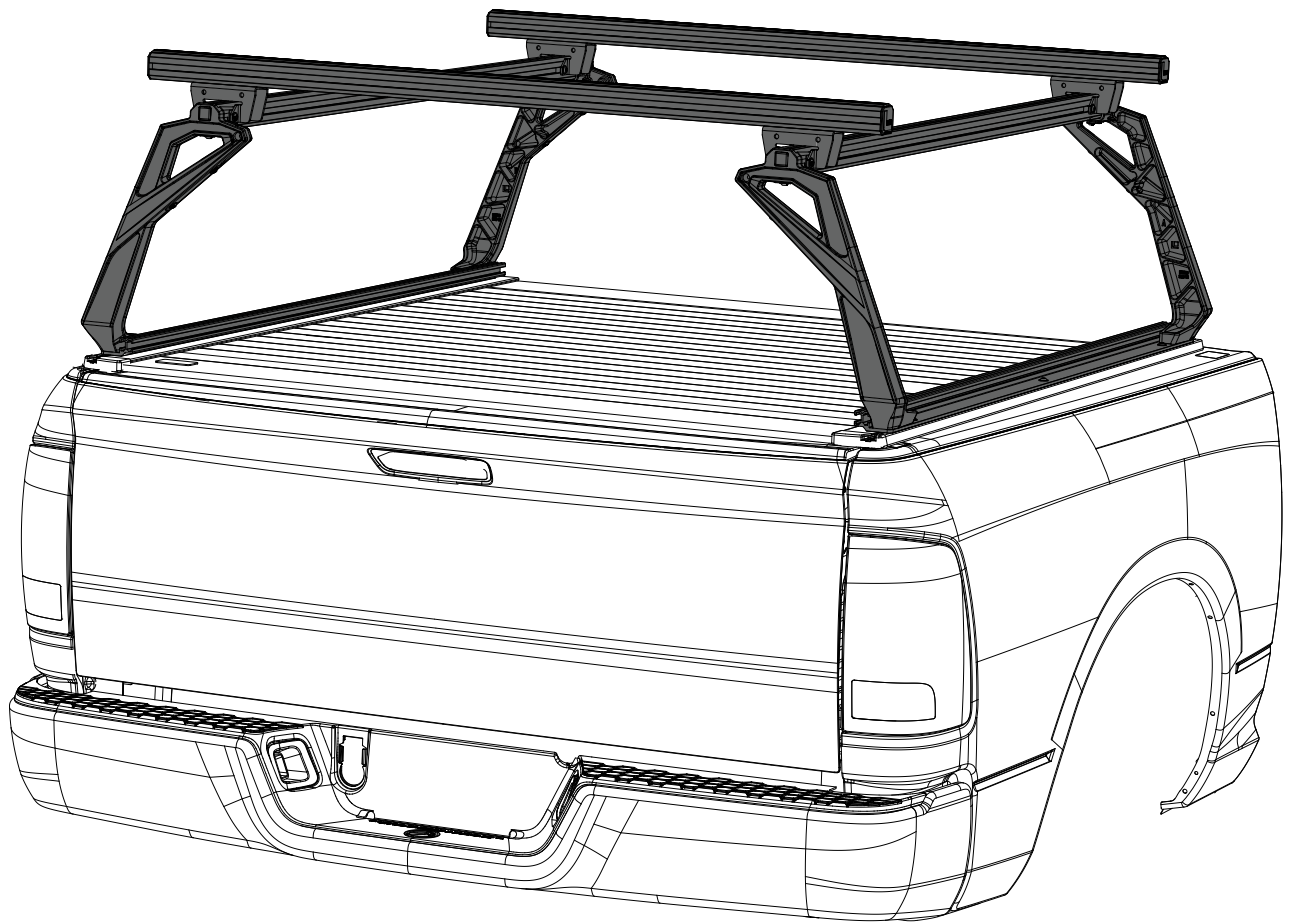

**TONNEAU**

LEITNERDESIGNS.COM | SUPPORT@LEITNERDESIGNS.COM | 949-395-3049

# ASSEMBLY / INSTALLATION INSTRUCTIONS:

## ACTIVE CARGO SYSTEM PART NUMBERS:

- 00-50-FTA-1375 (5-0' BED LENGTH)
- 00-56-FTA-1376 (5-1/2' BED LENGTH)
- 00-60-FTA-1377 (6-0' BED LENGTH)
- 00-64-FTA-1378 (6'-4" BED LENGTH)
- 00-66-FTA-1379 (6-1/2' BED LENGTH)

---

## TOOLS REQUIRED

- TORQUE WRENCH
- T40 TORX
- 5MM HEX BIT SOCKET
- TAPE MEASURE

## INSTALLATION TIME

**2-3 HOURS**

BASIC KNOWLEDGE OF HAND TOOLS REQUIRED

## SKILL LEVEL



3= INTERMEDIATE

## TOOLS INCLUDED

- T30 TORX WRENCH
- T40 TORX WRENCH

# ▼ READ BEFORE INSTALLING ACTIVE CARGO SYSTEM ▼

## 1. TONNEAU COVER MUST BE INSTALLED ON TRUCK BEFORE BEGINNING ASSEMBLY.

2. DON'T OVER-TIGHTEN BOLTS. ALL 10MM BOLTS = (40LB-FT) ALL 8MM BOLTS = (18FT-LB)

3. LAY DOWN A LARGE AREA OF CARPET OR BLANKETS AS A WORK AREA TO AVOID SCRATCHING PARTS DURING ASSEMBLY.

4. ALTHOUGH THE ACTIVE CARGO SYSTEM IS LIGHT HAVING A FRIEND TO HELP IS RECOMMENDED.

## ▼ ASSEMBLY OVERVIEW ▼

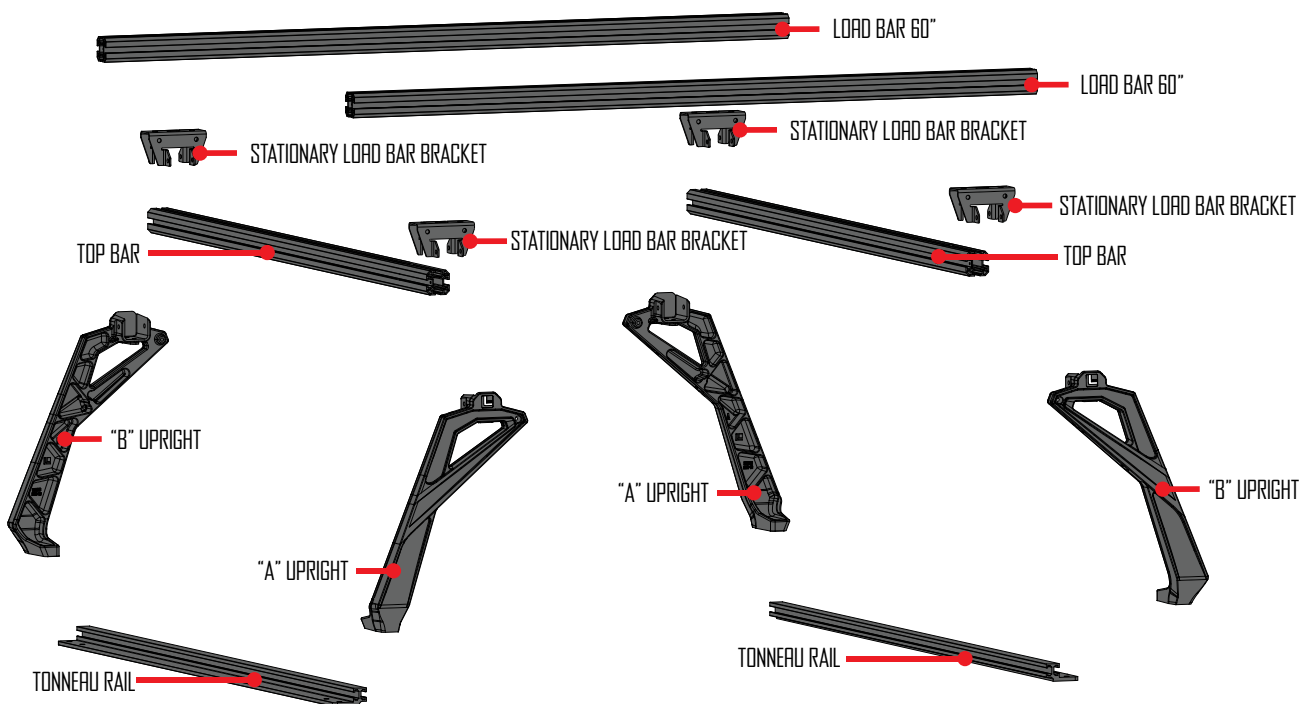

# ▼ ACTIVE CARGO SYSTEM HARDWARE ▼

LONG T-NUT  
(X12)



SHORT T-NUT  
(X4)

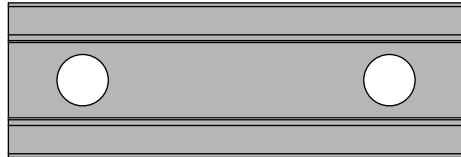

SINGLE T-NUT  
(X4)

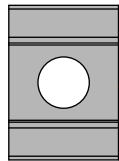

**NOT USED WITH TONNEAU  
COMPATIBLE RACK**

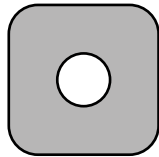

RETRAX TONNEAU NUT  
(X6)

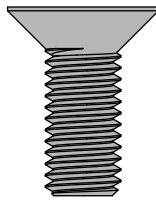

M10 X 22  
(X8)

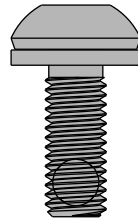

M8 X 20  
(X16)

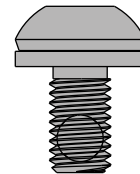

M8 X 14  
(X22)

FOR USE WITH PACE EDWARDS TONNEAU COVER

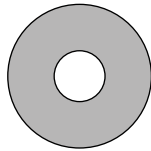

5/16 WASHER  
(X6)

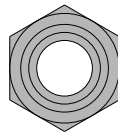

5/16 LOCKNUT  
(X6)

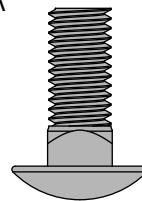

5/16 CARRIAGE BOLT  
(X6)

# PREP: LOAD BAR BRACKETS

- INSTALL 2 M8 X 14 BOLTS THROUGH BRACKET AND THREAD INTO LONG T-NUT. ONLY START A FEW THREADS AND DO NOT TIGHTEN.
- REPEAT STEPS BELOW FOR ALL FOUR BRACKET.
- SET ASIDE FOR USE IN A LATER STEP.

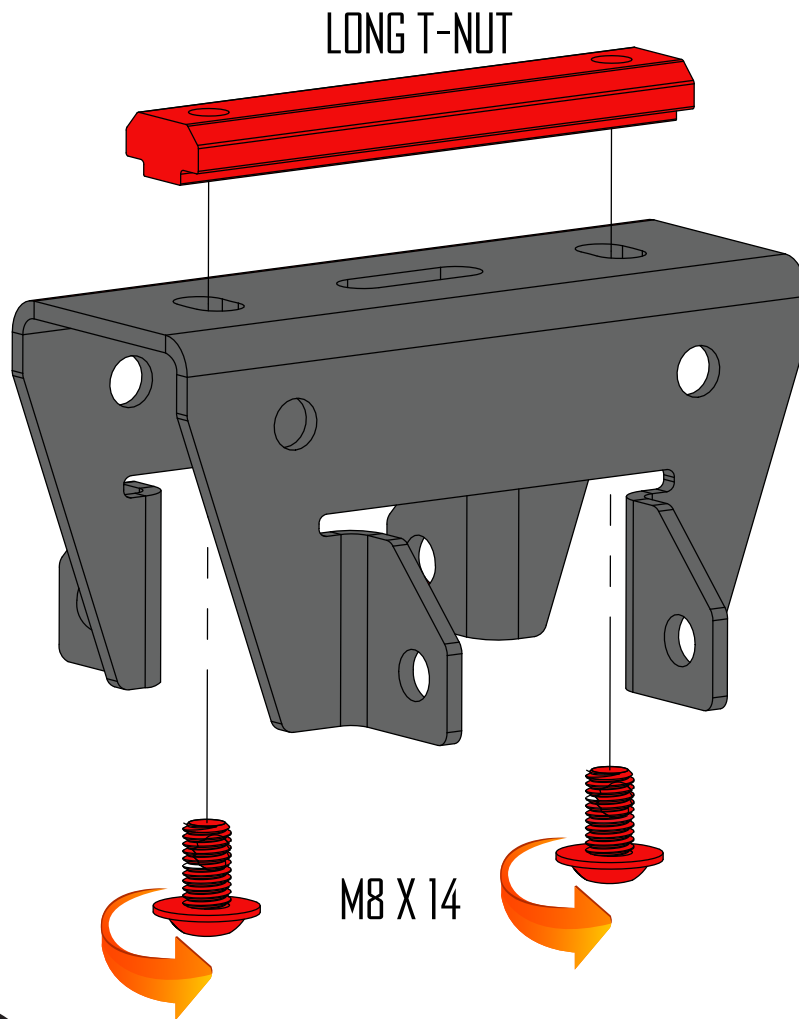

4X

# ASSEMBLE ACS SIDE: OVERVIEW

- IN THE NEXT FEW STEPS YOU WILL ASSEMBLE THE DRIVERS AND PASSENGER SIDE PORTION OF THE ACTIVE CARGO SYSTEM.
- THE ILLUSTRATION BELLOW SHOWS WHAT THE PART WILL LOOK LIKE WHEN FULLY ASSEMBLED. YOU CAN REFER BACK TO THIS ILLUSTRATION AT ANY TIME TO CLARIFY PART LOCATION.

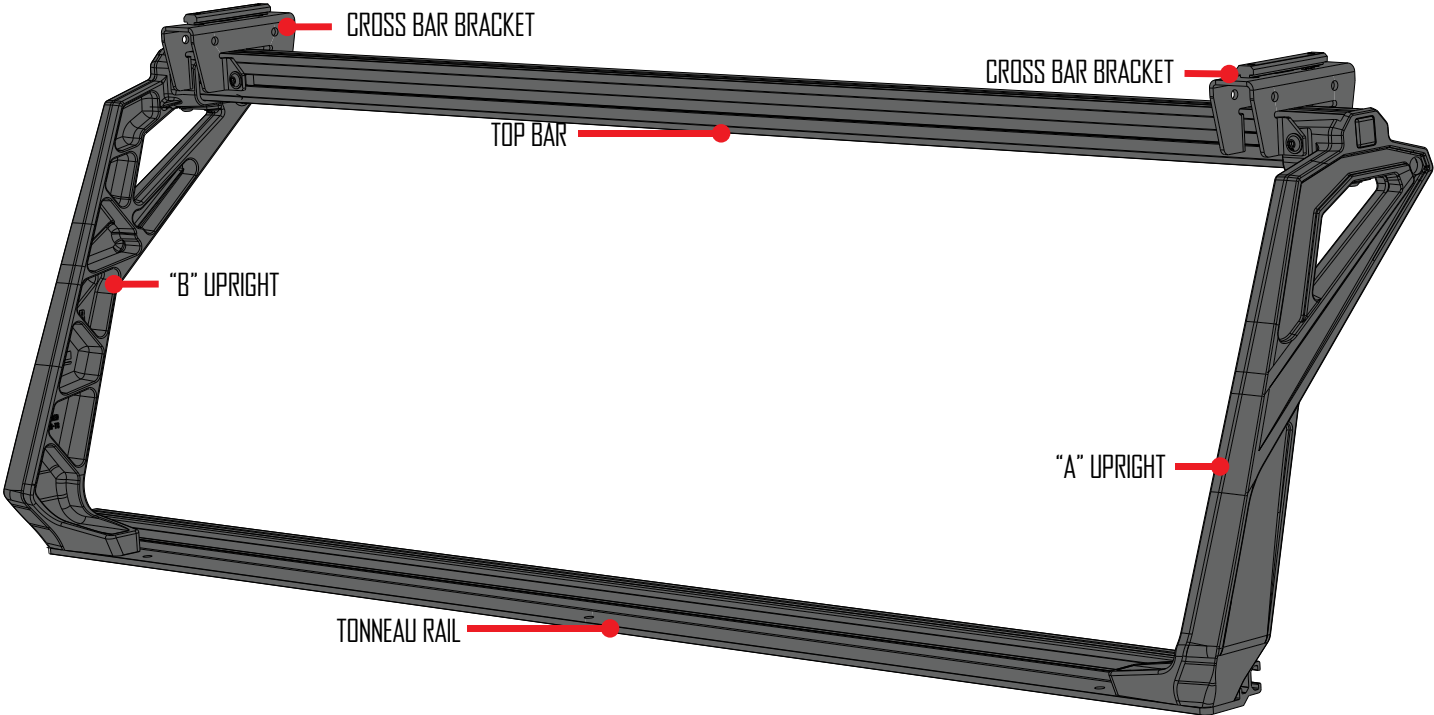

**2X**

# ASSEMBLE: UPRIGHT "A"

- ASSEMBLE UPRIGHTS MARKED "A" AS SHOWN IN THE FOLLOWING DIAGRAM.
- THREAD TWO M8 X 20 BOLTS INTO THE SHORT T-NUT. (FIG-A) **START A FEW THREADS AND DO NOT TIGHTEN..**
- THREAD TWO M8X 20 BOLTS THROUGH CROSS BAR BRACKET AND UPRIGHT INTO LONG T-NUT (FIG-B) **START A FEW THREADS AND DO NOT TIGHTEN..**
- THREAD TWO M8X 14 BOLTS THROUGH CROSS BAR BRACKET INTO LONG T-NUT (FIG-B) **START A FEW THREADS AND DO NOT TIGHTEN..**

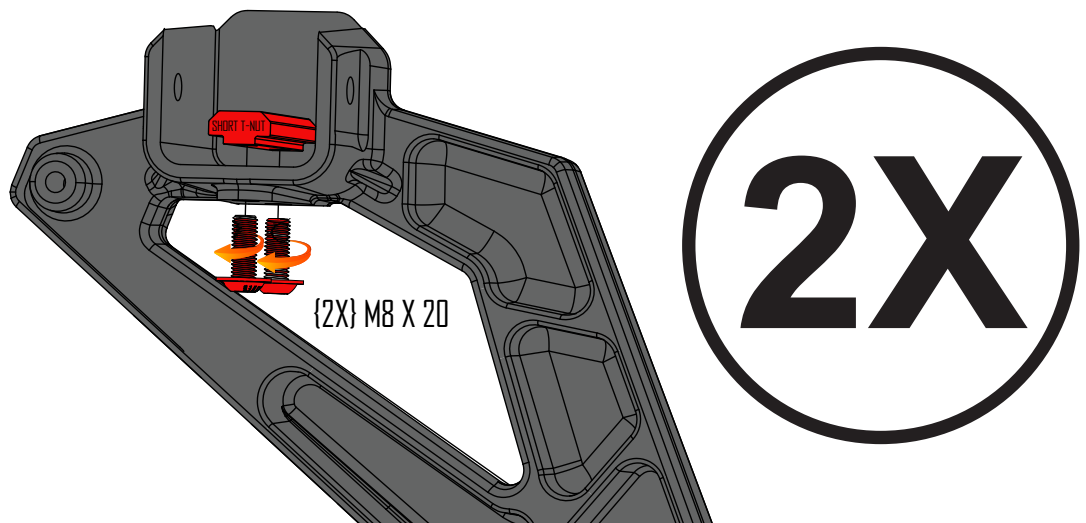

FIG-A

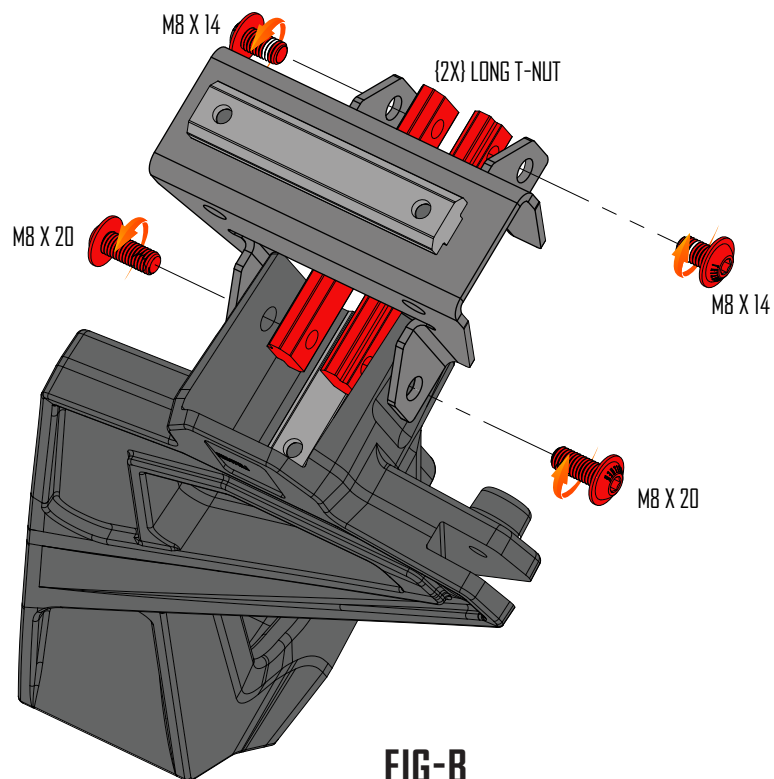

FIG-B

# ASSEMBLE: UPRIGHT "B"

- ASSEMBLE UPRIGHTS AS SHOWN IN THE FOLLOWING DIAGRAM.
- THREAD TWO M8 X 20 BOLTS INTO THE SHORT T-NUT. (FIG-A) **START A FEW THREADS AND DO NOT TIGHTEN.**
- THREAD TWO M8X 20 BOLTS THROUGH CROSS BAR BRACKET AND UPRIGHT INTO LONG T-NUT (FIG-B) **START A FEW THREADS AND DO NOT TIGHTEN.**
- THREAD TWO M8X 14 BOLTS THROUGH CROSS BAR BRACKET INTO LONG T-NUT (FIG-B) **START A FEW THREADS AND DO NOT TIGHTEN.**

2X

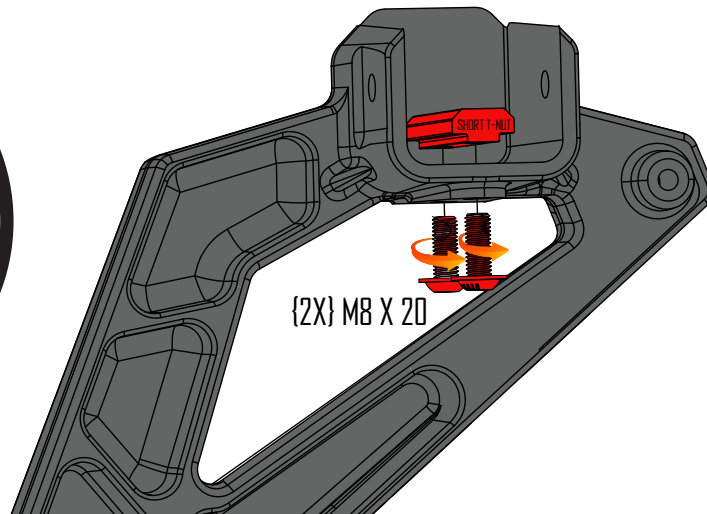

FIG-A

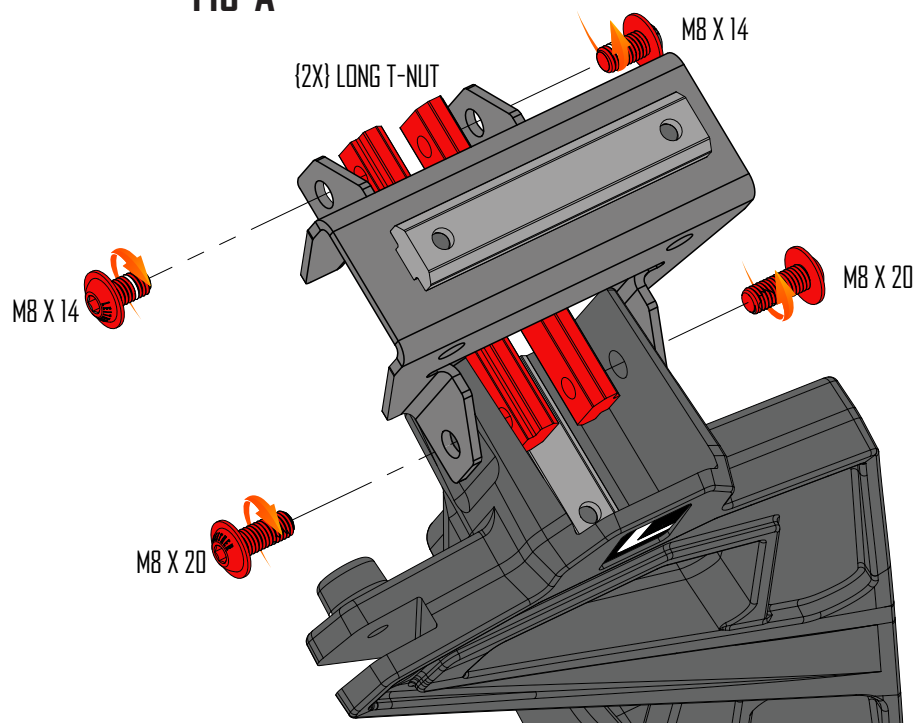
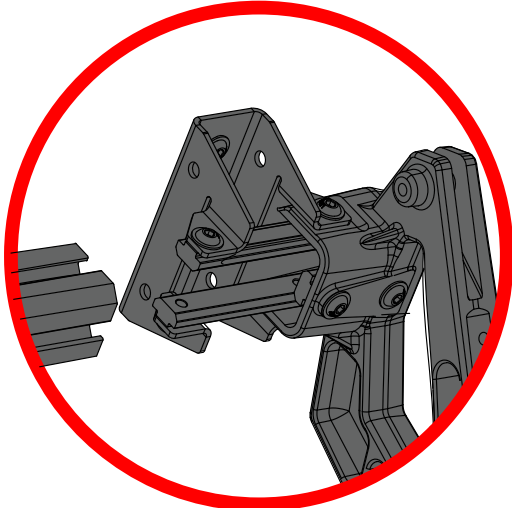
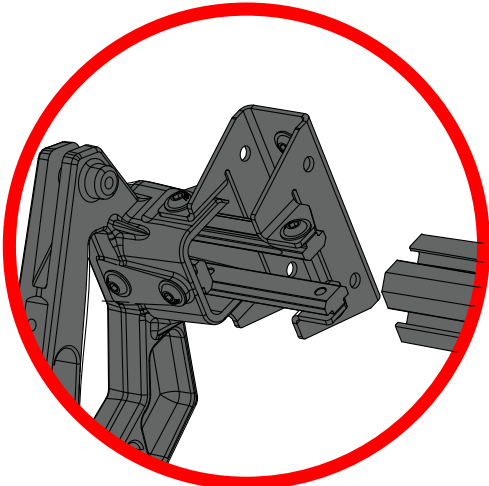

FIG-B



# ASSEMBLE: TOP BAR

· ATTACH A & B UPRIGHT ASSEMBLY'S TO TOP BAR AS SHOWN IN ILLUSTRATION BELOW. **DO NOT TIGHTEN BOLTS AT THIS TIME.**



2X

# ASSEMBLE: RAIL

- ATTACH RAIL TO UPRIGHTS USING FOUR M10 X 25 SCREWS. TORQUE TO 40 FT-LB USING A T40 TORX WRENCH.
- TORQUE ALL M8 BOLTS INSTALLED IN PREVIOUS STEP TO 18 FT-LB USING AT40 TORX WRENCH.
- **IMPORTANT: TIGHTEN M10X25 RAIL BOLTS FIRST THEN TORQUE THE M8 BOLTS.**



2X

# ASSEMBLE: INSTALL NUTS INTO RETRAX RAILS

- INSTALL 3 TONNEAU NUTS INTO EACH RETRAX BED RAIL T-SLOT.
- SPACE THEM APART THE SAME DISTANCE AS THE MOUNTING HOLES IN THE ACS TONNEAU RAILS.

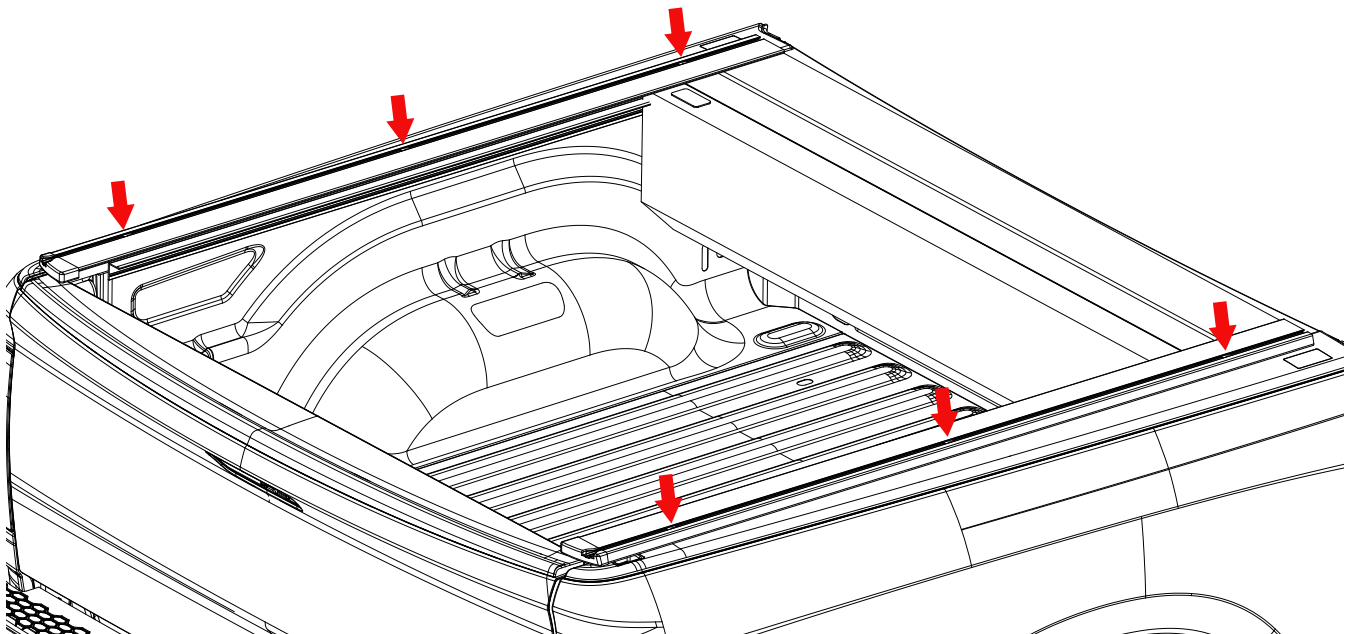
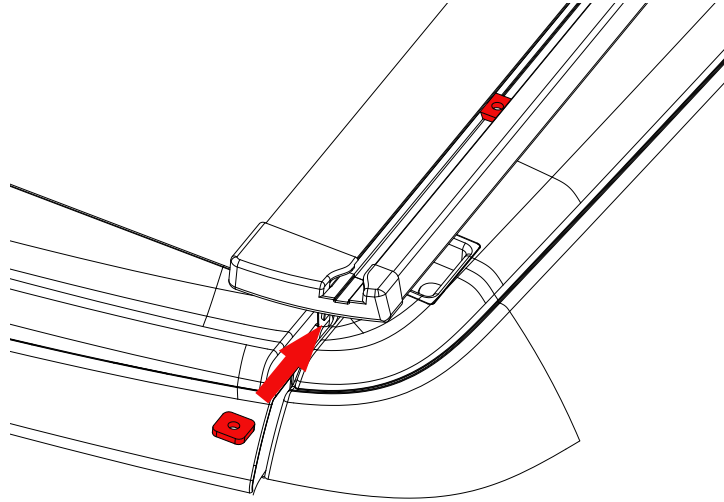

# INSTALL: UPRIGHT ASSEMBLIES TO TRUCK

- **THIS NEXT STEP IS BEST DONE USING TWO PEOPLE TO HELP STABILIZE THE RACK ASSEMBLY!!**
- USING A M8 X 14 BOLT ATTACH THE RIGHT AND LEFT ASSEMBLIES TO THE TRUCK.
- MAKE SURE BOTH PASSENGER AND DRIVERS SIDE ARE IN THE SAME LOCATION AS MEASURED FRONT TO BACK ON THE TRUCK BED.

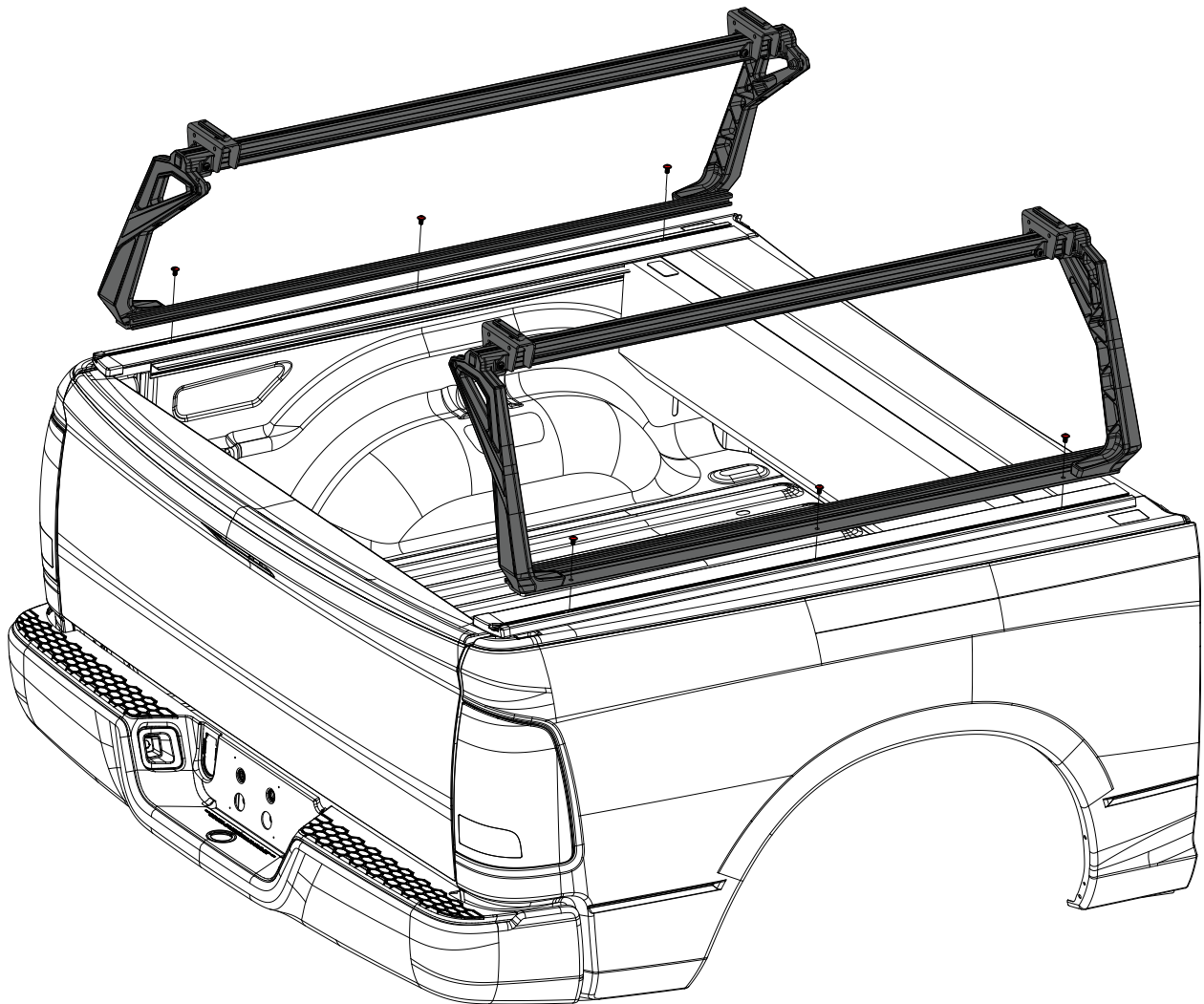

# INSTALL: LOAD BARS

- SLIDE THE 60" LONG LOAD BARS ONTO THE T-NUTS INTO THE LOAD BAR BRACKETS AND CENTER THEM ON THE RACK.
- TIGHTEN THE M8 X 14 BOLTS ON THE UNDERSIDE OF THE BRACKETS MAKING SURE THE LOAD BARS STAY CENTERED

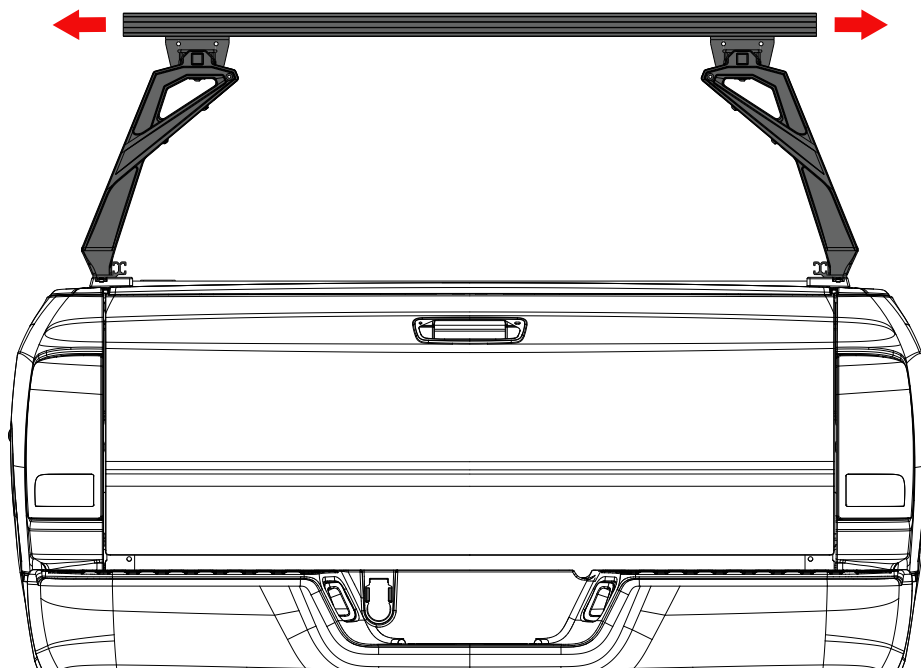
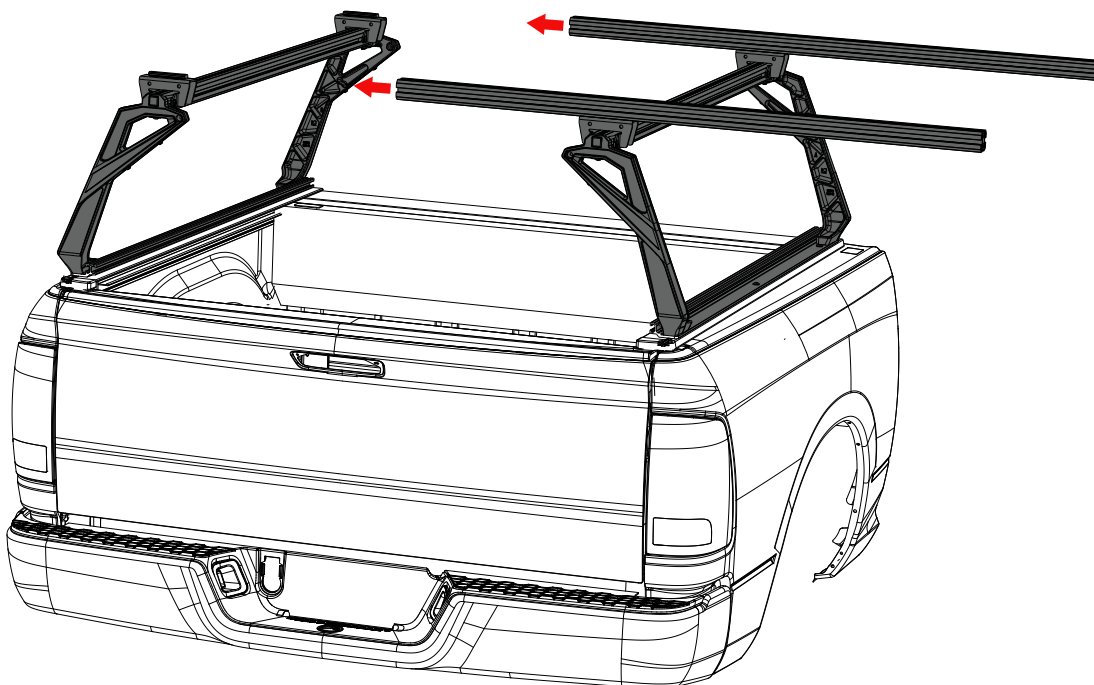

# FINISH: INSTALL END CAPS AND RUBBER TREAD STRIP

• INSTALL THE RUBBER TREAD STRIP INTO THE UPPER CROSS BAR CHANNEL BY PUSHING IT INTO THE T-SLOT WITH THE PALM OF YOUR HAND. NOTE: SOME TRIMMING OF THE RUBBER TREAD STRIP MIGHT BE NECESSARY.

• INSTALL THE FOUR END CAPS INTO THE ENDS OF THE CROSS BARS.

**CHECK ALL FASTENERS INSTALLED IN PREVIOUS STEPS TO ENSURE THEY ARE PROPERLY TIGHTENED**

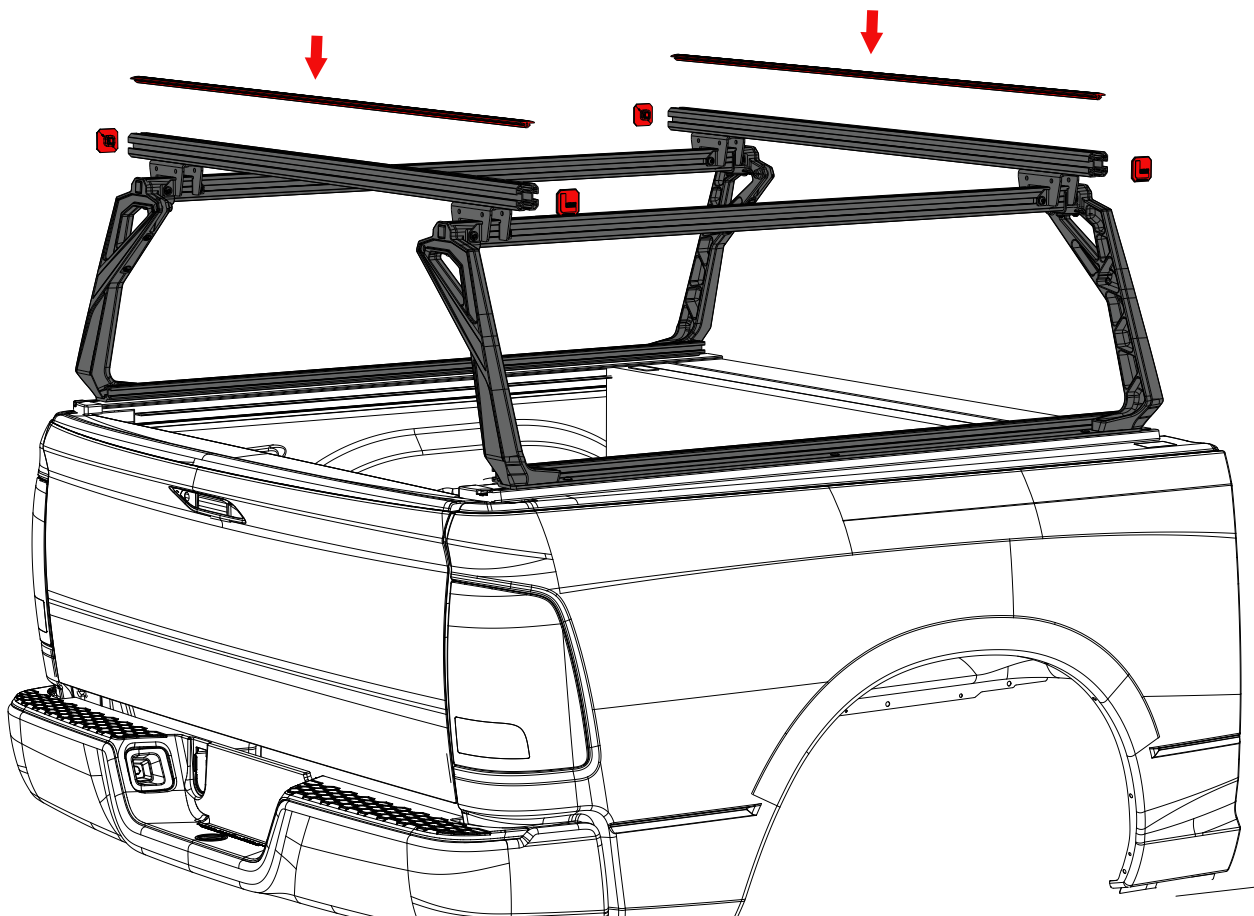

# USE GUIDELINES

WHEN USING LEITNER DESIGNS CARRIERS AND ACCESSORIES, THE USER MUST UNDERSTAND THE PRECAUTIONS. THE POINTS LISTED BELOW WILL ASSIST YOU IN USING THE RACK SYSTEM AND WILL ENCOURAGE SAFETY.

-FOR QUALITY FITS AND SAFETY, USE ONLY THE RECOMMENDED RACK OR ACCESSORIES. DO NOT ASSUME A RACK WILL FIT, ALWAYS CHECK THE CURRENT FIT GUIDE WHEN OBTAINING A NEW VEHICLE.

-THE MAXIMUM LOAD IS NOT TO BE EXCEEDED. ( 400# ON ROAD - 800# STATIC). HOWEVER, THIS LIMIT IS ALWAYS SUBORDINATE TO THE MAXIMUM LOAD RECOMMENDED BY THE MANUFACTURER OF THE VEHICLE ITSELF. IT IS ALWAYS THE LOWER MAXIMUM RECOMMENDED LOAD THAT APPLIES. MAX TRUCK LOAD = LOAD CARRIER WEIGHT + ANY FITTED CARRIER ACCESSORIES + THE WEIGHT OF THE LOAD ITSELF.

**- THE ACS TONNEAU IS NOT RECOMMENDED FOR OFF ROAD USE. OFF ROAD DRIVING EVEN WITH A LIGHT LOAD CAN CAUSE DAMAGE TO THE TONNEAU, RACK, ACCESSORIES AND VEHICLE BODY. DAMAGE CAUSED BY OFF ROAD DRIVING AND ABUSE IS NOT COVERED UNDER WARRANTY.**

-MAKE SURE ALL KNOBS, BOLTS, SCREWS, STRAPS, AND LOCKS ARE FIRMLY ATTACHED, TIGHTENED AND LOCKED BEFORE EVERY TRIP. KNOBS, BOLTS, SCREWS, STRAPS AND LOCKS MUST BE PERIODICALLY INSPECTED FOR SIGNS OF WEAR, CORROSION, AND FATIGUE. CHECK YOUR LOAD AT STOPS DURING THE TRIP TO ENSURE CONTINUED FASTENING SECURITY.

-CHECK LOCAL AND STATE LAWS GOVERNING PROJECTION OF OBJECTS BEYOND THE PERIMETER OF A VEHICLE. BE AWARE OF THE WIDTH AND HEIGHT OF YOUR CARGO SINCE LOW CLEARANCE BRANCHES, BRIDGES, AND PARKING GARAGES CAN AFFECT THE LOAD. ALL CARGO WILL AFFECT THE VEHICLE'S DRIVING BEHAVIOR. NEVER DRIVE WITH ANY LOCK, KNOB OR RACK IN AN OPEN OR UNLOCKED POSITION. ALL LONG LOADS SUCH AS, BUT NOT LIMITED TO, SAILBOARDS, SURFBOARDS, KAYAKS, CANOES, AND LUMBER MUST BE TIED DOWN FRONT AND REAR TO THE BUMPERS OR TOW HOOKS OF THE VEHICLE.

-ALL LOCKS MUST BE TURNED AND MOVED PERIODICALLY TO ENSURE SMOOTH OPERATION. USE GRAPHITE OR DRY LUBRICANT TO HELP THIS. LEITNER DESIGNS LOCKS ARE DESIGNED TO DETER VANDALISM AND THEFT BUT SHOULD NOT BE CONSIDERED THEFT PROOF. REMOVE VALUABLE GEAR IF YOUR VEHICLE IS UNATTENDED FOR AN EXTENDED PERIOD. PLACE AT LEAST ONE KEY IN THE GLOVE COMPARTMENT.

-FOR SAFETY TO YOUR VEHICLE AND RACK SYSTEM, OBEY ALL POSTED SPEED LIMITS AND TRAFFIC CAUTIONS. ADAPT YOUR SPEED TO THE CONDITIONS OF THE ROAD AND THE LOAD BEING CARRIED.

-DO NOT USE LEITNER DESIGNS LOAD CARRIERS AND ACCESSORIES FOR PURPOSES OTHER THAN THOSE FOR WHICH THEY WERE DESIGNED. DO NOT EXCEED THEIR CARRYING CAPACITY. FAILURE TO FOLLOW THESE GUIDELINES OR THE PRODUCT'S INSTRUCTIONS WILL VOID THE WARRANTY.

# WARRANTY

LEITNER DESIGNS WARRANTS PRODUCT TO BE FREE FROM DEFECTS IN MATERIAL AND WORKMANSHIP, FOR TERMS SPECIFIED BELOW, PROVIDED THERE HAS BEEN NORMAL USE AND PROPER MAINTENANCE. ALL REMEDIES UNDER THIS WARRANTY ARE LIMITED TO THE REPAIR OR REPLACEMENT OF ANY ITEM FOUND BY THE FACTORY TO BE DEFECTIVE WITHIN THE TIME PERIOD SPECIFIED. IF YOU HAVE A WARRANTY CLAIM, FIRST YOU MUST CALL OUR FACTORY AT THE NUMBER BELOW FOR INSTRUCTIONS. YOU MUST RETAIN PROOF OF PURCHASE AND SUBMIT A COPY WITH ANY ITEMS RETURNED FOR WARRANTY WORK. UPON COMPLETION OF WARRANTY WORK, IF ANY, WE WILL RETURN THE REPAIRED OR REPLACED ITEM OR ITEMS TO YOU FREIGHT PREPAID. DAMAGE TO OUR PRODUCTS CAUSED BY ACCIDENTS, FIRE, VANDALISM, NEGLIGENCE, MIS-INSTALLATION, MISUSE, ACTS OF GOD, OR BY DEFECTIVE PARTS NOT MANUFACTURED BY US, IS NOT COVERED UNDER THIS WARRANTY.

THE WARRANTY TIME PERIOD IS AS FOLLOWS: (S) TWO YEARS FROM DATE OF PURCHASE.

**OFF ROAD DRIVING EVEN WITH A LIGHT LOAD CAN CAUSE DAMAGE TO THE TONNEAU, RACK, ACCESSORIES AND VEHICLE BODY. DAMAGE CAUSED BY OFF ROAD DRIVING AND ABUSE IS NOT COVERED UNDER WARRANTY.**

ANY IMPLIED WARRANTIES OF MERCHANTABILITY AND/OR FITNESS FOR A PARTICULAR PURPOSE CREATED HEREBY ARE LIMITED IN DURATION TO THE SAME DURATION AND SCOPE AS THE EXPRESS WRITTEN WARRANTY. OUR COMPANY SHALL NOT BE LIABLE FOR ANY INCIDENTAL OR CONSEQUENTIAL DAMAGE.

SOME STATES DO NOT ALLOW LIMITATIONS ON HOW LONG AN IMPLIED WARRANTY LASTS, OR THE EXCLUSION OR LIMITATION OF INCIDENTAL OR CONSEQUENTIAL DAMAGES, SO THE ABOVE LIMITATIONS OR EXCLUSIONS MAY NOT APPLY TO YOU. THIS WARRANTY GIVES YOU SPECIFIC LEGAL RIGHTS, AND YOU MAY ALSO HAVE OTHER RIGHTS THAT VARY FROM STATE TO STATE.

FOR WARRANTY ISSUES WITH THIS PRODUCT PLEASE CALL LEITNER DESIGNS CUSTOMER SERVICE **949-395-3049** OR EMAIL US AT **SUPPORT@LEITNERDESIGNS.COM**