

LEITNER DESIGNS

ACTIVE CARGO SYSTEM

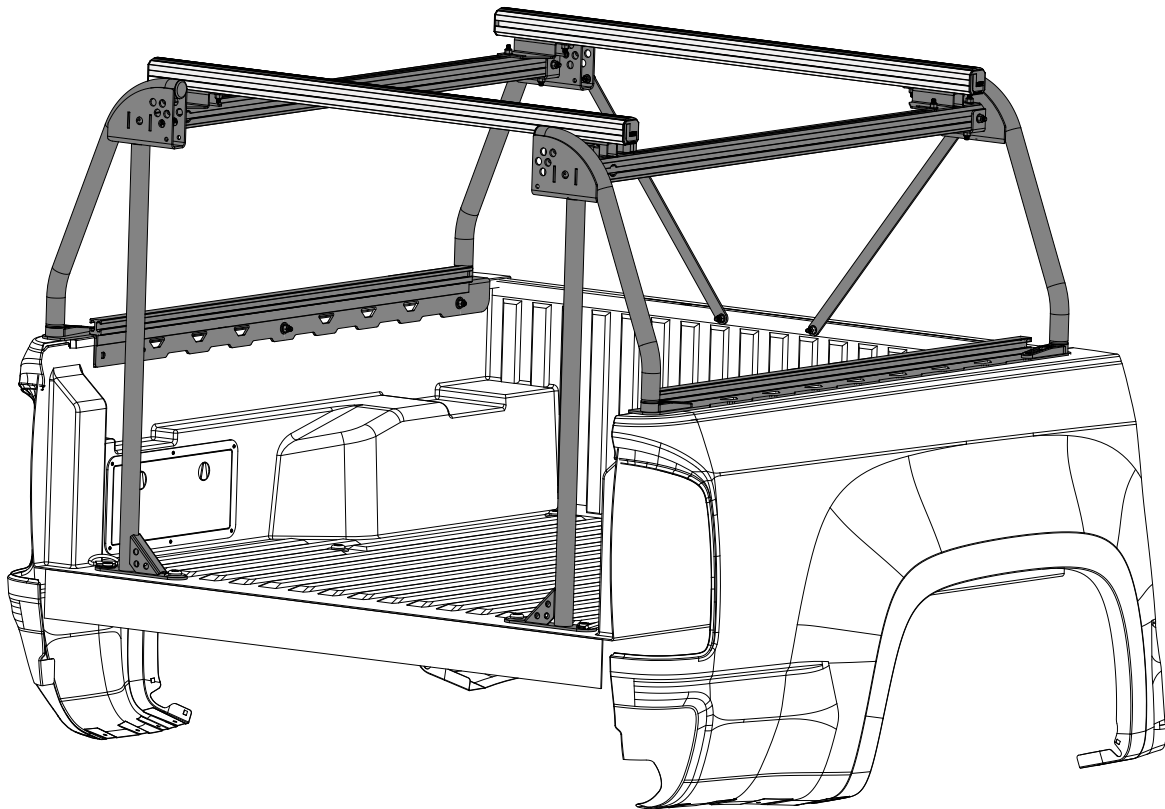

2016-CURRENT TOYOTA TACOMA

LEITNERDESIGNS.COM | SALES@LEITNERDESIGNS.COM | 949-395-3049

ASSEMBLY / INSTALLATION INSTRUCTIONS:

ACTIVE CARGO SYSTEM PART NUMBERS:

04-0060-M-01-1181 (2016-2018 TOYOTA TACOMA 5-0' BED LENGTH)

04-0073-M-01-1185 (2016-2018 TOYOTA TACOMA 6-0' BED LENGTH)

TOOLS REQUIRED

- TORQUE WRENCH
- 10MM SOCKET
- 13MM DEEP SOCKET
- 19MM SOCKET
- 12MM COMBINATION WRENCH
- 13MM COMBINATION WRENCH
- TAPE MEASURE

INSTALLATION TIME

2-3 HOURS

BASIC KNOWLEDGE OF HAND TOOLS REQUIRED

SKILL LEVEL



2= NOVICE

TOOLS INCLUDED

- T40 TORX DRIVER
- T55 TORX DRIVER

LEITNERDESIGNS.COM | SALES@LEITNERDESIGNS.COM | 949-395-3049

▼ READ BEFORE INSTALLING ACTIVE CARGO SYSTEM ▼

1. DON'T OVER-TIGHTEN BOLTS. ALL 12MM BOLTS = (55LB-FT) ALL 8MM BOLTS = (18FT-LB)
2. LAY DOWN A LARGE AREA OF CARPET OR BLANKETS AS A WORK AREA TO AVOID SCRATCHING PARTS DURING ASSEMBLY.
3. ALTHOUGH THE ACTIVE CARGO SYSTEM IS LIGHT HAVING A FRIEND TO HELP IS RECOMMENDED.

▼ ASSEMBLY OVERVIEW ▼

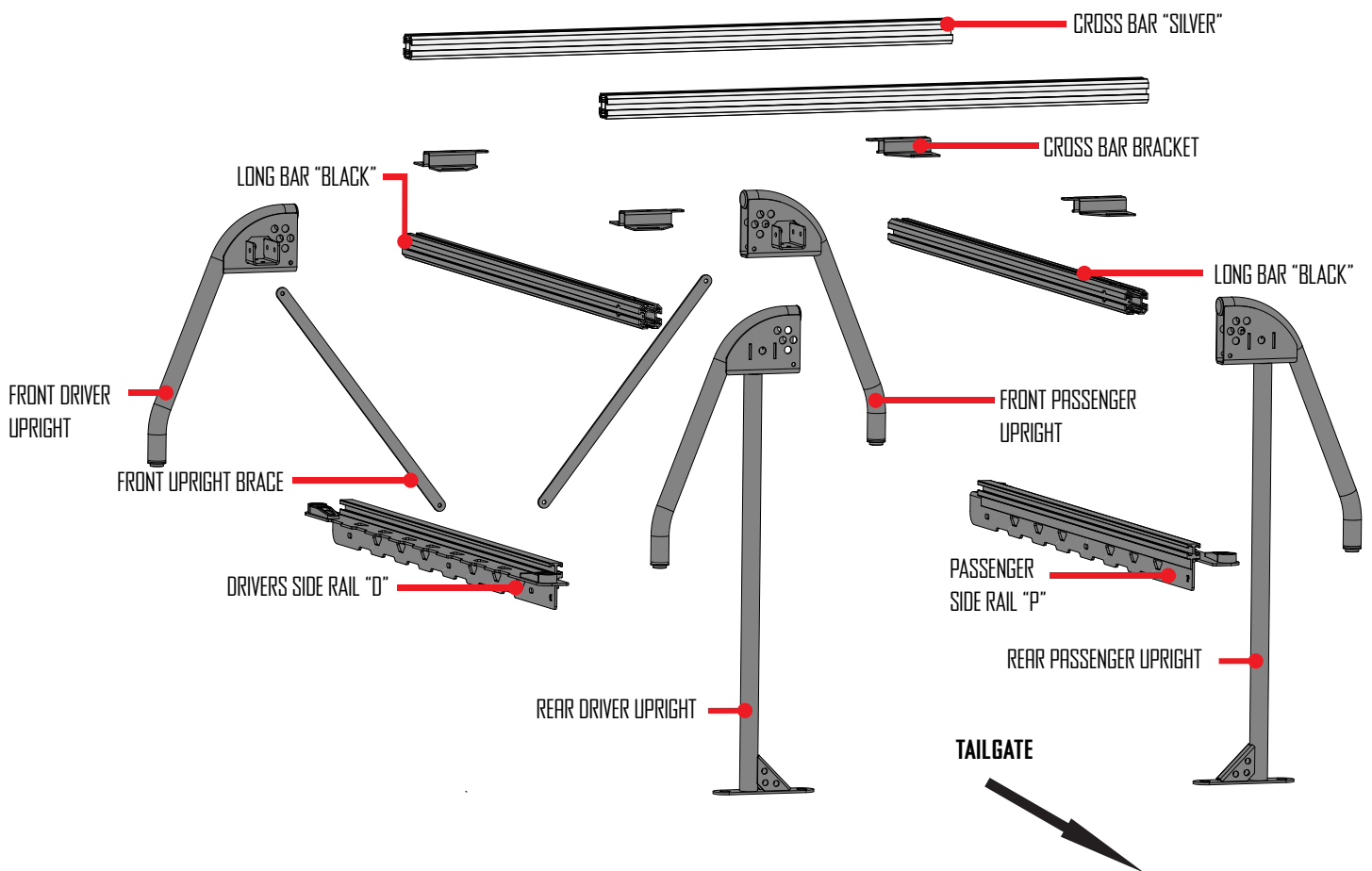

▼ ACTIVE CARGO SYSTEM HARDWARE ▼

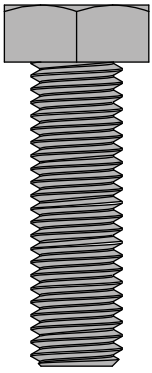

M12 X 40
(X4)

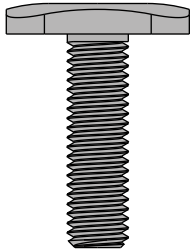

RAIL BOLT
(X6)

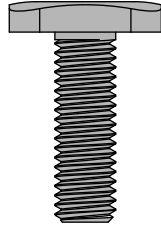

M8 T-BOLT
(X32)

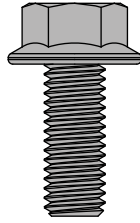

M8 X 20
(X2)

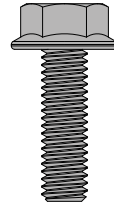

M6 X 20
(X2)

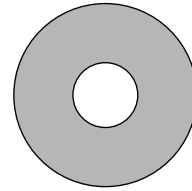

M8 WASHER
(X6)

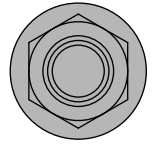

M8 NUT
(X36)

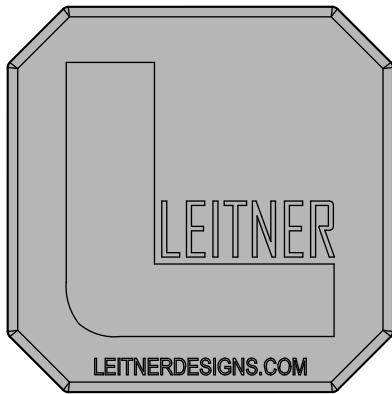

ENDCAP
(X4)

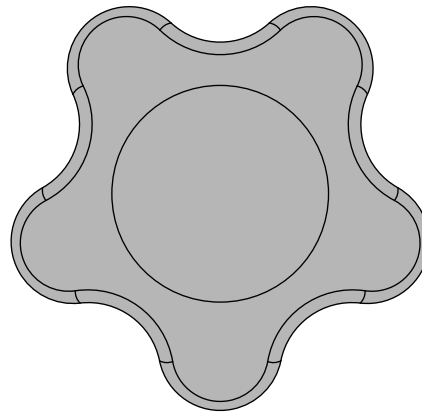

KNOB
(X4)

PREP FRONT UPRIGHTS: INSTALL BOLTS

- INSTALL 4 T-BOLTS INTO EACH UPRIGHT AS SHOWN.
- INSTALL A M8 LOCK NUT ON THE END OF EACH T-BOLT BY HAND UNTIL THEY STOP
- TO INSTALL THE NUT ON THE LOWER T-BOLT YOU WILL NEED TO USE THE ACCESS HOLE. PUTTING THE NUT ON THE END OF A 13MM DEEP SOCKET WILL ASSIST IN INSTALLATION.
- REPEAT STEPS BELOW FOR BOTH FRONT UPRIGHTS.

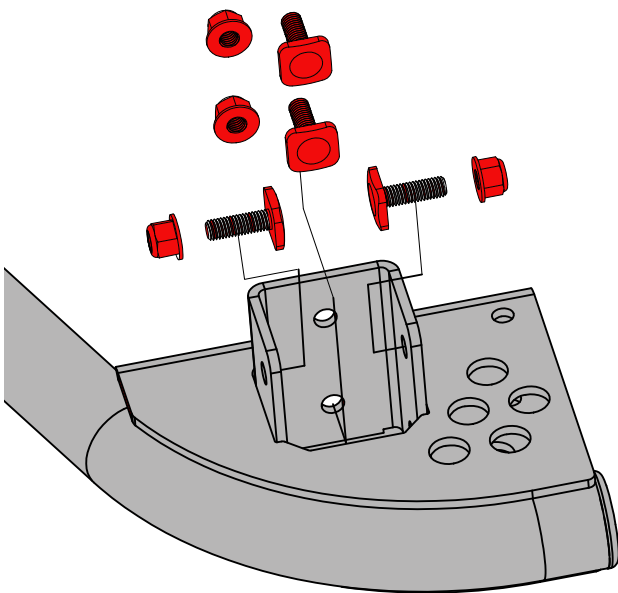

STEP 1

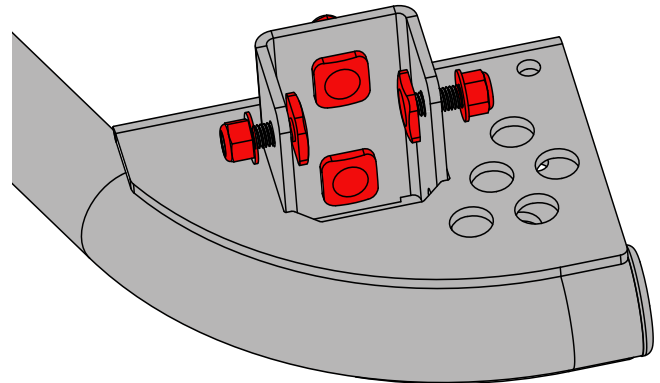

STEP 2

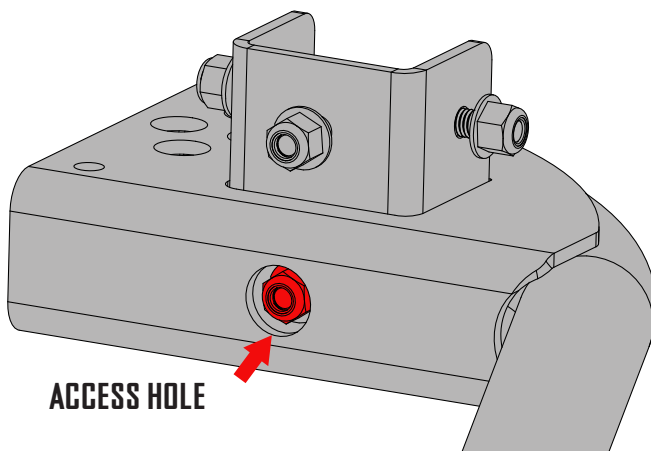

ACCESS HOLE

PREP REAR UPRIGHTS: INSTALL BOLTS

- INSTALL 4 T-BOLTS INTO EACH UPRIGHT AS SHOWN.
- INSTALL A M8 LOCK NUT ON THE END OF EACH T-BOLT BY HAND UNTIL THEY STOP
- REPEAT STEPS BELOW FOR BOTH REAR UPRIGHTS

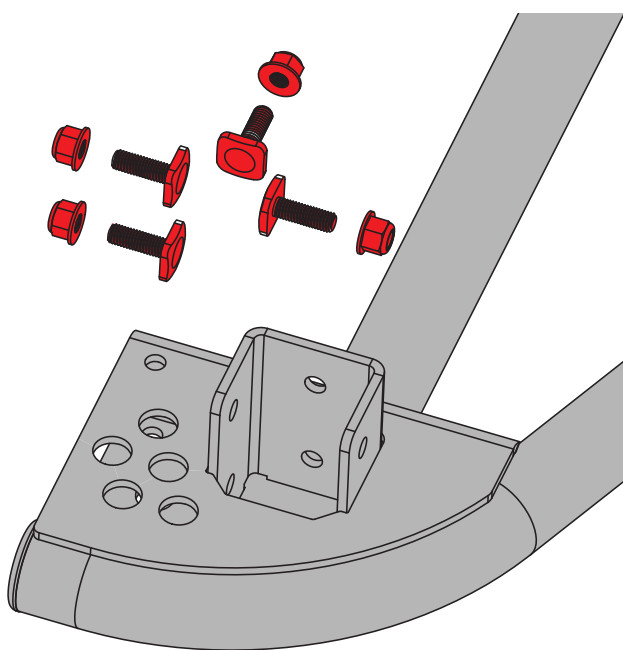

STEP 1

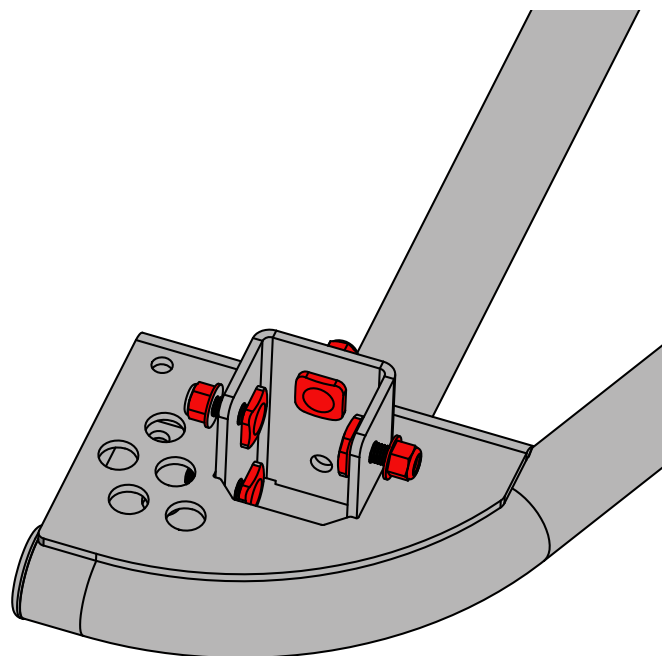

STEP 2

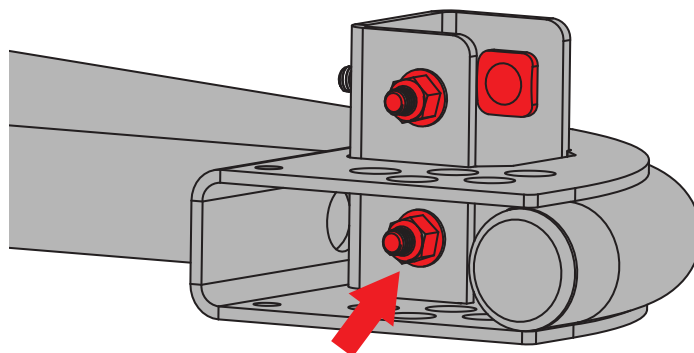

PREP: CROSS BAR BRACKETS

- INSTALL 2 T-BOLTS INTO EACH OF THE 4 CROSS BAR BRACKETS AS SHOWN BELOW.
- INSTALL AN M8 LOCK NUT ON THE END OF EACH T-BOLT BY HAND UNTIL THEY STOP
- REPEAT STEPS BELOW FOR ALL FOUR CROSS BAR BRACKETS.

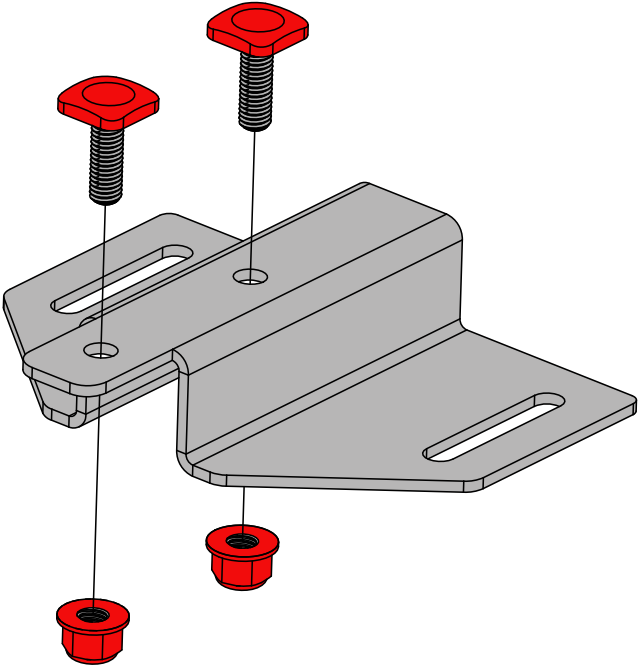

STEP 1

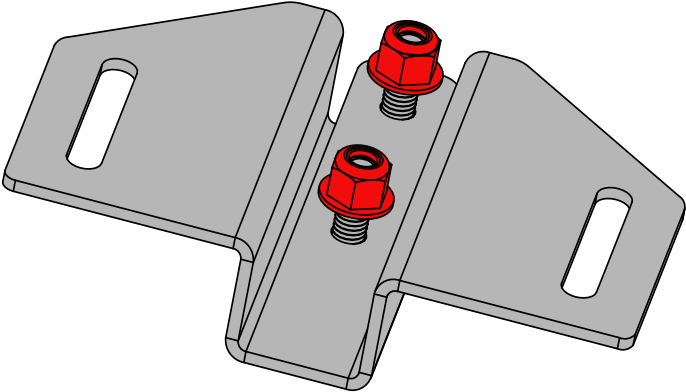

STEP 2

ASSEMBLE: DRIVERS SIDE

• INSTALL LONG BAR INTO A AND B UPRIGHT. HAVE A FRIEND ADJUST THE T-BOLT ORIENTATION TO LINE UP WITH THE SLOTS AS YOU INSERT THE LONG BAR INTO THE UPRIGHT. TIGHTEN THE FOUR M8 NUTS ON EACH UPRIGHT.

• USING TWO 12MM BOLTS FASTEN THE DRIVERS SIDE LOWER RAIL ONTO THE UPRIGHTS. TIGHTEN THE TWO 12MM BOLTS.

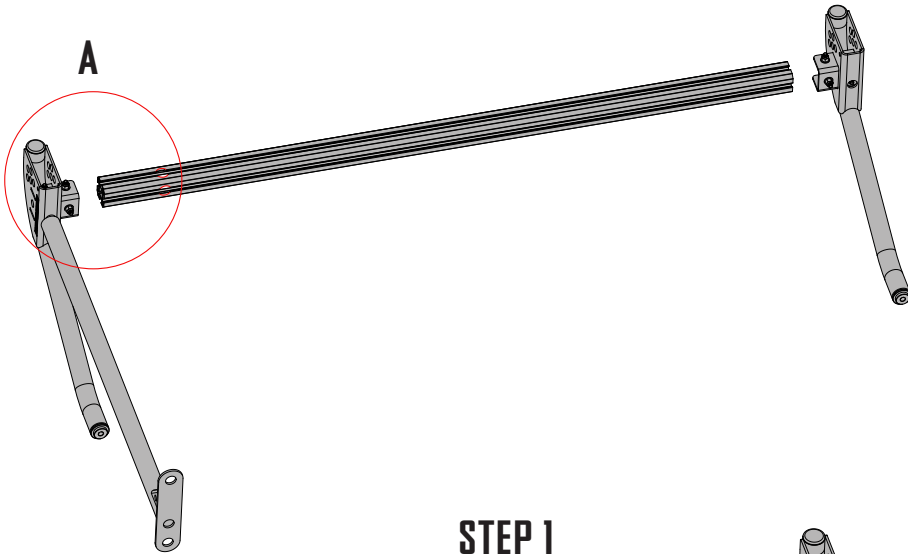

STEP 1

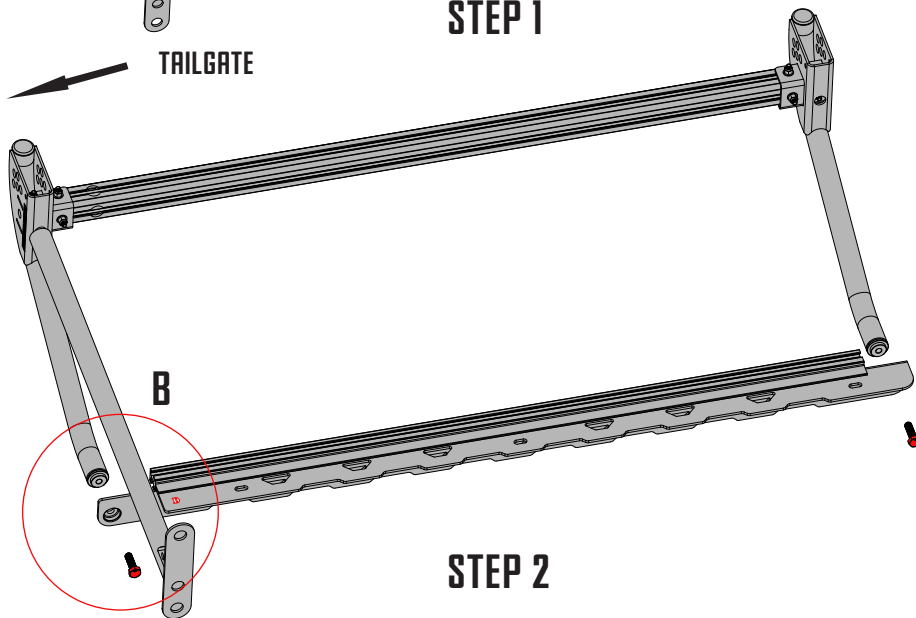
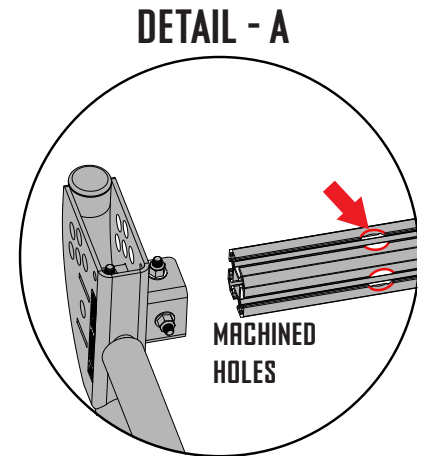

STEP 2

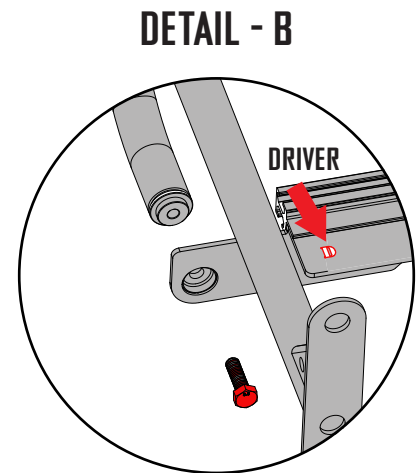

NOTE: MAKE SURE THAT THE LONG BAR TOUCHES THE BACK OF THE BACK UPRIGHT!! IF THIS IS NOT DONE YOU WILL NOT BE ABLE TO INSTALL THE LOWER RAIL WITHOUT BENDING PARTS!

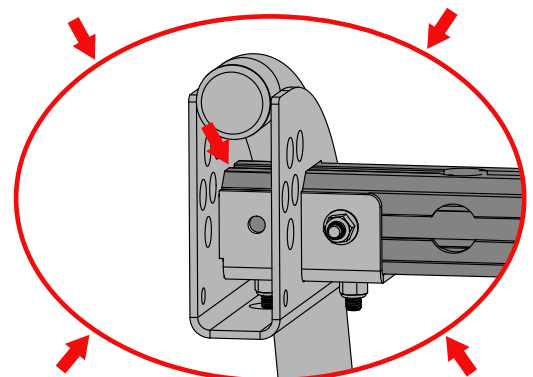

ASSEMBLE: PASSENGER SIDE

• INSTALL LONG BAR INTO A AND B UPRIGHT. HAVE A FRIEND ADJUST THE T-BOLT ORIENTATION TO LINE UP WITH THE SLOTS AS YOU INSERT THE LONG BAR INTO THE UPRIGHT. TIGHTEN THE FOUR M8 NUTS ON EACH UPRIGHT.

• USING TWO 12MM BOLTS FASTEN THE DRIVERS PASSENGER LOWER RAIL ONTO THE UPRIGHTS. TIGHTEN THE TWO 12MM BOLTS.

DETAIL - A

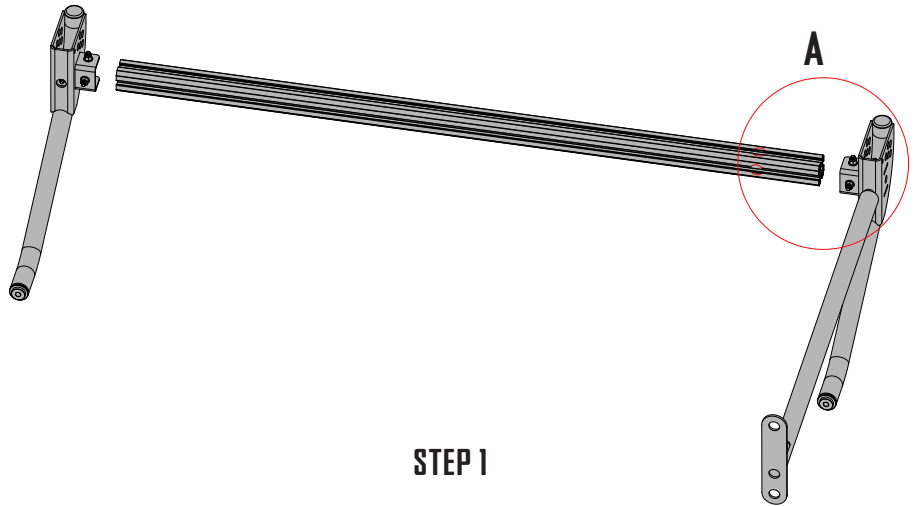
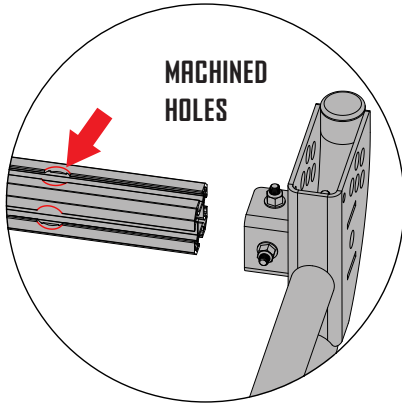

TAILGATE

DETAIL - B

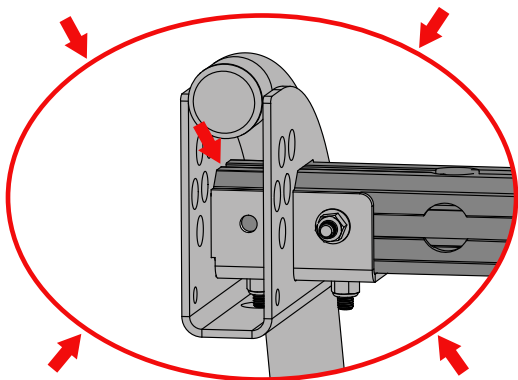
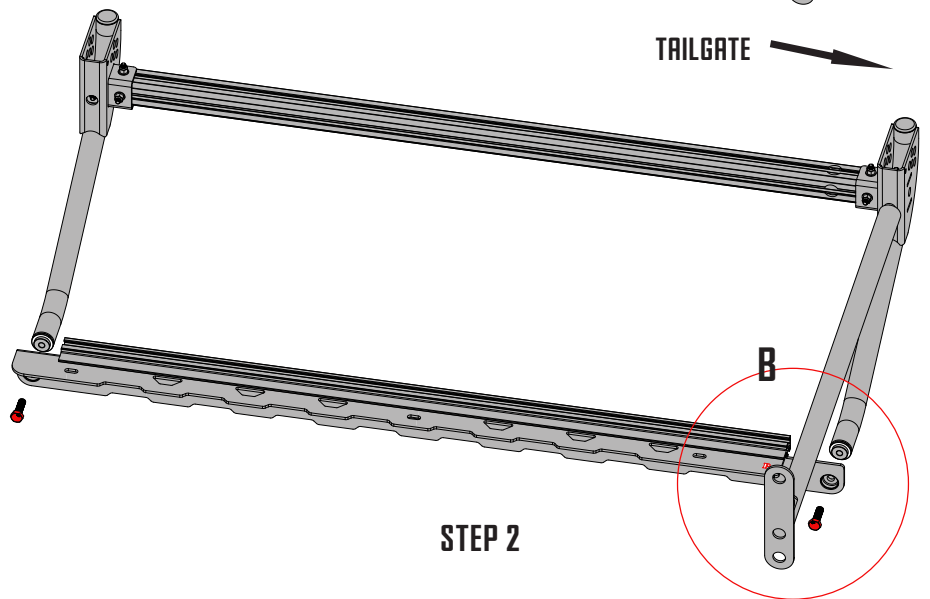
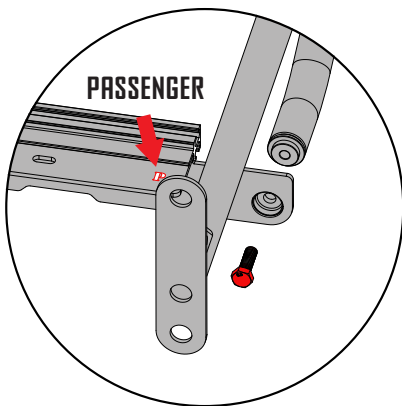

NOTE: MAKE SURE THAT THE LONG BAR TOUCHES THE BACK OF THE BACK UPRIGHT!! IF THIS IS NOT DONE YOU WILL NOT BE ABLE TO INSTALL THE LOWER RAIL WITHOUT BENDING PARTS!

PREP: TACOMA BED

- INSTALL THREE RAIL BOLTS INTO BOTH THE PASSENGER AND DRIVERS SIDE RAILS. (DETAIL - A)
- REMOVE BOTH THE PASSENGER AND DRIVERS SIDE THE BED BOLTS AND TIE-DOWNS FROM THE REAR OF THE BED USING THE SUPPLIED TORX WRENCHES. (DETAIL - B)

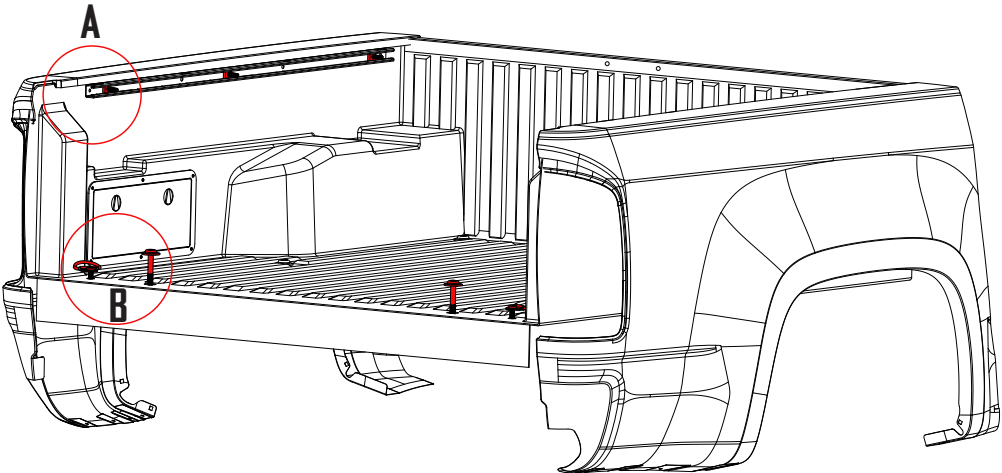

DETAIL - A

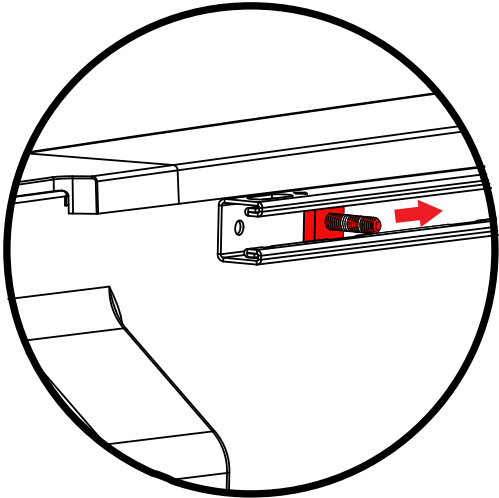

DETAIL - B

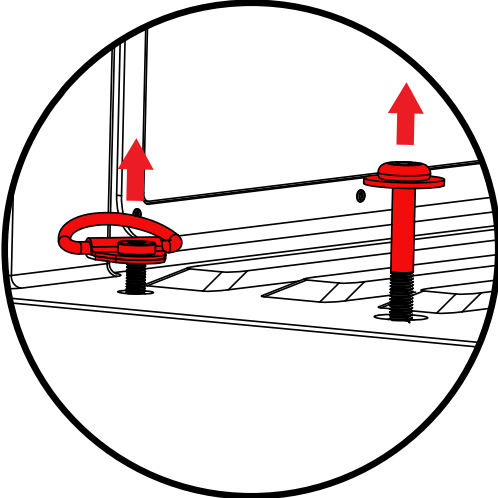

INSTALL: RACK TO TRUCK

- PLACE THE DRIVERS SIDE ASSEMBLY ONTO THE BED RAIL OF THE TRUCK. THE "D" WILL BE TOWARD THE TAILGATE. ALIGN THE THREE RAIL BOLTS WITH THE OVAL HOLES IN THE LOWER RAIL.
- USING A WASHER AND M8 BOLT LOOSELY ATTACH THE ASSEMBLY TO THE TRUCK. **[DETAIL - A]**
- REINSTALL THE TIE DOWN AND BED BOLTS THROUGH THE BRACKETS IN THE RACK AND TIGHTEN. **[DETAIL - B]**
- TIGHTEN THE 3 M8 BOLTS IN DETAIL - A. REPEAT STEPS FOR PASSENGER SIDE.
- REPEAT STEPS FOR PASSENGER SIDE.

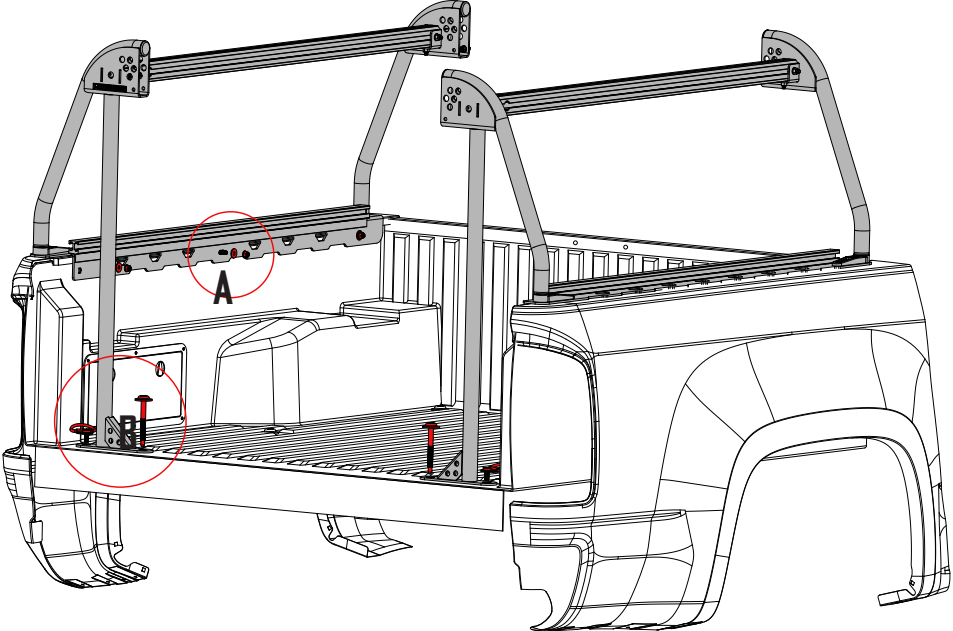

DETAIL - A

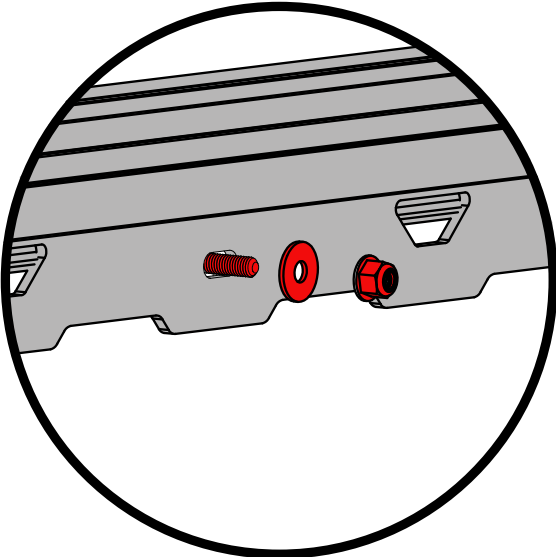

DETAIL - B

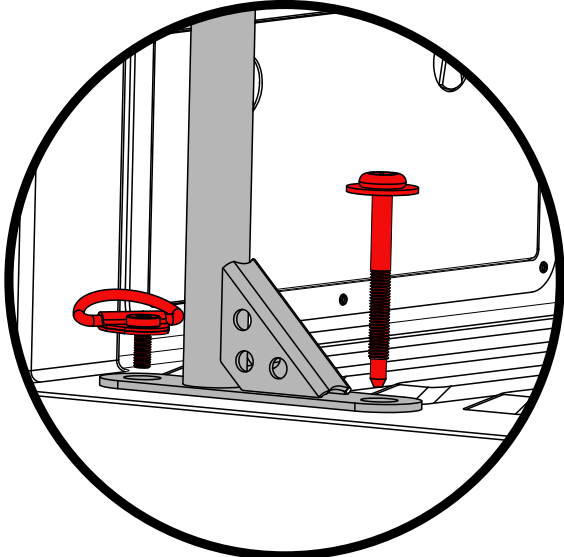

ASSEMBLE: FRONT UPRIGHT BRACE

• USING ONE M8 X 20 BOLT AND ONE M8 LOCK NUTS ATTACH FRONT UPRIGHT BRACE TO FRONT UPRIGHT. REPEAT FOR OTHER SIDE.
[**DETAIL-A**] SNUG BOLTS SO THAT THE BRACKET CAN STILL BE MOVED WITH SOME FORCE. THIS WILL HELP HOLD THINGS IN PLACE FOR THE NEXT FEW STEPS.

• FASTEN THE OTHER END OF THE UPRIGHT BRACE TO THE TWO THREADED INSERTS IN THE FRONT OF TRUCK BED USING M6 X 20 BOLTS. [**DETAIL-B**]

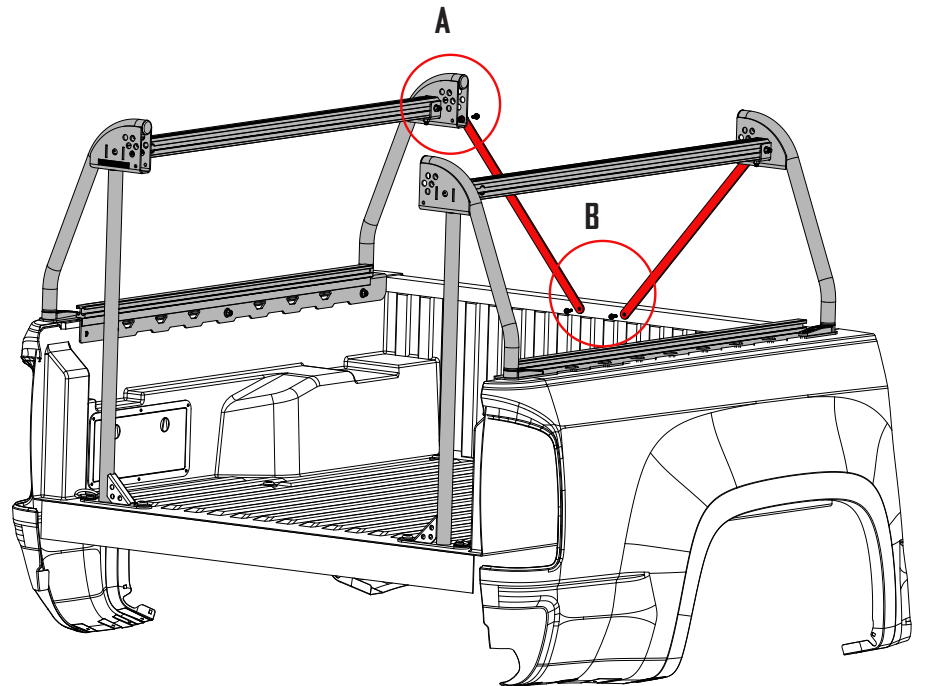

DETAIL - A

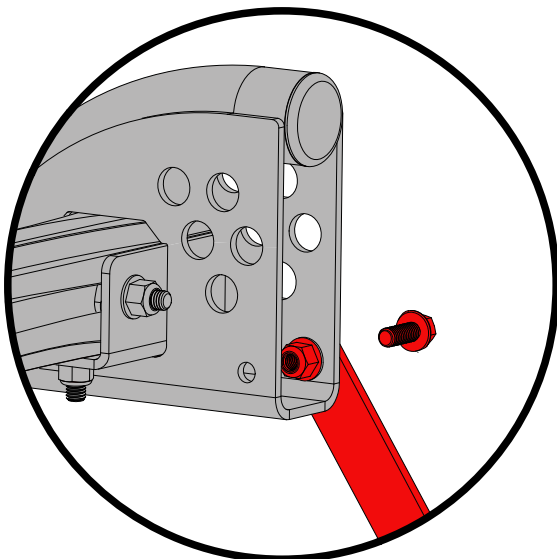

DETAIL - B

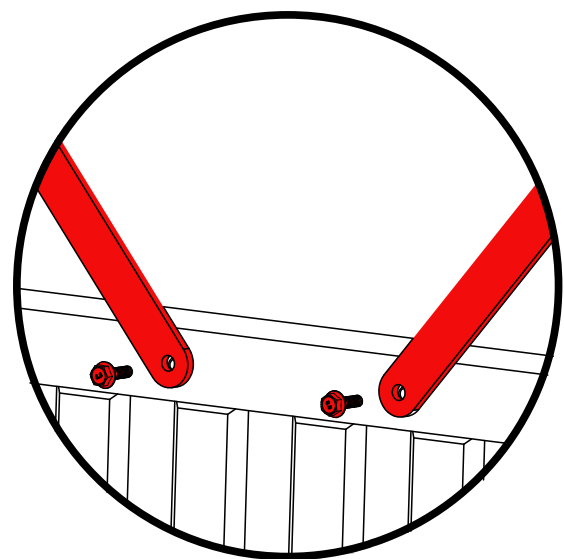

ASSEMBLE: CROSS BAR BRACKETS

- SLIDE 4 T-BOLTS INTO EACH T-TRACK ON THE TOP OF THE RACK USING THE ACCESS HOLES TOWARD THE BACK OF THE TRUCK.
- USING TWO M8 LOCK NUTS PER SIDE, SECURE THE FRONT CROSS BAR BRACKET AS FAR FORWARD AS POSSIBLE. [DETAIL -A] **NOTE: PUSHING THE FLAT EDGE OF THE CROSS BAR BRACKET AGAINST THE UPRIGHT WILL INSURE THAT THEY ARE PARALLEL.**
- USING 2 RUBBER KNOBS PER SIDE, SECURE THE REAR CROSS BAR BRACKET AS FAR REARWARD AS POSSIBLE. [DETAIL - B]

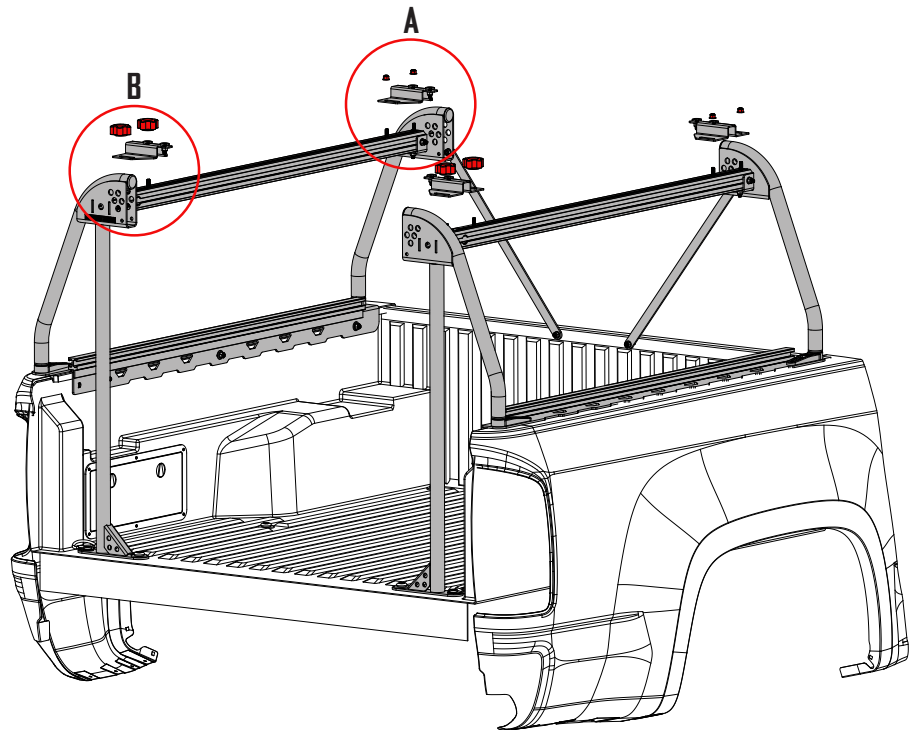

DETAIL - A

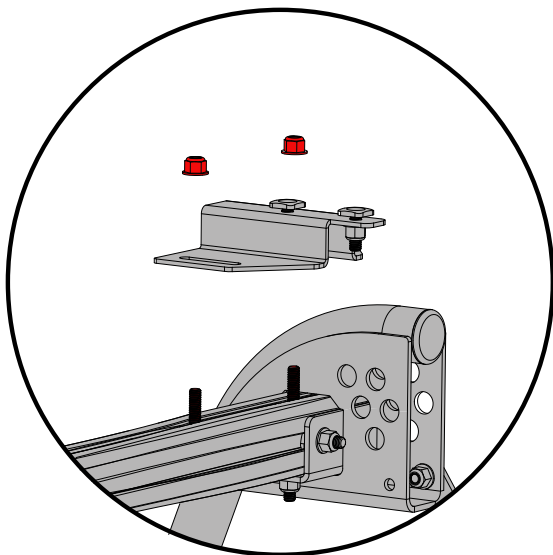

DETAIL - B

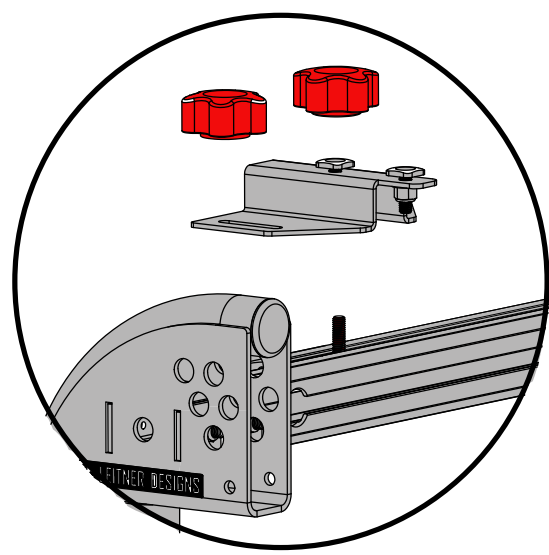

ASSEMBLE: CROSS BARS TO BRACKETS

• SLIDE THE SILVER CROSS BARS ONTO THE T-BOLTS IN THE CROSS BAR BRACKETS AND CENTER THEM ON THE RACK. TIGHTEN THE 2 T-BOLTS ON THE UNDERSIDE OF EACH BRACKET

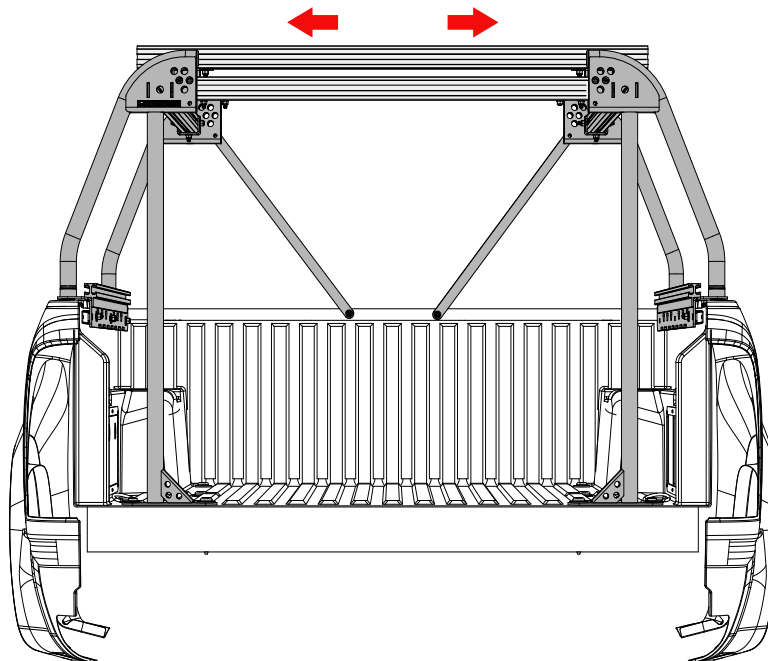
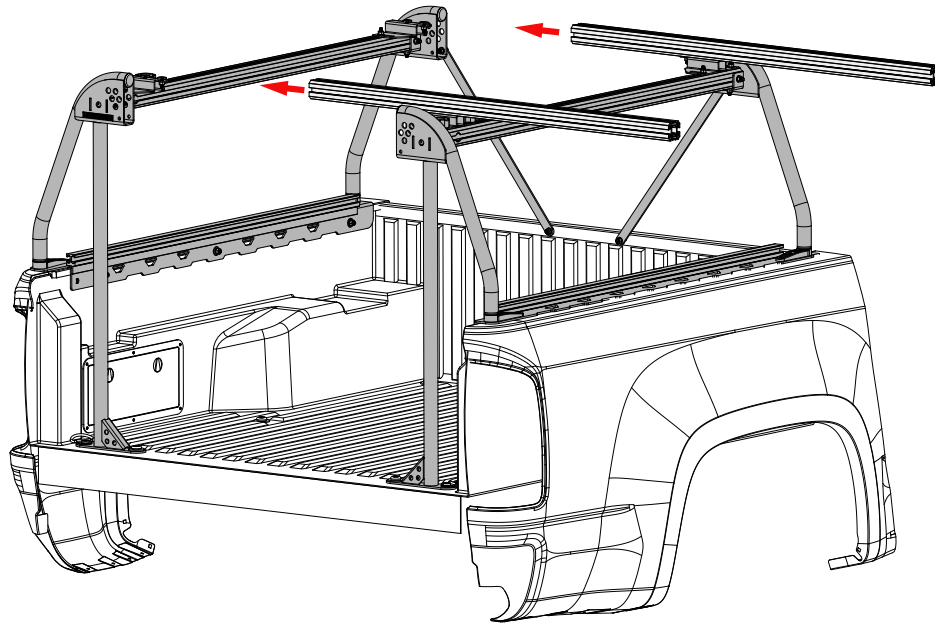

FINISH: INSTALL END CAPS AND RUBBER TREAD STRIP

- INSTALL THE RUBBER TREAD STRIP INTO THE UPPER CROSS BAR CHANNEL BY PUSHING IT INTO THE T-SLOT WITH THE PALM OF YOUR HAND. NOTE: SOME TRIMMING OF THE RUBBER TREAD STRIP MIGHT BE NECESSARY.
- INSTALL THE FOUR END CAPS INTO THE ENDS OF THE CROSS BARS.

! CHECK ALL FASTENERS INSTALLED IN PREVIOUS STEPS TO ENSURE THEY ARE PROPERLY TIGHTENED !

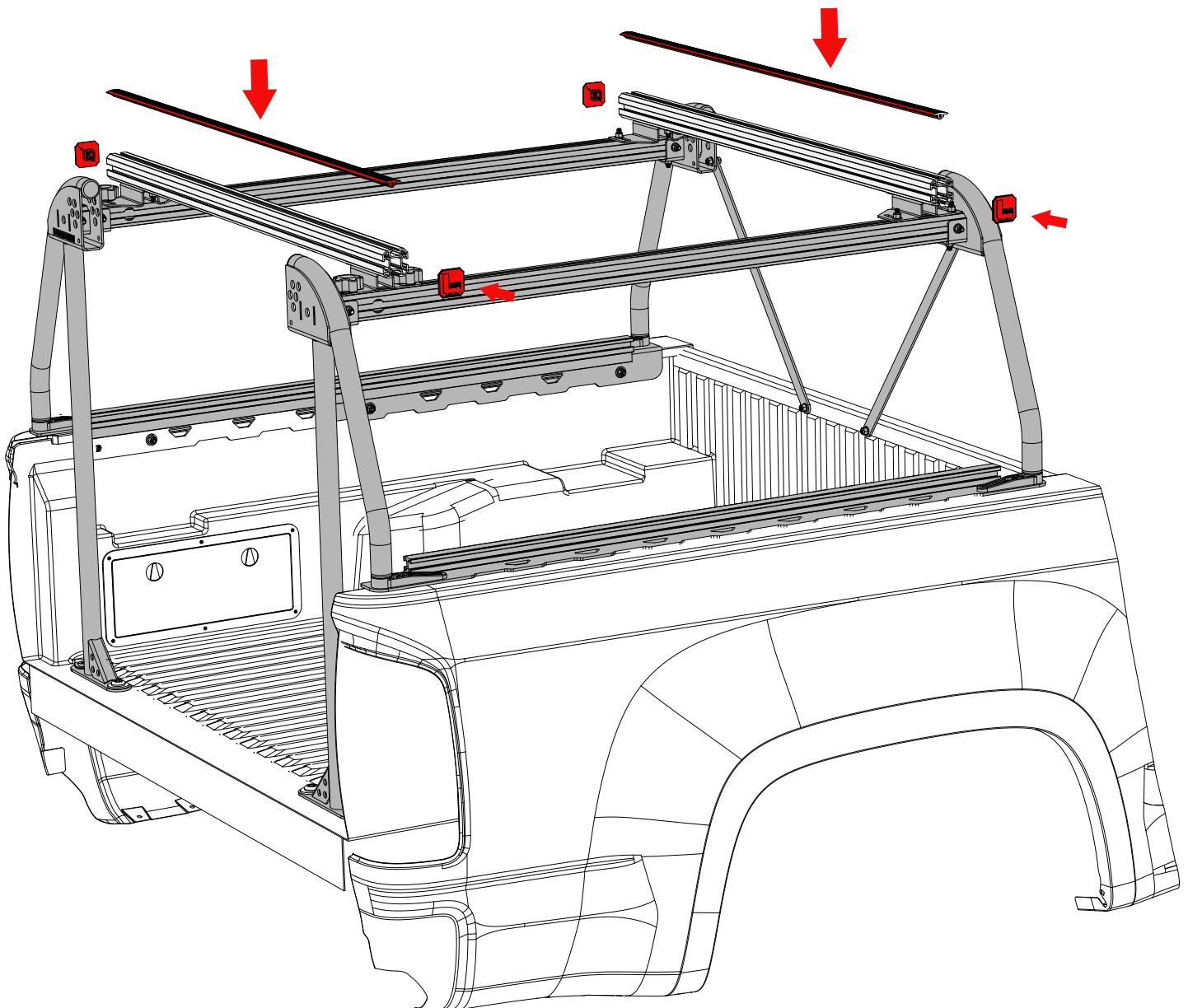

USE GUIDELINES

WHEN USING LEITNER DESIGNS CARRIERS AND ACCESSORIES, THE USER MUST UNDERSTAND THE PRECAUTIONS. THE POINTS LISTED BELOW WILL ASSIST YOU IN USING THE RACK SYSTEM AND WILL ENCOURAGE SAFETY.

-FOR QUALITY FITS AND SAFETY, USE ONLY THE RECOMMENDED RACK OR ACCESSORIES. DO NOT ASSUME A RACK WILL FIT, ALWAYS CHECK THE CURRENT FIT GUIDE WHEN OBTAINING A NEW VEHICLE.

-THE MAXIMUM LOAD IS NOT TO BE EXCEEDED. (250# OFF ROAD – 500# ON ROAD). HOWEVER, THIS LIMIT IS ALWAYS SUBORDINATE TO THE MAXIMUM LOAD RECOMMENDED BY THE MANUFACTURER OF THE VEHICLE ITSELF. IT IS ALWAYS THE LOWER MAXIMUM RECOMMENDED LOAD THAT APPLIES. MAX TRUCK LOAD = LOAD CARRIER WEIGHT + ANY FITTED CARRIER ACCESSORIES + THE WEIGHT OF THE LOAD ITSELF.

-HIGH SPEED OFF ROAD DRIVING EVEN WITH A LIGHT LOAD CAN CAUSE DAMAGE TO THE RACK, ACCESSORIES AND VEHICLE BODY. DAMAGE CAUSED BY HIGH SPEED OFF ROAD DRIVING AND ABUSE IS NOT COVERED UNDER WARRANTY.

-MAKE SURE ALL KNOBS, BOLTS, SCREWS, STRAPS, AND LOCKS ARE FIRMLY ATTACHED, TIGHTENED AND LOCKED BEFORE EVERY TRIP. KNOBS, BOLTS, SCREWS, STRAPS AND LOCKS MUST BE PERIODICALLY INSPECTED FOR SIGNS OF WEAR, CORROSION, AND FATIGUE. CHECK YOUR LOAD AT STOPS DURING THE TRIP TO ENSURE CONTINUED FASTENING SECURITY.

-CHECK LOCAL AND STATE LAWS GOVERNING PROJECTION OF OBJECTS BEYOND THE PERIMETER OF A VEHICLE. BE AWARE OF THE WIDTH AND HEIGHT OF YOUR CARGO SINCE LOW CLEARANCE BRANCHES, BRIDGES, AND PARKING GARAGES CAN AFFECT THE LOAD. ALL CARGO WILL AFFECT THE VEHICLE'S DRIVING BEHAVIOR. NEVER DRIVE WITH ANY LOCK, KNOB OR RACK IN AN OPEN OR UNLOCKED POSITION. ALL LONG LOADS SUCH AS, BUT NOT LIMITED TO, SAILBOARDS, SURFBOARDS, KAYAKS, CANOES, AND LUMBER MUST BE TIED DOWN FRONT AND REAR TO THE BUMPERS OR TOW HOOKS OF THE VEHICLE.

-ALL LOCKS MUST BE TURNED AND MOVED PERIODICALLY TO ENSURE SMOOTH OPERATION. USE GRAPHITE OR DRY LUBRICANT TO HELP THIS. LEITNER DESIGNS LOCKS ARE DESIGNED TO DETER VANDALISM AND THEFT BUT SHOULD NOT BE CONSIDERED THEFT PROOF. REMOVE VALUABLE GEAR IF YOUR VEHICLE IS UNATTENDED FOR AN EXTENDED PERIOD. PLACE AT LEAST ONE KEY IN THE GLOVE COMPARTMENT.

-FOR SAFETY TO YOUR VEHICLE AND RACK SYSTEM, OBEY ALL POSTED SPEED LIMITS AND TRAFFIC CAUTIONS. ADAPT YOUR SPEED TO THE CONDITIONS OF THE ROAD AND THE LOAD BEING CARRIED.

-DO NOT USE LEITNER DESIGNS LOAD CARRIERS AND ACCESSORIES FOR PURPOSES OTHER THAN THOSE FOR WHICH THEY WERE DESIGNED. DO NOT EXCEED THEIR CARRYING CAPACITY. FAILURE TO FOLLOW THESE GUIDELINES OR THE PRODUCT'S INSTRUCTIONS WILL VOID THE WARRANTY.

WARRANTY

LEITNER DESIGNS WARRANTS PRODUCT TO BE FREE FROM DEFECTS IN MATERIAL AND WORKMANSHIP, FOR TERMS SPECIFIED BELOW, PROVIDED THERE HAS BEEN NORMAL USE AND PROPER MAINTENANCE. ALL REMEDIES UNDER THIS WARRANTY ARE LIMITED TO THE REPAIR OR REPLACEMENT OF ANY ITEM FOUND BY THE FACTORY TO BE DEFECTIVE WITHIN THE TIME PERIOD SPECIFIED. IF YOU HAVE A WARRANTY CLAIM, FIRST YOU MUST CALL OUR FACTORY AT THE NUMBER BELOW FOR INSTRUCTIONS. YOU MUST RETAIN PROOF OF PURCHASE AND SUBMIT A COPY WITH ANY ITEMS RETURNED FOR WARRANTY WORK. UPON COMPLETION OF WARRANTY WORK, IF ANY, WE WILL RETURN THE REPAIRED OR REPLACED ITEM OR ITEMS TO YOU FREIGHT PREPAID. DAMAGE TO OUR PRODUCTS CAUSED BY ACCIDENTS, FIRE, VANDALISM, NEGLIGENCE, MIS-INSTALLATION, MISUSE, ACTS OF GOD, OR BY DEFECTIVE PARTS NOT MANUFACTURED BY US, IS NOT COVERED UNDER THIS WARRANTY.

THE WARRANTY TIME PERIOD IS AS FOLLOWS: (2) TWO YEARS FROM DATE OF PURCHASE.

HIGH SPEED OFF ROAD DRIVING EVEN WITH A LIGHT LOAD CAN CAUSE DAMAGE TO THE RACK, ACCESSORIES AND VEHICLE BODY. DAMAGE CAUSED BY HIGH SPEED OFF ROAD DRIVING AND ABUSE IS NOT COVERED UNDER WARRANTY.

ANY IMPLIED WARRANTIES OF MERCHANTABILITY AND/OR FITNESS FOR A PARTICULAR PURPOSE CREATED HEREBY ARE LIMITED IN DURATION TO THE SAME DURATION AND SCOPE AS THE EXPRESS WRITTEN WARRANTY. OUR COMPANY SHALL NOT BE LIABLE FOR ANY INCIDENTAL OR CONSEQUENTIAL DAMAGE.

SOME STATES DO NOT ALLOW LIMITATIONS ON HOW LONG AN IMPLIED WARRANTY LASTS, OR THE EXCLUSION OR LIMITATION OF INCIDENTAL OR CONSEQUENTIAL DAMAGES, SO THE ABOVE LIMITATIONS OR EXCLUSIONS MAY NOT APPLY TO YOU. THIS WARRANTY GIVES YOU SPECIFIC LEGAL RIGHTS, AND YOU MAY ALSO HAVE OTHER RIGHTS THAT VARY FROM STATE TO STATE.

FOR WARRANTY ISSUES WITH THIS PRODUCT PLEASE CALL LEITNER DESIGNS CUSTOMER SERVICE 949-395-3049 OR EMAIL US AT SALES@LEITNERDESIGNS.COM