

LEITNER

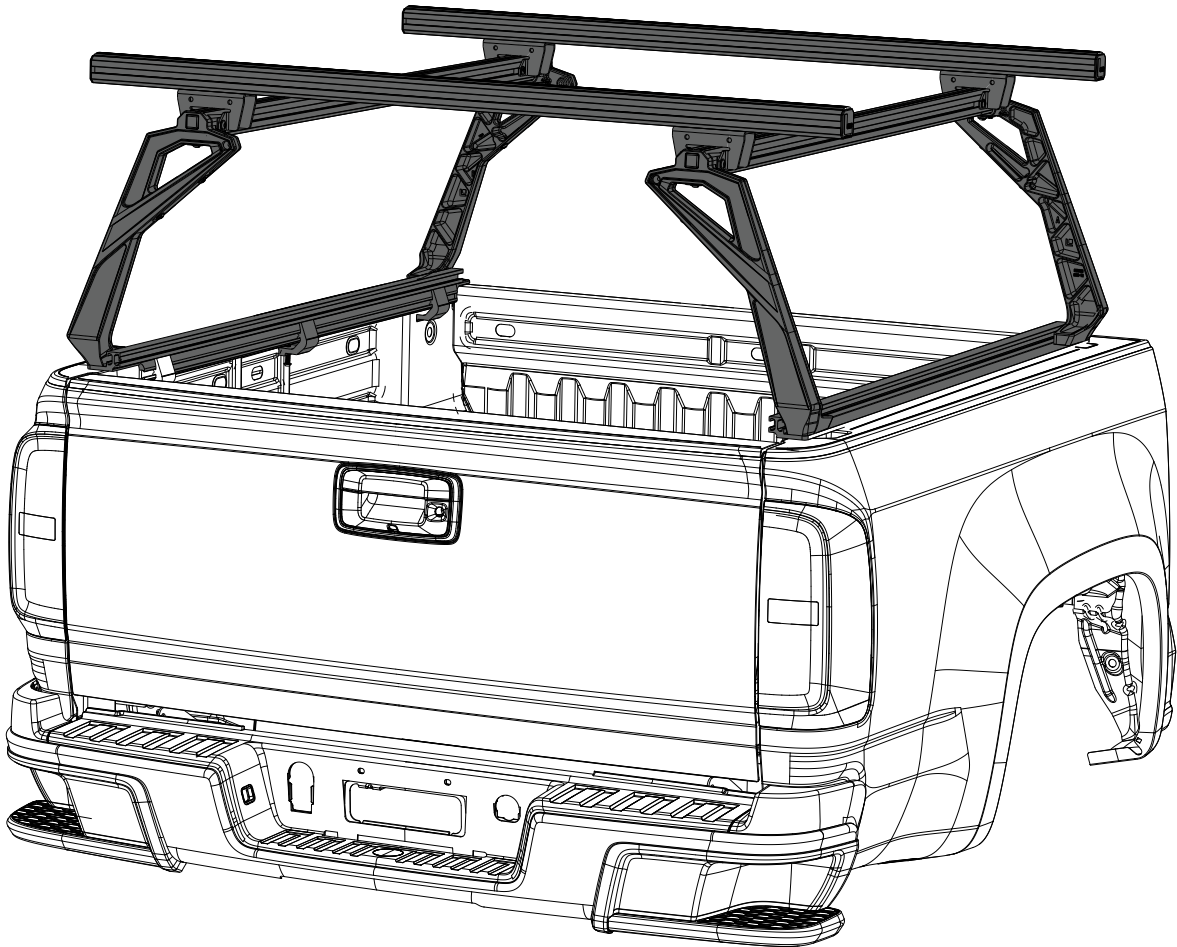

INTERNATIONAL

LEITNERDESIGNS.COM | SUPPORT@LEITNERDESIGNS.COM | 949-395-3049

ASSEMBLY / INSTALLATION INSTRUCTIONS:

ACTIVE CARGO SYSTEM PART NUMBERS:

00-50-FIN-1464 (1500MM - 5-0' BED LENGTH)

TOOLS REQUIRED

- TORQUE WRENCH
- T30 TORX BIT SOCKET
- T40 TORX BIT SOCKET
- 5MM ALLEN SOCKET

TOOLS INCLUDED

- T30 TORX WRENCH
- T40 TORX WRENCH

INSTALLATION TIME

2-3 HOURS

BASIC KNOWLEDGE OF HAND TOOLS REQUIRED

SKILL LEVEL



3= INTERMEDIATE

▼ READ BEFORE INSTALLING ACTIVE CARGO SYSTEM ▼

1. DON'T OVER-TIGHTEN BOLTS. ALL 10MM BOLTS = (55N.M) ALL 8MM BOLTS = (20N.M) ALL CLAMP BOLTS = (10N.M)
2. LAY DOWN A LARGE AREA OF CARPET OR BLANKETS AS A WORK AREA TO AVOID SCRATCHING PARTS DURING ASSEMBLY.
3. ALTHOUGH THE ACTIVE CARGO SYSTEM IS LIGHT HAVING A FRIEND TO HELP IS RECOMMENDED.

▼ ASSEMBLY OVERVIEW ▼

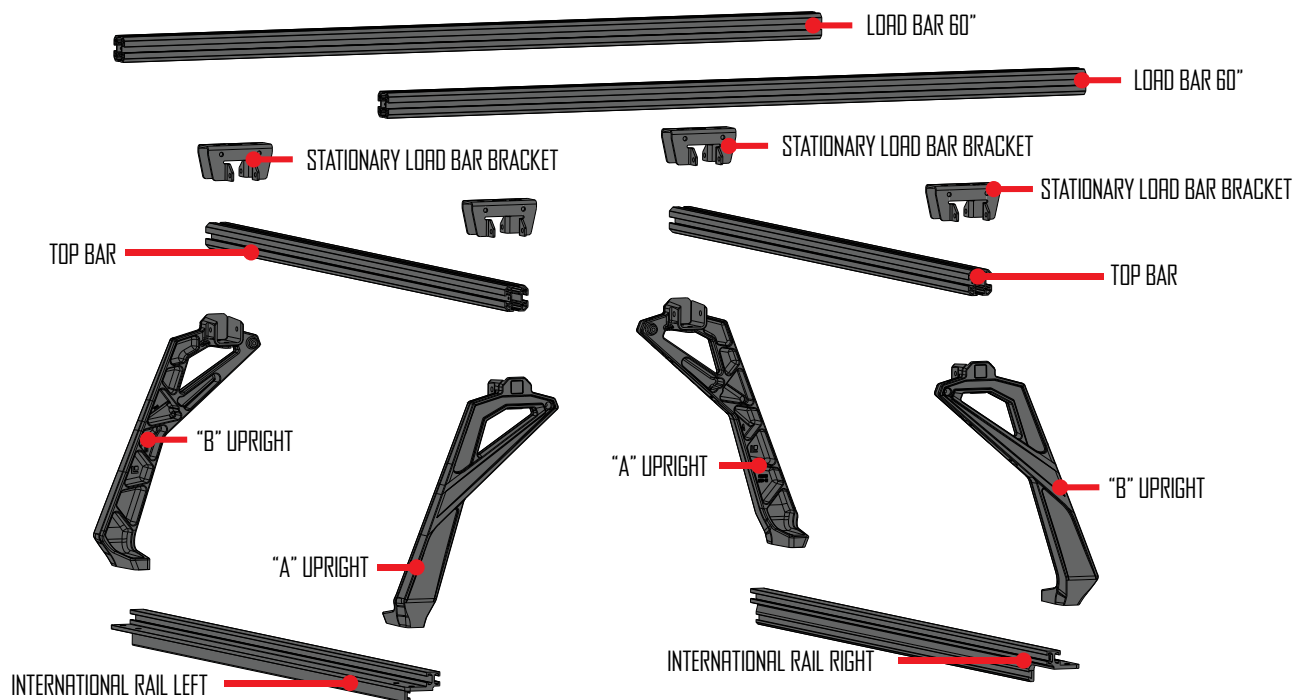

▼ ACTIVE CARGO SYSTEM HARDWARE ▼

LONG T-NUT
(X12)



SHORT T-NUT
(X4)



SINGLE T-NUT
(X4)

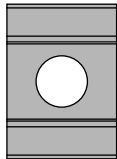

← NOT USED WITH INTERNATIONAL RACK

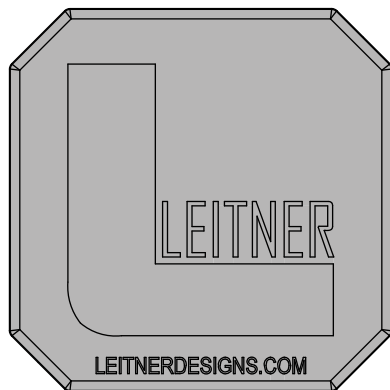

ENDCAP
(X4)

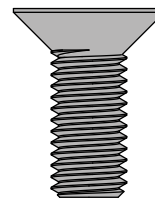

M10 X 22
(X8)

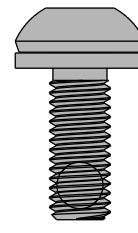

M8 X 20
(X16)

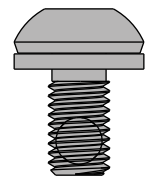

M8 X 14
(X16)

▼ ACTIVE CARGO SYSTEM RAIL CLAMP HARDWARE ▼



M8 X 60
(X6)

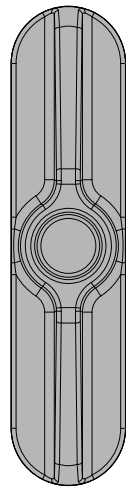

RAIL CLAMP SPACER
(X6)

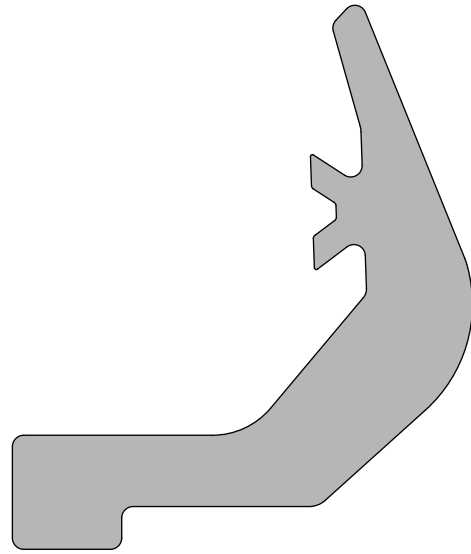

RAIL CLAMP
(X6)

PREP: LOAD BAR BRACKETS

- INSTALL 2 M8 X 14 BOLTS THROUGH BRACKET AND THREAD INTO LONG T-NUT. DO NOT TIGHTEN AT THIS TIME.
- REPEAT STEPS BELOW FOR ALL FOUR BRACKETS.
- SET ASIDE FOR USE IN A LATER STEP.

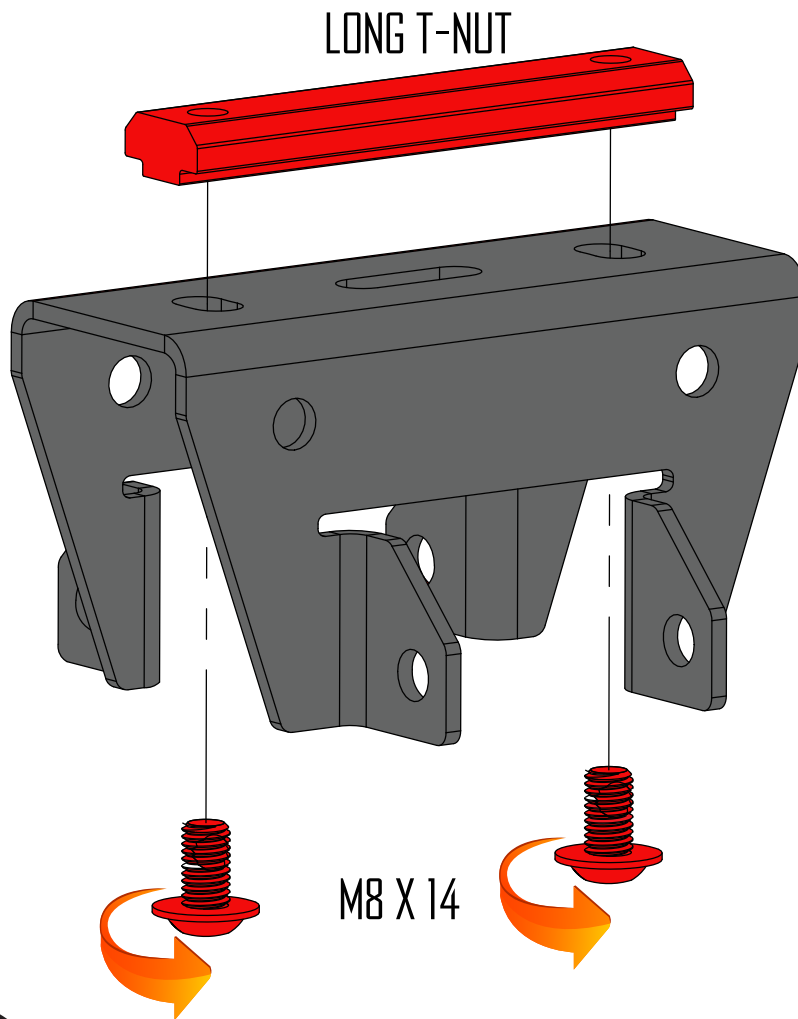

4X

ASSEMBLE: UPRIGHT "A"

- ASSEMBLE UPRIGHTS MARKED "A" AS SHOWN IN THE FOLLOWING DIAGRAM.
- THREAD TWO M8 X 20 BOLTS INTO THE SHORT T-NUT. {FIG-A} DO NOT TIGHTEN AT THIS TIME.
- THREAD TWO M8X 20 BOLTS THROUGH CROSS BAR BRACKET AND UPRIGHT INTO LONG T-NUT {FIG-B} DO NOT TIGHTEN AT THIS TIME.
- THREAD TWO M8X 16 BOLTS THROUGH CROSS BAR BRACKET INTO LONG T-NUT {FIG-B} DO NOT TIGHTEN AT THIS TIME.

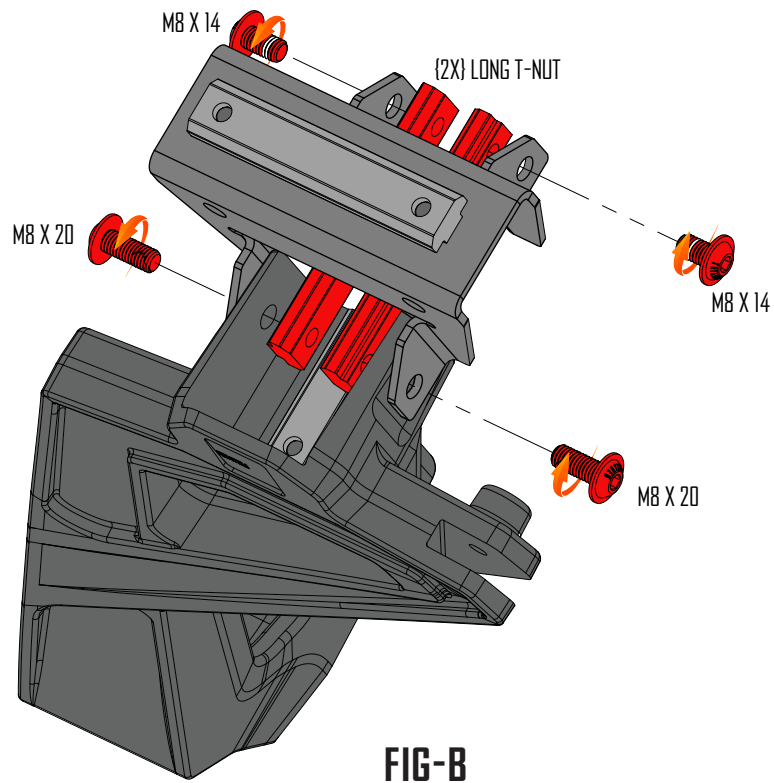
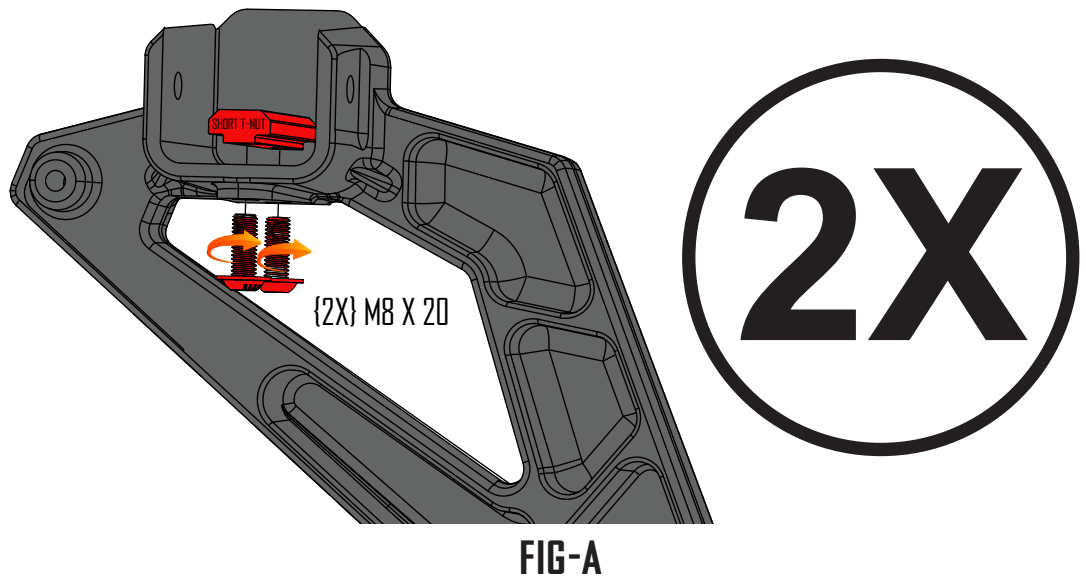

ASSEMBLE: UPRIGHT "B"

- ASSEMBLE UPRIGHTS AS SHOWN IN THE FOLLOWING DIAGRAM.
- THREAD TWO M8 X 20 BOLTS INTO THE SHORT T-NUT. (FIG-A) **DO NOT TIGHTEN AT THIS TIME.**
- THREAD TWO M8X 20 BOLTS THROUGH CROSS BAR BRACKET AND UPRIGHT INTO LONG T-NUT (FIG-B) **DO NOT TIGHTEN AT THIS TIME.**
- THREAD TWO M8X 16 BOLTS THROUGH CROSS BAR BRACKET INTO LONG T-NUT (FIG-B) **DO NOT TIGHTEN AT THIS TIME.**

2X

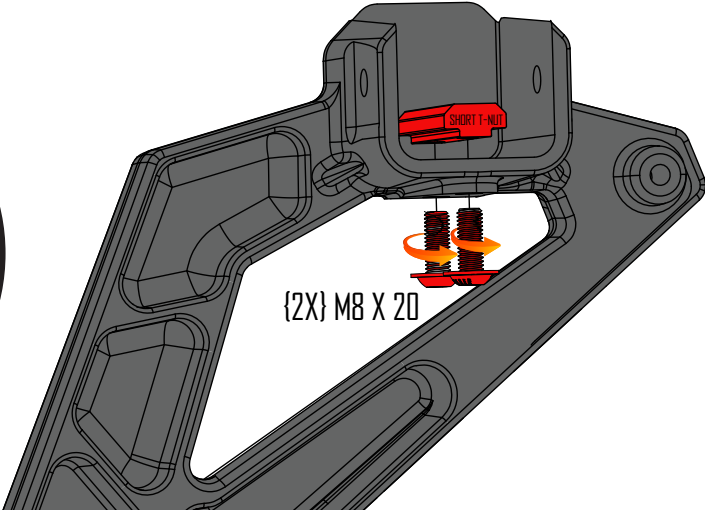

FIG-A

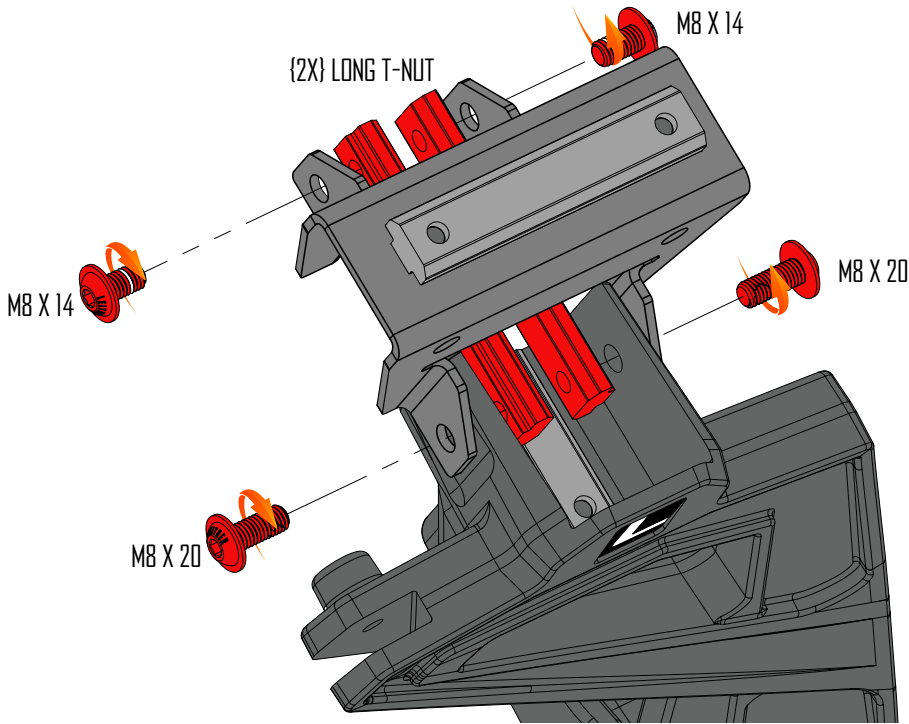
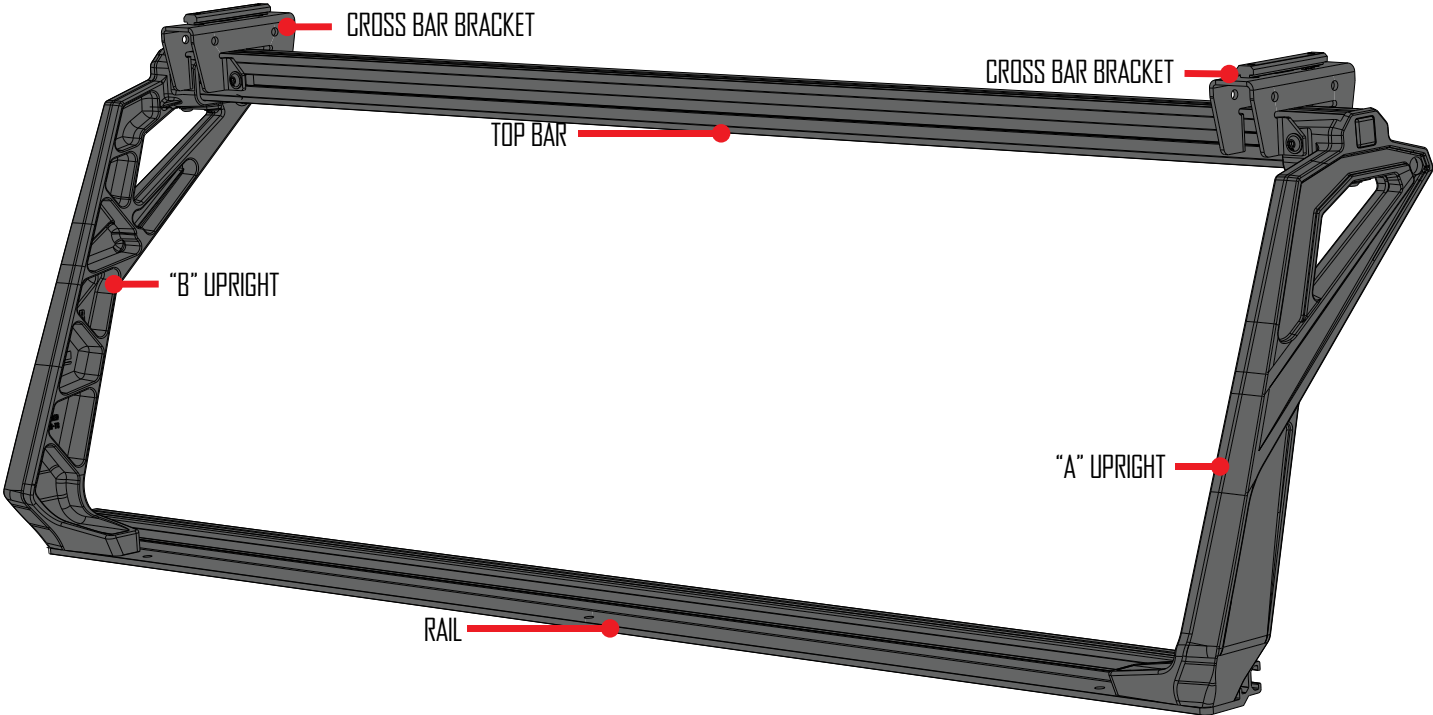

FIG-B

ASSEMBLE ACS SIDE: OVERVIEW

- IN THE NEXT FEW STEPS YOU WILL ASSEMBLE THE LEFT AND RIGHT SIDE PORTION OF THE ACTIVE CARGO SYSTEM.
- THE ILLUSTRATION BELLOW SHOWS WHAT THE PART WILL LOOK LIKE WHEN FULLY ASSEMBLED. YOU CAN REFER BACK TO THIS ILLUSTRATION AT ANY TIME TO CLARIFY PART LOCATION.



2X

ASSEMBLE: TOP BAR

- ATTACH A & B UPRIGHT ASSEMBLY'S TO TOP BAR AS SHOWN IN ILLUSTRATION BELOW.
- **DO NOT TIGHTEN THE M8 BOLTS AT THIS TIME.**

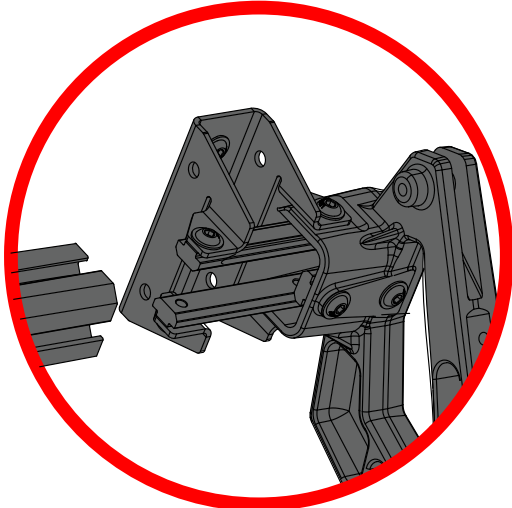
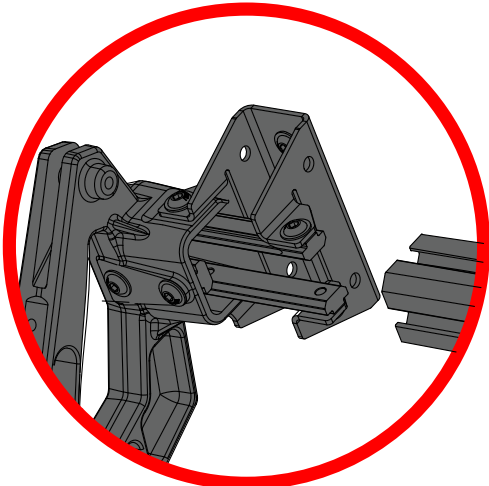

2X

ASSEMBLE: RAIL

- **NOTE: LEFT SIDE SHOWN. REPEAT STEPS FOR RIGHT SIDE ASSEMBLY.**
- ATTACH RAIL TO UPRIGHTS USING FOUR M10 X 25 SCREWS. TORQUE TO 50N.M USING A T40 TORX WRENCH.
- TORQUE ALL M8 BOLTS INSTALLED IN PREVIOUS STEP TO 20N.M USING A T40 TORX WRENCH.
- **IMPORTANT: TIGHTEN M10X25 RAIL BOLTS FIRST THEN TORQUE THE M8 BOLTS.**

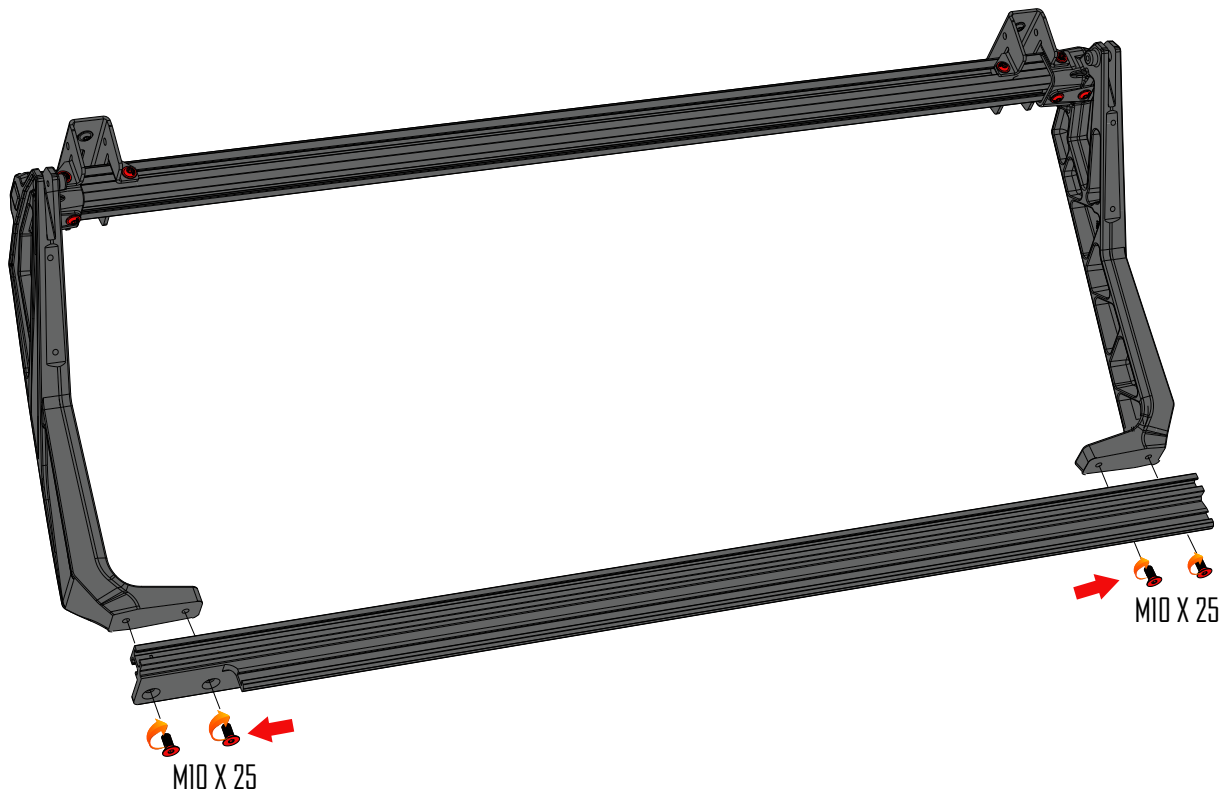

2X

ASSEMBLE: RAIL CLAMPS TO RAILS

• INSTALL THREE RAIL CLAMPS ONTO THE LEFT AND RIGHT SIDE RAIL THAT WERE ASSEMBLED IN PREVIOUS STEPS. THE RAIL CLAMP WILL SLIDE ONTO THE RAIL FROM EITHER END.

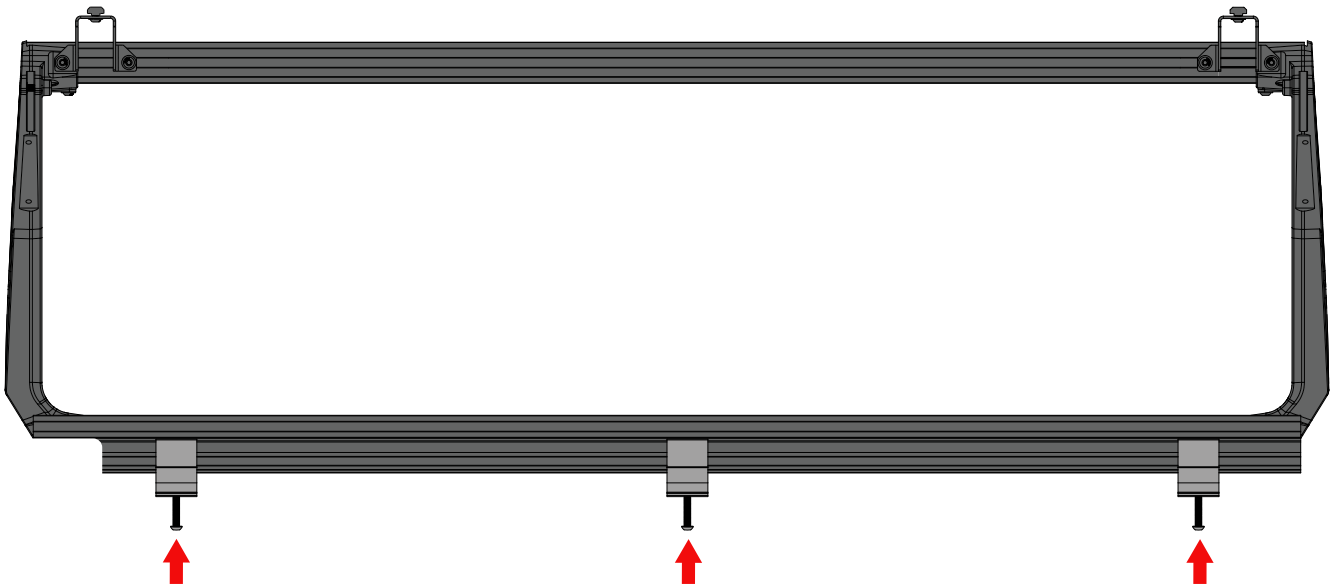
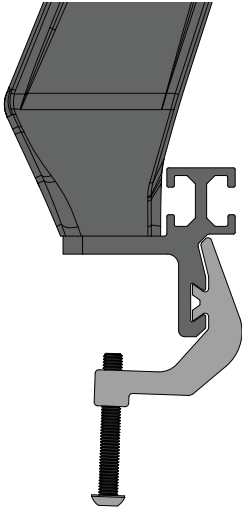

• NOTE: SOME TRUCK BEDS WILL NOT ALLOW THE CLAMPS TO BE SPACED EVENLY. IN THIS SITUATION IT MIGHT BE NECESSARY TO HAVE 2 CLAMPS NEXT TO EACH OTHER.

INSTALL: RACK TO TRUCK

- PLACE THE LEFT SIDE ASSEMBLY ONTO THE BED RAIL OF THE TRUCK. ADJUST THE CLAMPS SO THEY ARE EVENLY SPACED AND AS FAR APART AS POSSIBLE. EVERY TRUCK BED IS DIFFERENT AND YOU WILL NEED TO ADJUST THE CLAMPS SO THAT THEY ARE AT THE DEEPEST POINT IN THE BED AND THE RAILS SIT FLUSH.
- PLACE ONE RAIL CLAMP SPACER (SHOWN IN RED) ON THE END OF EACH CLAMP BOLT. TIGHTEN BOLTS SO THAT RACK IS SELF SUPPORTING.
- FULLY TIGHTEN RAIL CLAMP BOLTS TO 10N.M
- REPEAT STEPS FOR OTHER SIDE.

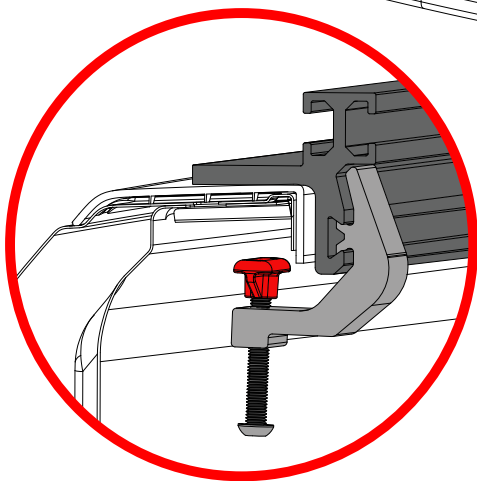
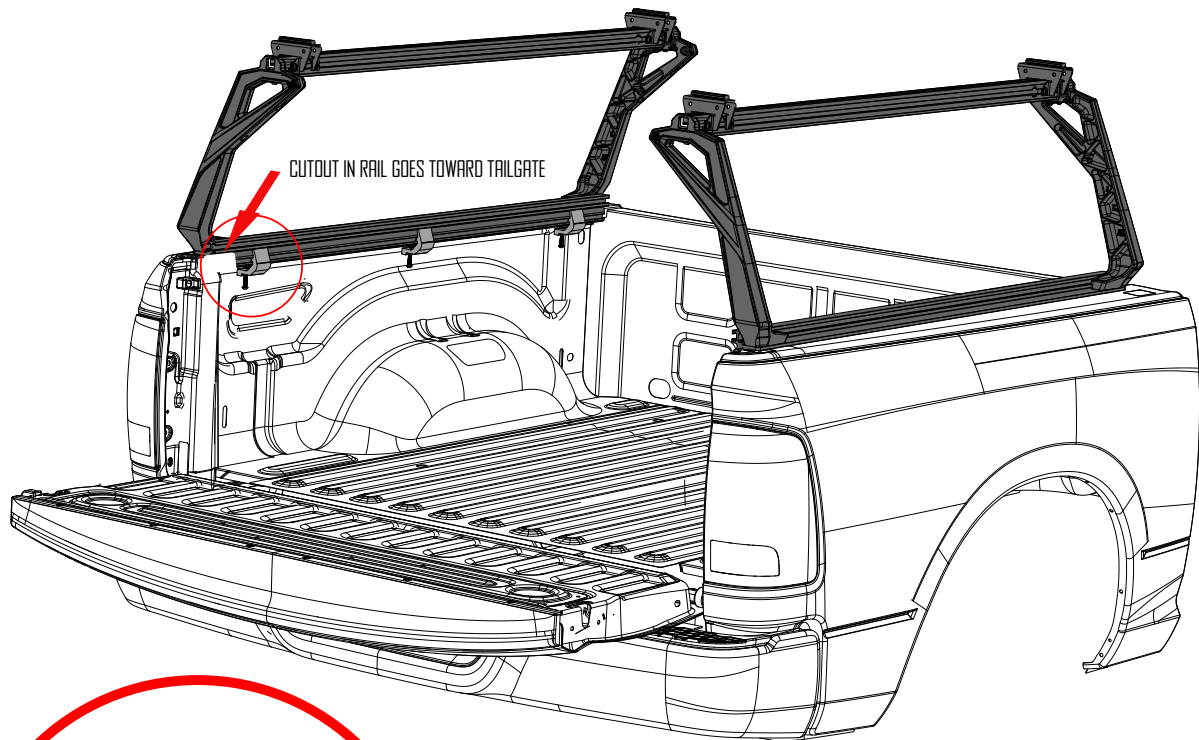

DETAIL-A

• NOTE: THE CUTOUT ON THE LOWER RAIL GOES TOWARD THE TAILGATE. ALSO THE RAILS ARE MARKED "R" FOR RIGHT AND "L" FOR LEFT JUST ABOVE THE CUTOUT INSIDE THE T-SLOT.

INSTALL: LOAD BARS

- SLIDE THE 60" LONG LOAD BARS ONTO THE T-NUTS INTO THE LOAD BAR BRACKETS AND CENTERED THEM ON THE RACK.
- TIGHTEN THE M8 X 14 BOLTS ON THE UNDERSIDE OF THE BRACKETS MAKING SURE THE LOAD BARS STAY CENTERED

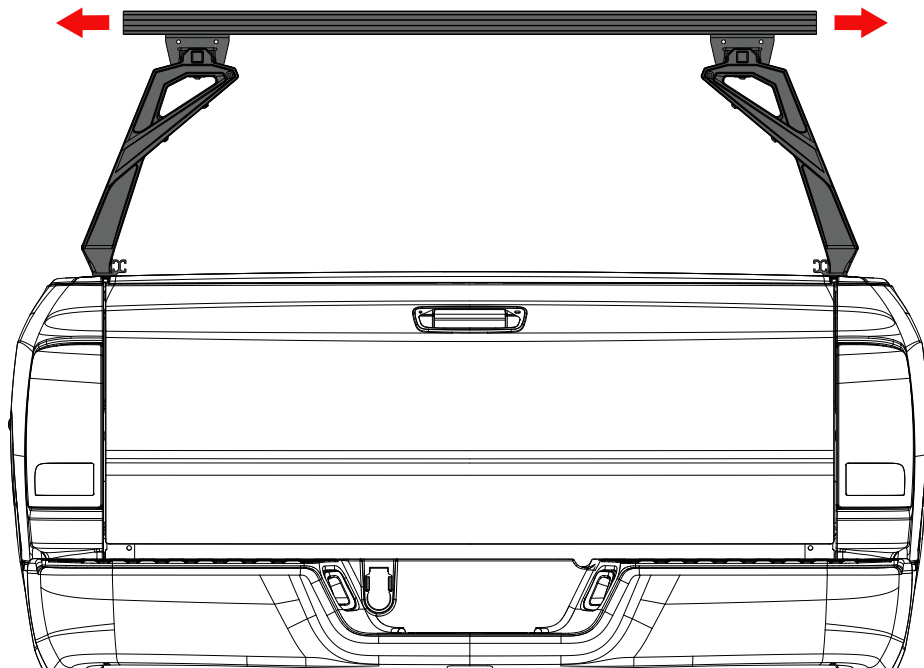
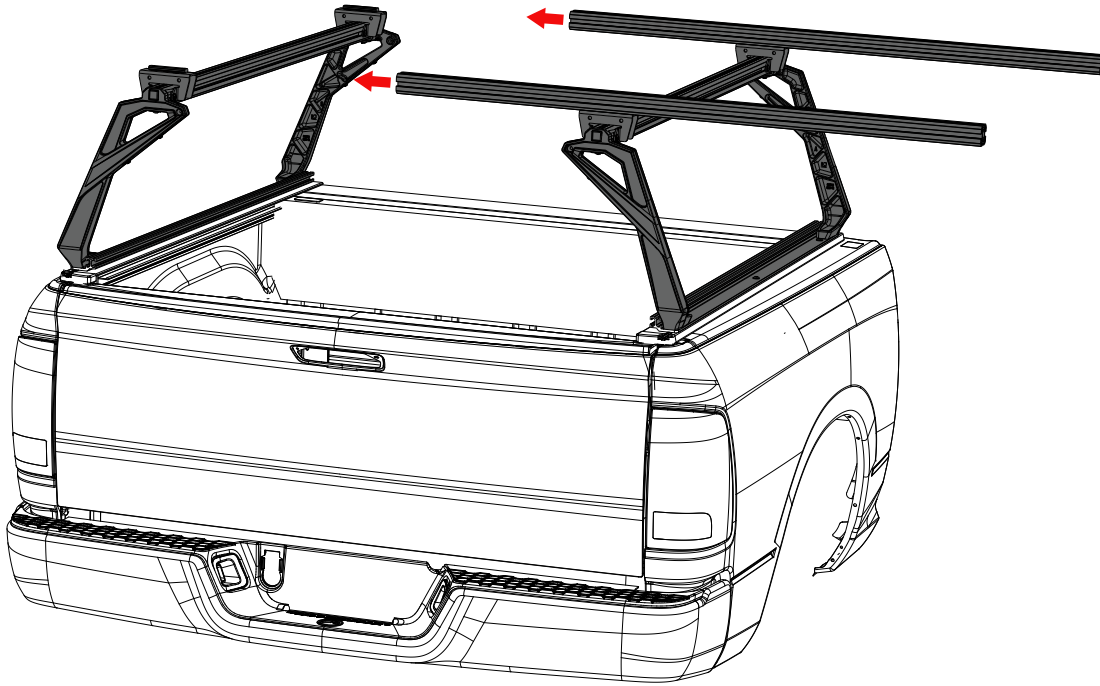

FINISH: INSTALL END CAPS AND RUBBER TREAD STRIP

• INSTALL THE RUBBER TREAD STRIP INTO THE UPPER CROSS BAR CHANNEL BY PUSHING IT INTO THE T-SLOT WITH THE PALM OF YOUR HAND. NOTE: SOME TRIMMING OF THE RUBBER TREAD STRIP MIGHT BE NECESSARY.

• INSTALL THE FOUR END CAPS INTO THE ENDS OF THE CROSS BARS.

CHECK ALL FASTENERS INSTALLED IN PREVIOUS STEPS TO ENSURE THEY ARE PROPERLY TIGHTENED

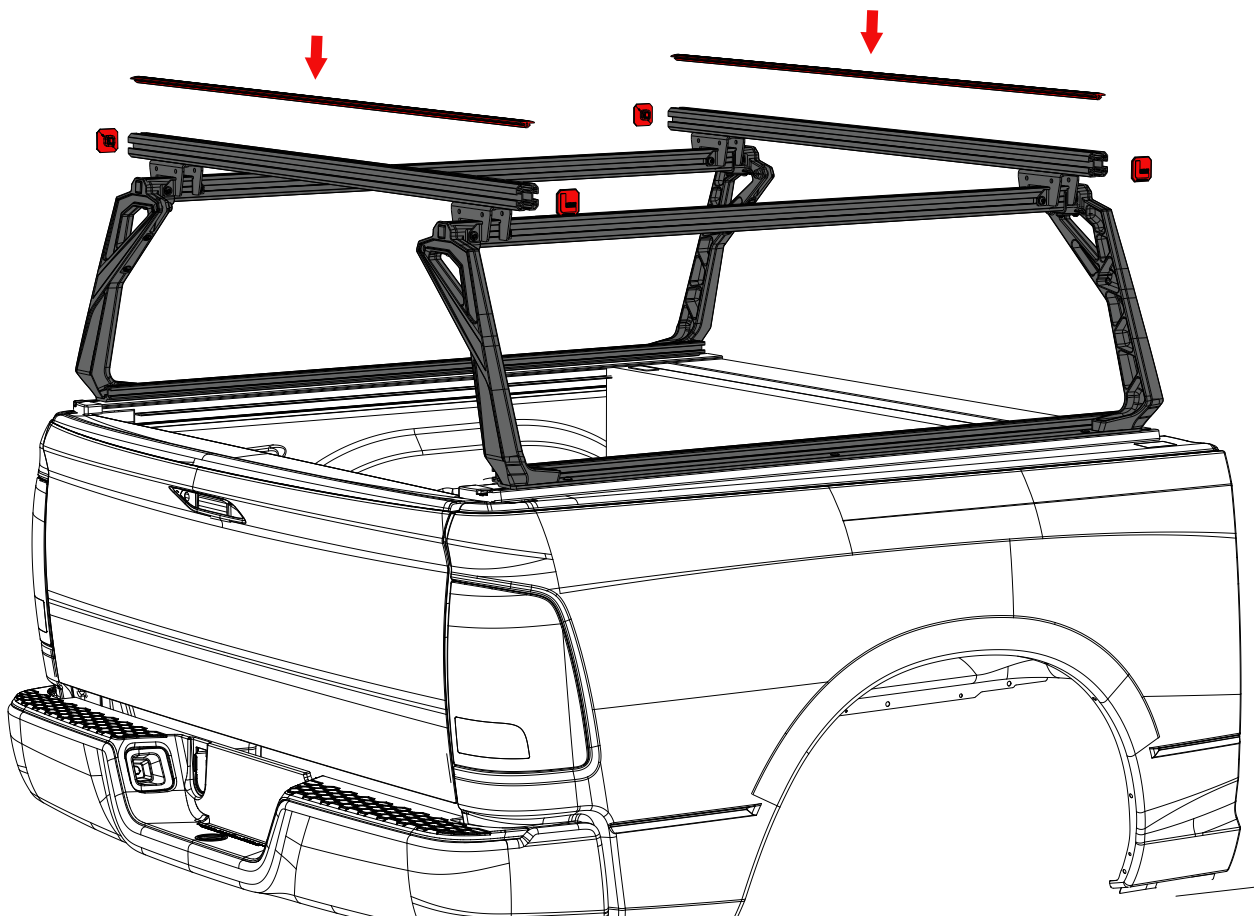

USE GUIDELINES

WHEN USING LEITNER DESIGNS CARRIERS AND ACCESSORIES, THE USER MUST UNDERSTAND THE PRECAUTIONS. THE POINTS LISTED BELOW WILL ASSIST YOU IN USING THE RACK SYSTEM AND WILL ENCOURAGE SAFETY.

-FOR QUALITY FITS AND SAFETY, USE ONLY THE RECOMMENDED RACK OR ACCESSORIES. DO NOT ASSUME A RACK WILL FIT, ALWAYS CHECK THE CURRENT FIT GUIDE WHEN OBTAINING A NEW VEHICLE.

-THE MAXIMUM LOAD IS NOT TO BE EXCEEDED. (250# OFF ROAD – 500# ON ROAD). HOWEVER, THIS LIMIT IS ALWAYS SUBORDINATE TO THE MAXIMUM LOAD RECOMMENDED BY THE MANUFACTURER OF THE VEHICLE ITSELF. IT IS ALWAYS THE LOWER MAXIMUM RECOMMENDED LOAD THAT APPLIES. $\text{MAX TRUCK LOAD} = \text{LOAD CARRIER WEIGHT} + \text{ANY FITTED CARRIER ACCESSORIES} + \text{THE WEIGHT OF THE LOAD ITSELF}$.

-HIGH SPEED OFF ROAD DRIVING EVEN WITH A LIGHT LOAD CAN CAUSE DAMAGE TO THE RACK, ACCESSORIES AND VEHICLE BODY. DAMAGE CAUSED BY HIGH SPEED DRIVING AND ABUSE IS NOT COVERED UNDER WARRANTY.

-MAKE SURE ALL KNOBS, BOLTS, SCREWS, STRAPS, AND LOCKS ARE FIRMLY ATTACHED, TIGHTENED AND LOCKED BEFORE EVERY TRIP. KNOBS, BOLTS, SCREWS, STRAPS AND LOCKS MUST BE PERIODICALLY INSPECTED FOR SIGNS OF WEAR, CORROSION, AND FATIGUE. CHECK YOUR LOAD AT STOPS DURING THE TRIP TO ENSURE CONTINUED FASTENING SECURITY.

-CHECK LOCAL AND STATE LAWS GOVERNING PROJECTION OF OBJECTS BEYOND THE PERIMETER OF A VEHICLE. BE AWARE OF THE WIDTH AND HEIGHT OF YOUR CARGO SINCE LOW CLEARANCE BRANCHES, BRIDGES, AND PARKING GARAGES CAN AFFECT THE LOAD. ALL CARGO WILL AFFECT THE VEHICLE'S DRIVING BEHAVIOR. NEVER DRIVE WITH ANY LOCK, KNOB OR RACK IN AN OPEN OR UNLOCKED POSITION. ALL LONG LOADS SUCH AS, BUT NOT LIMITED TO, SAILBOARDS, SURFBOARDS, KAYAKS, CANOES, AND LUMBER MUST BE TIED DOWN FRONT AND REAR TO THE BUMPERS OR TOW HOOKS OF THE VEHICLE.

-ALL LOCKS MUST BE TURNED AND MOVED PERIODICALLY TO ENSURE SMOOTH OPERATION. USE GRAPHITE OR DRY LUBRICANT TO HELP THIS. LEITNER DESIGNS LOCKS ARE DESIGNED TO DETER VANDALISM AND THEFT BUT SHOULD NOT BE CONSIDERED THEFT PROOF. REMOVE VALUABLE GEAR IF YOUR VEHICLE IS UNATTENDED FOR AN EXTENDED PERIOD. PLACE AT LEAST ONE KEY IN THE GLOVE COMPARTMENT.

-FOR SAFETY TO YOUR VEHICLE AND RACK SYSTEM, OBEY ALL POSTED SPEED LIMITS AND TRAFFIC CAUTIONS. ADAPT YOUR SPEED TO THE CONDITIONS OF THE ROAD AND THE LOAD BEING CARRIED.

-DO NOT USE LEITNER DESIGNS LOAD CARRIERS AND ACCESSORIES FOR PURPOSES OTHER THAN THOSE FOR WHICH THEY WERE DESIGNED. DO NOT EXCEED THEIR CARRYING CAPACITY. FAILURE TO FOLLOW THESE GUIDELINES OR THE PRODUCT'S INSTRUCTIONS WILL VOID THE WARRANTY.

WARRANTY

LEITNER DESIGNS WARRANTS PRODUCT TO BE FREE FROM DEFECTS IN MATERIAL AND WORKMANSHIP, FOR TERMS SPECIFIED BELOW, PROVIDED THERE HAS BEEN NORMAL USE AND PROPER MAINTENANCE. ALL REMEDIES UNDER THIS WARRANTY ARE LIMITED TO THE REPAIR OR REPLACEMENT OF ANY ITEM FOUND BY THE FACTORY TO BE DEFECTIVE WITHIN THE TIME PERIOD SPECIFIED. IF YOU HAVE A WARRANTY CLAIM, FIRST YOU MUST CALL OUR FACTORY AT THE NUMBER BELOW FOR INSTRUCTIONS. YOU MUST RETAIN PROOF OF PURCHASE AND SUBMIT A COPY WITH ANY ITEMS RETURNED FOR WARRANTY WORK. UPON COMPLETION OF WARRANTY WORK, IF ANY, WE WILL RETURN THE REPAIRED OR REPLACED ITEM OR ITEMS TO YOU FREIGHT PREPAID. DAMAGE TO OUR PRODUCTS CAUSED BY ACCIDENTS, FIRE, VANDALISM, NEGLIGENCE, MIS-INSTALLATION, MISUSE, ACTS OF GOD, OR BY DEFECTIVE PARTS NOT MANUFACTURED BY US, IS NOT COVERED UNDER THIS WARRANTY.

THE WARRANTY TIME PERIOD IS AS FOLLOWS: (2) TWO YEARS FROM DATE OF PURCHASE.

HIGH SPEED OFF ROAD DRIVING EVEN WITH A LIGHT LOAD CAN CAUSE DAMAGE TO THE RACK, ACCESSORIES AND VEHICLE BODY. DAMAGE CAUSED BY HIGH SPEED OFF ROAD DRIVING AND ABUSE IS NOT COVERED UNDER WARRANTY.

ANY IMPLIED WARRANTIES OF MERCHANTABILITY AND/OR FITNESS FOR A PARTICULAR PURPOSE CREATED HEREBY ARE LIMITED IN DURATION TO THE SAME DURATION AND SCOPE AS THE EXPRESS WRITTEN WARRANTY. OUR COMPANY SHALL NOT BE LIABLE FOR ANY INCIDENTAL OR CONSEQUENTIAL DAMAGE.

SOME STATES DO NOT ALLOW LIMITATIONS ON HOW LONG AN IMPLIED WARRANTY LASTS, OR THE EXCLUSION OR LIMITATION OF INCIDENTAL OR CONSEQUENTIAL DAMAGES, SO THE ABOVE LIMITATIONS OR EXCLUSIONS MAY NOT APPLY TO YOU. THIS WARRANTY GIVES YOU SPECIFIC LEGAL RIGHTS, AND YOU MAY ALSO HAVE OTHER RIGHTS THAT VARY FROM STATE TO STATE.

FOR WARRANTY ISSUES WITH THIS PRODUCT PLEASE CALL LEITNER DESIGNS CUSTOMER SERVICE **949-395-3049** OR EMAIL US AT **SUPPORT@LEITNERDESIGNS.COM**