

LEITNER

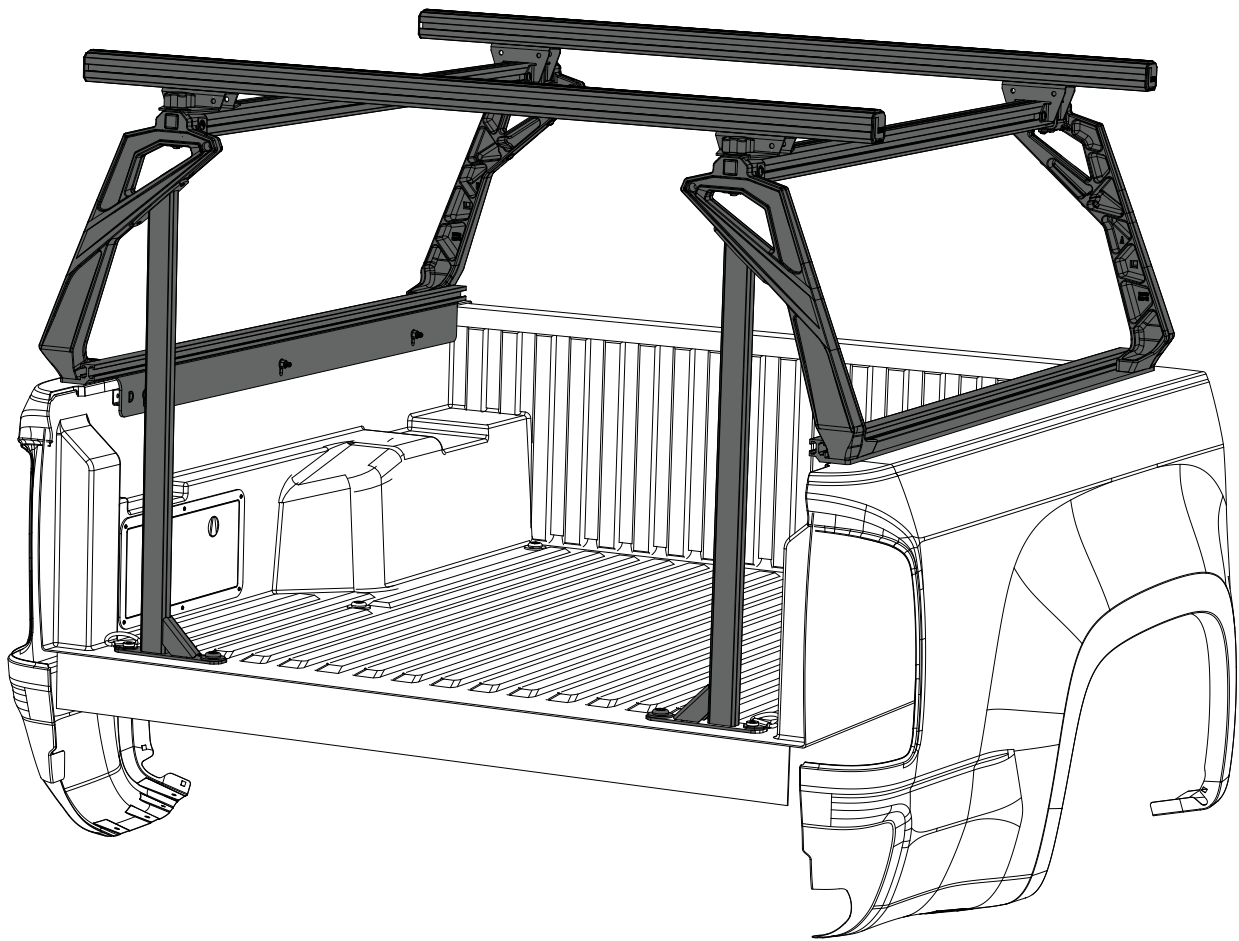

TOYOTA TACOMA

LEITNERDESIGNS.COM | SALES@LEITNERDESIGNS.COM | 949-395-3049

ASSEMBLY / INSTALLATION INSTRUCTIONS:

ACTIVE CARGO SYSTEM PART NUMBERS:

04-60-FA-1307 (2005-2015 TOYOTA TACOMA SHORT BED)

04-73-FA-1328 (2005-2015 TOYOTA TACOMA LONG BED)

04-60-FA-1311 (2016-2020 TOYOTA TACOMA SHORT BED)

04-73-FA-1329 (2016-2020 TOYOTA TACOMA LONG BED)

TOOLS REQUIRED

- TORQUE WRENCH
- T30 TORX BIT SOCKET
- T40 TORX BIT SOCKET
- 13MM WRENCH

TOOLS INCLUDED

- T30 TORX
- T40 TORX
- T55 TORX

INSTALLATION TIME

2-3 HOURS

BASIC KNOWLEDGE OF HAND TOOLS REQUIRED

SKILL LEVEL



3= INTERMEDIATE

▼ READ BEFORE INSTALLING ACTIVE CARGO SYSTEM ▼

1. THERE ARE 2 DIFFERENT UPRIGHTS CLEARLY MARKED A & B. THE A BRACKET IS USED ON THE PASSENGER SIDE BY THE CAB AND ON THE DRIVERS SIDE BY THE TAILGATE. THE B UPRIGHT IS USED BY THE DRIVERS SIDE CAB AND PASSENGERS SIDE TAILGATE. KEEP THIS IN MIND WHEN ASSEMBLING THE ACS.

2. DON'T OVER-TIGHTEN BOLTS. ALL 10MM BOLTS = (40LB-FT) ALL 8MM BOLTS = (16FT-LB) ALL 6MM BOLTS = (10FT-LB) RAIL CLAMP BOLTS (10FT-LB)
3. **NOTE: DROP IN PLASTIC BED LINERS WILL NEED TO BE REMOVED BEFORE INSTALLING ACTIVE CARGO SYSTEM.**
4. LAY DOWN A LARGE AREA OF CARPET OR BLANKETS AS A WORK AREA TO AVOID SCRATCHING PARTS DURING ASSEMBLY.
5. TWO EXTRA RIVET NUTS ARE INCLUDED IN CASE YOU MAKE A MISTAKE DURING ASSEMBLY.
6. TAKE YOUR TIME TO DO IT RIGHT. MEASURE TWICE. DRILL ONCE.
7. ALTHOUGH THE ACTIVE CARGO SYSTEM IS LIGHT HAVING A FRIEND TO HELP IS RECOMMENDED.

▼ ASSEMBLY OVERVIEW ▼

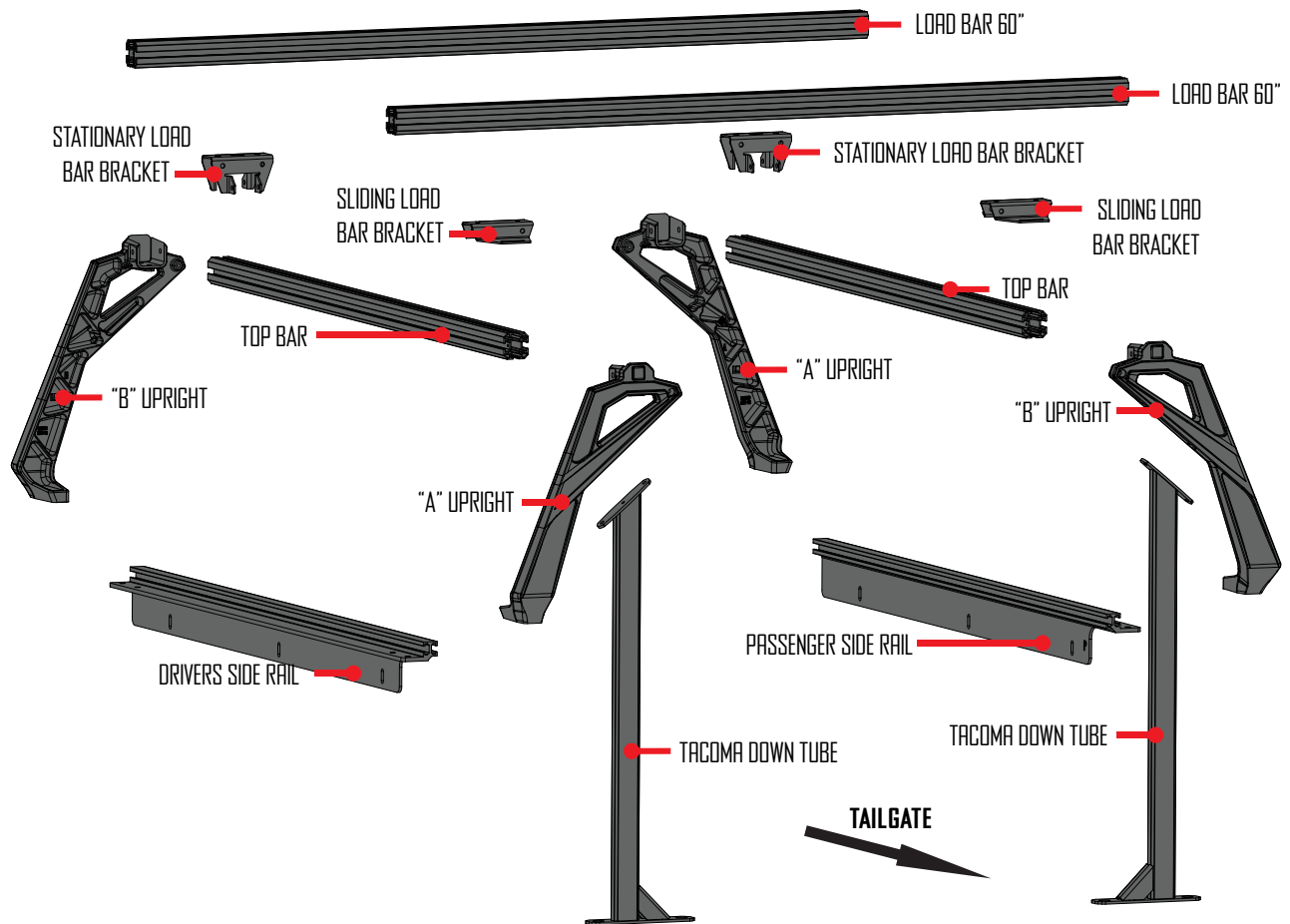

LEITNERDESIGNS.COM | SALES@LEITNERDESIGNS.COM | 949-395-3049

▼ ACTIVE CARGO SYSTEM HARDWARE ▼

LONG T-NUT
(X8)



SHORT T-NUT
(X4)



SINGLE T-NUT
(X4)

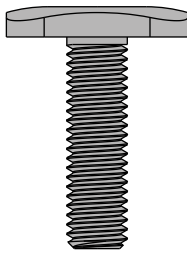
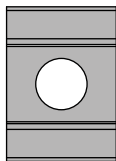

RAIL BOLT
(X6)

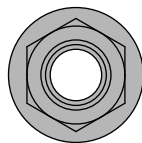

M8 NUT
(X6)

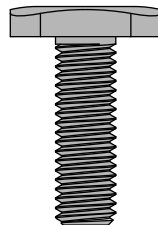

M8 T-BOLT
(X4)

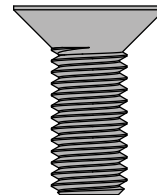

M10 X 25
(X8)

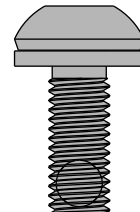

M8 X 20
(X12)

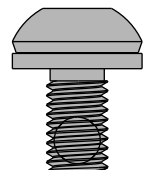

M8 X 14
(X16)

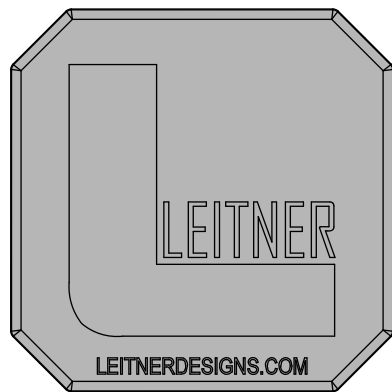

ENDCAP
(X4)

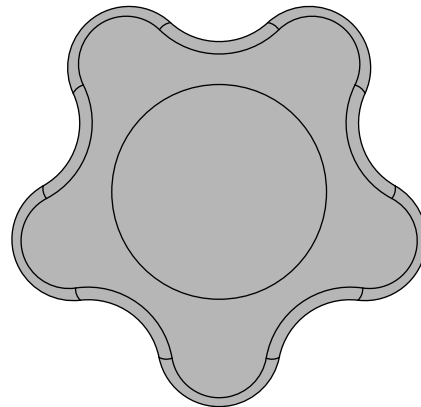

KNOB
(X4)

PREP: STATIONARY LOAD BAR BRACKET

- INSTALL 2 M8 X 14 BOLTS THROUGH BRACKET AND THREAD INTO LONG T-NUT. DO NOT TIGHTEN AT THIS TIME.
- REPEAT STEPS BELOW FOR SECOND BRACKET.
- SET ASIDE FOR USE IN A LATER STEP.

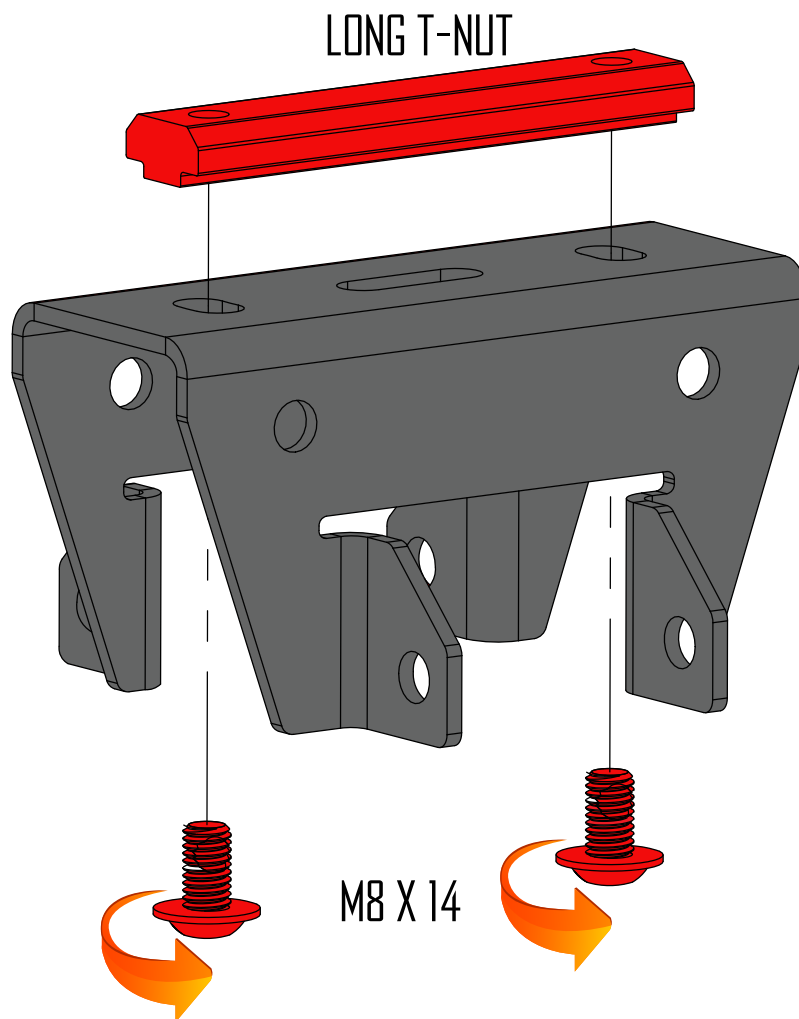

PREP: SLIDING LOAD BAR BRACKETS

- INSTALL 2 M8 X 14 BOLTS THROUGH BRACKET AND THREAD INTO LONG T-NUT. DO NOT TIGHTEN AT THIS TIME.
- REPEAT STEPS BELOW FOR SECOND BRACKET.
- SET ASIDE FOR USE IN A LATER STEP.

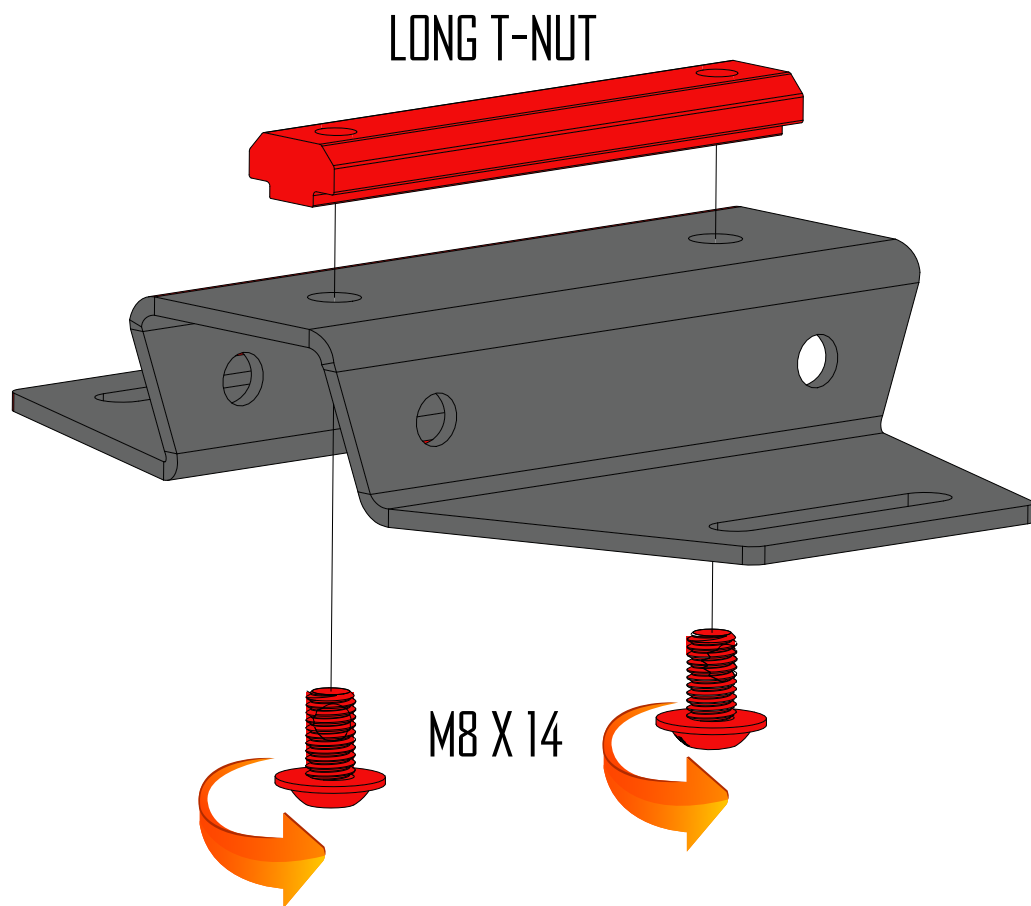

ASSEMBLE DRIVER SIDE: OVERVIEW

- IN THE NEXT FEW STEPS YOU WILL ASSEMBLE THE DRIVERS SIDE PORTION OF THE ACTIVE CARGO SYSTEM.
- THE ILLUSTRATION BELLOW SHOWS WHAT THE PART WILL LOOK LIKE WHEN FULLY ASSEMBLED. YOU CAN REFER BACK TO THIS ILLUSTRATION AT ANY TIME TO CLARIFY PART LOCATION.

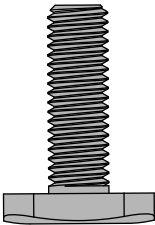
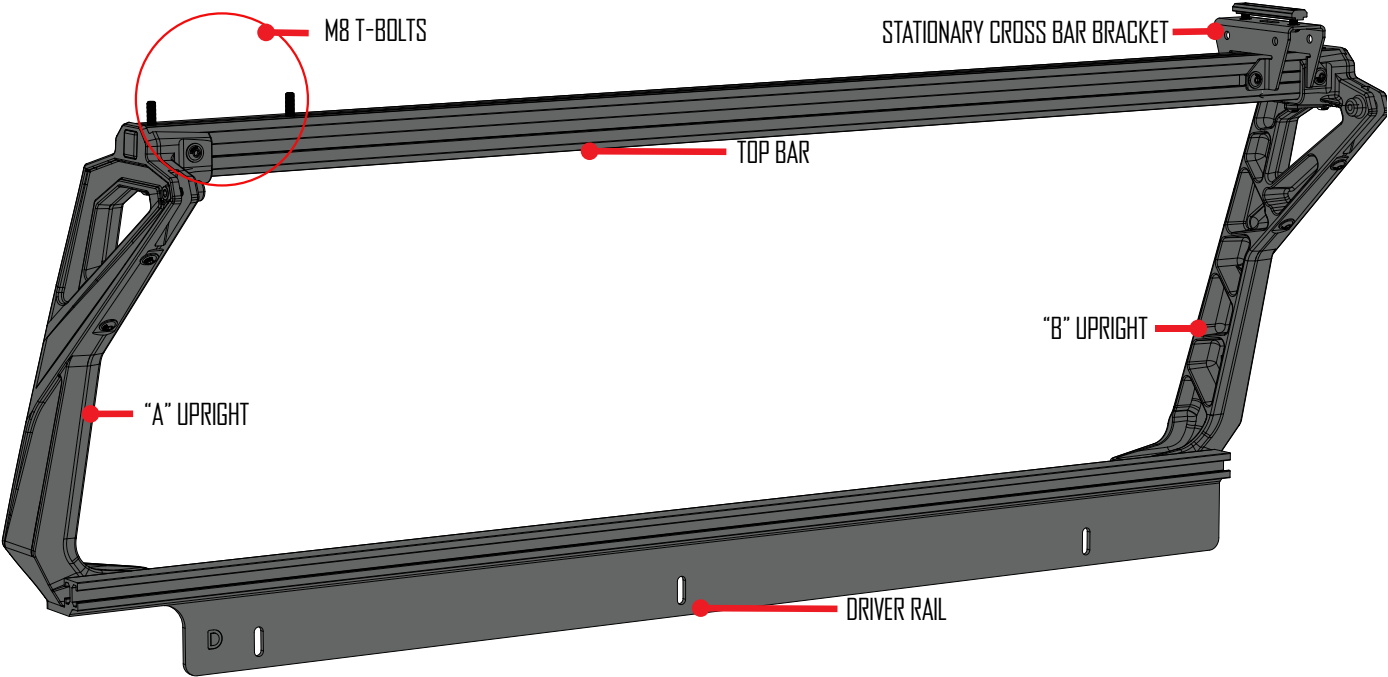

M8 T-BOLT

TWO (2) M8 T-BOLTS NEED TO BE SLIDE INTO THE UPPER MOST T-TRACK BEFORE ASSEMBLING THE UPRIGHTS. IF YOU FORGET THIS STEP YOU WILL NOT BE ABLE TO INSTALL THE SLIDING LOAD BAR BRACKETS ON PAGE 22!! WE WILL REMIND YOU TO DO THIS AGAIN SO DONT MESS THIS UP!!

ASSEMBLE DRIVER SIDE: UPRIGHT "A"

- ASSEMBLE UPRIGHT MARKED "A" AS SHOWN IN THE FOLLOWING DIAGRAM.
- THREAD TWO M8 X 20 BOLTS INTO THE SHORT T-NUT. DO NOT TIGHTEN AT THIS TIME.
- THREAD ONE M8 X 14 BOLTS INTO EACH ONE OF THE SINGLE T-NUTS. DO NOT TIGHTEN AT THIS TIME.
- SET ASIDE FOR USE IN A LATER STEP.

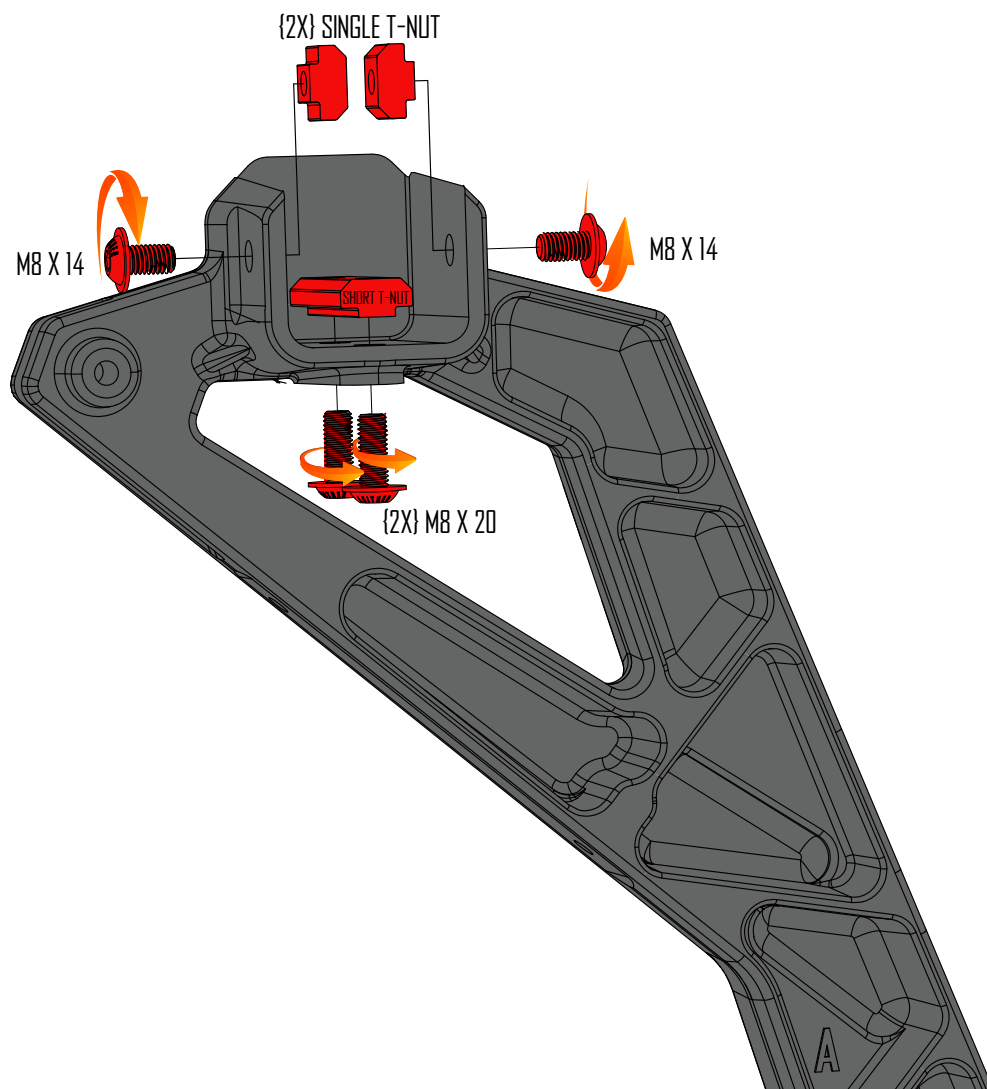

ASSEMBLE DRIVER SIDE: UPRIGHT "B"

- ASSEMBLE UPRIGHT MARKED "B" AS SHOWN IN THE FOLLOWING DIAGRAM.
- THREAD TWO M8 X 20 BOLTS INTO THE SHORT T-NUT. {FIG-A} DO NOT TIGHTEN AT THIS TIME.
- THREAD TWO M8X 20 BOLTS THROUGH CROSS BAR BRACKET AND UPRIGHT INTO LONG T-NUT {FIG-B} DO NOT TIGHTEN AT THIS TIME.
- THREAD TWO M8X 14 BOLTS THROUGH CROSS BAR BRACKET INTO LONG T-NUT {FIG-B} DO NOT TIGHTEN AT THIS TIME.

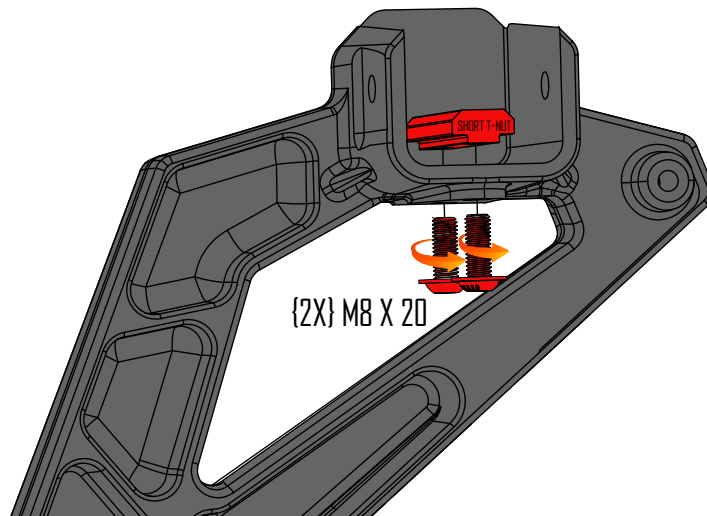

FIG-A

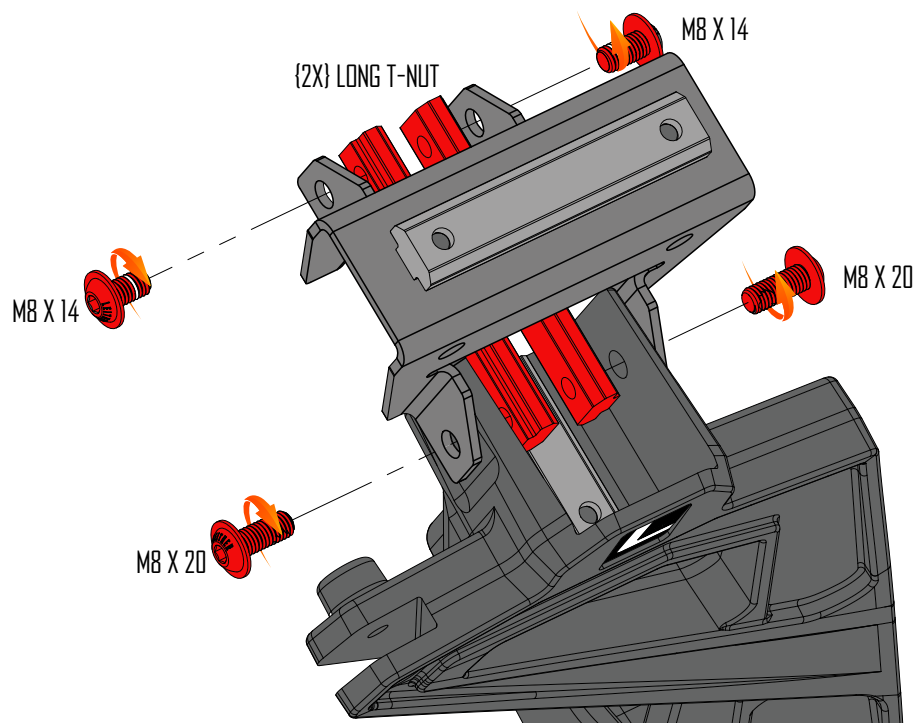
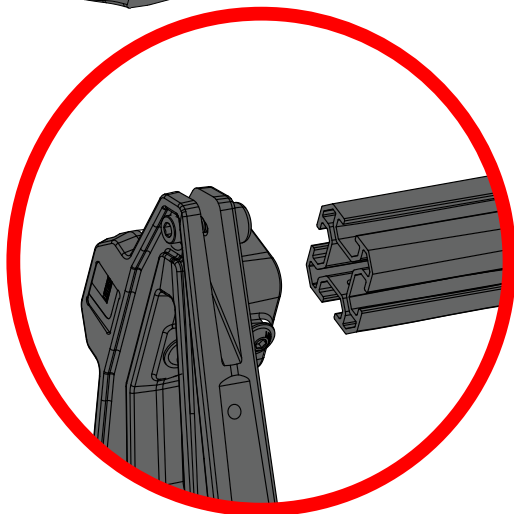

FIG-B

ASSEMBLE DRIVER SIDE: TOP BAR

• ATTACH A & B UPRIGHT ASSEMBLES TO TOP BAR AS SHOWN IN ILLUSTRATION BELOW. DO NOT TIGHTEN BOLTS AT THIS TIME.

• **NOTE: MAKE SURE YOU SLIDE THE TWO (2) T-BOLTS INTO THE UPPER MOST T-TRACK**



DETAIL-1

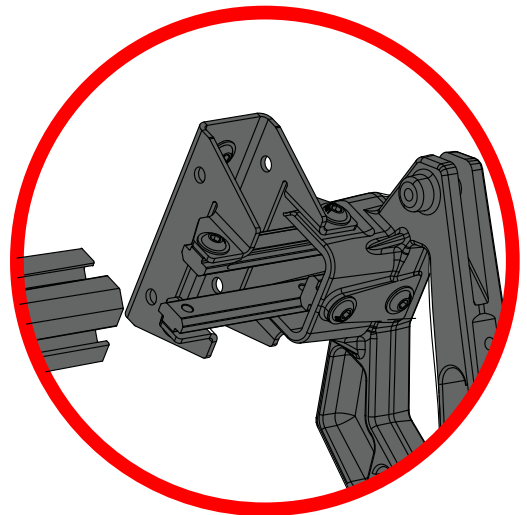

DETAIL-2



TWO (2) M8 T-BOLTS NEED TO BE SLIDE INTO THE UPPER MOST T-TRACK BEFORE ASSEMBLING THE UPRIGHTS. IF YOU FORGET THIS STEP YOU WILL NOT BE ABLE TO INSTALL THE SLIDING LOAD BAR BRACKETS!

ASSEMBLE DRIVER SIDE: RAIL

- ATTACH RAIL TO UPRIGHTS USING FOUR M10 X 25 SCREWS. TORQUE TO 40 FT-LB USING A T40 TORX WRENCH.
- TORQUE ALL M8 BOLTS INSTALLED IN PREVIOUS STEP TO 18 FT-LB USING A T40 TORX WRENCH.
- **IMPORTANT: TIGHTEN M10X22 BOLTS FIRST THEN TORQUE THE M8 BOLTS.**

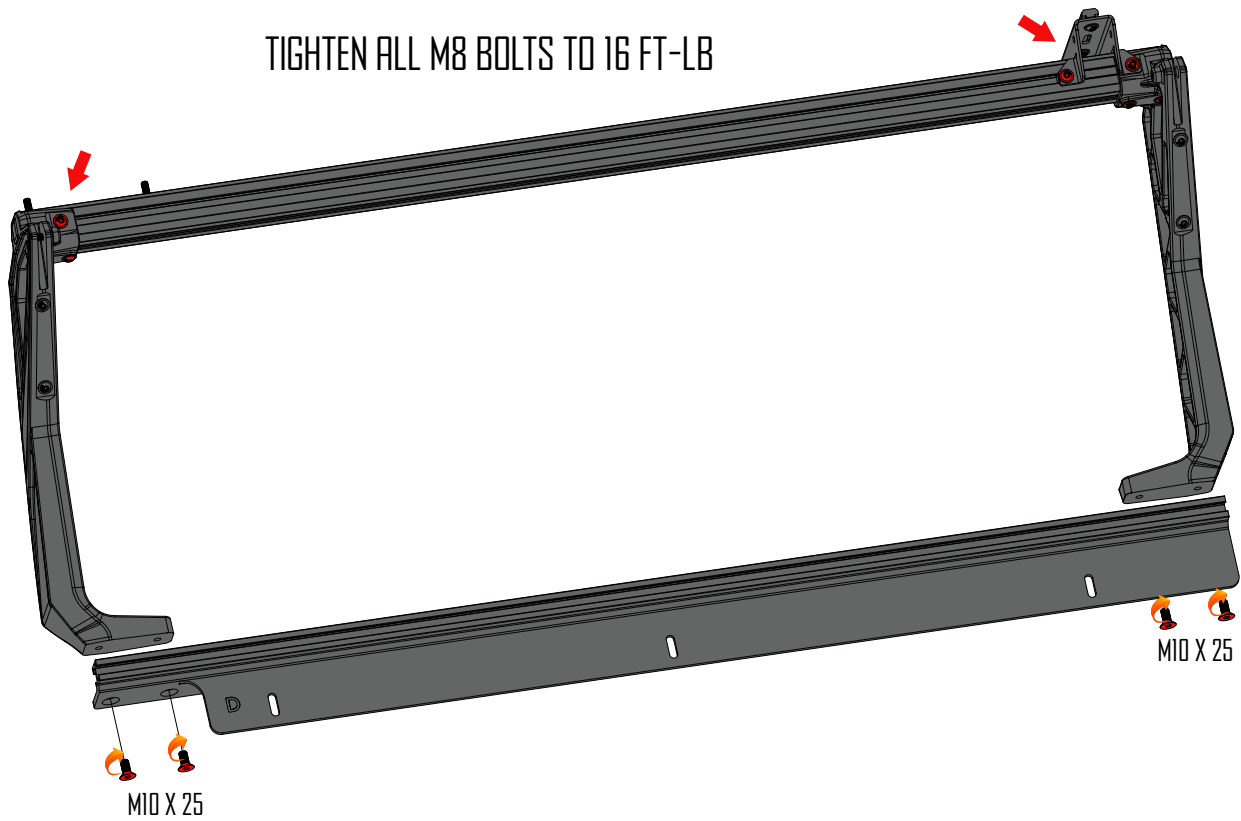

ASSEMBLE PASSENGER SIDE: OVERVIEW

- IN THE NEXT FEW STEPS YOU WILL ASSEMBLE THE PASSENGER SIDE PORTION OF THE ACTIVE CARGO SYSTEM.
- THE ILLUSTRATION BELLOW SHOWS WHAT THE PART WILL LOOK LIKE WHEN FULLY ASSEMBLED. YOU CAN REFER BACK TO THIS ILLUSTRATION AT ANY TIME TO CLARIFY PART LOCATION.

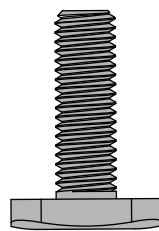
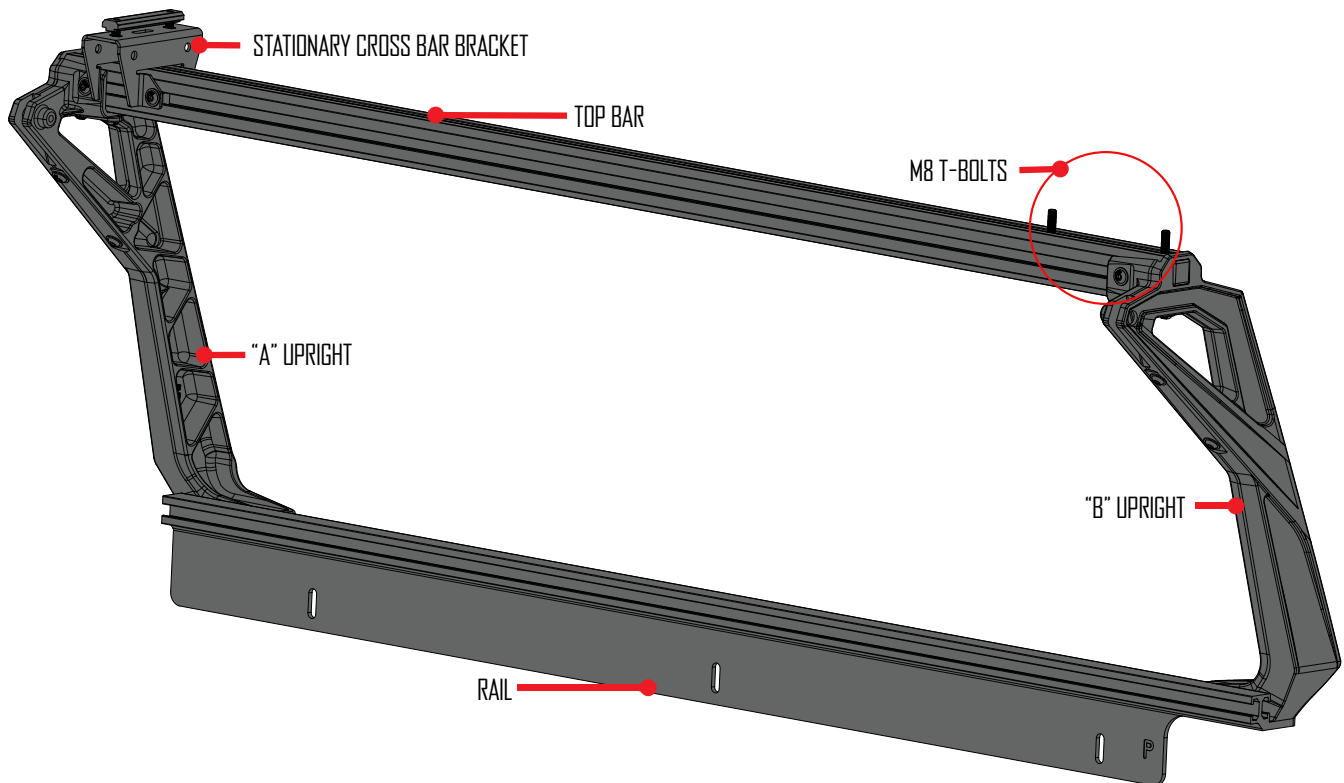

M8 T-BOLT

THE TWO (2) M8 T-BOLTS NEED TO BE SLIDE INTO THE UPPER MOST T-TRACK BEFORE ASSEMBLING THE UPRIGHTS. IF YOU FORGET THIS STEP YOU WILL NOT BE ABLE TO INSTALL THE SLIDING LOAD BAR BRACKETS ON PAGE 22!! WE WILL REMIND YOU TO DO THIS AGAIN SO DONT MESS THIS UP.

ASSEMBLE PASSENGER SIDE: UPRIGHT "B"

- ASSEMBLE UPRIGHT MARKED "B" AS SHOWN IN THE FOLLOWING DIAGRAM.
- THREAD TWO M8 X 20 BOLTS INTO THE SHORT T-NUT. DO NOT TIGHTEN AT THIS TIME.
- THREAD ONE M8 X 14 BOLTS INTO EACH ONE OF THE SINGLE T-NUTS. DO NOT TIGHTEN AT THIS TIME.
- SET ASIDE FOR USE IN A LATER STEP.

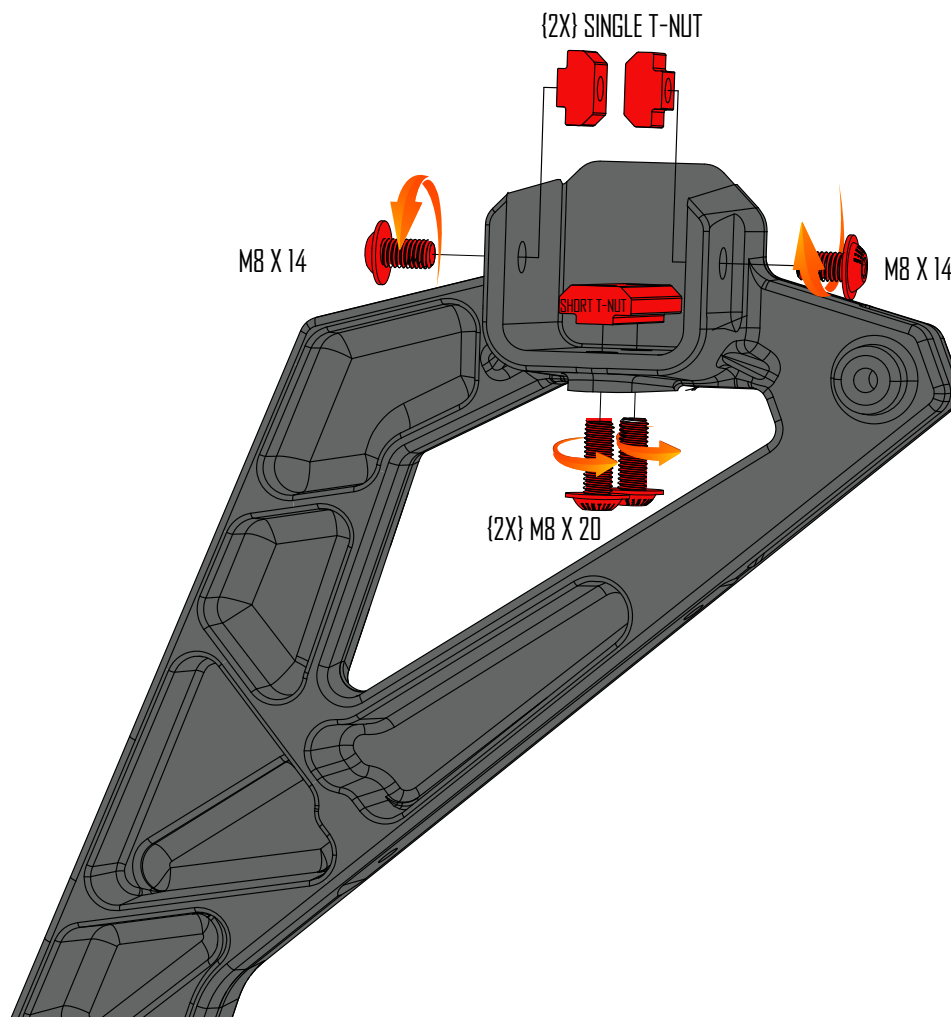

ASSEMBLE PASSENGER SIDE: UPRIGHT "A"

- ASSEMBLE UPRIGHT MARKED "A" AS SHOWN IN THE FOLLOWING DIAGRAM.
- THREAD TWO M8 X 20 BOLTS INTO THE SHORT T-NUT. {FIG-A} DO NOT TIGHTEN AT THIS TIME.
- THREAD TWO M8X 20 BOLTS THROUGH CROSS BAR BRACKET AND UPRIGHT INTO LONG T-NUT {FIG-B} DO NOT TIGHTEN AT THIS TIME.
- THREAD TWO M8X 14 BOLTS THROUGH CROSS BAR BRACKET INTO LONG T-NUT {FIG-B} DO NOT TIGHTEN AT THIS TIME.

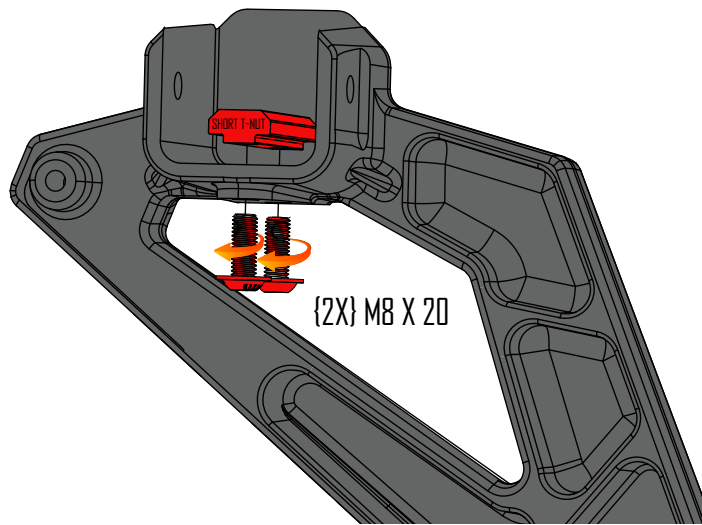

FIG-A

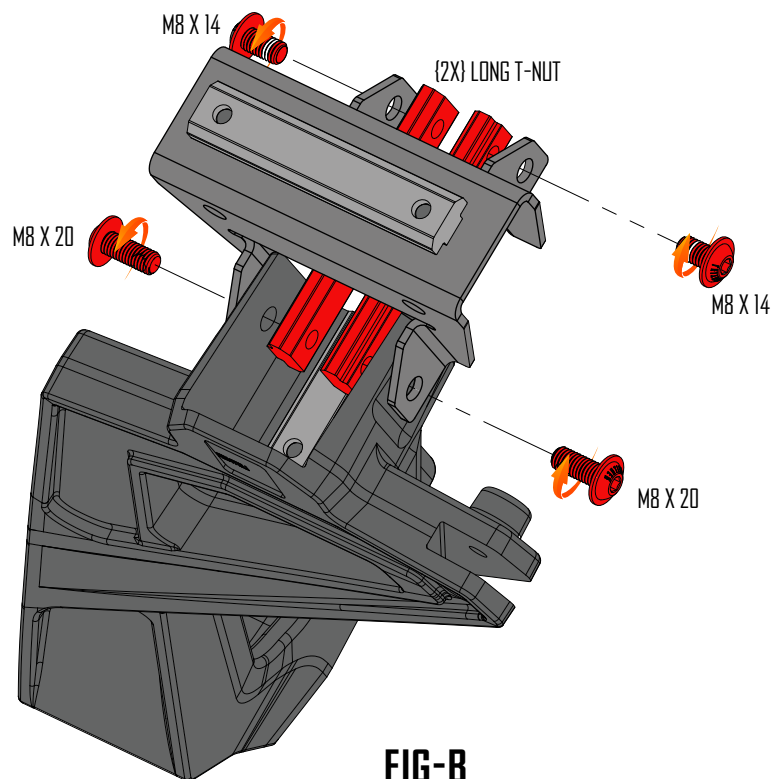
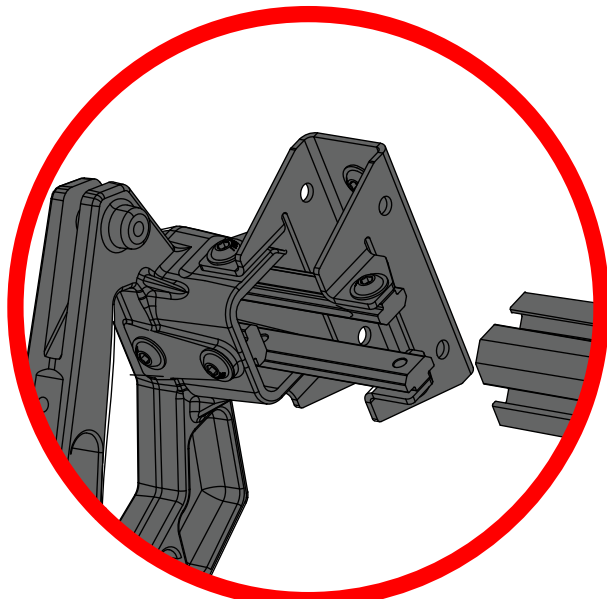
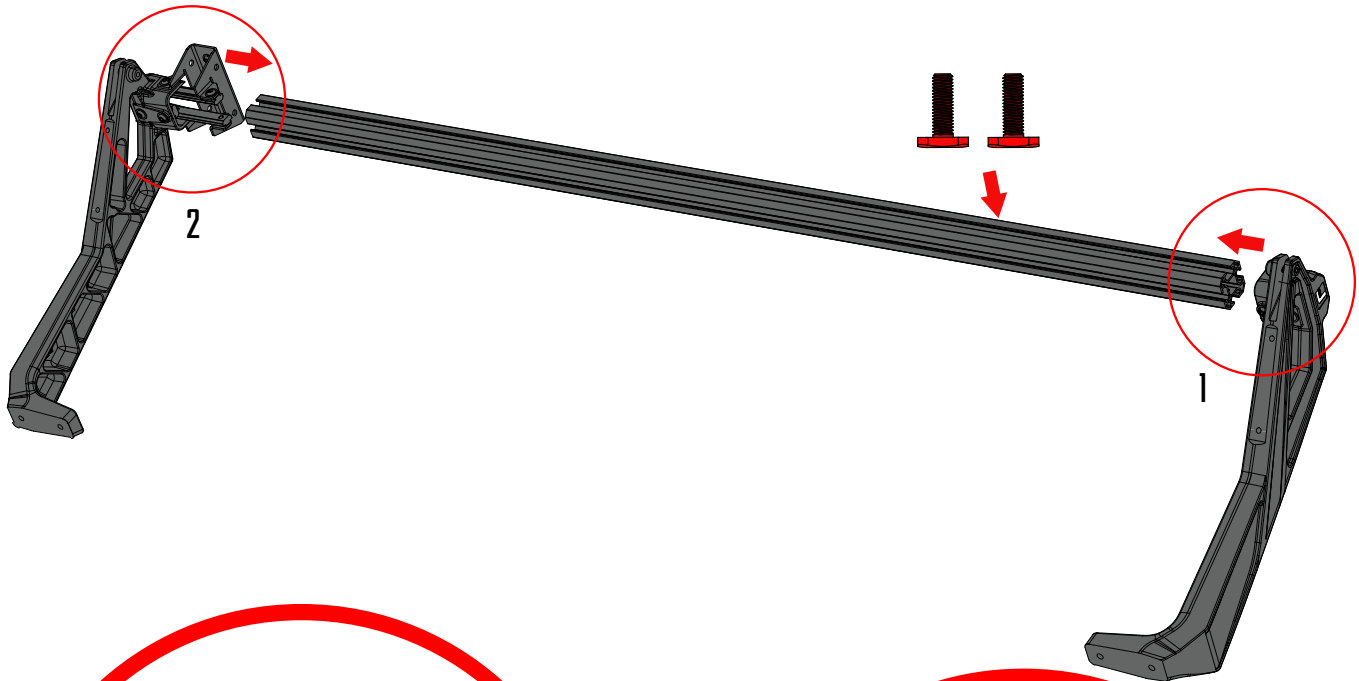

FIG-B

ASSEMBLE PASSENGER SIDE: TOP BAR

• ATTACH A & B UPRIGHT ASSEMBLES TO TOP BAR AS SHOWN IN ILLUSTRATION BELOW. DO NOT TIGHTEN BOLTS AT THIS TIME.

• **NOTE: MAKE SURE YOU SLIDE THE TWO (2) T-BOLTS INTO THE UPPER MOST T-TRACK**



DETAIL-2

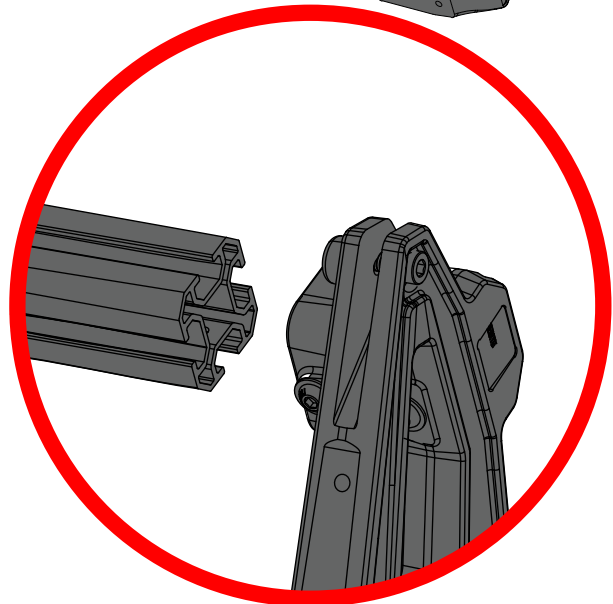

DETAIL-1



TWO (2) M8 T-BOLTS NEED TO BE SLID INTO THE UPPER MOST T-TRACK BEFORE ASSEMBLING THE UPRIGHTS. IF YOU FORGET THIS STEP YOU WILL NOT BE ABLE TO INSTALL THE SLIDING LOAD BAR BRACKETS!

ASSEMBLE PASSENGER SIDE: RAIL

- ATTACH RAIL TO UPRIGHTS USING FOUR M10 X 25 SCREWS. TORQUE TO 40 FT-LB USING A T40 TORX WRENCH.
- TORQUE ALL M8 BOLTS INSTALLED IN PREVIOUS STEP TO 16 FT-LB USING A T40 TORX WRENCH.
- **IMPORTANT: TIGHTEN M10X22 BOLTS FIRST THEN TORQUE THE M8 BOLTS.**

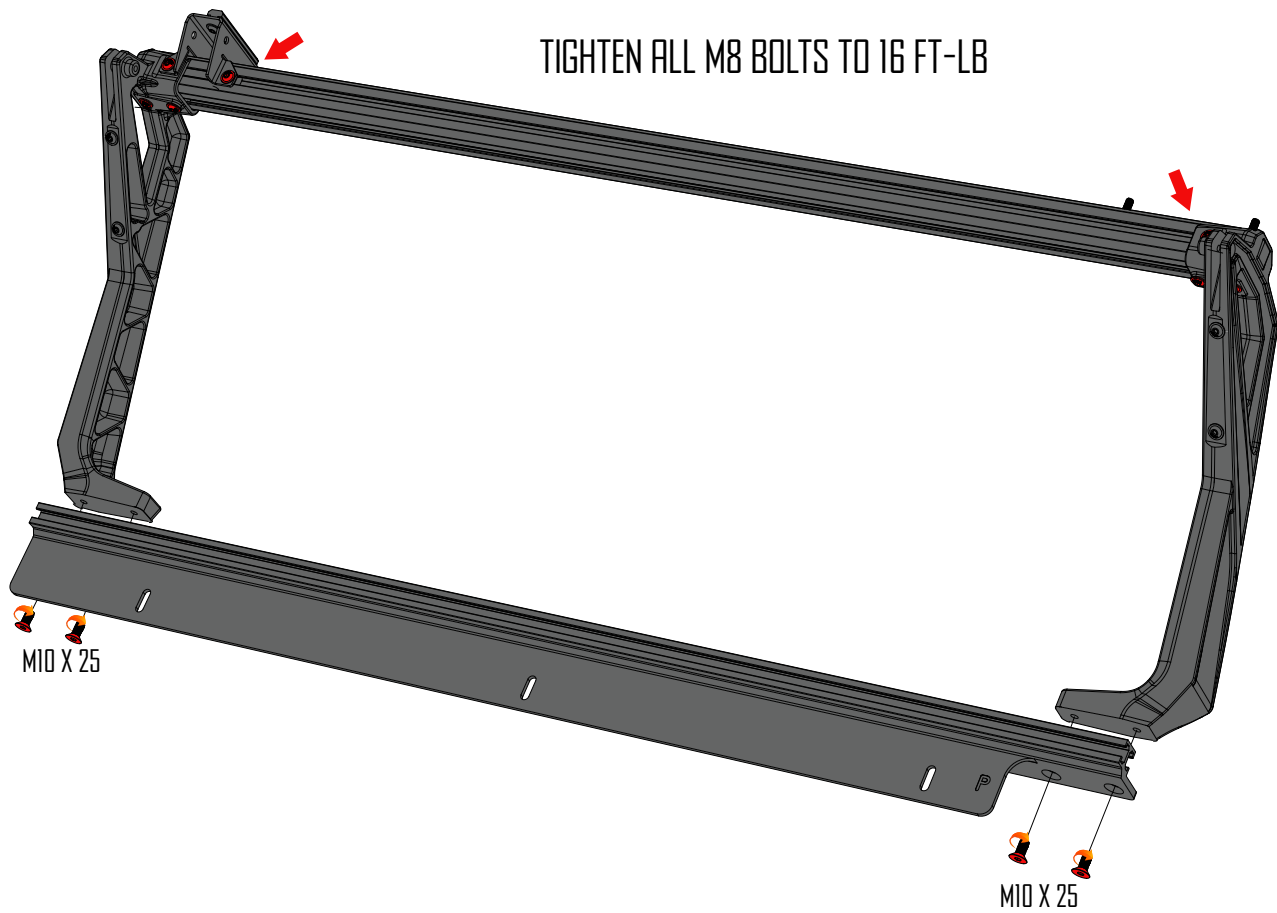

ASSEMBLE: TACOMA DOWN TUBES

• REMOVE TWO M8X14 SCREWS FROM THE UPRIGHT. USING THESE SCREWS ATTACH THE TACOMA DOWN TUBES AS SHOWN.

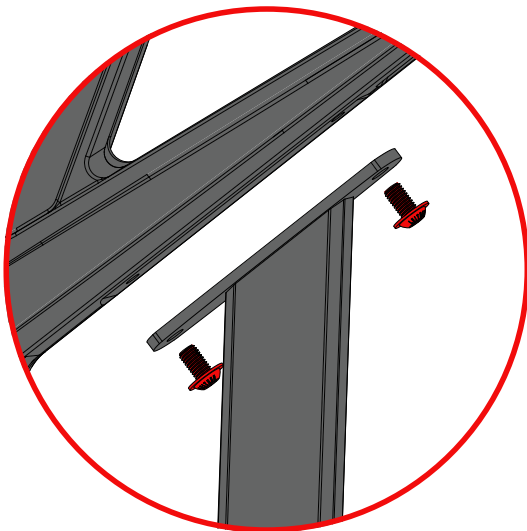
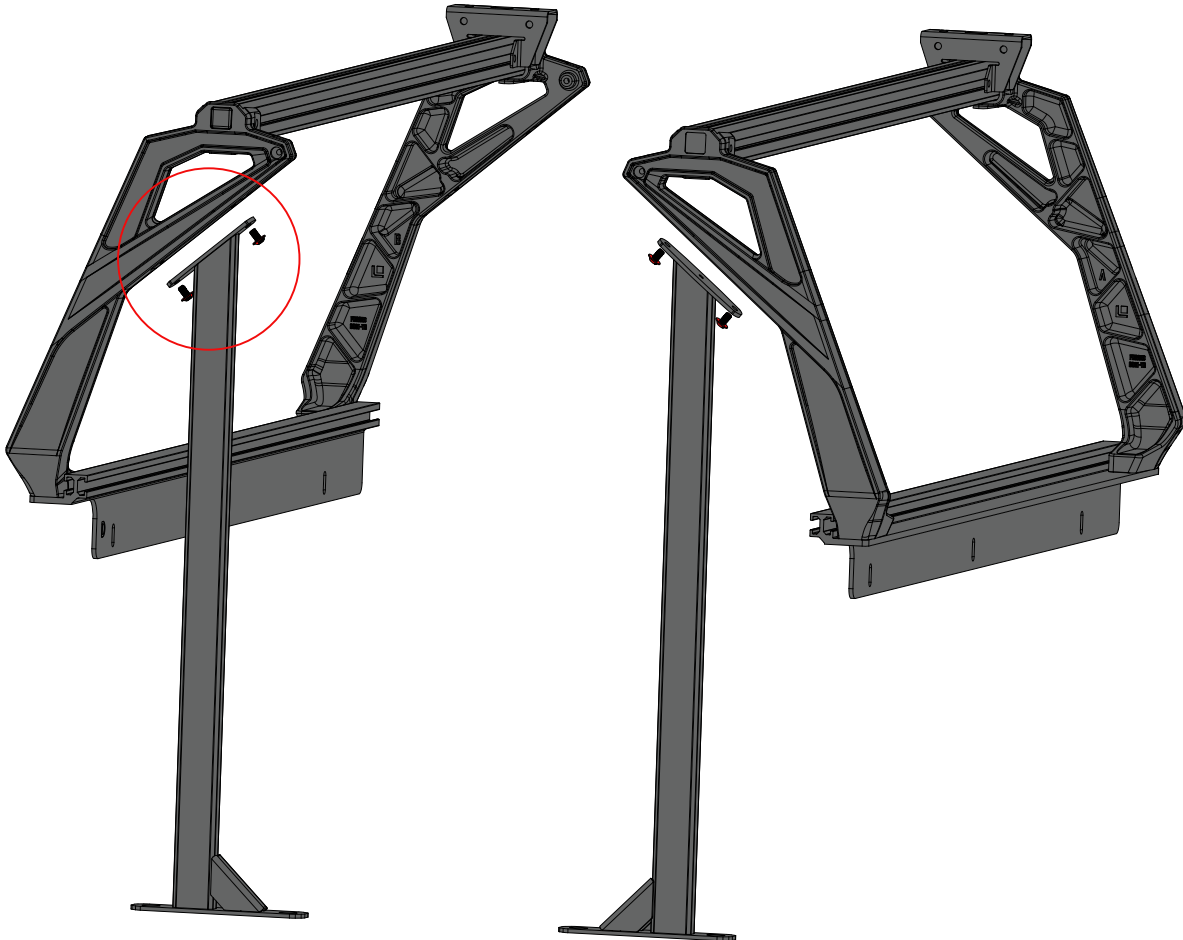

PREP: TACOMA BED

- INSTALL THREE RAIL BOLTS INTO BOTH THE PASSENGER AND DRIVERS SIDE TRAIL RAILS.
- NOTE: YOU WILL NEED TO REMOVE THE FACTORY TIE DOWNS FIRST.

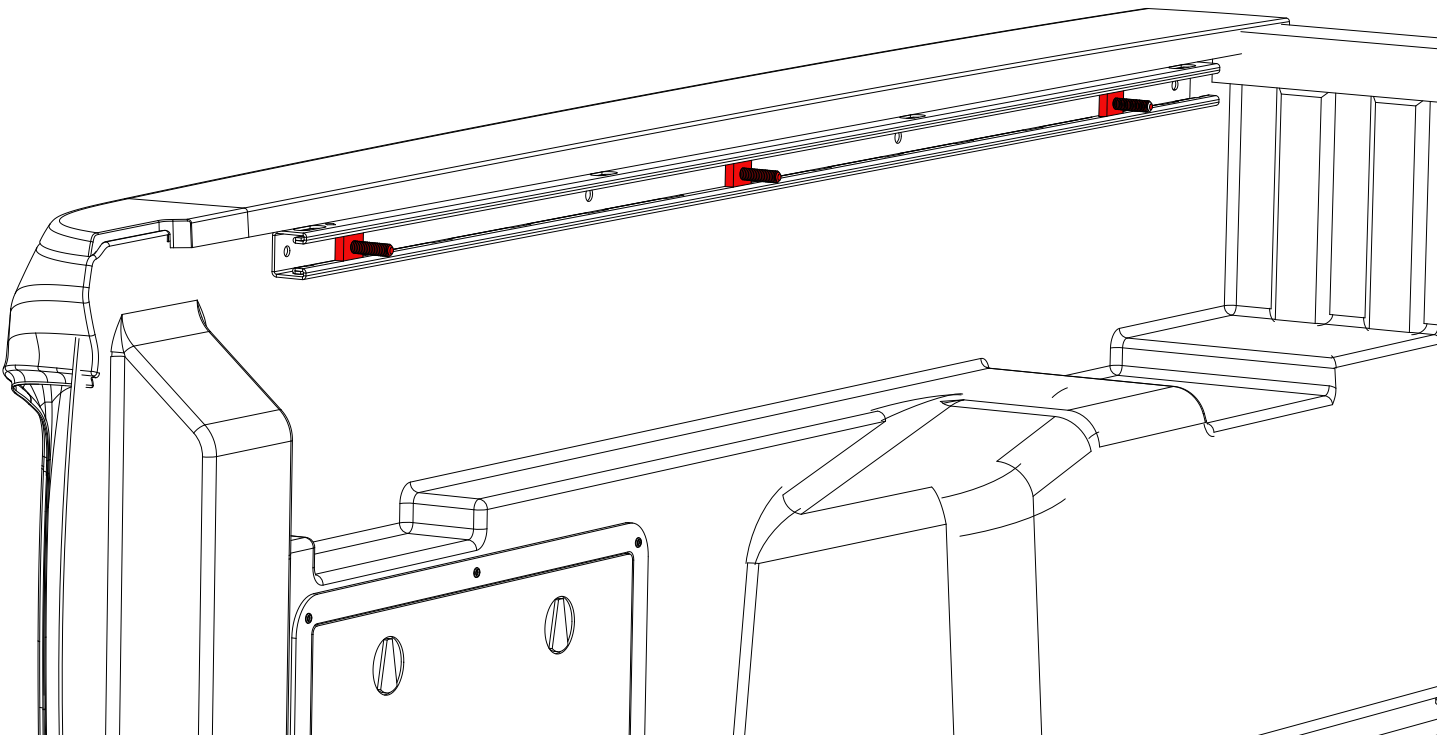

PREP: TACOMA BED

- REMOVE THE 2 REAR BED BOLTS USING A T55 TORX WRENCH. SET ASIDE FOR USE LATER.
- REMOVE THE TWO REAR TIE DOWN RINGS USING A T40 TORX WRENCH. SET ASIDE FOR USE LATER

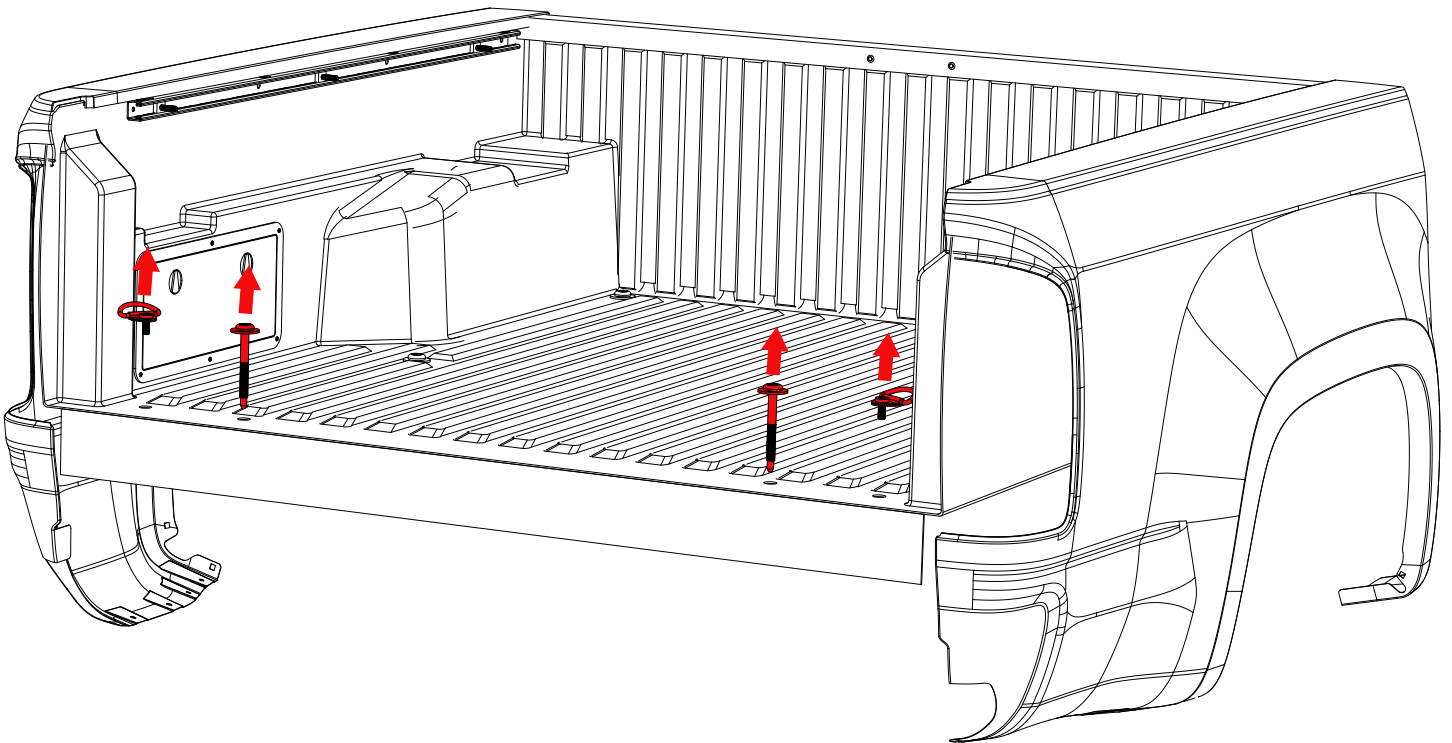

INSTALL: RACK TO TRUCK

- PLACE THE DRIVERS SIDE ASSEMBLY ONTO THE BED RAIL OF THE TRUCK. THE "D" WILL BE TOWARD THE TAILGATE.
- ALIGN THE HOLES IN THE UPRIGHT SUPPORTS WITH THE HOLES IN THE FLOOR OF THE TRUCKED, REPLACE BOLTS. [DETAIL - A]
- USING THREE M8 NUT ATTACH THE ASSEMBLY TO THE TRUCK. [DETAIL - B]
- REPEAT STEPS FOR PASSENGER SIDE.

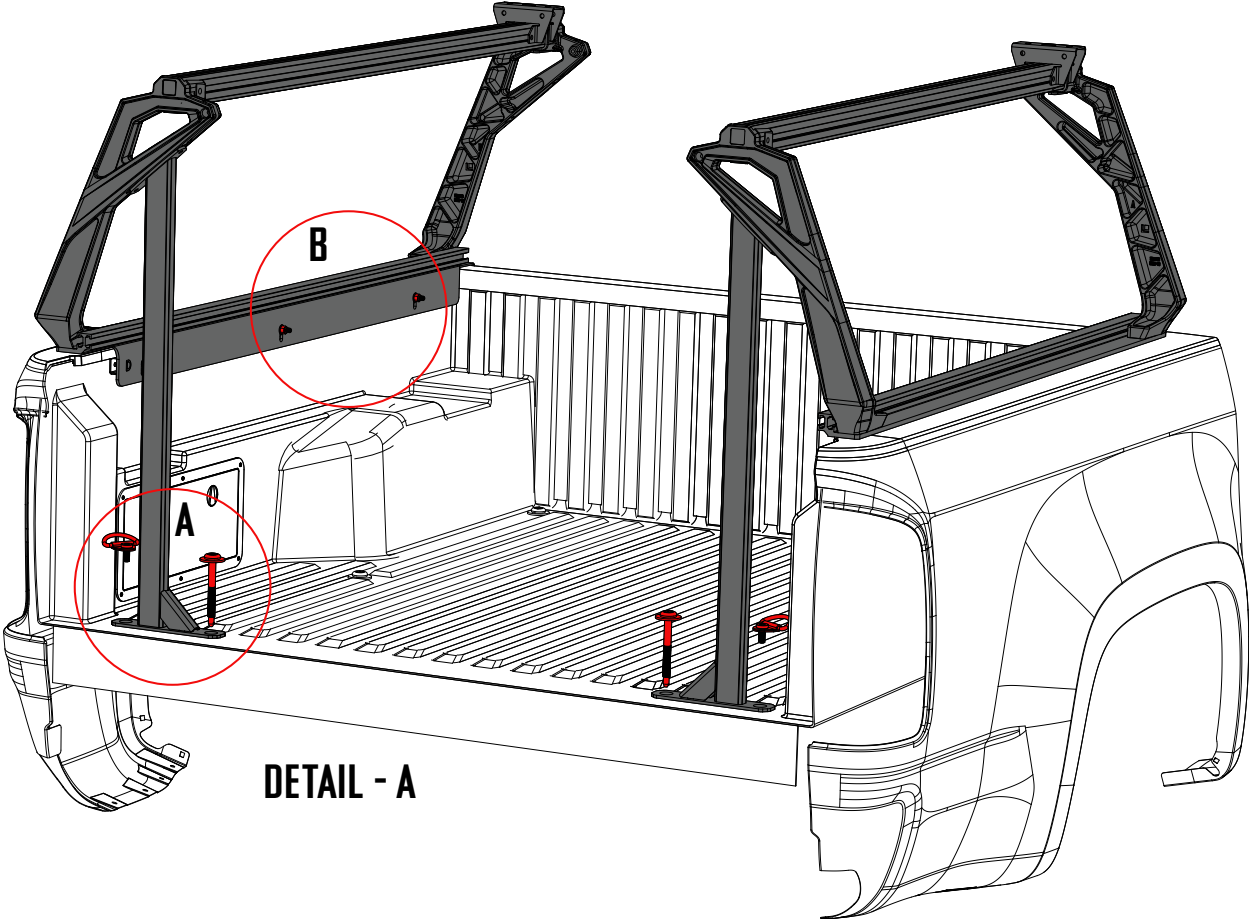

DETAIL - A

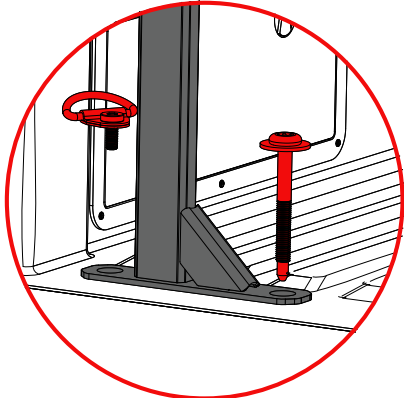

DETAIL - A

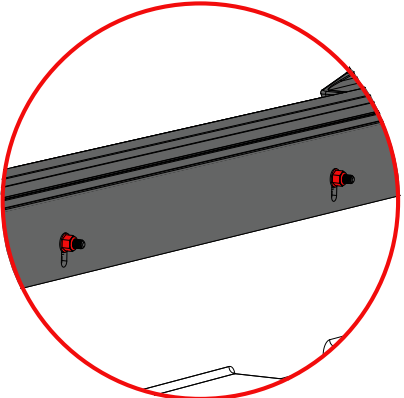

DETAIL - B

ASSEMBLE: FRONT LOAD BAR TO BRACKETS

- SLIDE THE 60" LONG LOAD BARS ONTO THE T-NUTS IN THE STATIONARY LOAD BAR BRACKETS AND CENTER THEM ON THE RACK.
- TIGHTEN THE FOUR M8 SCREWS ON THE UNDERSIDE OF THE BRACKET USING A T40 TORX WRENCH.

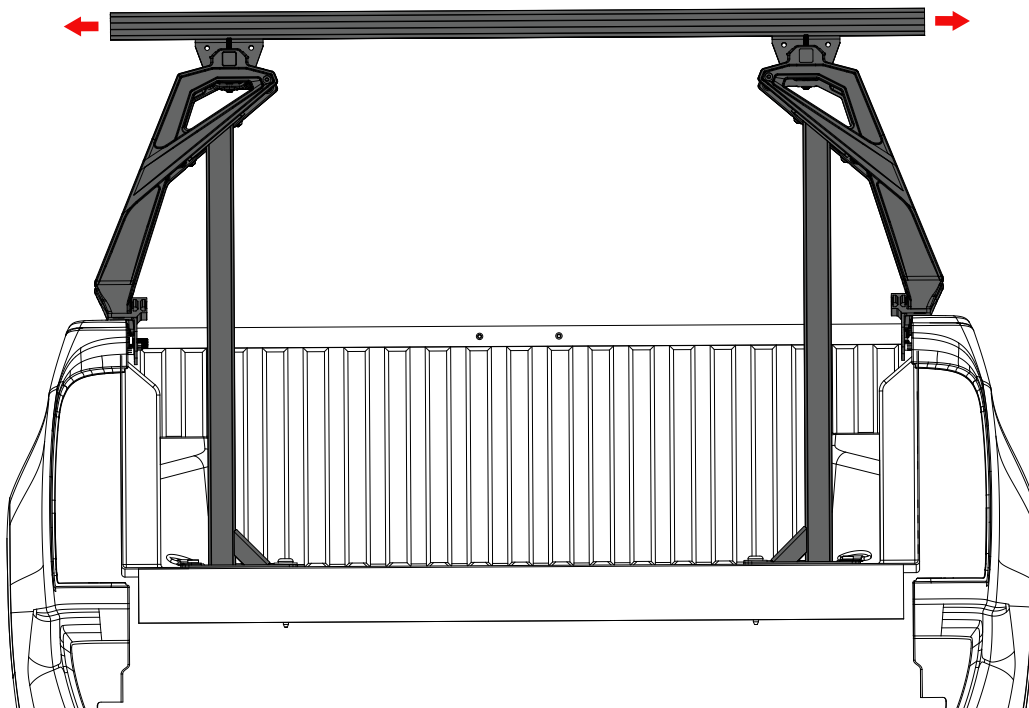
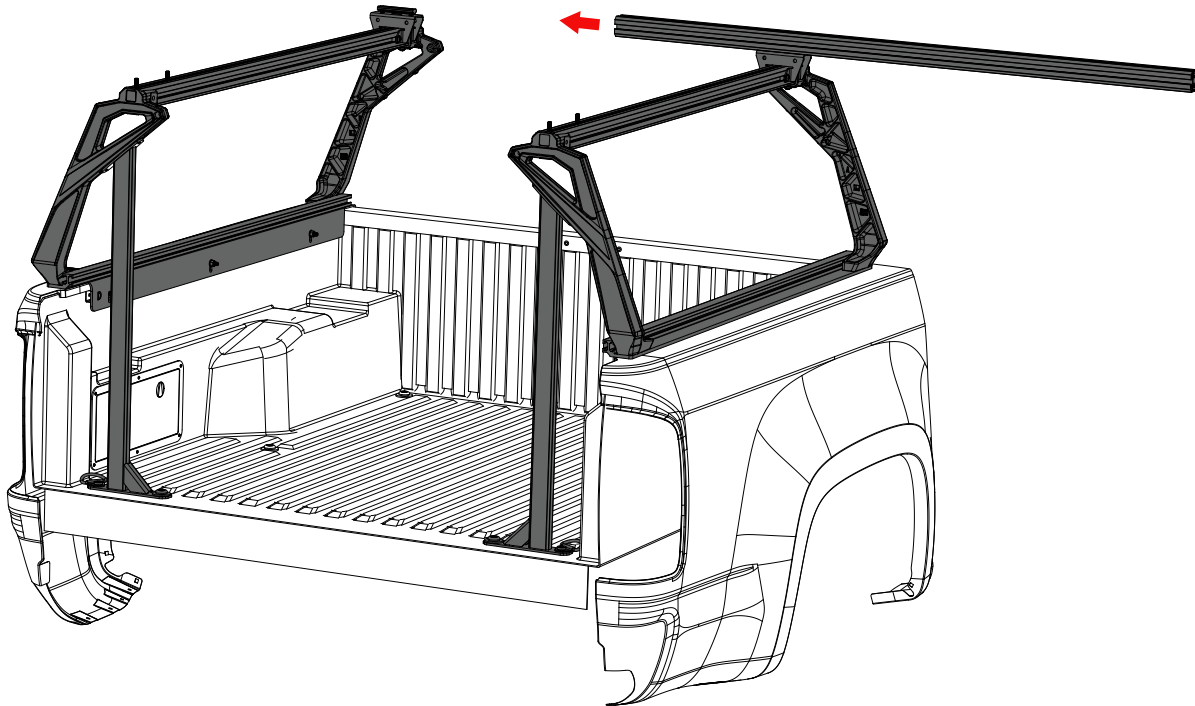

ASSEMBLE: SLIDING LOAD BAR BRACKETS

• USING 2 RUBBER KNOBS PER SIDE, SECURE THE REAR CROSS BAR BRACKET AS FAR REARWARD AS POSSIBLE. [DETAIL A - B]

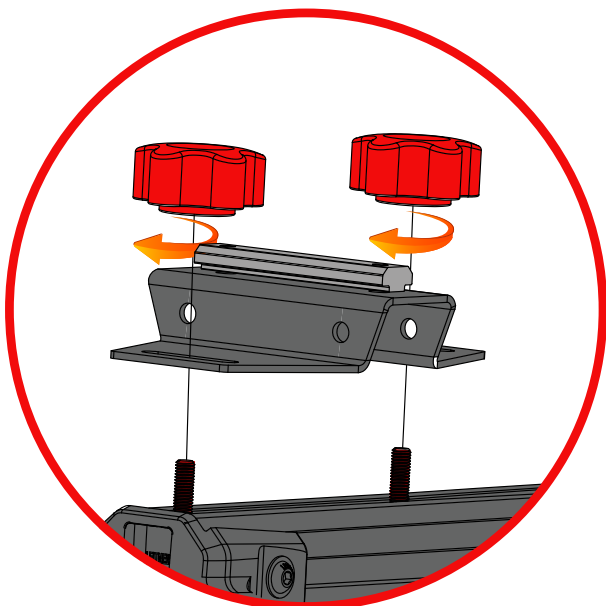
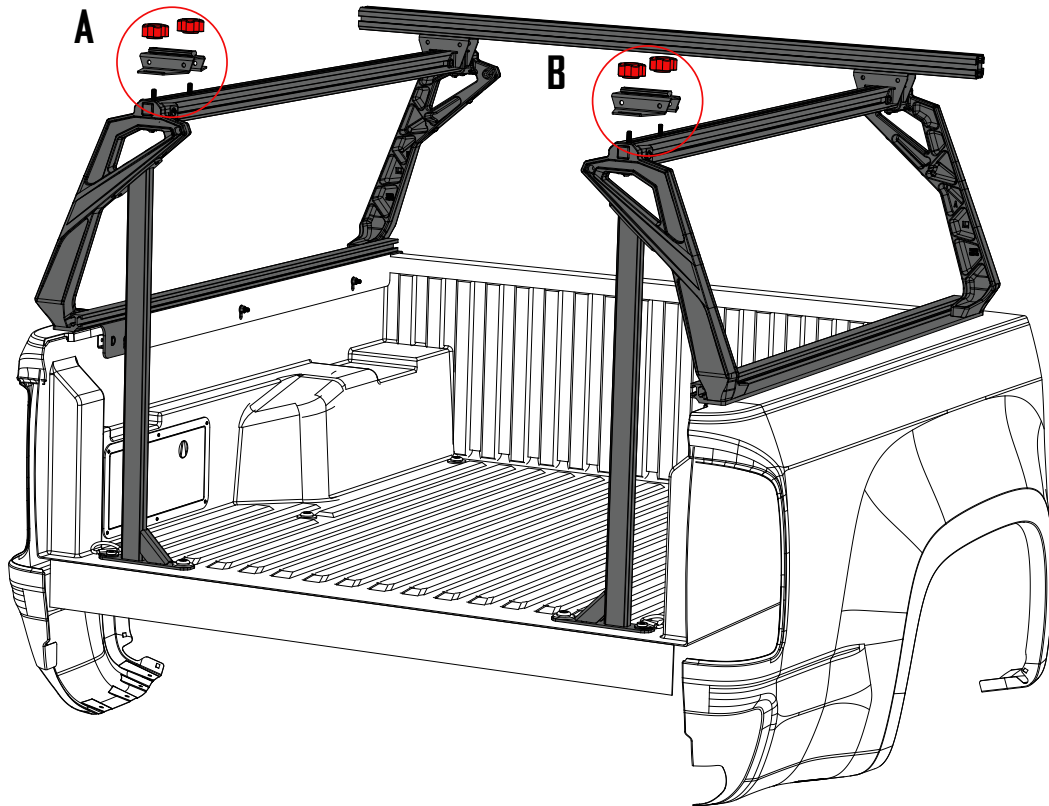

DETAIL-A

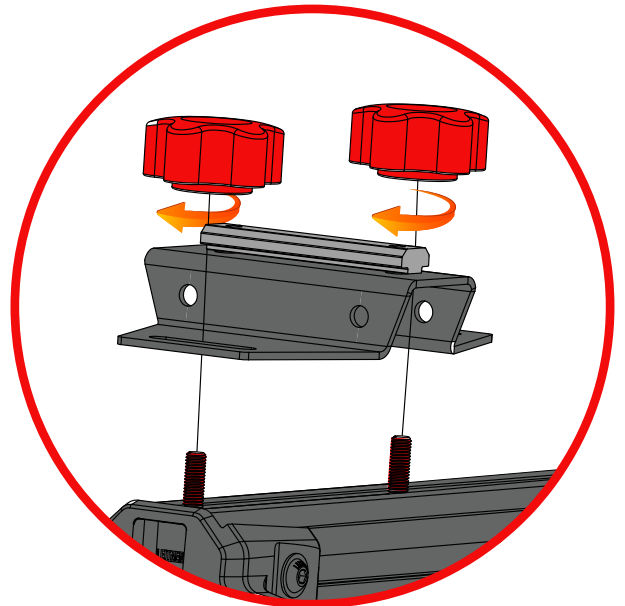

DETAIL-B

ASSEMBLE: REAR LOAD BAR TO BRACKETS

• SLIDE THE 60" LONG LOAD BARS ONTO THE T-NUTS IN THE REAR LOAD BAR BRACKETS AND CENTER THEM ON THE RACK.

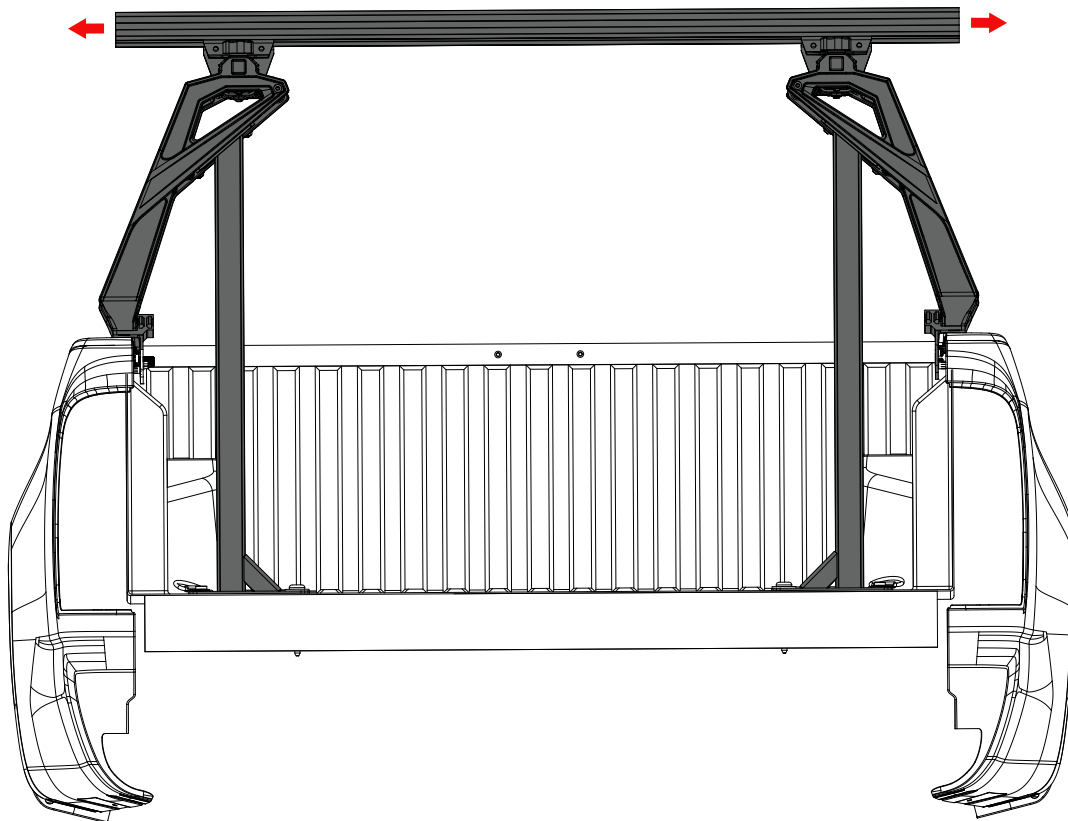
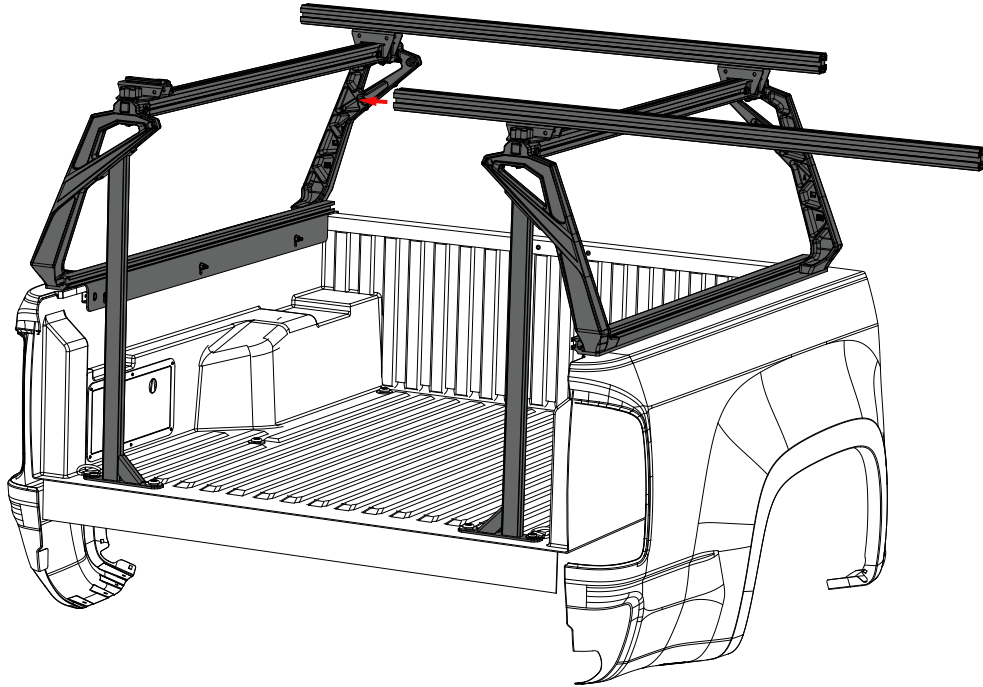

FINISH: INSTALL END CAPS AND RUBBER TREAD STRIP

- INSTALL THE RUBBER TREAD STRIP INTO THE UPPER CROSS BAR CHANNEL BY PUSHING IT INTO THE T-SLOT WITH THE PALM OF YOUR HAND. NOTE: SOME TRIMMING OF THE RUBBER TREAD STRIP MIGHT BE NECESSARY.
- INSTALL THE FOUR END CAPS INTO THE ENDS OF THE CROSS BARS.

CHECK ALL FASTENERS INSTALLED IN PREVIOUS STEPS TO ENSURE THEY ARE PROPERLY TIGHTENED

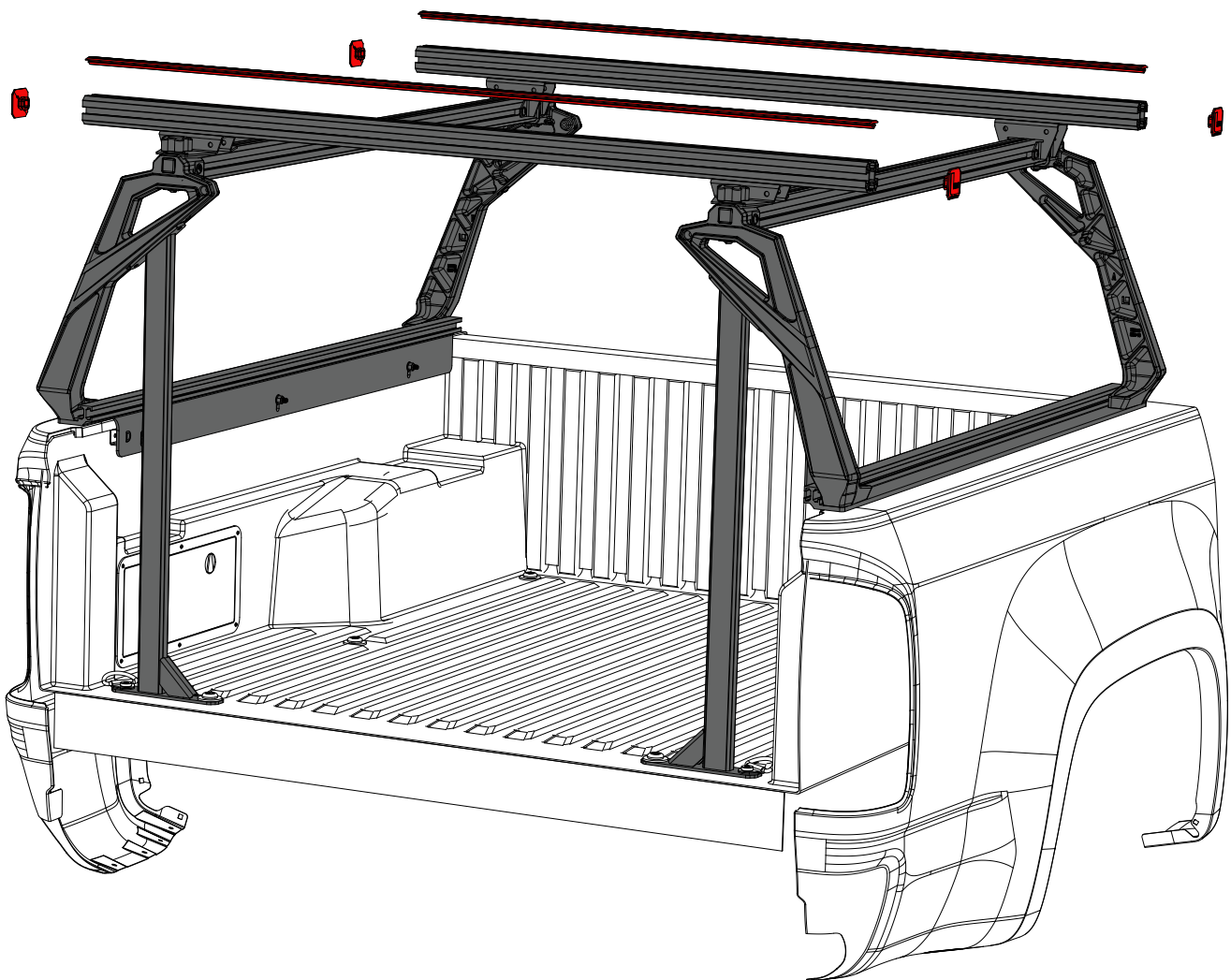

USE GUIDELINES

WHEN USING LEITNER DESIGNS CARRIERS AND ACCESSORIES, THE USER MUST UNDERSTAND THE PRECAUTIONS. THE POINTS LISTED BELOW WILL ASSIST YOU IN USING THE RACK SYSTEM AND WILL ENCOURAGE SAFETY.

-FOR QUALITY FITS AND SAFETY, USE ONLY THE RECOMMENDED RACK OR ACCESSORIES. DO NOT ASSUME A RACK WILL FIT, ALWAYS CHECK THE CURRENT FIT GUIDE WHEN OBTAINING A NEW VEHICLE.

-THE MAXIMUM LOAD IS NOT TO BE EXCEEDED. (250# OFF ROAD – 500# ON ROAD). HOWEVER, THIS LIMIT IS ALWAYS SUBORDINATE TO THE MAXIMUM LOAD RECOMMENDED BY THE MANUFACTURER OF THE VEHICLE ITSELF. IT IS ALWAYS THE LOWER MAXIMUM RECOMMENDED LOAD THAT APPLIES. $\text{MAX TRUCK LOAD} = \text{LOAD CARRIER WEIGHT} + \text{ANY FITTED CARRIER ACCESSORIES} + \text{THE WEIGHT OF THE LOAD ITSELF}$.

-HIGH SPEED OFF ROAD DRIVING EVEN WITH A LIGHT LOAD CAN CAUSE DAMAGE TO THE RACK, ACCESSORIES AND VEHICLE BODY. DAMAGE CAUSED BY HIGH SPEED DRIVING AND ABUSE IS NOT COVERED UNDER WARRANTY.

-MAKE SURE ALL KNOBS, BOLTS, SCREWS, STRAPS, AND LOCKS ARE FIRMLY ATTACHED, TIGHTENED AND LOCKED BEFORE EVERY TRIP. KNOBS, BOLTS, SCREWS, STRAPS AND LOCKS MUST BE PERIODICALLY INSPECTED FOR SIGNS OF WEAR, CORROSION, AND FATIGUE. CHECK YOUR LOAD AT STOPS DURING THE TRIP TO ENSURE CONTINUED FASTENING SECURITY.

-CHECK LOCAL AND STATE LAWS GOVERNING PROJECTION OF OBJECTS BEYOND THE PERIMETER OF A VEHICLE. BE AWARE OF THE WIDTH AND HEIGHT OF YOUR CARGO SINCE LOW CLEARANCE BRANCHES, BRIDGES, AND PARKING GARAGES CAN AFFECT THE LOAD. ALL CARGO WILL AFFECT THE VEHICLE'S DRIVING BEHAVIOR. NEVER DRIVE WITH ANY LOCK, KNOB OR RACK IN AN OPEN OR UNLOCKED POSITION. ALL LONG LOADS SUCH AS, BUT NOT LIMITED TO, SAILBOARDS, SURFBOARDS, KAYAKS, CANOES, AND LUMBER MUST BE TIED DOWN FRONT AND REAR TO THE BUMPERS OR TOW HOOKS OF THE VEHICLE.

-ALL LOCKS MUST BE TURNED AND MOVED PERIODICALLY TO ENSURE SMOOTH OPERATION. USE GRAPHITE OR DRY LUBRICANT TO HELP THIS. LEITNER DESIGNS LOCKS ARE DESIGNED TO DETER VANDALISM AND THEFT BUT SHOULD NOT BE CONSIDERED THEFT PROOF. REMOVE VALUABLE GEAR IF YOUR VEHICLE IS UNATTENDED FOR AN EXTENDED PERIOD. PLACE AT LEAST ONE KEY IN THE GLOVE COMPARTMENT.

-FOR SAFETY TO YOUR VEHICLE AND RACK SYSTEM, OBEY ALL POSTED SPEED LIMITS AND TRAFFIC CAUTIONS. ADAPT YOUR SPEED TO THE CONDITIONS OF THE ROAD AND THE LOAD BEING CARRIED.

-DO NOT USE LEITNER DESIGNS LOAD CARRIERS AND ACCESSORIES FOR PURPOSES OTHER THAN THOSE FOR WHICH THEY WERE DESIGNED. DO NOT EXCEED THEIR CARRYING CAPACITY. FAILURE TO FOLLOW THESE GUIDELINES OR THE PRODUCT'S INSTRUCTIONS WILL VOID THE WARRANTY.

WARRANTY

LEITNER DESIGNS WARRANTS PRODUCT TO BE FREE FROM DEFECTS IN MATERIAL AND WORKMANSHIP, FOR TERMS SPECIFIED BELOW, PROVIDED THERE HAS BEEN NORMAL USE AND PROPER MAINTENANCE. ALL REMEDIES UNDER THIS WARRANTY ARE LIMITED TO THE REPAIR OR REPLACEMENT OF ANY ITEM FOUND BY THE FACTORY TO BE DEFECTIVE WITHIN THE TIME PERIOD SPECIFIED. IF YOU HAVE A WARRANTY CLAIM, FIRST YOU MUST CALL OUR FACTORY AT THE NUMBER BELOW FOR INSTRUCTIONS. YOU MUST RETAIN PROOF OF PURCHASE AND SUBMIT A COPY WITH ANY ITEMS RETURNED FOR WARRANTY WORK. UPON COMPLETION OF WARRANTY WORK, IF ANY, WE WILL RETURN THE REPAIRED OR REPLACED ITEM OR ITEMS TO YOU FREIGHT PREPAID. DAMAGE TO OUR PRODUCTS CAUSED BY ACCIDENTS, FIRE, VANDALISM, NEGLIGENCE, MIS-INSTALLATION, MISUSE, ACTS OF GOD, OR BY DEFECTIVE PARTS NOT MANUFACTURED BY US, IS NOT COVERED UNDER THIS WARRANTY.

THE WARRANTY TIME PERIOD IS AS FOLLOWS: (2) TWO YEARS FROM DATE OF PURCHASE.

HIGH SPEED OFF ROAD DRIVING EVEN WITH A LIGHT LOAD CAN CAUSE DAMAGE TO THE RACK, ACCESSORIES AND VEHICLE BODY. DAMAGE CAUSED BY HIGH SPEED OFF ROAD DRIVING AND ABUSE IS NOT COVERED UNDER WARRANTY.

ANY IMPLIED WARRANTIES OF MERCHANTABILITY AND/OR FITNESS FOR A PARTICULAR PURPOSE CREATED HEREBY ARE LIMITED IN DURATION TO THE SAME DURATION AND SCOPE AS THE EXPRESS WRITTEN WARRANTY. OUR COMPANY SHALL NOT BE LIABLE FOR ANY INCIDENTAL OR CONSEQUENTIAL DAMAGE.

SOME STATES DO NOT ALLOW LIMITATIONS ON HOW LONG AN IMPLIED WARRANTY LASTS, OR THE EXCLUSION OR LIMITATION OF INCIDENTAL OR CONSEQUENTIAL DAMAGES, SO THE ABOVE LIMITATIONS OR EXCLUSIONS MAY NOT APPLY TO YOU. THIS WARRANTY GIVES YOU SPECIFIC LEGAL RIGHTS, AND YOU MAY ALSO HAVE OTHER RIGHTS THAT VARY FROM STATE TO STATE.

FOR WARRANTY ISSUES WITH THIS PRODUCT PLEASE CALL LEITNER DESIGNS CUSTOMER SERVICE **949-395-3049** OR EMAIL US AT **SALES@LEITNERDESIGNS.COM**