



Digital Dimmer Install Instructions

(Part #'s: 21005)

PARTS / TOOLS NEEDED:

				
Dimmer Switch	Bezel & Knob (Optional)	Mounting Screws	Power Drill	Wire Nuts (not provided)

Safety Instructions

- Disconnect power before installing, adding or changing any component.
- To avoid a hazard to children, account for all parts and destroy all packing materials.
- Do not install any luminaire assembly closer than 6" from any combustible materials.
- Positive (+) outputs require a fuse if the attached wire leads are not rated to handle the max current.

1. Determine the installation location for your switch and cut a 1-1/2" x 2" hole using a drywall saw.



2. Using wire nuts attach the units' power to the wires labeled input and attach the output side to your selected light fixture (Figure 1).

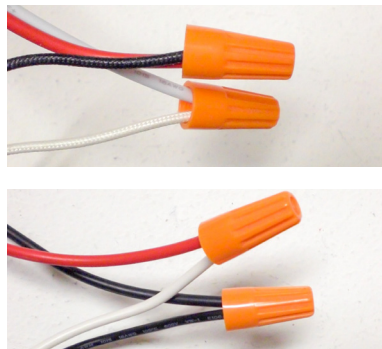

3. Feed wires back through the hole and screw the switch in place using the screws provided.



4. To attach the bezel, first remove the black knob. Slide bezel onto switch and install new knob.



Figure 1: Wire the switch based on the wiring diagram below.

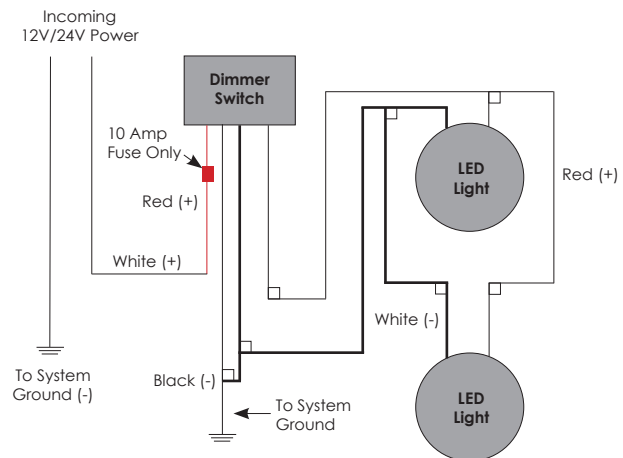

For warranty information please visit www.itc-us.com

3030 Corporate Grove Dr • Hudsonville • MI • 49426

Phone: 616-396-1355 • www.itc-us.com • sales@itc-us.com • Rev C • 10/11/18