

Assembly Instructions for **XTR1 BedRack**



XTRUSION DESIGNS LLC

CONTACT: SUPPORT@XTRUSIONDESIGNS.COM

Thank you for purchasing one of our products. We strive for top quality components and excellent customer service. If you have any issues during installation, don't hesitate to contact us via email at support@xtrusiondesigns.com and we will do everything we can to make sure any issues with our product are resolved!

General Notes:

The assembly instructions depicted below are not truck model specific. However, there will be notes if there are steps that differ from truck models.

Depending on the options that you chose on your rack, the components and hardware may vary. Please refer to your pack list for all contents that are to be included in your kit. If you think you are missing a component, please contact us for further assistance.

Safety First:

We have developed this product with great structural capabilities. However, it is your responsibility to make sure that all nuts and bolts, straps and all adjustable components are always tight and secured. Periodically check the condition of all components including straps, nuts, bolts, knobs, screws and locks to make sure they are free of corrosion, damage, fatigue or wear as any loose components might lead to structural failure and deem the warranty void. Please double check before every trip that there are no loose attachments, hardware, accessories, etc. The system is intended for Off-Road use. If you use on highway roads, it is under your responsibility to ensure its operation is safe. Never exceed the vehicle manufacturer load capabilities, taking precedence over the XTR1 capabilities and taking the weight of the system plus loaded accessories into consideration. All long boards such as kayaks, canoes, surfboards need to be secured to a vehicle attachment point, such as bumper, tow hooks, etc. Remove valuables from vehicle when left unattended for long periods of time.

Always plan your route and check local and state laws governing projection of objects beyond the perimeter of a vehicle. Always be aware of the width and height of your cargo while driving through low clearance obstacles such as bridges, branches, trees, garages, etc.

Obey all posted speed limits and adapt driving to the weather, load and cargo conditions and remember that cargo can affect the vehicle driving behavior.

STEP 1

Check all the components against your pack list. Next, Identify the main components:



*Please note that the components will vary depending on options selected at time of ordering, such as extra Side Braces or Front to Back Braces, and model specific components. Also refer to accessories ordered for installation instructions. **Powder coated components might have small handling marks that would not affect its durability, with exception of sheet metal wing brackets. Pay attention to these and touch up as they are handled.**

Identify the standard hardware components:



Double T-Nut Slide in (DTSN)
For Retrax XR Version Only



Drop-In T-Nuts (DITN) (5/16-18)



1530 End Joint Plates



Button Cap Screw (BCS) (5/16-18)



Socket Head Cap Screw (SHCS) (5/16-18)
(1/4-20) for some optional upgrades.



Hex Head Bolt (HHB) (5/16-18)
(Chevy models only)

*Please note that other optional versions might have additional hardware. Refer to those accessories or options for further detail.

We provide a couple 1.8ml Vibra-Tite® 121 Tubes to coat certain Key pieces of hardware pieces that are in contact with raw aluminum. It is important to only lightly coat 2-3 threads maximum.

STEP 2

Assemble The Columns and Side Braces **with 1530 End Joint Plate included with kit.**

Attach all 1530 End Joints to both ends of all side and top braces. Side and top braces are labeled with **(P# - MBC)** Use the Button Cap Screw **(BCS)** to attach 1530 End Joint to each end of all MBC's.

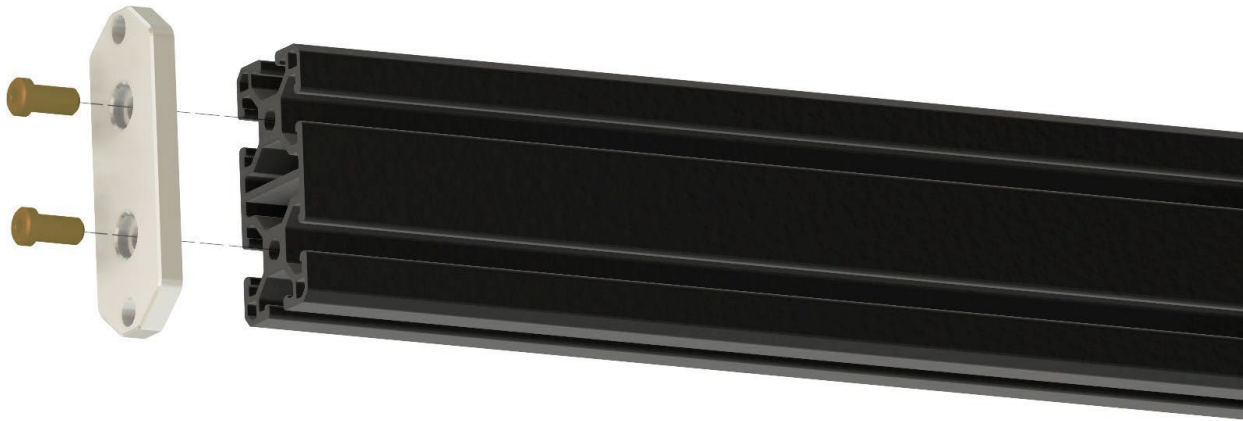

Into one side of each Up Right Column (UPR) Insert Drop-In T-Nuts (DITN) (5/16-18). 2 per each side brace being installed. For a cleaner look, insert each pair of Drop-In T-Nuts (DITN) with bolt holes opposing each other. Otherwise, the long side of the T-Nut will be more visible after installation. Apply thread locker to 3 or 4 threads of the 5/8" Socket Head Cap Screws and attach Main Brace (MBC) to the Column Up Right (UPR).



Completed Side Brace (SBC) Assembly with End Joint method. (Inside of the rack)



STEP 3

Assemble the XTR Corner Brackets (CBR) to the Columns (UPR) using 5/16-18 X 1" long (SHCS) Bolts with Vibra-Tite® 121 Coating and hand tighten 20 Ft-Lbs to 24 Ft-Lbs.

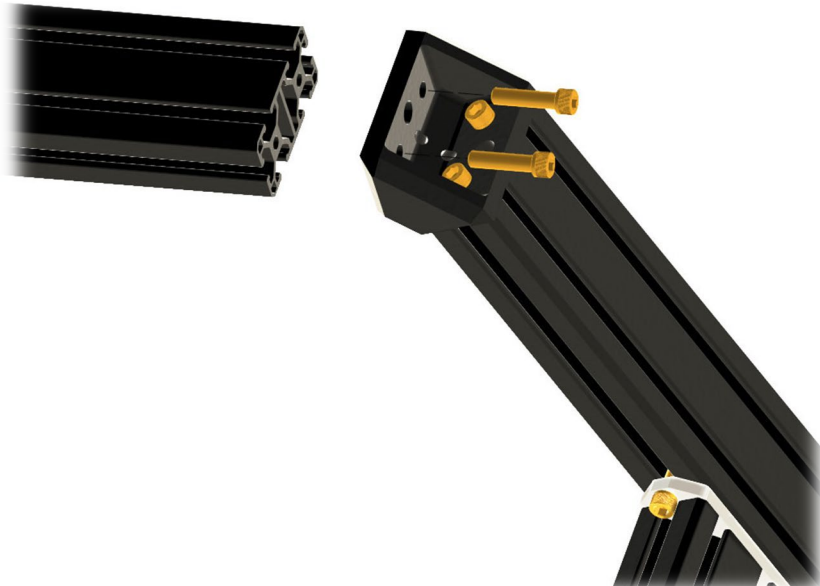

STEP 4

Assemble the Bed Rail Brackets (BRBKT) to the Up Right Columns using 2 ea. Drop-in Trnuts (DITN) on each side of the extrusion and insert the 5/16"-18 x Button Cap Screws.

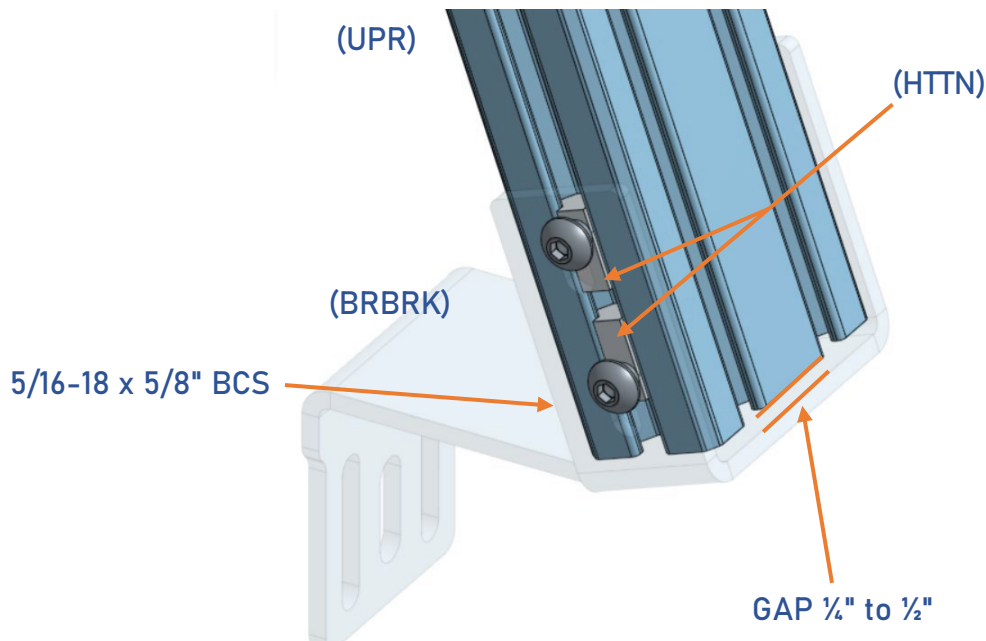

Leave a gap of approx. ¼" to ½" from (UPR) to (BRBKT). This will settle once the rack has been placed on the truck, to adjust for width of assembly.

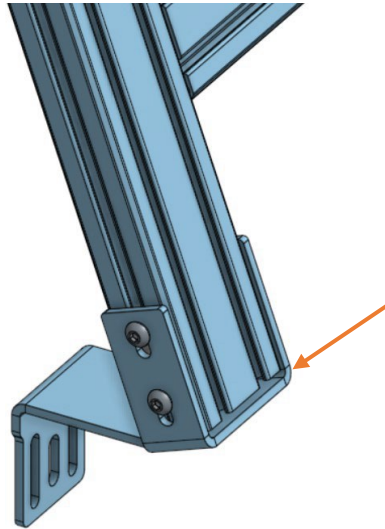

Do not tighten the screws on these brackets, as they will settle once installed into the truck bed. Once in the truck bed and with weight placed, tighten all bracket bolts to Minimum of 20 Ft-Lbs of Torque. Do not Exceed 24 Ft-Lbs.

Columns (UPR) and Main Side Brace (MBC) Assembled with XTR1 Corner Brackets (CBR) and Bed Rail Brackets (BRBKT) Shown below. Repeat Steps for Opposite Side.

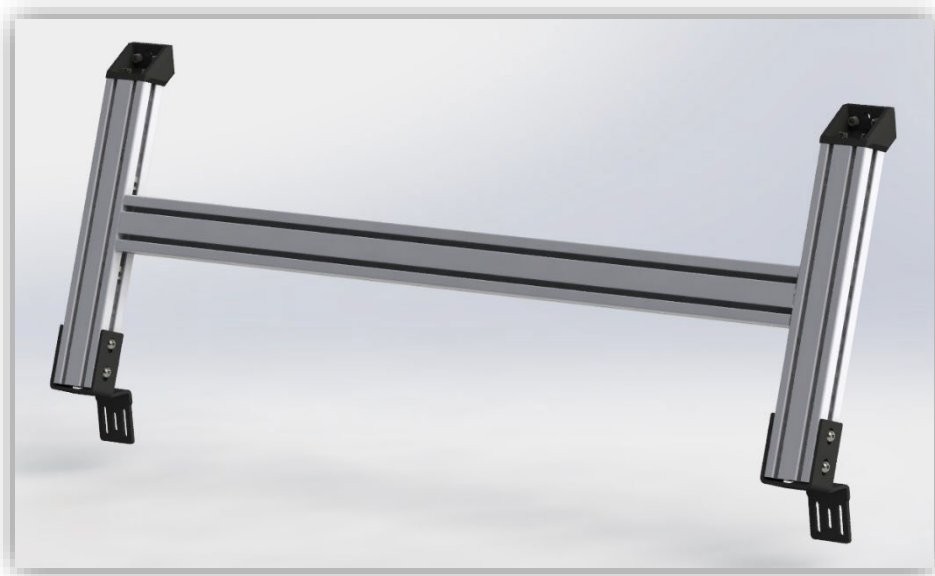

4b RetraxONE XR Bracket Assembly Method (If ordered)

If you ordered your bedrack with the optional RetraxONE® XR Tonneau compatible bracket, the assembly to the bedrail will be slightly different. Follow same steps as Step 4. You will need 8 ea. (DTSN) for the assembly to the RetraxONE® XR rails. Insert 4ea (DTSN) on each side of the RetraxONE® XR rails. Align with the location of the bracket and assemble with the provided washer and 5/16-18 x 1/2" Hex Head Bolts. Do not over tighten. Recommended to use Vibra-Tite® 121 up to 2 threads and use a paint marker to detect if bolts are becoming loose.

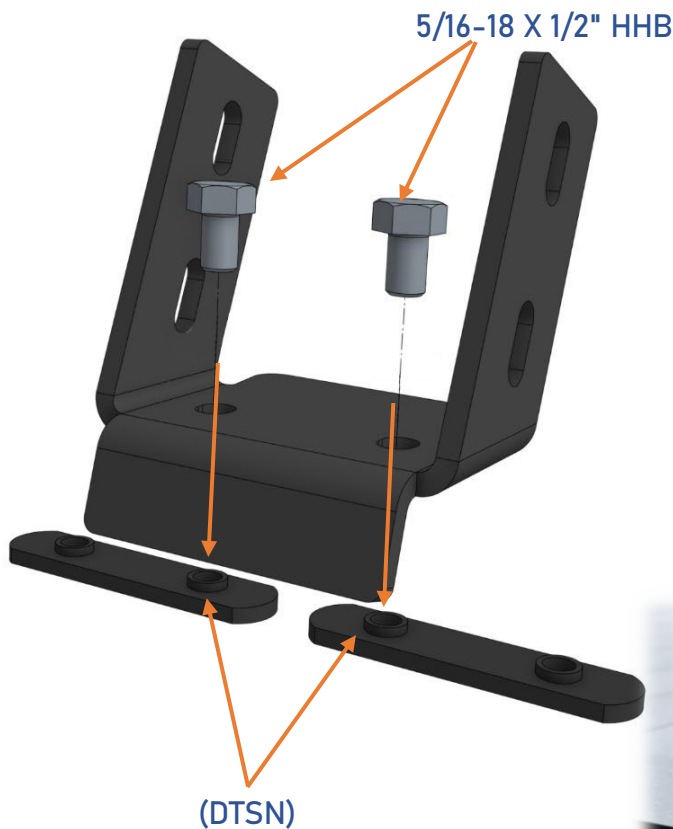

Use the indicated holes.

2 ea DTSN's per Bracket.



STEP 6 – MAIN SUPPORTS ASSEMBLY

Assemble 2 Main Braces (MBC) to one of the Main Cross Brace Bars (CSB). Slide in 2 T-Nuts on each end facing inwards into the rack on MSB's and 2 on each side of the (TSB). Also refer back to Step #2 as these are mounted to the Main Cross Bars in the same way as the side Braces.

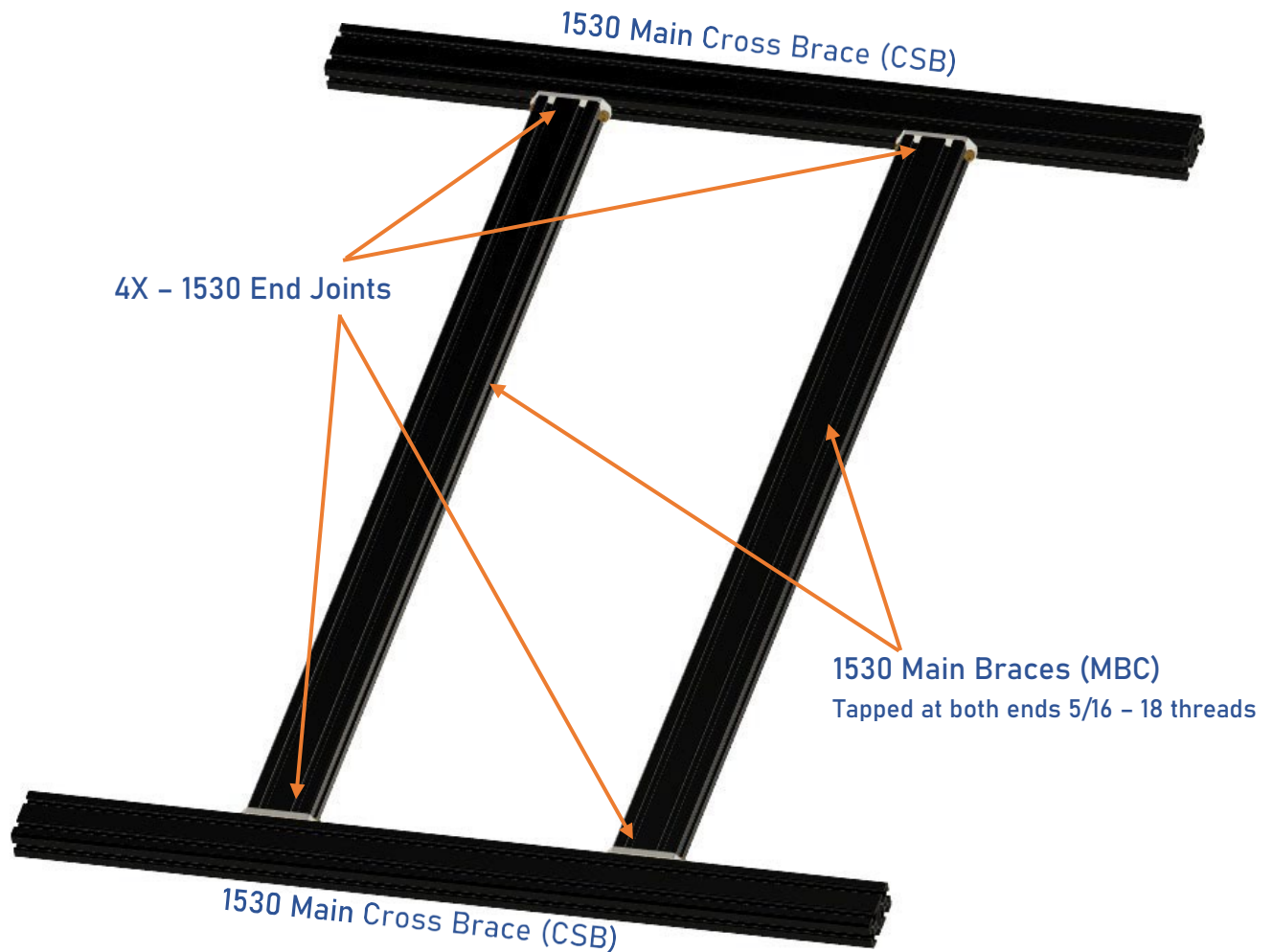

Tighten all bracket bolts to Minimum of 10 Ft-Lbs of Torque. Do not Exceed 15 Ft-Lbs. Please check periodically for tight fit!

STEP 7 – FINAL ASSEMBLY OF ALL COMPONENTS

Place the Main Support Bar Sub-Assembly on a surface such a table, saw horse or any other raised surface. With the help of a friend, assemble both sides of the rack by tightening the 5/16-18 X 1" SHCS from XTR1 Corner Bracket (CBR).

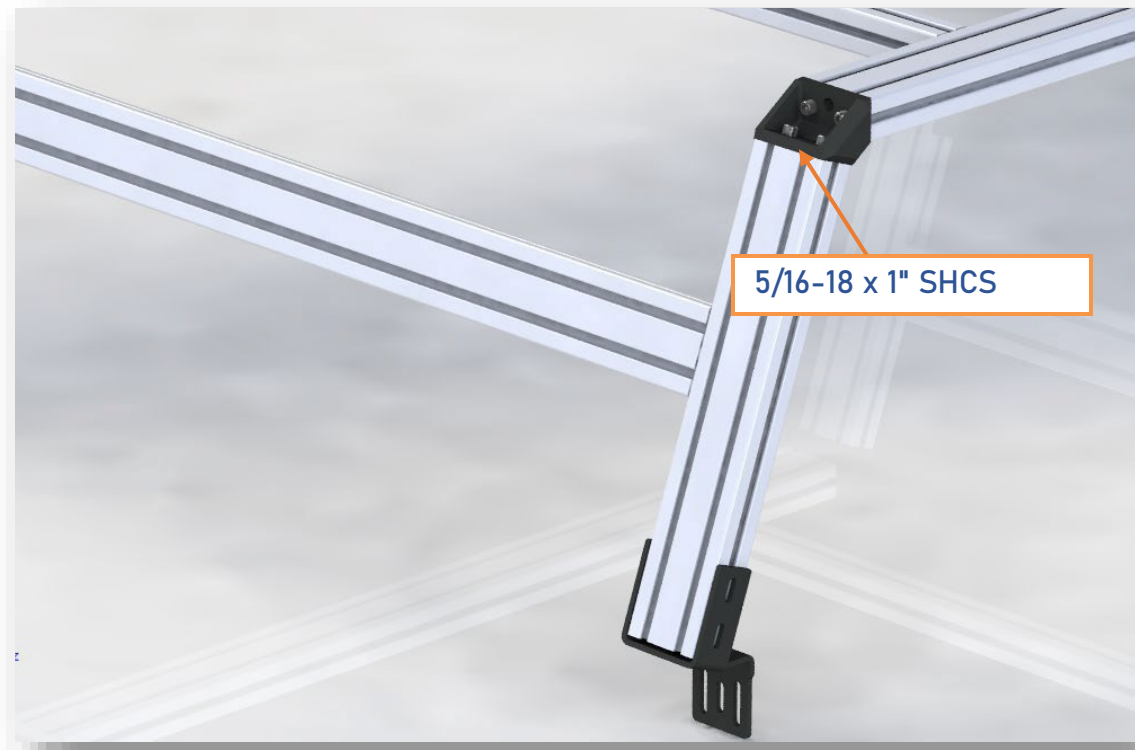

OPTIONAL – “OFF-ROAD REINFORCEMENT PLATES

If you chose the optional OFF-ROAD REINFORCEMENT PLATES from our website (PN: “XTR1-OFFRD4-BLK” OR “XTR1-OFFRD4-SIL”), you can assemble at the end, by inserting 2 Drop In T-Nuts (DITN) on the single side of the Main Cross Bars (CSB) and Column (UPR). Slide in place and tighten with the supplied (5/16-18 X 5/8" BCS) screws. Check orientation of text to your desired side.

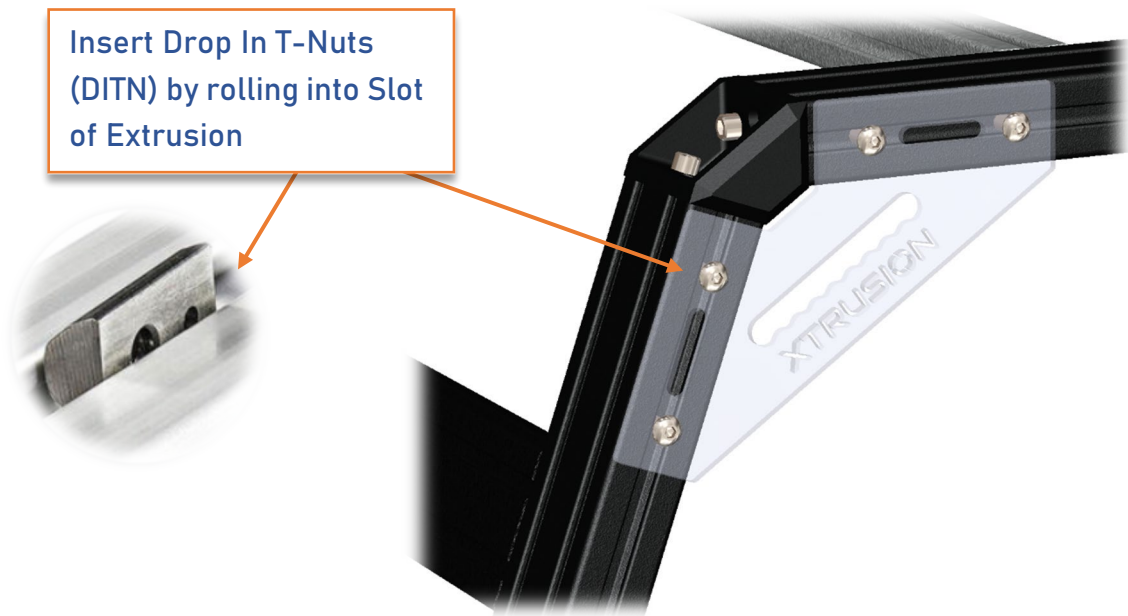

Congratulations, you are almost done. No one said it would be easy. Ok, maybe we did say it was easy. but that is in comparison to the competitor’s racks!

We seriously hope you did not forget to insert your standard T-Nuts wherever slot you wanted to mount stuff. If not, do not worry, we have more drop-in T-Nuts available on our website.

If you have a tonneau cover, you will need to uninstall prior to bed rack installation. The compatible tonneau cover rails would sit on top of our brackets. We advise using a 1/4" foam seal (usually available in major hardware stores) to seal the tonneau rails due to the gap created by our brackets.

Now, let's get back ontrack. With the help of a friend again (sorry, beers not included) take the bed rack assembly and place it on top of the bed rails. **There is some adjustment as depicted below. The height of column on wing bracket will displace the bracket inwards or**

outwards for rack assembly width. This is by design to have a tolerance built in. Usually, a 1/4" gap between Column and Bracket is average.

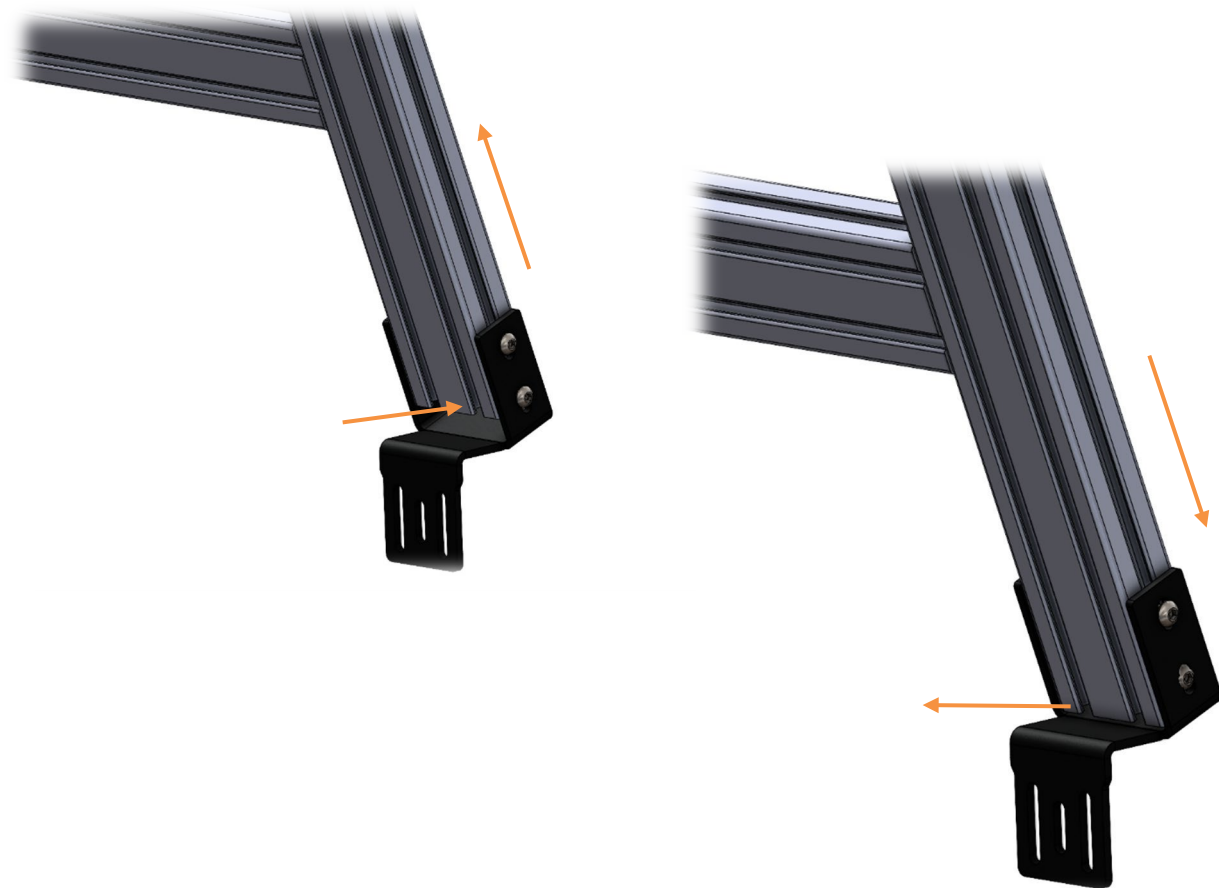

STEP 8 – ASSEMBLY OF BEDRACK INTO TRUCK'S BED

Secure the (BRBRK) brackets onto the truck's Bed Rails. Insert the Pinch Back Plate (PBP) behind the bracket and secure it with the 5/16-18 X 1-1/4" SHCP. Use Washers and/or locknuts if applicable for your model. Hand tighten, observing PBP deformation. Max torque should not exceed 24 ft-lb.

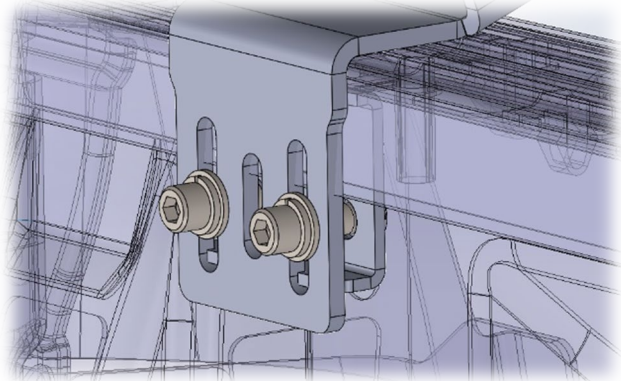
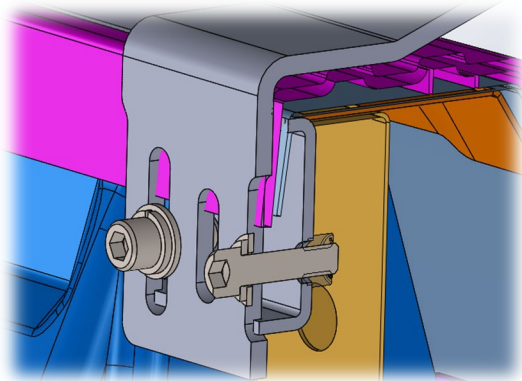

*Alternatively, if you have Toyota, Nissan or Jeep OEM Bed Rail T-Slot and if you selected this option during ordering, you can assemble with the T-Nuts supplied in lieu of (PBP) brackets. * UPDATE* - New version of T-Slot Trail Rail started shipping with bedracks after 6/2021. You might have either a PemSert Stainless Steel backplate or T-Slot Nut as depicted below.*

If you use RetraxONE® XR Brackets, these are assembled into the tonneau rails as explained in step 4b.

LEGACY VERSION - T-NUT

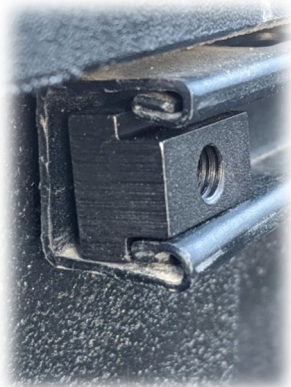

PROPRIETARY NEW
BACKPLATE FOR TRAIL RAIL

**NOTICE ORIENTATION
OF PEMSERTS. INSERT
SCREWS THROUGH
THE FLAT SIDE**

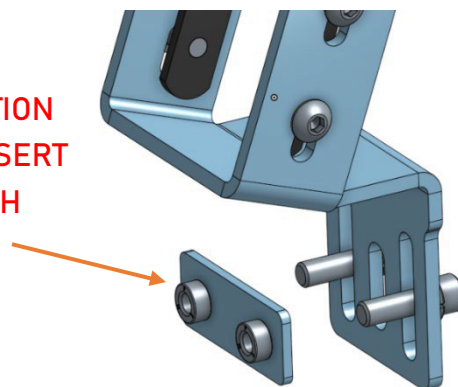

Before you hit the road, check every bolt, screw and attachment. Make sure it's properly tightened. Do not forget to periodically check for loose conditions.

STEP 8a – ASSEMBLY OF BEDRACK FOR CHEVY TRUCKS

Chevrolet Silverado and GMC Sierra models are assembled differently, as they use stake pocket mounts. Some exceptions apply, such as Softopper or shorter bedracks.

For more information about this installation or if you have questions, contact us at support@xtrusiondesigns.com

To assemble the rear stake pockets, use the supplied “L” bracket. Affix to the inner bed side with the supplied 5/16-18 bolt using the fender washer, and a standard washer. Do not tighten yet. Then locate the rear “wing style” bracket. Bolt against the mating surface of the “L” bracket. Do not tighten completely until the bedrack structure is in place.

SILVERADO / SIERRA REAR BRACKET

SUPPLIED “L” BRACKET

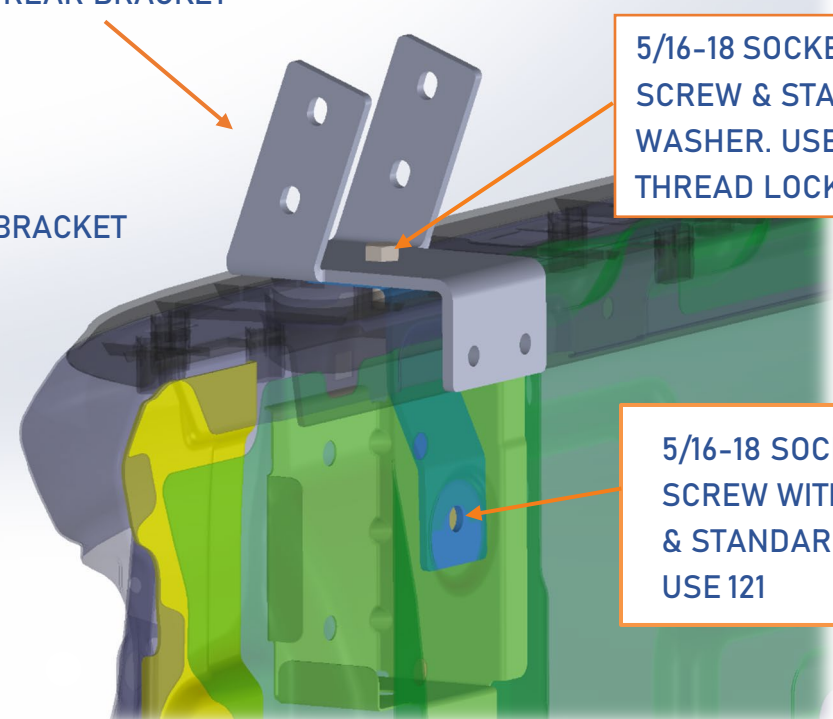

5/16-18 SOCKET HEAD SCREW & STANDARD WASHER. USE 121 THREAD LOCKER.

5/16-18 SOCKET HEAD SCREW WITH FENDER & STANDARD WASHER. USE 121

The brackets near the cabin will have a double nut backplate. On some models you will have to identify and open up the stake pocket area from the bedrail trim. Once you do, insert the supplied long bolt into one of the bedrail bracket holes, and start the threads on the back plate. Slide in the backplate into the stake pocket so that it grips the sheet metal portion of the stake pocket as you pull the bolt up. Use the supplied shorter Hex bolts to

secure the other hole. Remove the long bolt and secure with short bolt. Do not tighten until bedrack structure is in place. Use Vibra-Tite®121 Thread locker.

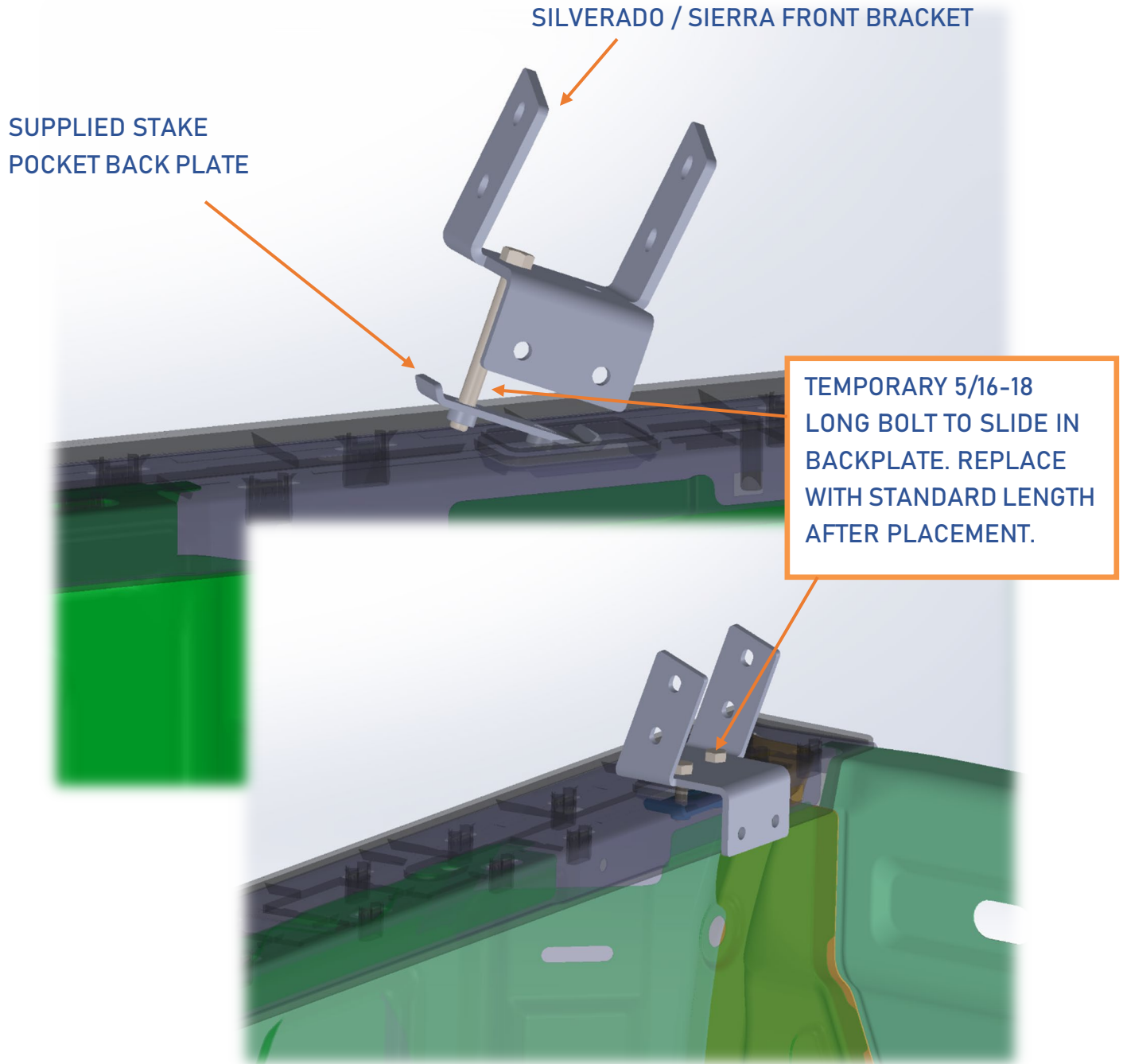



*Rack shown with OPTIONAL 15" XTR Modular Molle Plates. **Available in 2 sizes.** 12" height X 9" wide (for racks between 13" in height and above) and 15" height x 11" wide (for racks 16" in height and above).

ACCESSORIES

Please refer to the Accessories Instructions provided with your purchase. We have several under continuous development! If you would like to see something in particular, let us know!



Notes:

The rack was designed with the latest OEM CAD data. However, every model has tolerances and variances. Additionally, every kit is cut to size and there are thousands of variations for each model. If your rack does not fit into the rails, or if it has a big gap, please contact us to get more details and review options. We will resolve any issue with fitment as soon as possible. Contact us via email to support@xtrusiondesigns.com.

Our racks use a standard 15 series style extrusion, so it is compatible with most manufacturers accessories and components such as Faztek®, 8020 Inc®, Bosch®, etc. You can keep adding and creating structures, at your own risk of damage and/or warranty loss.

WARRANTY

Xtrusion Designs warrants product to be free from defects in material and workmanship, for a period of 1 year, provided there has been normal use and proper maintenance. All remedies under this warranty are limited to the repair or replacement of any item found by the factory to be defective within the time period specified. If you have a warranty claim, first contact us via email to evaluate all options. Warranty applies to original buyer of the rack. You must retain proof of purchase and submit a copy with any items returned for warranty work. Upon completion of warranty work, if any, we will return the repaired or replaced item or items to you freight prepaid. Damage to our products caused by accidents, Fire, vandalism, negligence, mis-installation, misuse, modifications, Acts of God, or by defective parts not manufactured by us, is not covered under this warranty.

Damage or scratches to powder coat paint or anodize finishes that is part of daily use is not covered under this warranty. High speed off road driving even with a light load can cause damage to the rack, accessories and vehicle body. Damage caused by high speed off road driving and abuse is not covered under warranty.

Any implied warranties of merchantability and/or fitness for a particular purposed created hereby are limited in duration to the same duration and scope as the express written warranty. Xtrusion Designs LLC shall not be liable for any incidental or consequential damage. Some states do not allow limitations on how long an implied warranty lasts, or the exclusion or limitation of incidental or consequential damages, so the above limitations or exclusions may not apply to you. This warranty gives you specific legal rights, and you may also have other rights that vary from state to state.

Please contact us at support@xtrusiondesigns.com or call us at 833-987-6837 for any warranty related issues.