



951 SERIES

INTENSE

SERIES

# MANUAL

INTENSE 951 TRAIL

2021

REGISTER YOUR BIKE AT:  
[www.intensecycles.com/pages/registerbike](http://www.intensecycles.com/pages/registerbike)



SCAN ME

FOR TECHNICAL ASSISTANCE:  
Email [info@intensecycles.com](mailto:info@intensecycles.com)  
Phone +1 951-307-9211

9  
FIVE ONE

INTENSE  
**951**  
SERIES

WELCOME TO THE  
INTENSE FAMILY!

CONGRATULATIONS ON  
YOUR NEW INTENSE  
951 TRAIL BIKE!

AT INTENSE WE HAVE  
ONE GOAL -  
TO PROVIDE THE RIDE  
OF YOUR LIFE!

## CONTENTS

04-05	GETTING TO KNOW YOUR BIKE
06-07	GETTING TO KNOW YOUR TOOLS
08-21	SETUP GUIDE
22-23	GOMETRY - GUIDE TO FLIP CHIP
24-25	FRAME SPECS & COMPONENT LIST
26-27	MAINTENANCE
28-29	PARTS LISTINGS
30-31	PARTS KITS





## WHAT ELSE IS IN THE BOX? GETTING TO KNOW YOUR TOOLS

The first thing to do is familiarize yourself with the contents of the toolbox, included in your bike box. If you are confident with tools then great, if you are not, take your time looking through everything and getting to know how each item works. Always make sure you use the correct size tool for the job, making sure that it fits snugly and securely on the bolt, screw or component you are working on. When inserting any bolts, don't rush it, make sure that the thread is going in straight and smoothly, we don't want any cross-threads!

The three main tools that you will use to assemble your bike are: 3-way Y-Wrench Multi-HEX/Allen tool (19), high pressure shock pump (21) and a torque wrench (18). The torque wrench is a tool that stops you from under or over tightening screws, nuts and bolts – that measurement is made in Nm, Newton Meter. Turn the grip/handle of the Torque wrench to the desired setting, then using the correct 'bit' tighten your bolt or screw as normal. When you hear two clicks you have reached the correct torque (tightness) setting. Depending on what they do, different bolts/screws have different torque settings, so be sure to check the correct settings in our setup guide from page 9 onwards.

- |                                |  |
|--------------------------------|--|
| 1. PH1 Philips driver          | 12. 8mm HEX/Allen driver                                   |
| 2. PH2 Philips driver          | 13. T25 Torx driver  |
| 3. Long reach 5mm Allen driver | 14. T30 Torx driver  |
| 4. Torque wrench extension     | 15. T40 Torx driver  |
| 5. 2mm HEX/Allen driver        | 16. 1/4" drive-to-1/4" drive bit adaptor                   |
| 6. 2.5mm HEX/Allen driver      | 17. 1/4" drive-to-3/8" drive adaptor                       |
| 7. 3mm HEX/Allen driver        | 18. Torque Wrench  |
| 8. 4mm HEX/Allen driver        | 19. 3-way Y-wrench Multi-HEX/Allen tool<br>(4mm, 5mm, 6mm) |
| 9. Flat head driver            | 20. Torx 25 tool   |
| 10. 5mm HEX/Allen driver       | 21. INTENSE Shock Pump                                     |
| 11. 6mm HEX/Allen driver       |  |



### WANT TO GO TUBELESS?

Your WTB wheels are tubeless ready and you will find two small bottles of tubeless sealant, one for each wheel contained within the bike box. Go to [intense951.com/pages/techvideos](http://intense951.com/pages/techvideos) for our handy guide on converting your wheels from tubes to tubeless.

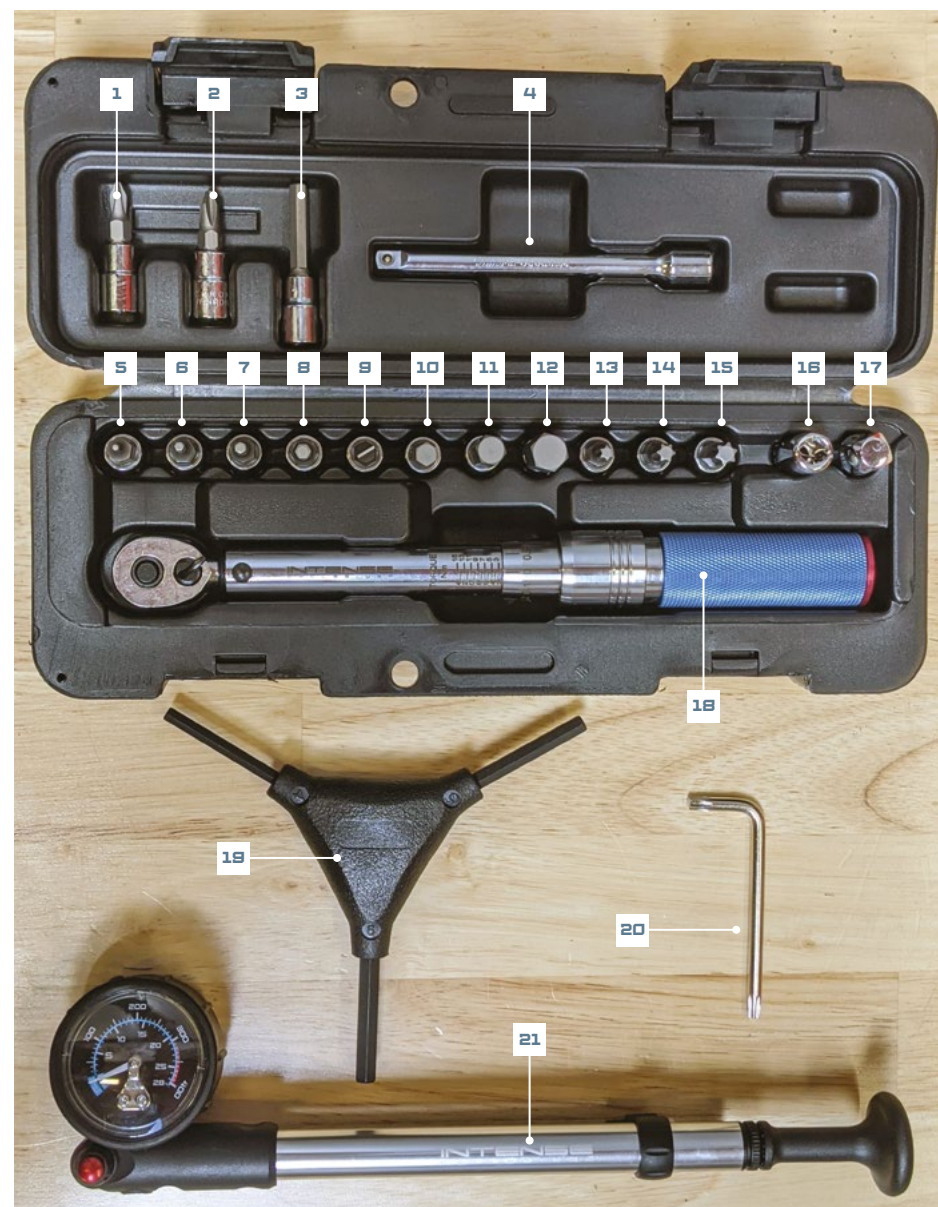





## NEED HELP ?

CALL US AT: +1 951.307.9211  
OR EMAIL: [INFO@INTENSECYCLES.COM](mailto:INFO@INTENSECYCLES.COM)

OUR RIDER SUPPORT TEAM LOOKS FORWARD  
TO HELPING WITH ANY QUESTIONS.

# INTENSE 951 TRAIL SETUP GUIDE

Your new 951 TRAIL is almost ready to go, you just need to do a few things to get your bike ready for the ride. Over the next few pages we'll show you how to assemble your bike. After that, you'll set your saddle height, suspension, and check your tire pressure to ensure a great first ride.

We have a series of in-depth and detailed videos on our website that go through the whole process of building and preparing your bike – including technical videos on suspension set-up, tuning your gears, and much more.

**GO TO [INTENSE951.COM/PAGES/TECHVIDEOS](https://www.intense951.com/pages/techvideos)**

When we talk about the drive-side of your bike we are talking about the side that has the chain and gearing on it. If you were sitting on your bike facing forward this would be the right-hand side. The left-hand side of the bike is known as the non-drive side.

If you own a bike stand, great – just extend the dropper seatpost to its full height (Step 3) and put the bike in the stand. Only use the seatpost to clamp the bike to the stand. For those of you who don't have a bike stand you can use the box the bike came in to help you assemble your bike as outlined over the following pages.

## WE ARE HERE TO HELP!

If at any time you feel unsure about what you are doing then please contact us at:  
INTENSE +1 951.307.9211



## STEP 01

### REMOVE WHEELS AND PREPARE BIKE



**1A** The packaging sections are individually numbered to make it easy for you to remove everything in the right order. The wheels come out first, followed by the rest of the bike. Please keep all packaging for possible future storage or shipping.

**1B** Remove the toolbox and accessories and place nearby. Carefully remove the wheels from the bike box and put to one side. Next, lift up the front end of the bike and hook the fork legs over the box, so that the box acts as a stand.



**2C** Replace the faceplate of the stem and reinsert the bolts, firstly by hand and then with the 4mm Allen key. Gradually tighten the bolts, making sure that the bars are still positioned correctly and that the space between the faceplate and the main body of the stem is even all the way around.



**2D** When tightening the bolts follow this pattern to ensure even clamping: top left, bottom right, bottom left, top right. Finish off using the torque wrench to 5Nm.

## STEP 02

### INSTALL HANDLEBARS



**2A** Remove any packaging on the front of the bike, then spin the handlebar stem 180° so that the stem and forks are facing forward. Make sure that the forks are the correct way around – the front brake caliper should be on the left (non-drive) side of the bike, with the fork arch facing forward.

**2B** Using the 4mm Allen key remove the faceplate of the stem and put the handlebars in place. Use the guidelines printed on the handlebars to help position them centrally and evenly. Check that the brake, gear and dropper post cables have a nice flow and are not kinked or twisted in any way.

## STEP 03

### RELEASE DROPPER, REMOVE BIKE FROM BOX



**3A** Now raise the adjustable seatpost (dropper) to its full height by pressing the lever on the left-hand side of the handlebars. With the saddle (seat) in its fully extended position, you can now pull the bike out of the box.



**3B** Turn the bike over (upside down) so that it is balancing on its saddle and handlebars. It is a good idea to protect your saddle and handlebars with a piece of cardboard or cloth to avoid possible scuffs.

## STEP 04 INSTALL DERAILLEUR



**4A** Move to the rear of the bike and cut off any zip-ties or packaging from the rear derailleur and chain. Using a 5mm Allen key, screw the derailleur into the derailleur hanger/frame.

**4B** At this point be careful that the notch on the 'B screw' is positioned correctly (see above) so that it sits on the flat notch on the hanger. With the torque wrench tighten the main derailleur bolt to 8-9Nm.

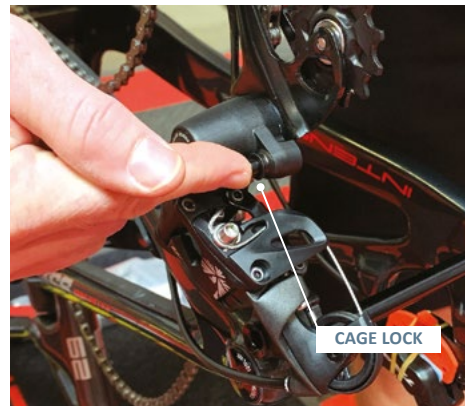
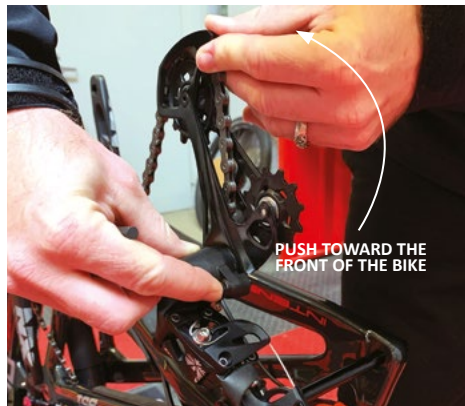

**4C** Holding the bottom of the derailleur cage, (top when upside down) pivot the whole derailleur toward the front of the bike. There will be some resistance from the spring, so be careful that it doesn't 'snap' back into position.

**4D** When it won't go any further forward (in a near vertical position) press the small button with a padlock logo printed on it (Cage Lock). Gently release the derailleur cage. The derailleur should now be locked in position, which will make it easier for you to fit the rear wheel.

## STEP 05 INSTALL THE REAR WHEEL

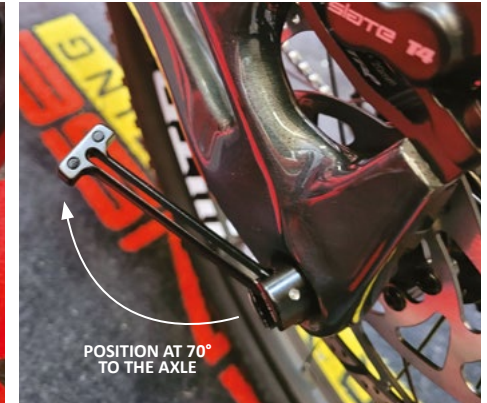

**5A** Remove the orange plastic brake pad spacer. Once this is removed be careful not to squeeze the brake lever until the rear wheel is in position.

**5B** There is an integrated metal lever that sits inside the axle. Pull this out, position at 70° then unscrew and remove the rear axle, keep it close by. Remove any packaging left on the rear wheel, including the large black plastic rotor guards.

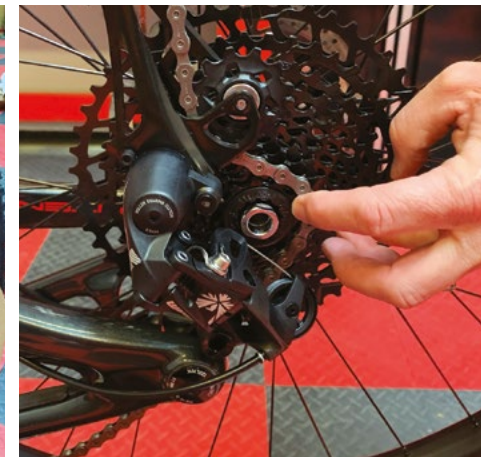
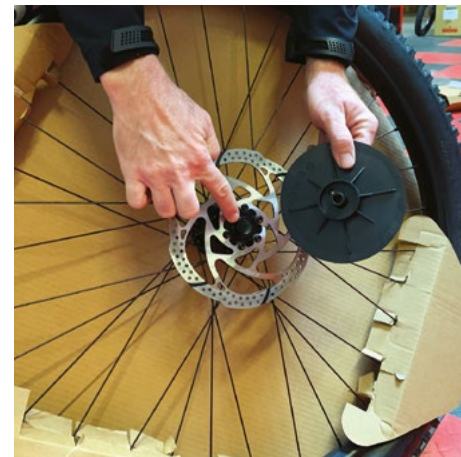

**5C** Be careful that the wheel spacers don't get pulled off by accident. If they do just press them back into position. Do not touch the brake rotors with your hands or gloves, any small amount of grease may contaminate them.

**5D** Position the chain on the smallest cog on the cassette, and carefully line up the rotor with the rear brake caliper making sure that it slides inside (where the orange plastic spacer had been). Make sure the hub end caps drop into the slots on the frame dropouts.





INSERT AXLE FROM THE NON-DRIVE SIDE



PUSH TOWARD THE FRONT OF THE BIKE

**5E** Once everything is lined up and in position, reinsert the axle. Tighten the axle using the integrated lever on the non-drive side (left), turning clockwise until tight. Reinstall the lever within the axle by pushing it firmly back in place. With a 5mm Allen key finish tightening the axle on the drive-side of the bike in a counter-clockwise direction to 11Nm.

**5F** Now take the lock off the rear derailleur. To do this, gently push the derailleur cage forward a little. The derailleur lock is spring loaded, so once the derailleur arm is pushed forward as shown above it will automatically unlock. Slowly let the derailleur arm move backward into its correct position.

## STEP 06 INSTALL THE FRONT WHEEL

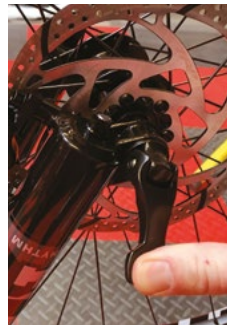

**6A** Remove all packaging from the wheel (make sure the hub end caps are still in the correct place). Then remove the orange brake pad spacer and the front wheel axle from the fork by unscrewing it.

**6B** Position the wheel so that the rotor fits into the brake caliper body and that the hub body slots into the grooves on the fork. When everything is in the correct place reinsert the front wheel axle and tighten, then clamp it tight using the quick release lever. There should be some resistance when the lever is flipped into the vertical position.

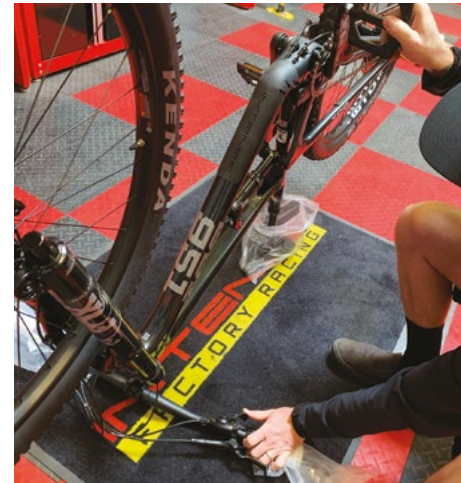

## STEP 07 RUN THROUGH THE GEARS

Now is a good time to run through the gears to check that they are working correctly. To do this turn the cranks (where the pedals are attached) so that the wheel begins to spin, with your hand shift through the gears (being careful not to trap anything in the chain). If you are having any issues with the gears, please check out our Tech Video Series on our website:

[intense951.com/pages/techvideos](http://intense951.com/pages/techvideos)

## STEP 08 ADJUST HEADSET & HANDLEBARS



**8A** It is now time to flip your bike over onto its wheels and check that your headset is adjusted correctly. Set your headset preload at 2-4Nm. Ensure that the headset moves easily with a very slight amount of resistance. If it feels a little loose then undo the stem clamping bolts slightly using a 5mm Allen key and then gently tighten the top cap bolt by a quarter clockwise turn. Retighten the stem clamp bolts and check the headset again. If the bars won't turn smoothly it is too tight, so repeat the process but this time slacken the top cap bolt off a little, or if it is too loose, continue to tighten.

**8B** Once you are happy with your headset adjustment you need to make sure that your stem and handlebars are straight. A good tip is to straddle your bike and look down and line the back of your handlebars up with the front of the fork legs. Take your time to get it right, and when you are happy tighten the two stem bolts to 7Nm using a 5mm Allen.





## STEP 09

### ADJUST SADDLE HEIGHT

Set the height of your saddle (seat) with your seatpost in its fully extended position. Using a 4mm Allen key loosen the seatpost clamp and adjust the seatpost to the correct height. A good base measurement is to stand next to your bike in riding shoes, putting your hand against the top of your hip bone the palm of your hand should be level with the top of the saddle. Adjust as appropriate, then tighten the seat clamp to 4Nm. Do not over tighten this bolt as it may affect the performance of the seatpost.

Note: You may have to slightly readjust the saddle height once you have set up your suspension correctly (Step 12-13).

## STEP 10

### CHECK TIRE PRESSURE

The ideal tire pressure setting is determined by three factors: rider weight, type of terrain and the desired balance of comfort and traction. The pressures here are a suggested starting point and can typically range +/- 5psi. Front: 26psi, Rear 29psi. It is always a good idea to inspect your tires for tears and punctures before and after every ride.

## STEP 11

### BIKE CHECK

You are almost ready to go riding. Now is a good time to check over your bike to make sure that everything looks right – all the packaging is removed, etc. Most importantly you need to check that the brakes are working correctly by spinning the wheels and pulling the brake levers. Check the front brake, then the rear. They should feel firm and strong, and of course stop the wheel from spinning. This is also where you will go over and torque all hardware to the required specifications.

As you get to know your bike you may want to make some small personal adjustments – roll your bars backward or forward a little, position your brake levers at a slightly different angle, adjust your suspension, experiment with tire pressures or slide your saddle backward or forward. This is all perfectly normal, just making small tweaks here and there to really personalize your bike so that it is just right for you.



## STEP 12 FRONT SUSPENSION SETUP

FOX RHYTHM 36 FLOAT  
150 MM. GRIP DAMPER



**12A** The next thing you need to do is set up your suspension. The 951 TRAIL uses air sprung suspension on the front and rear to smooth out the trails. To begin, set the air pressure. Look at the air pressure chart on the right, that will give you a good guide to start from. Remember to calculate your weight when you are in full riding gear, as this will affect your suspension.

**12B** Remove the blue top cap on the left leg of your fork (non-drive side). Underneath you will find a Schrader (car type) valve. Screw on the high-pressure air shock pump that came supplied in the toolkit and pump until you reach the desired pressure.



**12C** You now need to measure the 'sag' of the fork. Sag is important, it allows the fork to work properly. With the help of a friend sit on the bike in a normal riding position, saddle down, pedals level. Bounce up and down on the bike six to seven times and then gently sit back down. On the left leg there is a black rubber O-ring. Get your friend to slide this down until it touches the top of the fork. Carefully get off the bike without compressing the forks further (your friend can help here by holding the handlebars so they don't drop).

**12D** When you are off the bike the fork will extend a little so that there is a gap between the top of the fork leg and the black O-ring. The distance between these two is the sag. You are looking for approximately 20% sag, so for the 140mm (5.5") fork that comes on the 951 TRAIL that measurement should be around 30mm (1.1"). Use a ruler to measure the gap. Adjust the pressure in your forks until you reach the correct sag. Replace the top cap.

The recommended settings below are designed to be a starting point, in order to get you out on your first ride in as few steps as possible. As you ride and get used to your new fork, adjust your settings as explained in step 13.

### SUGGESTED STARTING POINTS FOR SETTING FORK SAG

RIDER WEIGHT (lbs)	RIDER WEIGHT (kgs)	RHYTHM PRESSURE (psi)
120-130	54-59	55
130-140	59-64	59
140-150	64-68	63
150-160	68-73	67
160-170	73-77	72
170-180	77-82	76
180-190	82-86	80
190-200	86-91	85
200-210	91-95	89
210-220	95-100	93
220-230	100-104	97
230-240	104-109	102
240-250	109-113	106

DO NOT EXCEED MAXIMUM AIR PRESSURE: FOX 36 Rhythm maximum air pressure is 120psi.

### SUGGESTED REBOUND SETTINGS

The rebound adjuster for the fork is a red dial (protected by a black plastic cover), it is located on the bottom of the right fork leg. Rebound controls how fast the fork extends after compressing. The rebound adjustment is dependent on the air pressure setting. For example, higher air pressures require more rebound damping. Use your air pressure to find your rebound setting. Turn your rebound knob to the closed position (full clockwise) until it stops. Then back it out (counterclockwise) to the number of clicks shown in the table below.

RIDER WEIGHT (lbs)	RIDER WEIGHT (kgs)	NUMBER OF CLICKS 36 GRIP
120-130	54-59	13
130-140	59-64	12
140-150	64-68	11
150-160	68-73	10
160-170	73-77	9
170-180	77-82	8
180-190	82-86	7
190-200	86-91	6
200-210	91-95	5
210-220	95-100	4
220-230	100-104	3
230-240	104-109	2
240-250	109-113	1

Adjust rebound until (when tested) the fork returns quickly but does not top out. Top out is felt when a fork fully extends too quickly and comes to an abrupt stop when it reaches full extension (you will hear a small noise). Top out should be avoided through proper rebound setting.



### ADJUSTING GRIP COMPRESSION DAMPING

**3-Position Micro Adjust:** The 3-position lever is useful to make on-the-fly adjustments to control fork performance under significant changes in terrain, and is intended to be adjusted throughout the ride. Turning the lever to the full counterclockwise position sets the fork in the Open mode. Turning the lever to the middle position sets the fork in the Medium mode. Turning the lever to the full clockwise position sets the fork in the Firm mode. The positions between the Open, Medium, and Firm modes can be utilized to fine tune your compression damping.

FOX recommends beginning with the 3-position lever in the Open mode.

### REBOUND

**OPEN (counterclockwise)**  
LEAST AMOUNT OF REBOUND DAMPING.  
FORK REBOUNDS **FASTEST**

**CLOSED (clockwise)**  
MOST AMOUNT OF REBOUND DAMPING.  
FORK REBOUNDS **SLOWEST**



# STEP 13

## REAR SUSPENSION SETUP

FOX PERFORMANCE FLOAT DPX2.  
3-POSITION (OPEN, TRAIL, LOCK-OUT)



AIR VALVE CAP. TO UNSCREW TURN COUNTERCLOCKWISE



RUBBER O-RING



Now do the same for the rear shock. The Schrader valve is easier to see, so unscrew the cap and pump it up using the high-pressure air shock pump to the pressure shown in the chart opposite for your weight. Test and adjust as you did for the fork – sit on the bike, saddle down, pedals level. Bounce up and down six to seven times, then gently sit back down, slide the black O-ring up to the shock body, then gently get off the bike and measure the sag until you get around 30% sag. The measurement should be approximately 15mm (0.6") between the black O-ring and the shock body. Replace cap.

### REBOUND

**OPEN** (counterclockwise)  
LEAST AMOUNT OF REBOUND DAMPING.  
SHOCK REBOUNDS *FASTEST*

**CLOSED** (clockwise)  
MOST AMOUNT OF REBOUND DAMPING.  
SHOCK REBOUNDS *SLOWEST*



SHOCK REBOUND DIAL



### COMPRESSION ADJUSTMENTS

The 3-position lever is useful to make on-the-fly adjustments to control shock performance under significant changes in terrain, and is intended to be adjusted throughout the ride.

Use the **OPEN** mode during rough descending, the **MEDIUM** mode for undulating terrain, and the **FIRM** mode for climbing.

### SUGGESTED STARTING POINTS FOR SETTING UP YOUR SHOCK

RIDER WEIGHT (lbs/kgs)	AIR PRESSURE (psi)	REBOUND (clicks out from fully closed) Closed is Clockwise Open is Counterclockwise
100lbs / 45kgs	130	11
110lbs / 50kgs	140	10
120lbs / 54kgs	155	9
130lbs / 59kgs	165	9
140lbs / 63.5kgs	185	8
150lbs / 68kgs	195	8
160lbs / 73kgs	205	7
170lbs / 77kgs	215	7
180lbs / 82kgs	225	7
190lbs / 86kgs	240	6
200lbs / 91kgs	250	6
210lbs / 95kgs	260	5
220lbs / 100kgs	275	4
230lbs / 104kgs	285	3
240lbs / 109kgs	300	2
250lbs / 113kgs	310	2

Proper set up and tuning can vary from shock to shock. Please consult the Fox manual included with your bike for complete information about set up, tuning and general maintenance or visit [ridefox.com](http://ridefox.com)

# GEOMETRY GUIDE TO FLIP CHIP

The 951 TRAIL has a great feature called a 'Flip Chip'. The Flip Chip allows you to alter the geometry of the bike in one of two positions. The 951 TRAIL comes from our factory as standard in the High setting. If you ride terrain that is more downhill orientated or you just prefer your bike to feel slightly more stable on high speed descents then you may want to put it in the Low setting. This all comes down to personal preference, riding style and the type of terrain you normally ride on. Follow the steps below, or check out our Tech Video at [intense951.com/pages/techvideos](http://intense951.com/pages/techvideos)

## HOW TO... FLIP THE CHIP



**01** On the drive-side, use a 5mm Allen key and loosen and remove the drive side RT Nut.

**02** From the non drive-side remove the D-Lock shoulder bolt completely.



**03** On the drive-side, while holding the back of the shock with left hand, loosen the front shock bolt with 4mm Allen key in right hand, push down on rear shock and lower the back of the shock out of the way, then snug the front shock bolt to hold shock and prevent it from hitting on the frame.

**04** Remove the two left and right upper link spacers. Upper link spacers have internal O-rings holding them on to the Flip Chips, they will move once the static friction is broken. Push out the Flip Chips until the Chip head clears the rear triangle. Flip the Chips 180° to the next setting (either High or Low). Reinstall hardware and shock, torque all hardware to corresponding values in table shown on page 29.

# 951 TRAIL

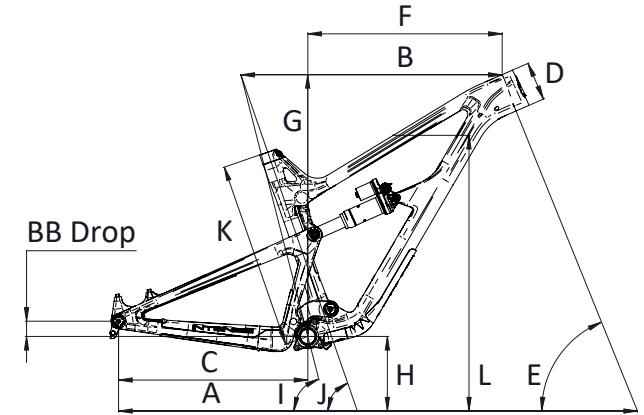

### HIGH SETTING (MM / INCH)

SIZE	SMALL	MEDIUM	LARGE	EXTRA LARGE
WHEELBASE (A)	1170mm / 46"	1200mm / 47.2"	1229mm / 48.4"	1267mm / 50"
TOPTUBE LENGTH (B)	578mm / 22.7"	608mm / 23.9"	636mm / 25"	673mm / 26.5"
CHAINSTAY LENGTH (C)	440mm / 17.3"	440mm / 17.3"	440mm / 17.3"	440mm / 17.3"
HEADTUBE LENGTH (D)	90mm / 3.54"	90mm / 3.54"	100mm / 3.94"	120mm / 4.7"
HEADTUBE ANGLE (E)	65.7°	65.7°	65.7°	65.7°
REACH (F)	411mm / 16.2"	442mm / 17.4"	467mm / 18.4"	497mm / 19.6"
STACK (G)	612mm / 24"	612mm / 24"	622mm / 24.5"	640mm / 25.2"
BB HEIGHT (H)	346mm / 13.6"	346mm / 13.6"	346mm / 13.6"	346mm / 13.6"
BB DROP	29mm / 1.1"	29mm / 1.1"	29mm / 1.1"	29mm / 1.1"
SEATTUBE ANGLE (EFFECTIVE) (I)	75°	75°	75°	75°
SEATTUBE ANGLE (ACTUAL) (J)	70°	70°	70°	70°
SEATTUBE LENGTH (K)	408mm / 16"	431mm / 17"	451mm / 17.8"	476mm / 18.7"
STANDOVER HEIGHT (L)	815mm / 32"	815mm / 32"	819mm / 32.2"	828mm / 32.5"

### LOW SETTING

SIZE	SMALL	MEDIUM	LARGE	EXTRA LARGE
WHEELBASE (A)	1171mm / 46"	1201mm / 47.2"	1230mm / 48.4"	1267mm / 50"
TOPTUBE LENGTH (B)	580mm / 22.7"	610mm / 24"	639mm / 25.1"	675mm / 26.6"
CHAINSTAY LENGTH (C)	441.5mm / 17.4"	441.5mm / 17.4"	441.5mm / 17.4"	441.5mm / 17.4"
HEADTUBE LENGTH (D)	90mm / 3.54"	90mm / 3.54"	100mm / 3.94"	120mm / 4.7"
HEADTUBE ANGLE (E)	65.1°	65.1°	65.1°	65.1°
REACH (F)	405mm / 16"	435mm / 17"	461mm / 18"	491mm / 19.3"
STACK (G)	616mm / 24.3"	617mm / 24.3"	626mm / 24.7"	645mm / 25.5"
BB HEIGHT (H)	339mm / 13.3"	339mm / 13.3"	339mm / 13.3"	339mm / 13.3"
BB DROP	36mm / 1.4"	36mm / 1.4"	36mm / 1.4"	36mm / 1.4"
SEATTUBE ANGLE (EFFECTIVE) (I)	74°	74°	74°	74°
SEATTUBE ANGLE (ACTUAL) (J)	69.5°	69.5°	69.5°	69.5°
SEATTUBE LENGTH (K)	408mm / 16"	431mm / 17"	451mm / 17.8"	476mm / 18.7"
STANDOVER HEIGHT (L)	810mm / 31.9"	809mm / 32"	819mm / 32.2"	822mm / 32.4"



## FRAME SPECS

Model:	INTENSE 951 SERIES TRAIL
Model Year:	2021
Compatible Forks:	150mm Travel
Headtube/Headset:	zs44/28.6 - ec49/40
Frame Seattube Dimensions:	OD 35.6mm (OD = Outside Diameter) ID 31.6mm (ID = Inside Diameter)
Seattube Diameter:	31.6mm
BB Shell Width:	73mm, BSA Threaded
Recommended Max Tire Size:	2.4"
Brakes:	Disc Brake Hydraulic
Max Brake Rotor Size:	203mm (with adapter)
Rear Hub:	148x12mm Through Axle BOOST

NOTE: The 951 TRAIL is designed around the use of a single chainring only. It is not compatible with a double or triple chainring setup.

## SHOCK SPECS

Rear Shock Eye-to-Eye:	210mm
Stroke:	50mm
Mounting Bushing Width Front:	20x6 (6mm reducer)
Mounting Bushing Width Rear:	20x8 (8mm reducer)

## COMPONENT LIST

Model:	INTENSE 951 SERIES TRAIL
Model Year:	2021
Frame sizes available:	Small (S), Medium (M), Large (L) and Extra Large (XL)

FRAME	INTENSE 951 TRAIL 29" 140mm Travel
FORK	FOX Rhythm 36 Float. 150 mm Travel. Grip Damper - Sweep Adj
REAR SHOCK	FOX Performance Float DPX2. 3-position (Open, Trail, Lock-out)
HEADSET	Tange Seiki ZS44-EC49/40
STEM	INTENSE Recon 45mm
HANDLEBARS	INTENSE Recon 780mm width
GRIPS	INTENSE Lock-on
BRAKES	TRP Slate T4 Callipers and Levers, Front and Rear
ROTORS	TRP 180mm. Front and Rear
SHIFTER	SRAM NX Eagle 12sp
DERAILLEUR	SRAM NX Eagle 12sp
CRANKS/CHAINRING	SRAM NX Eagle 32t. ST. 170mm. (S,M,L), 175mm. (XL)
BOTTOM BRACKET	SRAM DUB
CASSETTE	SRAM PG 1230 Eagle 12sp 11-50t
CHAIN	SRAM NX Eagle 12sp
HUBS	INTENSE Alloy
SPOKES	DT
RIMS	WTB ST i30 Alu. 30mm
TIRES	Kenda Regolith 29" x 2.40"
PEDALS	Platform
SEATPOST	INTENSE Recon Dropper 125mm Travel (S), 150mm Travel (M,L), 170mm Travel (XL)
SADDLE (SEAT)	Fizik Terra Alpaca X5, Alloy Rails

### COMPONENT MANUAL ONLINE RESOURCE

We have a full resource available online for all of the parts fitted to this bike. Please visit: [intense951.com/pages/bikemanuals](https://www.intense951.com/pages/bikemanuals) where you will find handy links to the manuals of the components listed above.

# LOOKING AFTER YOUR BIKE MAINTENANCE

You have purchased a high-performance bicycle which requires a certain level of service and maintenance to sustain the level of performance your frame was designed around. Proper care will also ensure the bike is safe to ride at all levels. It is important to read and understand the carbon care information as well as follow the maintenance schedule and inspect your bicycle before each ride. These will not only help to limit or avoid costly repairs but will also help to avoid injury due to service neglect and component failure.

## CARBON CARE

INTENSE, LLC employs advanced composite techniques and material in our frames which do require a certain level of care and maintenance to ensure a safe experience at the high level of performance each frame is designed around. Not following these guidelines will decrease the level of performance and possibly cause injury or death.

- Use a soft cloth with warm soapy water to clean the carbon surfaces. Do not use high pressure washers, abrasive cloths or cleaners.
- Be sure all frame surfaces in contact with cables are protected. Cable housing rubbing on carbon can wear over time.
- Be sure brake levers, handlebar ends and the fork crown do not contact the frame at full rotation.
- Never clamp any part of a carbon frame in a bike stand or car rack.
- Always inspect your frame if you experience any chain suck.
- Always inspect your frame in full after a crash to be sure there is no damage. Look for cracks, dents or loose fibers. If you discover damage in any degree it's best to have your frame inspected by a qualified INTENSE, LLC dealer. Any direct impact to the frame can cause serious structural damage.
- Use high-grade waterproof grease on seat post, BB and headset bearing contact areas with the carbon.
- Never ream or face a carbon frame.
- Be sure to follow all recommended torque settings.
- Use only genuine replacement parts for safety-critical components.

# MAINTENANCE SCHEDULE

	Action	Every Ride	500 Miles or 1 Month	2000 Miles or 6 Months	4000 Miles 1 Year
TIRES	Check air pressure, inspect tread and sidewalls for tears and punctures	X			
CHAIN	Brush off and lubricate	X			
BRAKES	Squeeze brakes and confirm function	X			
GENERAL	Clean complete bike of mud and debris	X			
HEADSET	Check adjustment		X		
BOX LINK	Add grease thru Zerk fittings		X		
FRAME PIVOTS	Check torques		X		
SPOKES	Inspect for damage, check tension		X		
SHOCK & FORK	Check air pressure, inspect for leaks		X		
DERAILEUR	Cables inspect and lube			X	
SEATPOST	Clean and regrease interface with frame			X	
FRAME PIVOTS	Remove pivot bolts, check bearings for pitting and wear			X	
HEADSET	Disassemble stem, headset and fork. Check bearings for pitting and wear			X	
HUBS	Pull wheels off, check hub bearings for pitting and wear			X	
BOTTOM BRACKET	Remove crank arms and check BB bearings for pitting and wear			X	
BRAKES	Replace brake pads			X	
CHAIN	Inspect for damage and check for stretching			X	
GENERAL	Complete Tune-Up				X



# INTENSE 951 TRAIL PARTS LISTINGS

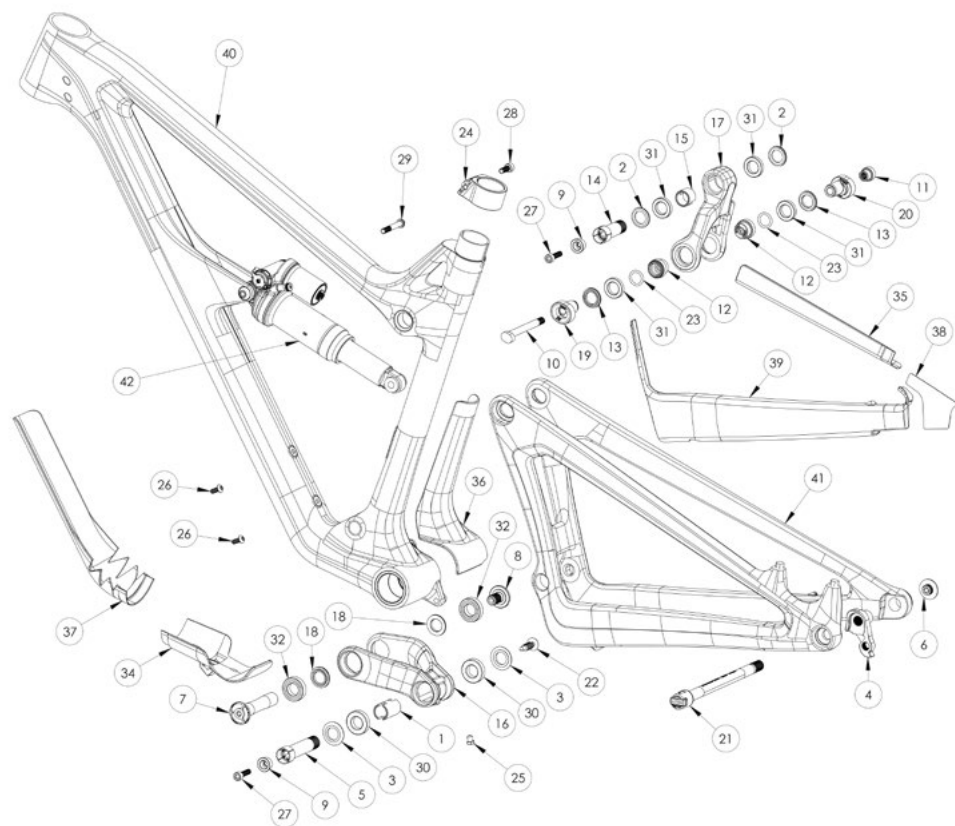

ITEM	PART No.	DESCRIPTION	QTY.	TORQUE SPEC.
1	130758	Crush Tube Lower Link	1	N/A
2	130765	Cap Bearing Blk	2	N/A
3	130778	Cap Bearing Blk	2	N/A
4	130790	Hanger Derailleur Forged Blk	1	N/A
5	130791	Bolt Main Pivot 1.5t Expander Blk	1	7Nm / 60in-lbs
6	130798	RD, Hanger Bolt	1	11Nm / 100in-lbs
7	130800	Axle Lower Pivot	1	20Nm / 175in-lbs
8	130806	Shoulder Bolt Fine Thread Blk	1	20Nm / 175in-lbs
9	130807	Spacer Cone Adjuster Blk, 8.3mm Height	2	N/A
10	130813	RT D-Lock Bolt	1	16Nm / 140in-lbs
11	130814	Drive-side RT Nut	1	16Nm / 140in-lbs
12	130821	Spacer with O-ring groove	2	N/A
13	130835	Cap Bearing Silver	2	N/A
14	130842	Collet Bolt Top Link	1	7Nm / 60in-lbs
15	130847	Crush Tube Top Link	1	N/A
16	130858	Forged Lower Link	1	N/A
17	130859	Carbon Top Link	1	N/A
18	130860	Pivot Axle Spacer	2	N/A
19	130900	Flip Chip RT D-Lock Reducer	1	N/A
20	130901	Flip Chip Drive-side RT Reducer	1	N/A
21	130899	M12 x P1.0 x 172mm (148 x 12mm) QR491, Wheel Axle Kit	1	11Nm / 100in-lbs
22	140038	Push Rivet	1	N/A
23	140044	O-Ring 13.8mm ID x 2.4mm Width	2	N/A
24	340342	Seat Collar	1	N/A
25	401011	Zerk Fitting M6 x 1.0	1	5Nm / 45in-lbs
26	410010	BHCS, Button Head, M5 X 12	2	2Nm / 18in-lbs
27	410032	SHCS, Socket Head, M6 x 22 Titanium	2	14Nm / 125in-lbs
28	410048	SHCS, Socket Head, M6 x 18	2	5Nm / 45in-lbs
29	410050	SHCS, Socket Head, M6 x 40 Titanium	1	7Nm / 60in-lbs
30	430007	Bearing 7902-12S-MAX	2	N/A
31	430008	Bearing 6802-LLU-MAX	4	N/A
32	430009	Bearing 6902-LLU-MAX	2	N/A
33	500300	Decal California Bear	1	N/A
34	500501	Flak Guard Downtube Back	1	N/A
35	500503	Flak Guard Seatstay	1	N/A
36	500504	Flak Guard Seattube	1	N/A
37	500508	Flak Guard Downtube Front	1	N/A
38	500509	Flak Guard Chainstay Clear Protector	1	N/A
39	500517	Flak Guard Chainstay	1	N/A
40	-	951 Trail Front Triangle	1	N/A
41	-	951 Trail Rear Triangle	1	N/A
42	-	Fox Float DPX2 210 x 50	1	N/A

# INTENSE 951 TRAIL

## PARTS KITS

**AXLE KIT** **IT150125** **Axle Kit Rear CNC 148 x 12 Boost With Hidden Lever 951 Series TRAIL**  
 21 130899 M12 x P1.0 x 172mm (148 x 12mm) QR491, Wheel Axle Kit

**BEARING KIT LOWER** **IT340193** **Bearing Rebuild Kit Lower 951 Series TRAIL**  
 1 IT340193 Crush Tube Lower Link  
 30 IT340193 Bearing 7902-1ZS-MAX  
 32 IT340193 Bearing 6902-LLU-MAX

**BEARING KIT UPPER** **IT150106** **Bearing Rebuild Kit Upper 951 Series TRAIL**  
 31 IT150106 Bearing 6802-LLU-MAX  
 15 IT150106 Crush Tube Top Link

**FLAK GUARD KIT** **IT150126** **Frame Protection Flak Guard Kit 951 Series TRAIL**  
 34 IT150126 Flak Guard Downtube Back  
 35 IT150126 Flak Guard Seatstay  
 36 IT150126 Flak Guard Seattube  
 37 IT150126 Flak Guard Downtube Front  
 38 IT150126 Flak Guard Chainstay Clear Protector  
 39 IT150126 Flak Guard Chainstay

**HANGER KIT** **IT340177** **Derailleur Hanger Kit 951 Series XC**  
 4 IT340177 Hanger Derailleur Forged Blk  
 6 IT340177 RD, Hanger Bolt

**HARDWARE KIT LOWER** **IT150025** **Link Kit Lower Hardware Titanium 951 Series TRAIL**  
 3 IT150025 Cap Bearing Blk  
 5 IT150025 Bolt Main Pivot 1.5t Expander Blk  
 7 IT150025 Axle Lower Pivot  
 8 IT150025 Shoulder Bolt Fine Thread Blk  
 9 IT150025 Spacer Cone Adjuster Blk, 8.3 Height  
 18 IT150025 Pivot Axle Spacer  
 22 IT150025 Plug Trim 15mm YF  
 25 IT150025 Zerk Fitting M6 x 1.0  
 27 IT150025 SHCS, Socket Head, M6 x 22 Titanium

**LINK KIT LOWER** **IT150035** **Link Kit Lower Complete Forged 951 Series TRAIL**  
 16 (30,32) IT150035 Forged Lower Link with Bearings

**LINK KIT UPPER** **IT150034** **Link Kit Upper Complete Carbon 951 Series TRAIL**  
 17 (31,15) IT150034 Carbon Top Link with Bearings

**SEAT COLLAR** **IT340210** **Seat Collar Bolted 951 Series TRAIL**  
 24 IT340210 Seat Collar  
 28 IT340210 SHCS, Socket Head, M6 x 18

**HARDWARE KIT UPPER** **IT150024** **Link Kit Upper Hardware 951 Series TRAIL**  
 2 IT150024 Cap Bearing Blk  
 9 IT150024 Spacer Cone Adjuster Blk, 8.3mm Height  
 10 IT150024 RT D-Lock Bolt  
 11 IT150024 Drive-side RT Nut  
 12 IT150024 Spacer with O-ring groove  
 13 IT150024 Cap Bearing Silver  
 14 IT150024 Collet Bolt Top Link  
 19 IT150024 Flip Chip RT D-Lock Reducer  
 20 IT150024 Flip Chip Drive-side RT Reducer  
 23 IT150024 O-ring 13.8mm ID x 2.4mm Width  
 27 IT150024 SHCS, Socket Head, M6 x 22 Titanium  
 29 IT150024 SHCS, Socket Head, M6 x 40 Titanium

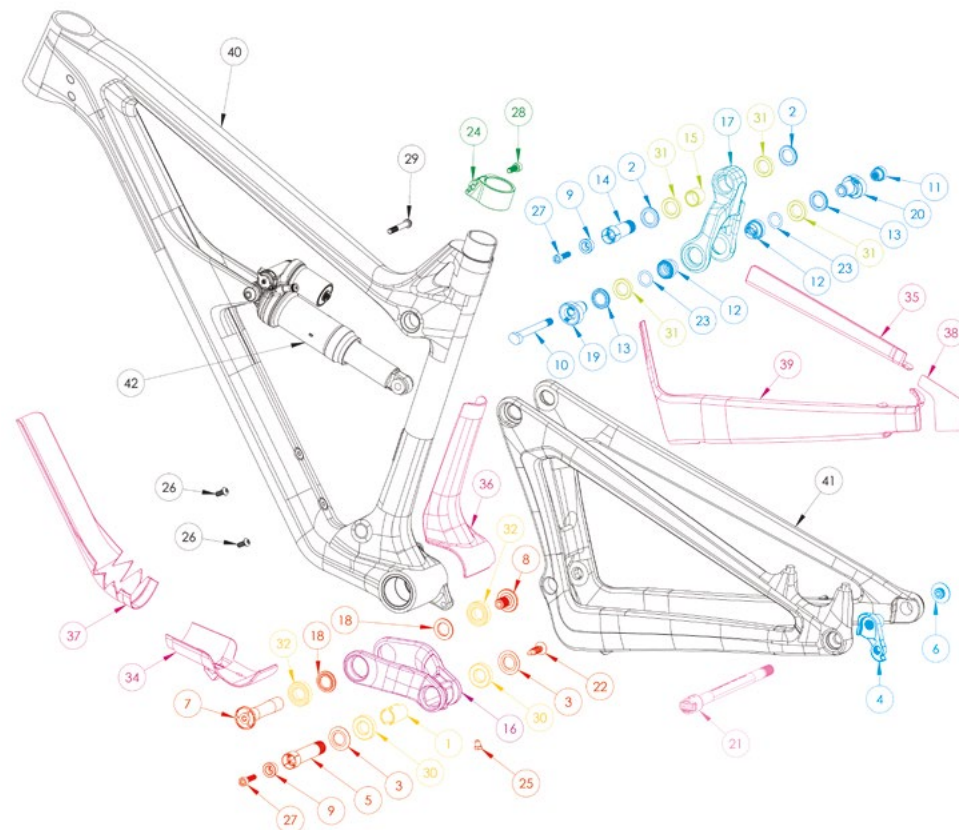





**NEED HELP?**

CALL US AT: +1 951.307.9211  
OR EMAIL: [INFO@INTENSECYCLES.COM](mailto:INFO@INTENSECYCLES.COM)

OUR RIDER SUPPORT TEAM LOOKS FORWARD  
TO HELPING WITH ANY QUESTIONS.

**INTENSE** **951** TRAIL