

Emitter Instruction for RE201, RE202, RE203 series

1. Product Appearance

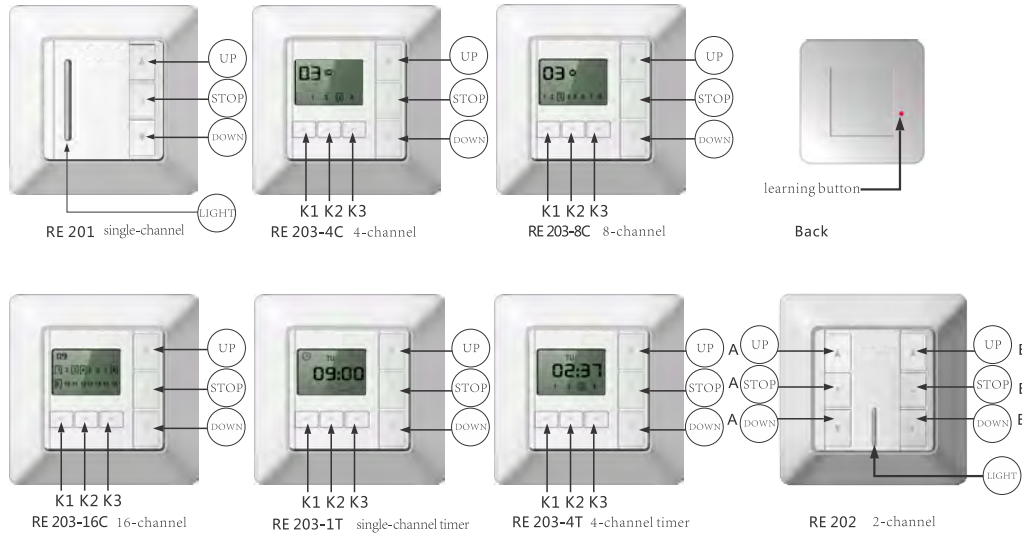

2. Technique Data

- Power: 3V Model: CR2032
- Working Temperature: -10 C to +60 C (LCD)
- Working Temperature: -20 C to +60 C (Non-LCD)
- Working Current: ≤ 12mA
- Code: Rolling Code
- Frequency: 433.92MHz

- 1.wall mount
- 2.panel

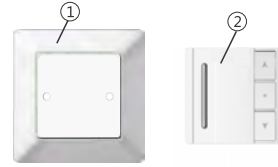

3. Code Learning **Note: Please do not perform code learning in group control mode**

01. Single Channel

Short press the learning button on the back, the code learning is successful.

02. LCD multi-channel (take 8-channel emitter as an example)

The figure on upper left corner of the screen shows the current channel. Short press K1/K3 to choose any channel from 1 to 8.

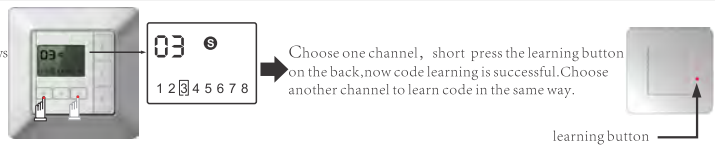

Choose one channel, short press the learning button on the back, now code learning is successful. Choose another channel to learn code in the same way.

03. Two-channel emitter: channel A & channel B control two receivers respectively without interference

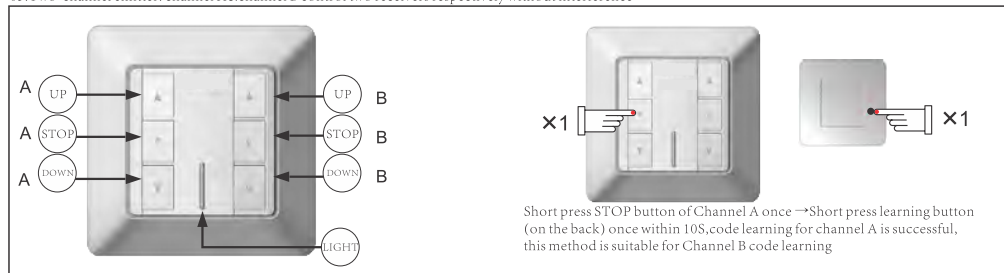

Short press STOP button of Channel A once → Short press learning button (on the back) once within 10s, code learning for channel A is successful, this method is suitable for Channel B code learning

4. Single Control

Select a channel by press K1/K3 as the current channel, then you can control this channel by pressing UP/STOP/DOWN button.

5. Group Control (LCD) Short press K2 to choose Group Control **M** or Single Control **S**.

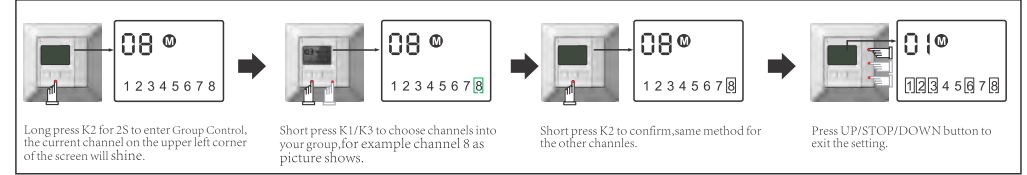

6. Delete Group Control

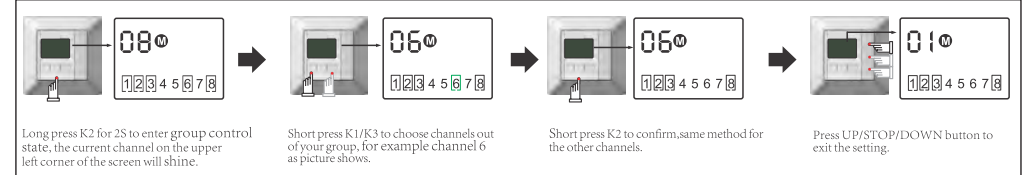

Note: Whether in **M** or **S** mode, the current channel is always selected

7. LCD Four-Channel Timer Emitter

01. Time Setting

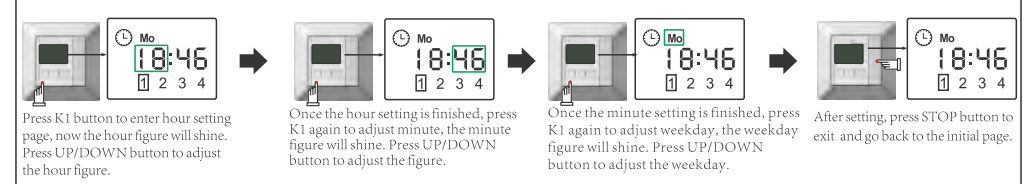

02. Timing Setting (set different time points to make the motor close or open)

In the initial page, press K2 to enter timing setting page, there is a timing clock on the upper left corner. You can respectively set 8 opening time points and 8 closing time points, in total 16 points. Press K2 to cycle among 16 time points. Press K3 to choose the output channels which you want (single channel or 4 channels)

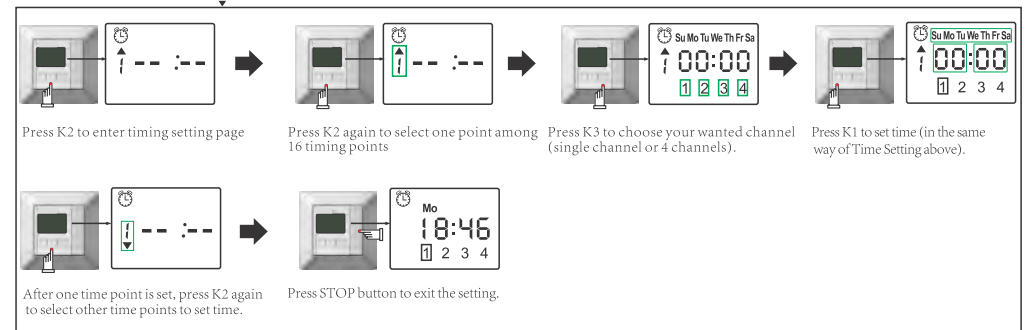

03. Close Timing Function

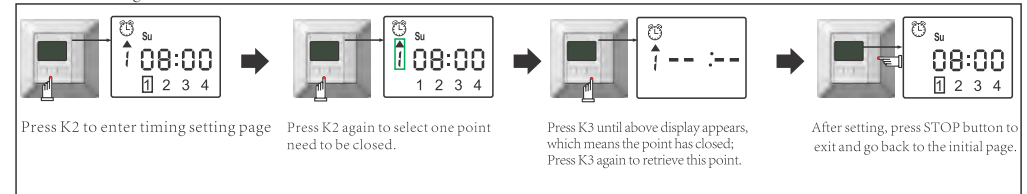

Emitter Instruction for RE201, RE202, RE203 series

8.LCD timer emitter(1-channel)

01.Time Setting

Press K1 button to enter hour setting page, now the hour figure will shine. Press UP/DOWN button to adjust hour figure.

Once the hour setting is finished, press K1 again to adjust minute, the minute figure will shine. Press UP/DOWN button to adjust minute figure.

Once the minute setting is finished, press K1 again to adjust week day, the weekday figure will shine. Press UP/DOWN button to adjust week day.

After setting, press STOP button to exit and go back to the initial page.

02.Timing Setting

In the initial page, press K2 enter timing setting page, there is a timing clock on the upper left corner, You can respectively set 8 opening time and 8 closing time, in total 16 points Press K2 to cycle among 16 time points.

Press K2 to enter timing setting page

Press K2 again to select one point among 16 timing points

Press K3 to enter Time Setting page, then press K1 to set the time points in the same way as above Time Setting.

Once one time point is set, press K2 again to select other time points to set time. When setting finished, press button STOP to exit.

03.Close Timing Function

Press K2 to enter timing setting page

Press K2 again to select one point need to be closed.

Press K3 once to delete the point; Press K3 again to retrieve this point.

After setting, press STOP button to exit and go back to the initial page.

04.Stop Watch Function

In the initial page, press K3 to enter Stopwatch page.

If you want to exit from stopwatch page, press K3 again to go back to initial page.

Note:

- The emitter must enter timing setting page if you want to set timing points. There should be a timing clock on the upper left corner, otherwise, the setting is invalid. If there is no clock on the screen, please hold Stop button and press K2 within 10 seconds, there will be a clock on the upper left corner.
- It is better not to press the emitter's buttons too long so as to prolong the battery's life. The button press should be about 0.5s with 1s interval.
- The emitter will stop working if the battery is in low power. Please replace the battery.

COIN BATTERIES CAN KILL



Our remote controllers contain lithium coin batteries.

WARNING	
<p>KEEP OUT OF REACH OF CHILDREN Swallowing can lead to chemical burns, perforation of soft tissue, and death. Severe burns can occur within 2 hours of ingestion. Seek medical attention immediately.</p>	

If you suspect your child has swallowed or inserted a coin/button battery, call the Australian Poisons Information Centre immediately on **13 11 26** for 24/7 fast, expert advice. If your child is having any difficulty breathing, contact **000** (NZ Poisons Centre 0800 764 766 Emergency 111). Keep new/used coin batteries out of sight and out of reach of children at all times. Dispose old batteries responsibly.