

Dry Contact Input Transmitter



**DRY CONTACT
INPUT**



4.33 MHz



**GROUP
CONTROL**



**SEQUENCE
MODE**

AUTOMATE | Dry contact input transmitter enables most common mechanical switches or automation systems relays to control ARC motorized shades. It functions as a single channel transmitter and accepts dry contact input. Once a motor or group of motors are paired to the transmitter, it converts the dry contact inputs and sends ARC radio commands to trigger those motors to move upward/downward.

FEATURES:

- Interface between third party smart home systems and ARC motors
- Three dry contact inputs
- Wireless signal output
- ARC motor communication protocol
- Group Motor Control
- Four switch modes
- 12V or 24V power source compatible

CONTENTS

1	TECHNICAL DATA / PACK CONTENTS	3
2	SAFETY	4
3	INSTALLATION	5
3.1	Overview	5
3.2	Wire Diagram	5
4	SETTING SWITCH MODE	6
5	ADDING OR DELETING A TRANSMITTER & CREATING A GROUP OF CHANNELS	7
5.1	Using motor P1 button	7
5.2	Using a pre-existing controller	7
6	SWITCH MODE OPERATION	8
6.1	Operation of Normal Switch Mode	8
6.2	Operation of Pulse Switch Mode	9
6.3	Operation of Mechanical Switch Mode	10
6.4	Operation of Sequence Switch Mode	11
6.5	Operation of Favorite Position	12
7	TROUBLESHOOTING	13
	NOTES	14

1 TECHNICAL DATA / PACK CONTENTS

TECHNICAL SPECIFICATIONS	
12V Power Input Voltage:	8V ~ 16V
24V Power Input Voltage:	16V ~ 26V
Radio Frequency	433.92 MHz
Transmitting Power:	10 milliwatt
Ambient Operating Temperature:	-10°C ~ 50°C
	14°F ~ 122°F
Transmission Distance:	up to 200m (open space)
	up to 656' (open space)
Dry Contact Input Duration	>0.25 seconds

PACK CONTENTS

1x contact closure box

1 x instructions

DIMENSIONS

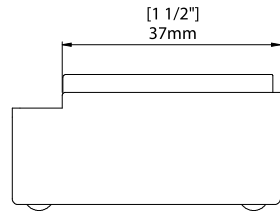
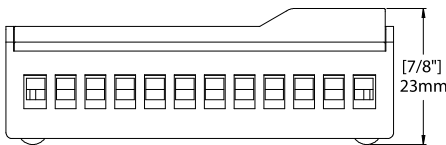
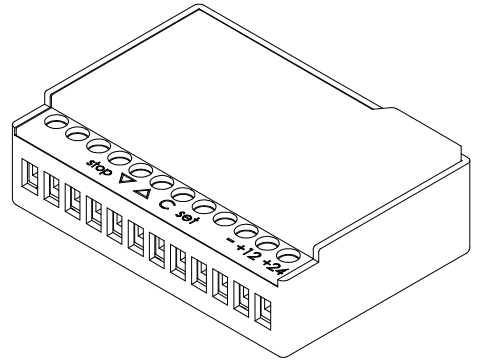
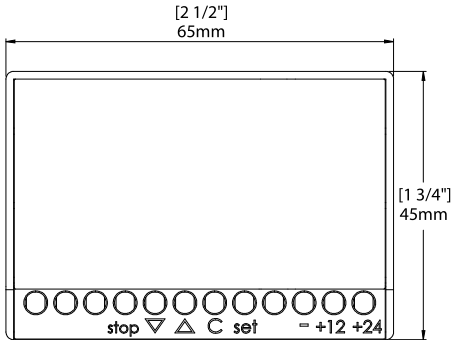

WARNING: Important safety instructions to be read before installation.

Incorrect installation can lead to serious injury and will void manufacturer's liability and warranty.

It is important for the safety of persons to follow the enclosed instructions.

Save these instructions for future reference.

CAUTION

- Do not expose to moisture or extreme temperatures.
- Persons (including children) with reduced physical, sensory or mental capabilities, or lack of experience and knowledge should not be allowed to use this product.
- Use or modification outside the scope of this instruction manual will void warranty.
- Installation and programming to be performed by a suitably qualified installer.
- Follow installation instructions.
- For use with motorized shading devices.
- Keep away from children.
- Frequently inspect for improper operation. Do not use if repair or adjustment is necessary.
- Keep clear when in operation.

Rollease Acmeda declares this equipment is in compliance with the essential requirements and other relevant provisions of R&TT EC Directive 1999/5/EC.

Statement Regarding FCC Compliance

This device complies with Part 15 of the FCC Rules. Operation is subject to the following two conditions:

- (1) This device may not cause harmful interference, and
- (2) This device must accept any interference received, including interference that may cause undesired operation.

Note:

This equipment has been tested and found to comply with the limits for a Class B digital device, pursuant to Part 15 of the FCC Rules. These limits are designed to provide reasonable protection against harmful interference in a residential installation.

This equipment generates, uses and can radiate radio frequency energy and, if not installed and used in accordance with the instructions, may cause harmful interference to radio communications.

However, there is no guarantee that interference will not occur in a particular installation. If this equipment does cause harmful interference to radio or television reception, which can be determined by turning the equipment off and on, the user is encouraged to try correct the interference by one or more of the following measures:

- Reorient or relocate the receiving antenna
- Increase the separation between the equipment and receiver
- Connect the equipment into an outlet on a circuit different from that to which the receiver is connected
- Consult the dealer or an experienced radio/TV technician for help

Any changes or modifications not expressly approved by the party responsible for compliance could void the user's authority to operate the equipment.



Do not dispose of in general waste.
Please recycle batteries and damaged electrical products appropriately.



3 FUNCTIONAL OVERVIEW

3.1 Overview

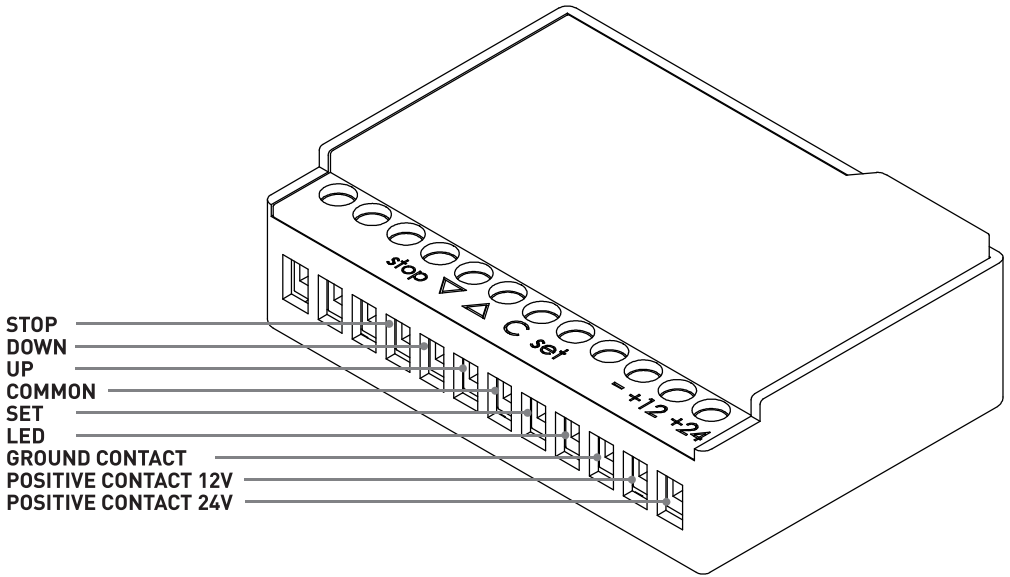

3.2 Wiring Diagram

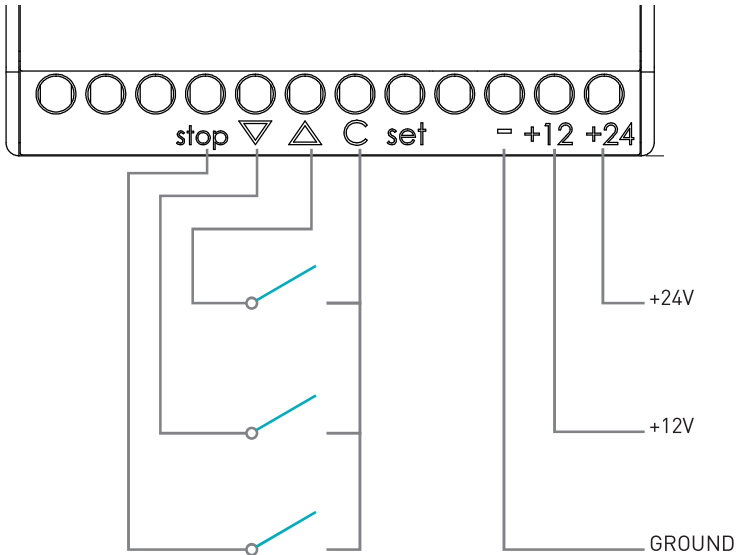

NOTE: Only one positive power point, +12V or +24V, is needed.

4 SETTING SWITCH MODE



IMPORTANT

The **SET** button is utilized to choose the working mode of the dry contact input transmitter as described below:



Continuously hold **SET** button and release when the desirable switch mode is achieved.

LED flashing indicates switch mode type.

NORMAL SWITCH MODE

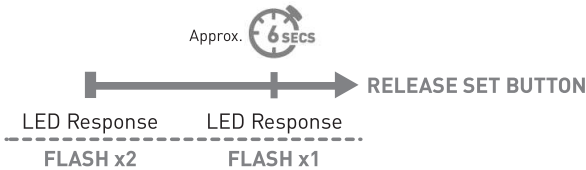

PULSE SWITCH MODE

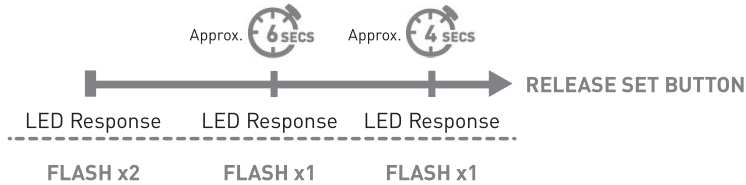

MECHANICAL SWITCH MODE

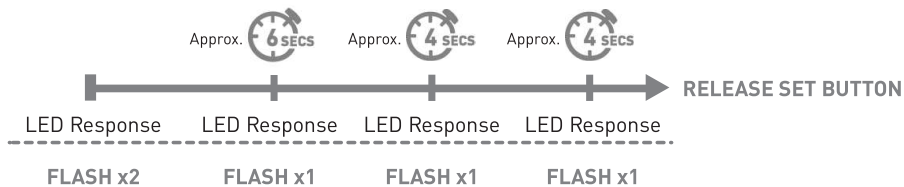

SEQUENCE SWITCH MODE

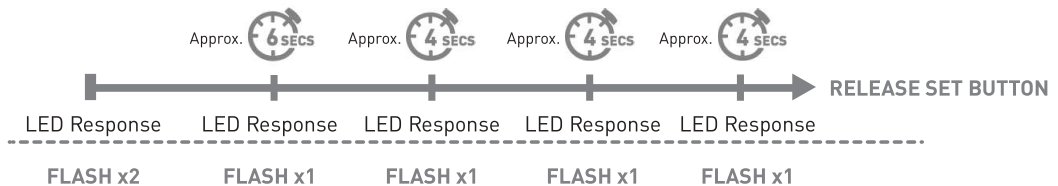

5 ADDING OR DELETING TRANSMITTER & CREATING GROUP CHANNELS



IMPORTANT

Multiple motors can be paired to the dry contact input transmitter for group control. Their limit settings and favorite positions should be individually adjusted by a single channel remote, which is only paired to one of those motors

- Confirm that motor limits and favorite position are already set for each individual motor.
- Ensure that each motor you want to group is also assigned to a channel by itself or another remote.

5.1 Using Motor P1 Button

NOTE: This is not applicable in mechanical switching mode.

Hold **P1** button on motor head.

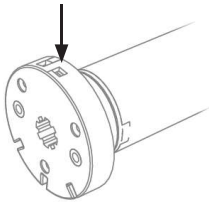

Motor Response



Hold **STOP** on controller to add or remove.

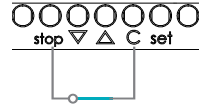

Motor Response

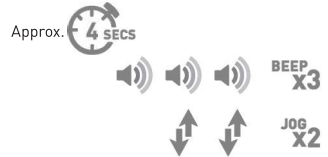

5.2 Using a preexisting Controller

Press **P2** on existing controller.



Pres **P2** on existing controller.



Press and release **SET** button on new transmitter.



Motor Response



Motor Response



Motor Response



6 SWITCH MODE OPERATION

Prior to selecting a switch mode, the upper and bottom limits of any ARC motors must be set. A single or combination of three dry contact inputs can operate the paired ARC motors.

6.1 Operation of Normal Switch Mode

NOTE: In this mode, the transmitter can implement all the ARC remote functions. The P2 button of the remote is described as the SET button in the transmitter. Please refer to the motor instructions for functions such as setting/adjusting limits, setting a favorite position, toggling tilt/roller mode etc.

MOVE UP UNDER ROLLER MOTOR MODE

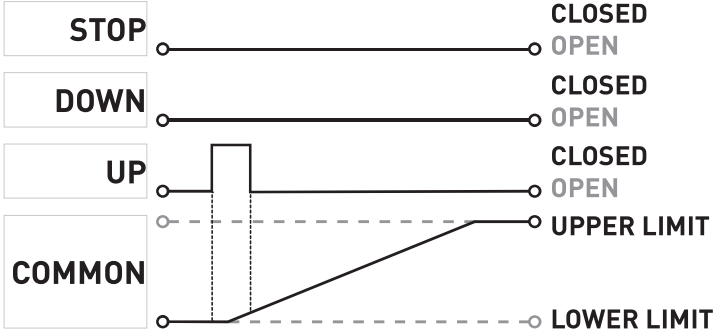

MOVE DOWN UNDER ROLLER MOTOR MODE

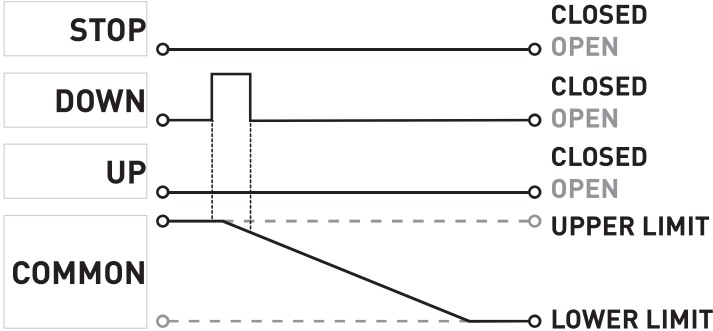

STOP UNDER ROLLER MOTOR MODE

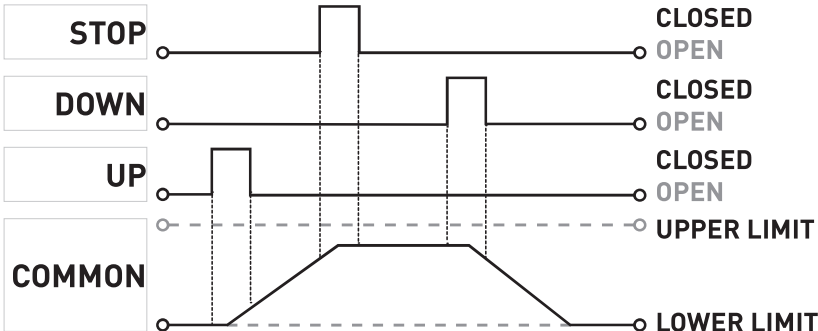

6.2 Operation of Pulse Switch Mode

NOTE: The time interval of each pulse should be in the range of 0.25 ~ 2.0 seconds. The motor rotation can be stopped by using the STOP button or the UP & DOWN together in the roller motor mode. In the tilt mode, each closing pulse triggers the motor to move one small step but a pulse longer than 2 seconds can trigger continuous movement of the motor.

MOVE UP/DOWN, STOP IN ROLLER MOTOR MODE

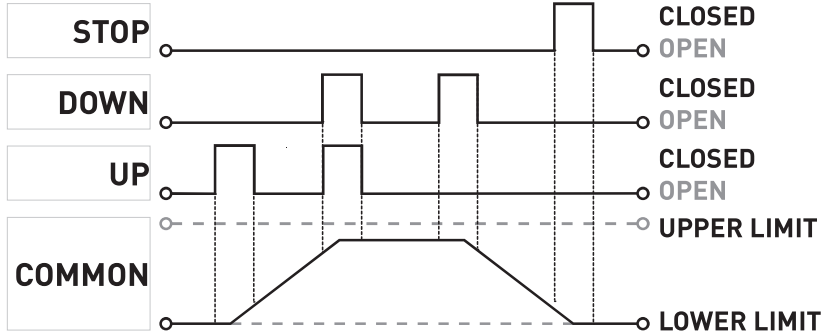

MOVE UP IN TILT MOTOR MODE

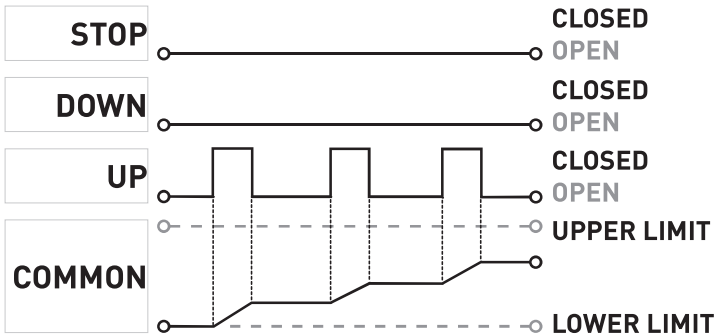

MOVE DOWN IN TILT MOTOR MODE

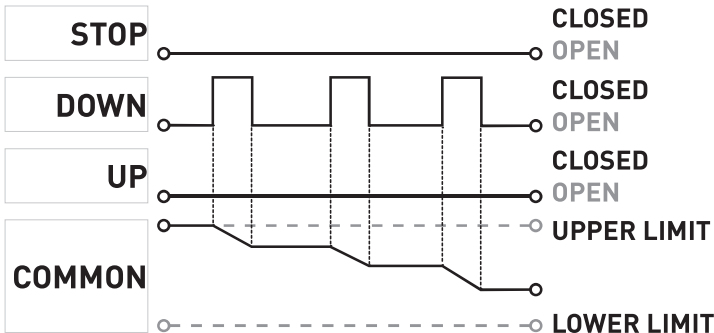

6.3 Operation of Mechanical Switch Mode

NOTE: Closing the UP/DOWN dry contacts keeps the motor rotating, opening the dry contacts immediately stops the rotation in the roller motor mode. In the tilt motor mode, each UP/DOWN closing pulse, whatever the pulse duration, triggers the motor to move one UP/DOWN step.

MOVE UP IN THE ROLLER MOTOR MODE

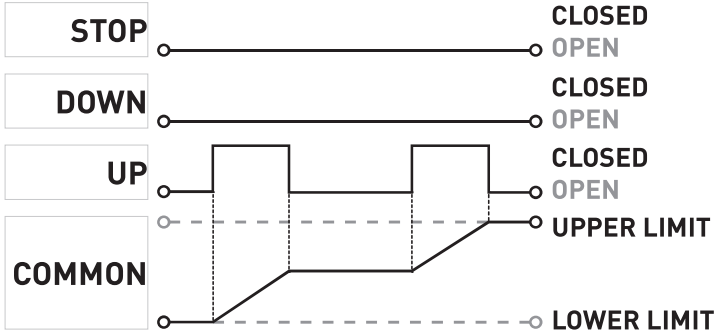

MOVE DOWN IN THE ROLLER MOTOR MODE

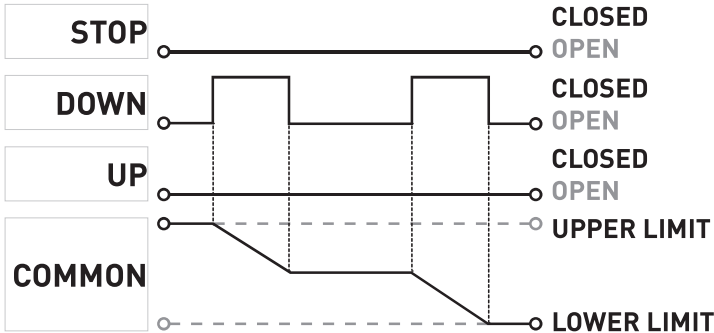

OPERATION IN TILT MOTOR MODE

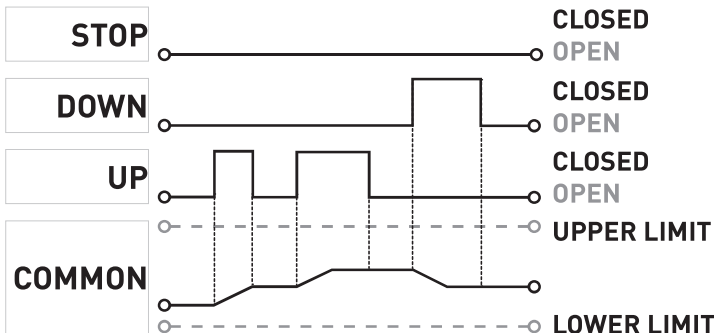

6.4 Operation of Sequence Switch Mode

NOTE: The closing/releasing of the “UP” pin alternatively triggers the upward movement or the stopping of the paired motor. The closing of the “DOWN” pin alternatively triggers the downward movement or the stopping of the paired motor.

MOVE UP IN THE ROLLER MOTOR MODE

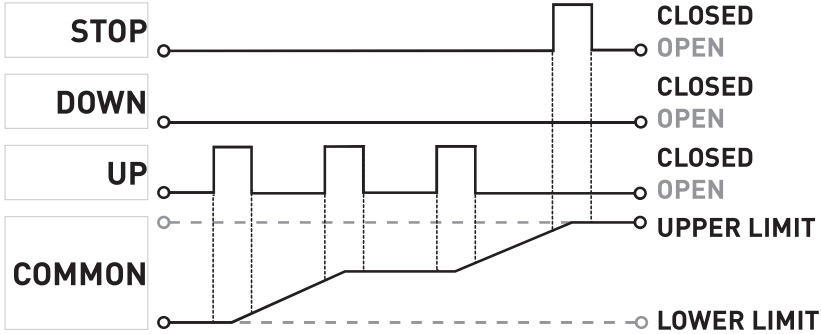

MOVE DOWN IN THE ROLLER MOTOR MODE

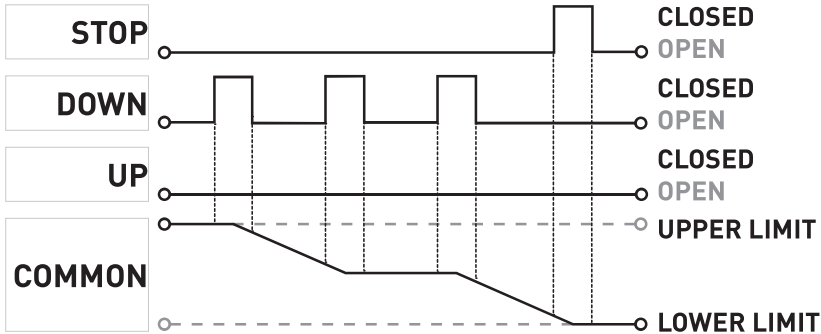

6.5 Operation of Favorite Position

NOTE: Closing the STOP pin for more than 5 seconds can activate the motor to move to the preset favorite position under Normal, Pulse & Sequence Mode.

FAVORITE POSITION

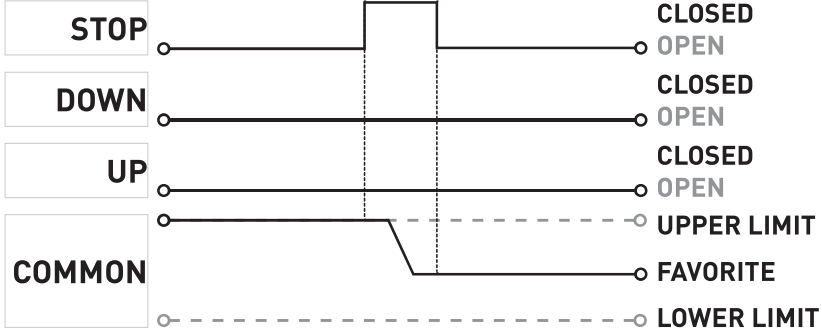

7 TROUBLE SHOOTING

Problem	Cause	Remedy
Motor is not responding	Switch power supply is not connected	Check power source and connections.
	Radio interference / Shielding	Ensure switch is positioned away from metal objects and that the antenna on motors are kept straight and away from metal.
	Receiver distance is too far from switch	Move switch to a closer position.
	Power failure	Check power supply to motor is connected and active (non-battery motors).
	Incorrect motor wiring	Check motor wiring is connected correctly (refer to motor installation instructions).
Cannot set limits on a single motor (multiple motors respond)	Transmitter has group control function set and drives all the paired motors together	Use an ARC remote to individually adjust motor limits.
		Use P1 motor button to set other motors in group into "Sleep" mode.
		SYSTEM BEST PRACTICE - Provide an extra 15 channel switch or remote in you multi motor projects to provide individual control for each motor for programming/ configuration purposes.
Motor will not go down after setting the top limit	Top limit was set using the down and stop buttons	Reset the motor and begin programming sequence again. Remember that upper limit is to be set using the up and stop and the down limit is set using the down and stop.