

# 15-20 F150

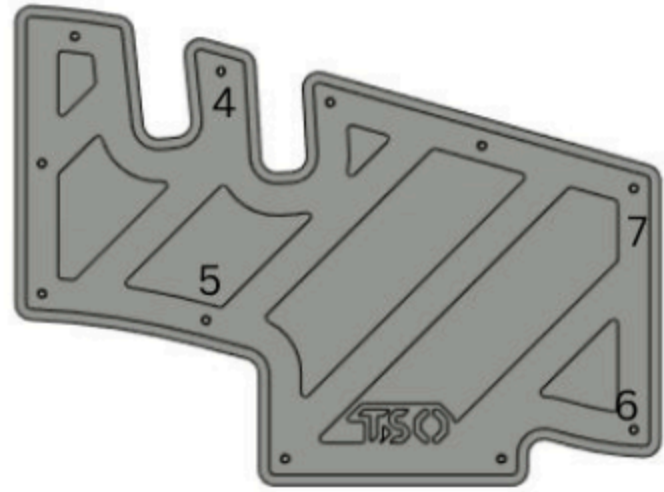

Locations 1-7 require a #29 drill bit and an 8-32 tap.  
Drill and tap these locations to accept the included hardware.

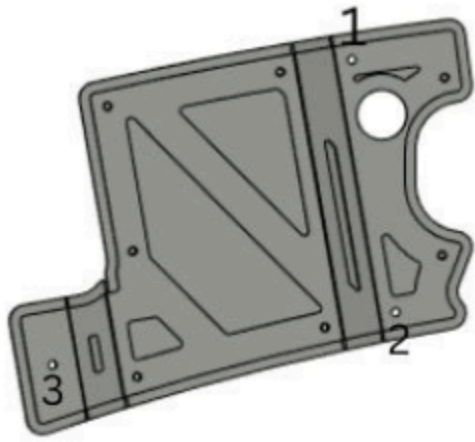
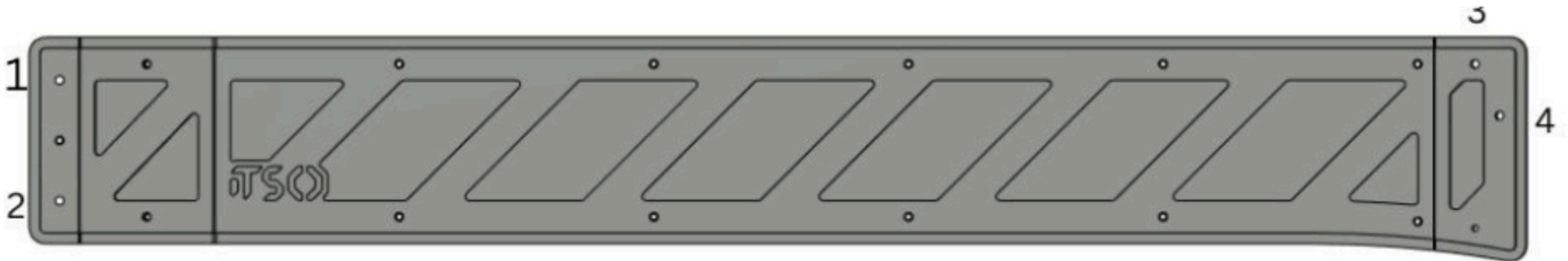

Locations 1-4 require a #29 drill bit and an 8-32 tap.  
Drill and tap these locations to accept the included hardware.

For locations 1-7 use a #29 drill bit and 8-32 tap to accept the included hardware

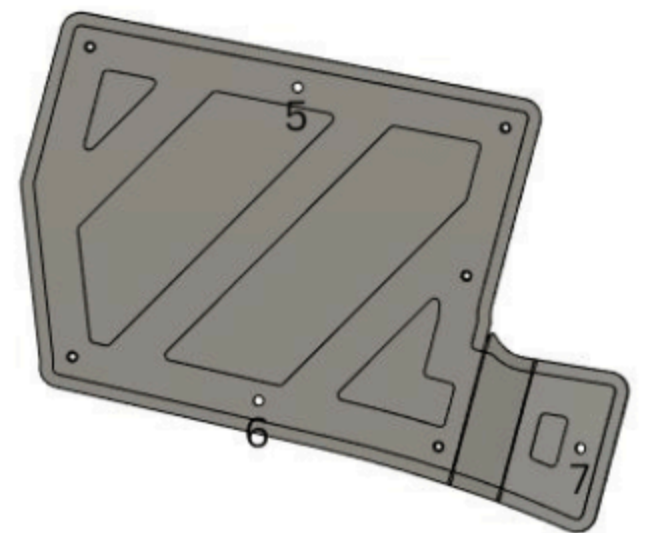
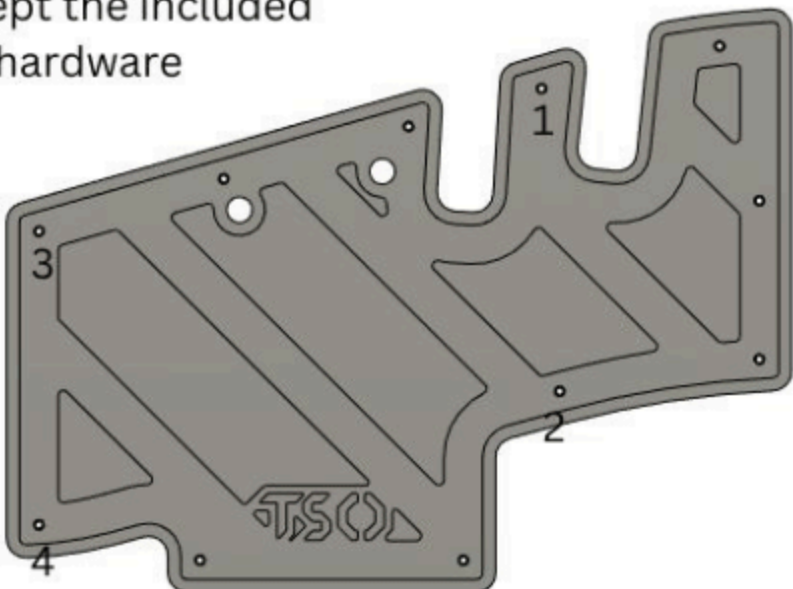

Locations 5-6 require included spacers