

ZUMIMALL[®]

Get Smarter about Your Security

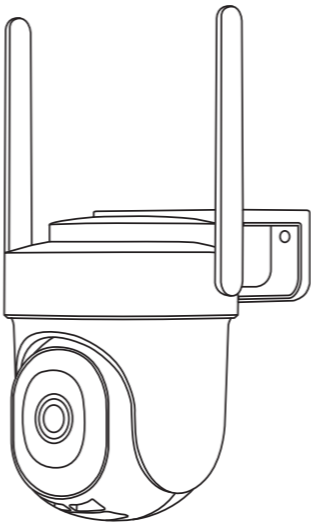

BF-BK05

FCC ID: 2AVKP-BF-BK04

PTZ Security Camera
QUICK START GUIDE

Welcome

Thank you for choosing ZUMIMALL. Please read this quick start guide carefully before using this product, for further information please scan the QR code below to download user manual on ZUMIMALL website.

Please scan the QR code to
get the detailed electronic manual.



English



German



French



Italian



Spanish



Japanese



Scan "zumimall" QR code to purchase products



Follow @zumimalloffice on Facebook

 @zumimall

 @zumimallcam

 @zumimalloffice

 @zumimallcamera

More About Us

Web: www.zumimall.com

Facebook: www.facebook.com/zumimalloffice

Amazon Store: www.amazon.com/zumimall

Product Service

Email: support@zumimall.com

Distributor: distributor@zumimall.com

Brand Story

ZUMIMALL, founded in 2008, focuses on the design and research of intelligent security technology. We insist on taking consumers as the core and strive to create smart home products that lead the global home fashion trend for consumers. Believe in craftsmanship to create top-quality goods, technology changes life. With high-quality products and first-class services, it has won the love and trust of millions of customers as soon as it went public.

Over the years, ZUMIMALL has served 45 continents, covering 80% of the population. We are the provider of smart lifestyles and a guardian of the wonderful moments of your life.

1 YEAR warranty

One-on-One Customer Service

How to Activate the Free 1-year Warranty Extension?

- ▶ Send us order number and SN number via email. ◀
- ▶ Please email us within 30 days of receiving the camera. ◀

Email: support@zumimall.com

1. What's in the Box

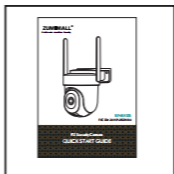
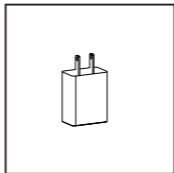
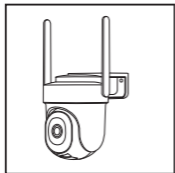

Camera * 1

Quick User Guide *1

Screws Set *1

Power Adapter *1

Charging Cable *1

2. Product Diagram

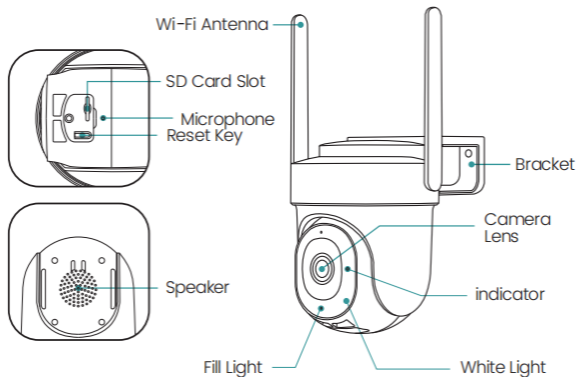

Reset Button	Keep pressing for 5-10 seconds to reset
Blink Slowly in Red	Awaiting Wi-Fi connection, ready add devices
Blink Fast in Red	Wi-Fi connecting
Solid in Red	Network problem
Solid in Blue	Wi-Fi connected, camera running normally
Blink Slowly in Blue	Firmware update

3. Download and Install App

Download ZUMIMALL App from Google Play™ or App Store™. Or scan the QR codes as below, with your smart phone.

NOTE: Google Play™ is a trademark of Google Inc. App Store™ is a service mark of Apple Inc.



NOTE: Please turn on both of the following permissions.

- ① Allow ZUMIMALL App to access mobile cellular data and wireless LAN, otherwise it will fail to connect the camera.
- ② Allow ZUMIMALL App to receive pushed messages, otherwise, the phone will not receive alarms when motion is detected.

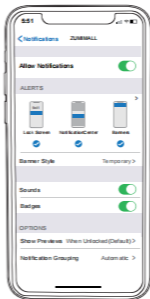
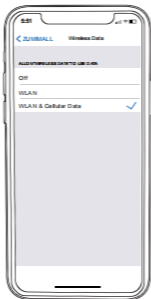

4. Account Registration

New user needs to sign up ZUMIMALL App with email address. Click 'Sign up' to create a New Account and follow the steps to complete registration.

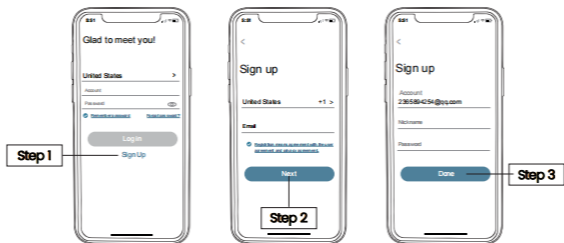

5. Add Camera to App

5.1 Preparations for connection

- ① Insert a Micro SD Card into the camera to save video clips or you can start the 7-day free cloud service. Without Micro SD Card or cloud service, no video will be saved.
- ② Please select 2.4G/5GWiFi to ensure good signal
- ③ When connecting to the network, please take the camera close to the router
(Recommended within 10-15ft).

5.2 Connect Camera to App



Tap 'Add Device'



Select 'Power Plug Camera'

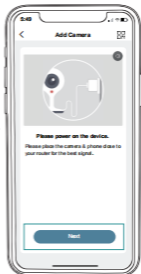

Turn on the Camera



Reset the Camera



Input Wi-Fi Password



Prepare the Scanning



Scan QR Code when Indicator
Flashing Slowly in Red



Finished Installation
When Reaches 100%



Perform Network Diagnosis

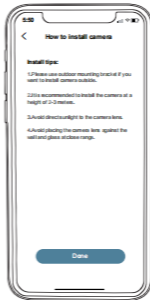

View Installation Tips

1. Was ist in der Box

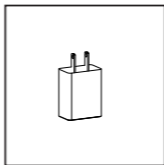
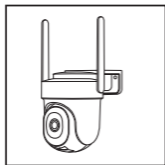

Kamera *1

Kurzbedienungsanleitung *1

Schrauben Satz *1

Netzadapter *1

Aufladen-Kabel *1

2. Produkt-Diagramm

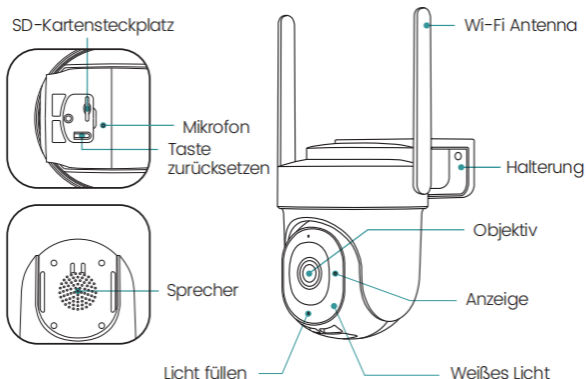

Reset-Taste	Zum Zurücksetzen 5-10 Sekunden lang gedrückt halten
Blinkt langsam in Rot	Bereit zum Hinzufügen von Geräten
Blinkt schnell in Rot	Wi-Fi-Verbindung
Solide in Rot	Netzwerk-Problem
Solide in Blau	Wi-Fi verbunden, Kamera läuft normal
Blinkt langsam in Blau	Aktualisierung der Firmware

3. App herunterladen und installieren

Laden Sie die ZUMIMALL App von Google Play™ oder App Store™ herunter. Oder scannen Sie die QR-Codes wie unten mit Ihrem Smartphone.

HINWEIS: Google Play™ ist eine Marke von Google Inc.

App Store™ ist eine Dienstleistungsmarke von Apple Inc.



HINWEIS: Bitte schalten Sie die folgenden beiden Berechtigungen ein.

- ① Erlauben Sie der ZUMIMALL App den Zugriff auf mobile Daten und Wireless LAN, das sie sonst sonst kann sie die Kamera nicht verbinden.
- ② Erlauben Sie der ZUMIMALL App, Push-Nachrichten zu empfangen, sonst wird das Telefon keine Alarme empfangen, wenn eine Bewegung erkannt wird.

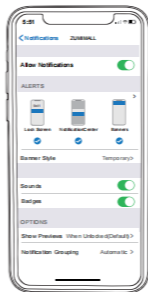
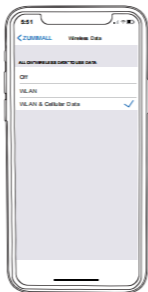

4. Registrierung eines Kontos

Neue Benutzer müssen die ZUMIMALL App mit ihrer E-Mail-Adresse registrieren. Klicken Sie auf 'Anmelden', um ein neues Konto zu erstellen und folgen Sie den Schritten, um die Registrierung abzuschließen.

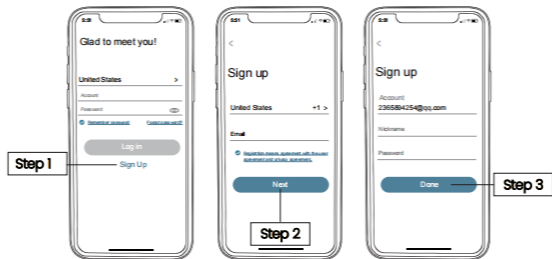

5. Kamera zur App hinzufügen

5.1 Vorbereitungen für den Anschluss

- ① Legen Sie eine Micro SD-Karte in die Kamera ein, um Videoclips zu speichern, oder nutzen Sie den 7-Tage-Cloud-Service kostenlos nutzen. Ohne Micro-SD-Karte oder Cloud-Service wird kein Video gespeichert werden.
- ② Bitte wählen sie 2.4G/5GWifi, um das signal zu gewährleisten
- ③ Wenn Sie eine Verbindung zum Netzwerk herstellen, bringen Sie die Kamera bitte in die Nähe des Routers.
(Empfohlen innerhalb von 10-15ft).

5.2 Kamera mit App verbinden



Tippen Sie auf 'Gerät hinzufügen'



Wählen Sie Netzstecker Kamera

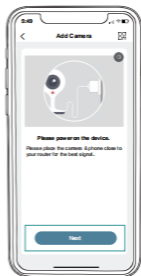

Schalten Sie die Kamera ein

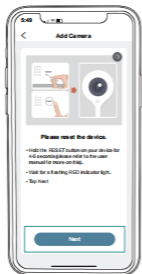

Zurücksetzen der Kamera



Wi-Fi-Passwort eingeben



Vorbereiten des Scanners



QR-Code scannen, wenn die Anzeige Langsam rot blinkt



Abgeschlossene Installation
Wenn 100% erreicht sind



Netzwerkdiagnose durchführen

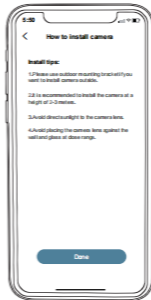

Installationstipps anzeigen

1. 箱の中身

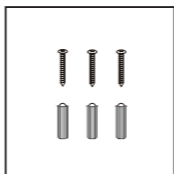
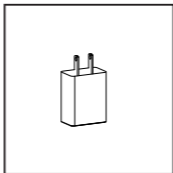
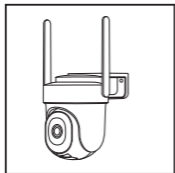

カメラ *1

クイック・ユーザー・ガイド *1

ネジセット *1

電源アダプター *1

充電用ケーブル *1

2. 製品ダイアグラム

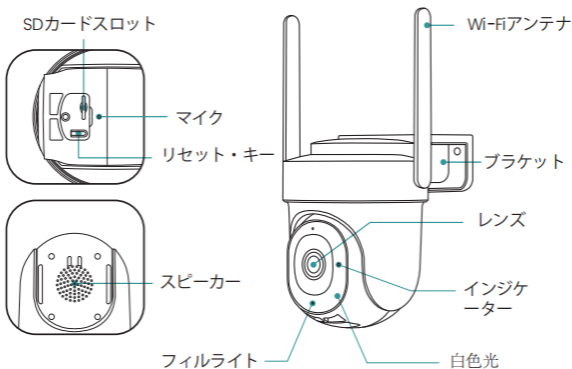

電源ボタン	5～10秒間押し続けて電源オン/オフ
リセットボタン	5～10秒間押し続けてリセットする
赤でゆっくりと点滅	Wi-Fi接続待ち、デバイス追加準備完了
赤で高速点滅	Wi-Fi接続
ソリッド・イン・レッド	ネットワーク問題
ソリッド・イン・ブルー 青でゆっくりと点滅	Wi-Fi接続、カメラは正常に動作 ファームウェア・アップデート

3. アプリのダウンロードとインストール

Google Play™またはApp Store™からZUMIMALLアプリをダウンロードしてください。

または、下記のQRコードをスマートフォンで読み取ってください。

注: Google Play™はGoogle Inc.の商標です。

App Store™は、Apple Inc.のサービスマークです。



注: 以下の両方の権限をオンにしてください。

① ZUMIMALLアプリが携帯電話データおよび無線LANにアクセスできるようにします。カメラの接続に失敗します。

② ZUMIMALLアプリがプッシュされたメッセージを受信できるようにします。アラームを受信しません。

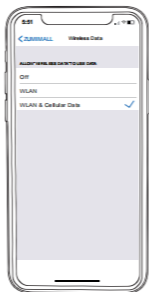

4. アカウント登録

ZUMIMALLアプリに新規登録するにはメールアドレスが必要です。新規登録をクリックして 新規アカウントを作成し、手順に従って登録を完了してください。

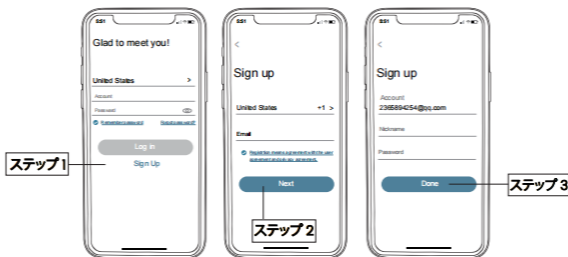

5. アプリにカメラを追加する

5.1 接続の準備

- ① マイクロSDカードをカメラに挿入してビデオクリップを保存するか、7日間無料のクラウドサービスを開始できます。クラウドサービスを開始することもできます。マイクロSDカードまたはクラウドサービスがない場合、ビデオは保存されません。保存されません。
- ② 2G/5GWiFiを選択して、良好な信号を確保します。
- ③ ネットワークに接続する際は、カメラをルーターに近づけてください。(10～15フィート以内を推奨)。

5.2 カメラとアプリの接続



デバイスの追加」をタップする



電源プラグカメラ」を選択

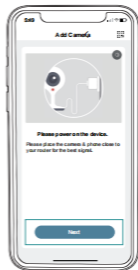

カメラの電源を入れる



カメラのリセット



Wi-Fiパスワードの入力



スキャンの準備



インジケーターが
赤でゆっくり点滅



インストール完了
100%達成時



ネットワーク診断の実行

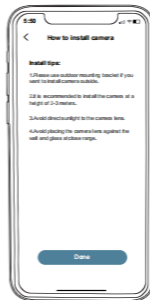

インストールのヒントを見る

ZUMIMALL[®]

Get Smarter about Your Security

FCC ID: 2AVKP-BF-BK04



® 210-221219 Made in China