



# MOBILITY SCOOTER

EW-M41 Instruction Booklet



# TABLE OF CONTENTS

|   |    |
|---|----|
| INTRODUCTION .....  | 1  |
| IMPORTANT PRECAUTIONS .....                                       | 2  |
| SAFETY INFORMATION ON ELECTROMAGNETIC<br>INTERFERENCE (EMI) ..... | 3  |
| SAFETY WARNING & INSTRUCTION LABELS .....                         | 5  |
| IDENTIFICATION OF PARTS .....                                     | 6  |
| OPERATING YOUR SCOOTER .....                                      | 7  |
| CHARGING THE BATTERIES .....                                      | 9  |
| DISASSEMBLING YOUR SCOOTER .....                                  | 10 |
| CARE AND MAINTENANCE .....  | 12 |
| TROUBLE SHOOTING .....  | 13 |
| CAUTION .....   | 14 |
| SPECIFICATION .....   | 15 |

## INTRODUCTION

**Thank you and congratulations on purchasing your new Ewheels Medical Mobility Scooter. It is designed to provide you with transportation ability indoors and outdoors.**

We pride ourselves on providing safe and comfortable products. Our goal is to ensure your complete satisfaction. We sincerely hope you enjoy your Ewheels Medical Mobility Scooter.

Please read and observe all warnings and instructions provided in the owner's manual before you operate any function of this scooter. Also, please retain this manual for future reference.

**If you have any question, you can contact :**

### **Ewheels Medical**

1000 W. Vista Bonita  
Drive Suite B101  
Phoenix, Arizona  
85027, U.S.A

**or your local dealer:**

### **CAUTION :**

**Federal law restricts this device to sale by or on the order of a physician or other certified personnel licensed by the law of the state (US only) or region in which this personnel practices to use or order the use of this device.**

## IMPORTANT PRECAUTIONS

- Only one person at a time could ride a Ewheels Medical Mobility Scooter.
- Maximum load 350 lbs pounds.
- Turn the key off before getting on or off.
- Always drive carefully and be aware of others using the same area.
- If the mobility product is to be operated on public roads, the vehicle driver is responsible for ensuring that it is in an operationally reliable condition. Inadequate or neglected care and maintenance of the mobility product will result in a limitation of the manufacturer's liability.
- If at all possible, avoid driving on slippery surfaces (such as snow, gravel, ice, etc.) Where there is a danger of you losing control over the vehicle, especially on a gradient!
- Never attempt to ascend or descend a slope on slippery surfaces or where there is a danger of skidding.
- Always use pedestrian crossings wherever possible. Take extreme care when crossing roads.
- Do not drive on slopes exceeding 8 degree, and take extreme care when turning on a slope.
- Do not use full power when turning a sharp corner.
- Take great care and drive at low speed when backing up, riding downhill or on uneven surfaces, and climbing curbs.
- Use the lowest speed when driving on descending road or uneven terrain.  
If speed is too fast, leave your hand off the handle bar, let the scooter come to a stop. Ensure it is safe to start again.
- The weight capacity limit will vary at ramp degree (please refer to following picture).

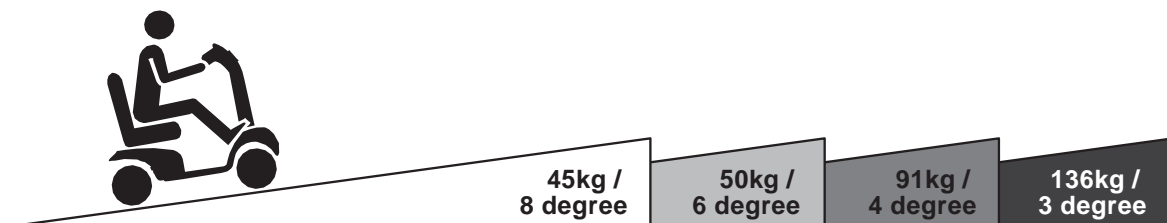

- The grade climbing degree will be affected by weight capacity, driving speed, ramp degree, and scooter parameter.
- To prevent any danger from motor defected; please avoid to drive on long ramp or any uneven terrain.
- To prevent damage to the motor, avoid driving on long 8 degree ramps or uneven terrain.

- A slow speed must always be used when ascending, descending or traversing aslope or incline and also on uneven terrain, ramps and soft or loose surfaces, such as gravel or grass.
- To prevent any danger, do not turn at high speed on ascending, descending ramp.
- Scooter may not operate well in high humidity.
- Avoid using the scooter during poor weather conditions, such as rain or snow.
- Direct exposure to rain or humid conditions will cause the scooter to malfunction electrically and mechanically; This will also cause the scooter to prematurely rust.
- Never leave the scooter in neutral when parked on slopes.
- Follow all relevant traffic laws when riding outside.
- When the scooter is being transported, do not sit or stay on scooter.

- Any unauthorized modification is prohibited. Please do not attempt to modify the scooter yourself.
- Never use the scooter while under the influence of fireworks. Keep away from flammable objects while charging as it may lead to fire or explosion of battery or oxygen tank.
- Do not smoke while charging as the battery may release hydrogen gas. Please charge your battery in a well-ventilated space.

## **SAFETY INFORMATION ON ELECTROMAGNETIC**

**CAUTION : It is very important that you read this information regarding the possible effects of Electromagnetic Interference on your motorized scooter.**

Powered wheelchairs and motorized scooters may be susceptible to electromagnetic interference (EMI), which is interfering electromagnetic energy (EM) emitted from sources such as radio stations, TV stations, amateur radio (HAM) transmitters, two-way radios, and mobile phones. The interference (from radio wave sources) can cause the motorized scooter to release its brakes, move by itself, or move in unintended directions. It can also permanently damage the motorized scooter control system. The intensity of the interfering EM energy can be measured in volts per meter (V/m). Each motorized scooter can resist EMI up to certain intensity. This is called its "immunity level." The higher the immunity level, the greater the protection. At this time, current technology is capable of achieving at least a 20 V/m immunity level, which would provide useful protection from the more common sources of radiated EMI. This immunity level of this motorized scooter model is 20 V/m.

There are a number of sources of relatively intense electromagnetic fields in the everyday environment. Some of these sources are obvious and easy to avoid. Others are not apparent and exposure is unavoidable. However, we believe that by following the warnings listed below, your risk to EMI will be minimized.

### **The sources of radiated EMI can be broadly classified into three types :**

1. Hand-held portable transceivers (transmitters-receivers) with the antenna mounted directly on the transmitting unit. Examples include: citizens band (CB) radios, "walkie talkie," security, fire, and police transceivers, mobile telephones, and other personal communication devices;

**WARNING : Some mobile telephones and similar devices transmit signals while they are ON, even when not being used.**

2. Medium-range mobile transceivers, such as those used in police cars, fire trucks, ambulances, and taxis. These usually have the antenna mounted on the outside of the vehicle; and

3. Long-range transmitters and transceivers such as commercial broadcast transmitters (radio and TV broadcast antenna towers) and amateur (HAM) radios.

**WARNING : Other types of hand-held devices, such as cordless phones, laptop computers, AM/FM radios, TV sets, CD players, and cassette players, and small appliances, such as electric shavers and hair dryers, so far as we know, are not likely to cause EMI problems to your motorized scooter.**

**Motorised Scooter Electromagnetic Interference :**

Because EM energy rapidly becomes more intense as one moves closer to the transmitting antenna (source), the EM fields from hand-held radio wave sources (transceivers) are of special concern. It is possible to unintentionally bring high levels of EM energy very close to the motorized scooter control system while using these devices. This can affect motorized scooter movement and braking. Therefore, the warnings listed below are recommended to prevent possible interference with the control system of the motorized scooter.

**Warnings :**

Electromagnetic interference (EMI) from sources such as radio and TV stations, amateur radio (HAM) transmitters, two-way radios, and mobile phones can affect motorized scooters. Following the warnings listed below should reduce the chance of unintended brake release or motorized scooter movement which could result in serious injury.

1. Do not operate hand-held transceivers (transmitters-receivers), such as citizens band (CB) radios, or turn ON personal communication devices, such as mobile phones, while the motorized scooter is turned ON;
2. Be aware of nearby transmitters, such as radio or TV stations, being to them;
3. If unintended movement or brake release occurs, turn the motorized scooter OFF as soon as it is safe;
4. Be aware that adding accessories components, or modifying the motorized scooter, may make it more susceptible to EMI; and

**WARNING : There is no easy way to evaluate their effect on the overall immunity of the motorized scooter.**

5. Report all incidents of unintended movement or brake release to the distributor listed on the inside front cover of this manual. Note whether there is a source of EMI nearby.

**Important Information :**

1. 20 volts per meter (V/m) is a generally achievable and useful immunity level against EMI (as of May 1994). The higher the level, the greater the protection.
2. The immunity level of this product is 20 V/m.

**SAFETY WARNING & INSTRUCTION**



|          |   |          |  |
|----------|---|----------|--|
| <p>1</p> | <p><b>Warning Sticker</b></p> <ol style="list-style-type: none"> <li>1. Please read the instruction booklet carefully before using your scooter.</li> <li>2. Do not drive the scooter on slippery surfaces or on slopes over 8 degrees limit.</li> <li>3. Do not drive on highway, crowded roads, or unfamiliar areas.</li> <li>4. Do not turn at high speed in either forward or reverse.</li> <li>5. Do not wash with water or leave scooter in humid environment since water can damage the electronic parts.</li> </ol> |          |  |
| <p>2</p> | <p>Power warning label</p>  | <p>7</p> | <p>Information Sticker states the date of manufacture and serial number of the scooter.</p> <p>This product has been supplied from an environmentally aware manufacturer.</p> <p>It may contain substances that could be harmful to the environment.</p> <p>Recycling must be carried out in accordance with the respective national legal provisions.</p> |
| <p>3</p> | <p>Instruction of battery lock nut label</p>  | <p>8</p> | <p>EU representative label (*For European area use ONLY)</p>   |
| <p>4</p> | <p>Wiring diagram Label</p>   | <p>9</p> | <p>N-D Lever Adjustment label which instructs freewheel mode operation.</p>  |



# IDENTIFICATION OF PARTS

Before attempting to drive this scooter on your own, it is important that you familiarize yourself with the controls, and how to operate them safely.

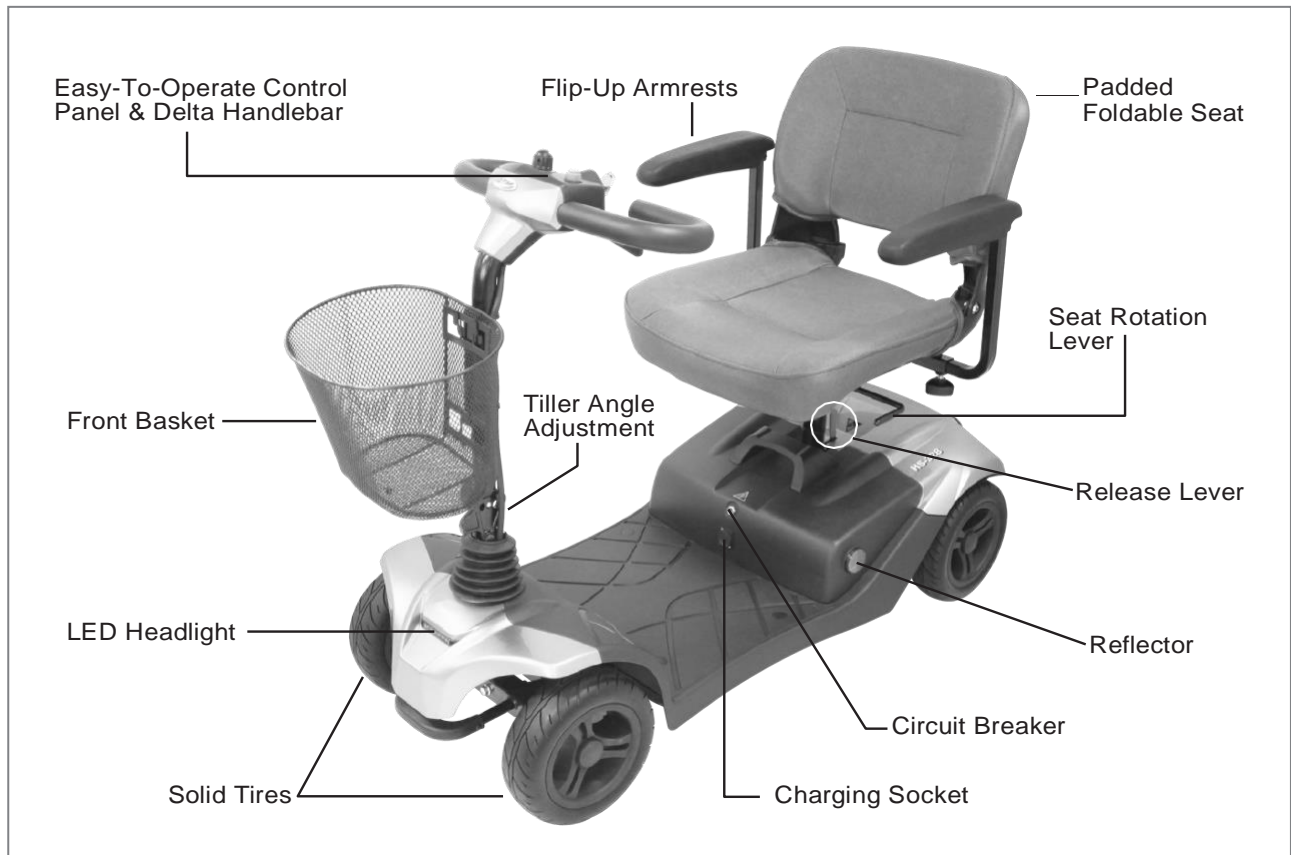

**Figure 1 - EW-M41 Front View**

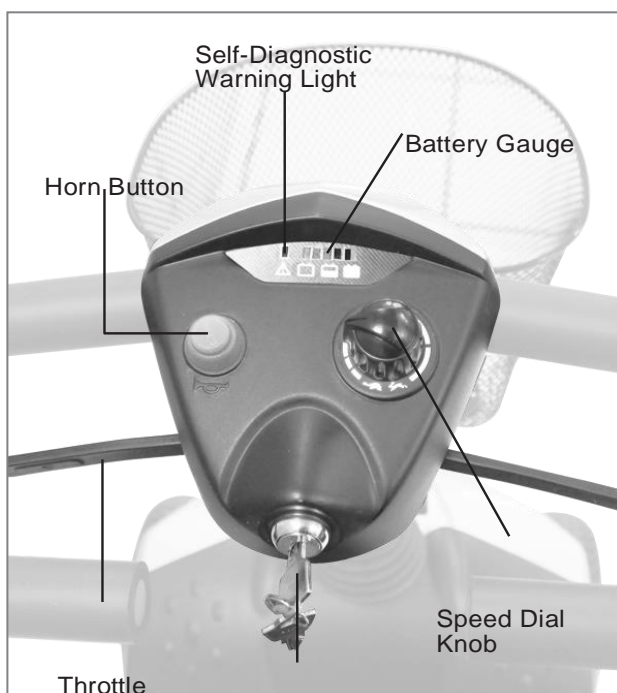

**Figure 2 - EW-M41 Top Control Panel**



**Figure 3 - EW-M41**

**Back View**

## OPERATING YOUR SCOOTER

Before operation, please remove the Lock Nut (A) and press button of Circuit Breaker (B) to activate the system.

### FUNCTION OF PARTS :

#### Main Key Switch (C)

1. Turn the key to the right  
Turn the scooter on.
2. Turn the key to the left and LED head light on.
3. Turn the key to the center position  
Turn the scooter off.

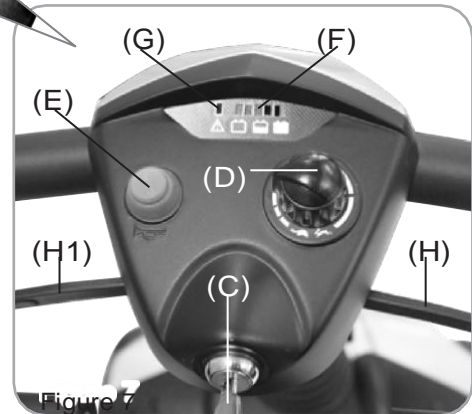
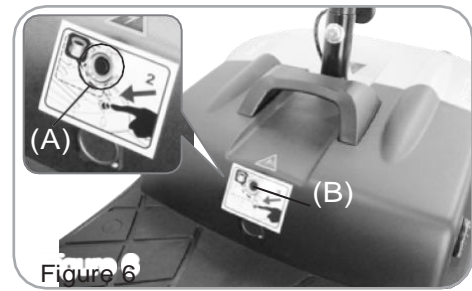
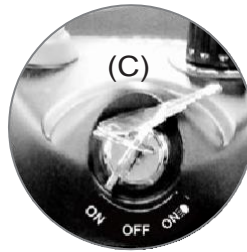

**WARNING :** Always ensure that the scooter is switched OFF before getting on or off the scooter and before removing any items from the scooter.

**WARNING :** Turning the scooter OFF whilst driving will bring the scooter to an abrupt stop

#### Speed Dial Knob (D)

The rabbit icon indicates fast or high speed. The turtle icon indicates slow or low speed. By turning this Knob (D) towards chosen the icon, you can control the overall speed of the scooter.

**WARNING :** Before driving the scooter, set the speed to low speed by turning the knob towards turtle icon.

**WARNING :** Drive in high speed when encounter an up slope, and drive in low speed when encounter a down slope.

#### Horn Button (E)

Press The Horn Button (E) once to sound a warning tone when necessary.

#### Battery Gauge (F)

The LEDs represents an approximation of battery capacity. If the charge is full, all LEDs are lit. When only red and orange LEDs are lit, the batteries are almost consumed and should be charged. When only red LEDs are lit, charge the batteries immediately.

#### Self Diagnostic Warning Light (G)

Flashing lights indicate there is a problem within scooter. See page 11 for more information.

#### Throttle (H) (H1)

To move forward, pull the right side of Throttle (H). To move backward, pull the left side of Throttle (H1). (The movement directions can be reversed by local dealers if required.) Releasing the throttle to engage automatic brake. These are also your accelerators, the further you pull it, the faster you go. (Subject to the position of the Rabbit/Turtle control).

**WARNING :** Releasing the throttle engages the automatic brake, However the scooter will taxi for a short buffering distance, please keep safe distance when stopping to prevent any collisions.

**Tiller Angle Adjustment :**

1. Turn the Cap (I) (outward upward) to disengage the pin.
2. Simultaneously, adjust the tiller fore-and-aft to the most comfortable angle. Release Cap (I) and ensure the pin is fully engaged to lock the tiller in position.

**Seat Rotation Adjustment :**

1. Lift the Lever (J) upward to disengage the pin.
2. Simultaneously, rotate the seat (K) to the most comfortable angle.  
To lock the seat in position, Release the lever (J) and ensure the pin is fully engaged.

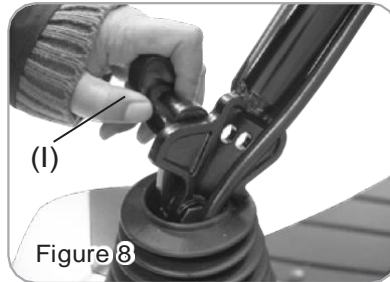
**Circuit Breaker :**

If scooter's circuit system malfunctions or is over loaded, the circuit breaker will trip and automatically shut down the power to ensure driver's safety. After shut down, press button of Circuit Breaker (B) to reactive the circuit system.

**Free-Wheeling Lever :**

If required the scooter can be pushed when the Free-Wheeling Lever (L) is disengaged. To engage the Free-Wheeling Lever (L), Pull up the free-wheeling lever. To disengage the Free-Wheeling Lever (L), Push down the free-wheeling lever.

NOTE: Ensure scooter is switched OFF!

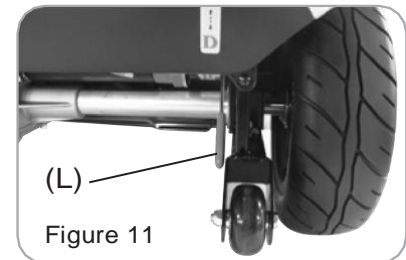
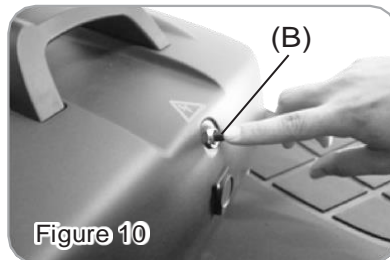
**Basket assembling and disassembling :**

1. Place the Front Basket (M) to the bracket on the tiller.
2. Remove the Front Basket (M) and place it aside.
3. Weight : 3kg

**Armrest assembling and angle adjustment :**

1. Adjust armrest to most comfortable length, then lock the Knob (N).
2. Adjust Screw (O) height to preferable armrest's angle

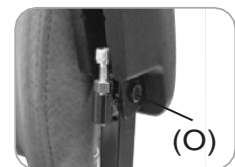
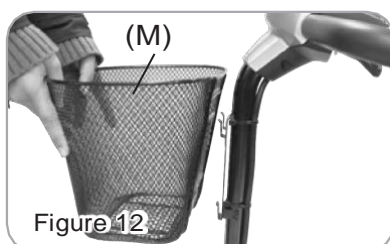

**Seat Height adjustment :**

1. Remove the seat, then screw, nut and washer from seat post.
2. Adjust seat post to desired height, then attached tightly with screw, nut and washers.
3. Assemble the seat back to its original position.
4. Seat height adjustability  
520mm / 545mm / 570mm.

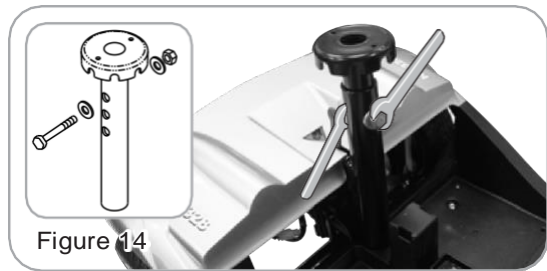

Figure 14

**CHARGING THE BATTERIES**

Your Ewheels Medical scooter is equipped with two sealed, maintenance free 12V. 22ah lead acid. rechargeable batteries and one HS-328 24V/5A charger. Batteries must be charged before using the scooter for first time and should be recharged after each day's use. Ensure the power switch is in the OFF position and free-wheeling lever is not in freewheel mode. For safety reasons, only sealed non-spillable batteries that meet DOT CFR 173.159(d), IATA Packing Instructions, and IATA Provision A67 shall be installed in the scooters. If new batteries are required, contact your dealer.

1. Insert battery charger cord into Charging Socket (P) on battery pack.
2. Plug other end of Power Cable (Q) into a standard electrical wall outlet.
3. LED Indication  
LED (Power) - RED Light on : Power on  
LED (Charge) - ORANGE Light on : Charging  
GREEN Light on : Fully charged
4. Allow batteries to charge until charging indicator turns green.
5. After indicator turns green, unplug battery charger from scooter and wall outlet.
6. Do not charge simultaneously with battery box socket and optional charging socket, as this will cause serious risk free or electrocution.
7. If at any time the battery charger light flashes green over 40 minutes, this indicates abnormal charging occurred.  
You should check the following :
  - Charger plug is correctly positioned
  - Scooter is turned off
  - If none of these are the problems, contact your local authorised dealer.

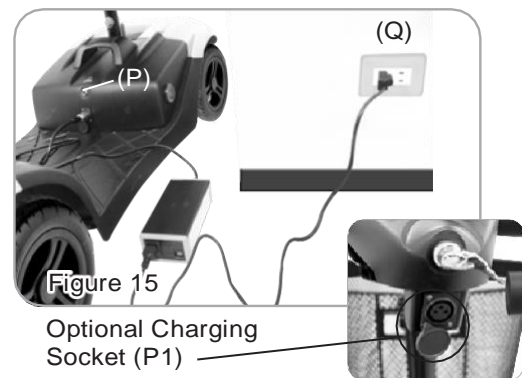

Figure 15

Optional Charging Socket (P1)

**WARNING :** The time needed to recharge will vary depending on the depletion of the batteries. Charging for longer than necessary will not harm the batteries. They can not be overcharged.

**Battery shelf life :**

- Standby use battery life :  
3 ~ 5 years under 2.3Vpc and 20°C floating charge condition.
- Cycle use battery life :  
200 cycles (100%DOD)  
225 cycles ( 80%DOD)  
500 cycles ( 50%DOD)

Batteries will lose capacity due to self-discharge through packing, transportation and storage process at various temperatures. The relation between battery capacity and storage temperature and time is as follows :

| Storage temperature | 1 month | 3 month | 6 month | 12 month    |
|---------------------|---------|---------|---------|-------------|
| 0°C~ 5°C            | 96%     | 93%     | 90%     | 80%         |
| 5°C~ 20°C           | 92%     | 90%     | 80%     | 65%         |
| 20°C~ 30°C          | 90%     | 80%     | 65%     | 50%         |
| 20°C~ 40°C          | 83%     | 70%     | 50%     | Not allowed |

**Keep in mind these rules :**

- Fully charge the batteries at least once a month, or more if you use scooter regularly. Charge after each trip exceeding 3 kilometers.
- If storing your scooter for some time (1 month or more), make sure that batteries are fully charged, and on returning, charge them again before using the scooter.
- Batteries will only give maximum performance after scooter has been used, and batteries have been recharged up to 10 times.

Please be aware that the travelling range of your mobility scooter is impacted by how fast the batteries are discharged. This will depend on many circumstances, such as ambient temperature, condition of the surface of the road, tire pressure, weight of the driver, driving environment (inclines etc.) and utilization of your lighting system if fitted. We recommend that you test your local ride with a family member to ensure a safe journey.

**DISASSEMBLING YOUR SCOOTER****I. Seat Disassembling :**

Remove seat by lifting Seat Rotation Lever (J). Then rotate Seat (K) and lift up away from scooter.

**II. Battery Pack Disassembling :**

As indication, pull Battery Pack Handle (R) to remove Battery Box (S) from scooter. Caution : Battery Box is heavy. When lifting, please use correct lifting posture to avoid injury. Ask for assistance if necessary.

**WARNING :** When assembling battery pack (S), make sure to aim for the battery terminal connection for proper electricity conductivity.

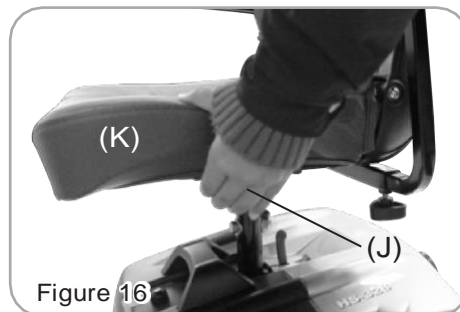

Figure 16



Figure 17

**III. Front & Rear Frame Disassembling :**

Hold front & rear frame with Release Lever (T) to disassemble front and rear frame.



Figure 18



Figure 19

**Tiller Fold Method :**

Turn the Cap (I) to fold down the Tiller (U) to the lowest position as shown in Figure 20. When the Tiller (U) is in the lowest position it can be locked by the pin of tiller angle adjustment.

**Completion of Disassembling:**

The Scooter can be disassembled into 7 main parts as shown in Figure 21.

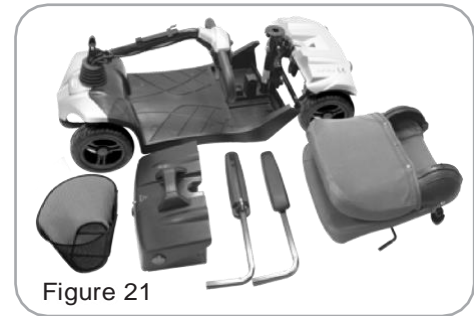
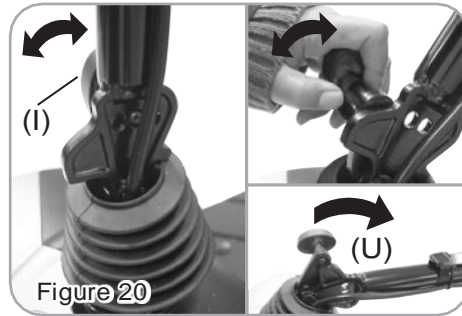

**WARNING : Re-assembling your scooter by vice versa above disassembling procedures.**

## CARE AND MAINTENANCE

### DAILY CHECK

Please always check your scooter before you start your every journey.

| Check point                                       | Inspection   | What to do if the inspection is failed  |
|---|--|---|
| N-D lever   | Check for correct function   | Contact your dealer.  |
| Horn  | Check for correct function   | Contact your dealer.  |
| Throttles   | Pull the wigwag to test the scooter movement   | Contact your dealer.  |
| Electro-mechanical brake and Emergency hand brake | Pull the wigwag a little bit and release it to test if brake works. If your scooter comes with emergency handbrake, please check it as well. | Contact your dealer.  |
| Battery Gauge                                     | Check if the battery gauge is displayed and whether it is at low power.  | <ul style="list-style-type: none"> <li>• Contact your dealer if battery gauge is not working.</li> <li>• Recharge the battery immediately if low</li> </ul> |
| Rear mirror (s)                                   | Check if the parts are clean and firmly tighten to the scooter and do not wobble.  | <ul style="list-style-type: none"> <li>• Clean up the dirt by damp cloth.</li> <li>• Tighten the screw or clamping stem that holds the mirror(s)</li> </ul> |
| Lighting  | Check if all lights, such as head lights, rear lights, and turn signal are functioning correctly.  | Contact your dealer.  |

### WEEKLY CHECK

| Check point     | Inspection   | What to do if the inspection is failed |
|-----------------|--|--|
| Speed Dial Knob | Check for correct function   | Contact your dealer.                   |
| Armrests        | Check if the parts are clean and firmly tighten to the scooter and do not wobble. Tighten the screw knob that holds the armrest.   | Contact your dealer.                   |
| Wheels/Tires    | Inflate the tire to the correct pressure and check that <ol style="list-style-type: none"> <li>1. Drive wheels rotate without wobbling.</li> <li>2. Tire tread depth is not less than 0.5mm.</li> <li>3. No foreign objects in tires.</li> </ol> | Contact your dealer.                   |
| Motor           | Check for correct function   | Contact your dealer.                   |
| Battery Charger | Check if the charger is functioning correctly and the batteries are charged.   | Contact your dealer.                   |

### MONTHLY CHECK

| Check point       | Inspection   | What to do if the inspection is failed |
|-------------------|--|--|
| Seat / Upholstery | Check for movement and if it's worn  | Contact your dealer.                   |
| Electronics       | Check if all the battery cables and connectors are firmly tighten to the scooter | Contact your dealer.                   |



## TROUBLE SHOOTING

Here are some suggestions about solving problems you may have with your scooter. There is a self-diagnostic warning light on the control panel. To check the self-diagnostic warning light, turn on the key and count the number of blinks on the warning light.

### SCOOTER WON'T MOVE WHEN KEY IS TURNED ON

| Check point   | Solution  |
|---|---|
| Check if the power is off   | Turn the power on.  |
| Check if the N-D lever is in Neutral position                         | Switch to D (drive) position. Turn off the power and turn on again. |
| Check if the battery power is enough.<br>(Battery gauge is under 25%) | Recharge the battery and then retest.                               |
| Check if the charger power cord is still plugged in scooter           | Unplug the charger power cord.                                      |

### ERROR CODE

| Flash | Description                                   | Initial check points  |
|-------|---|---|
| 1     | Battery Low                                   | The batteries are running low.<br>·Recharge the batteries.  |
| 2     | Low Battery Fault                             | The batteries have run out of charge.<br>·Recharge the batteries.<br>·Check the battery and associated connections and wiring.  |
| 3     | High Battery Fault                            | Battery voltage is too high. This may occur if overcharged and/or traveling down a long slope.<br>·If traveling down a slope, reduce your speed to minimize the amount of regenerative charging.  |
| 4     | Current limit time-out or controller overheat | The motor has been exceeding its maximum current rating for too long.<br>·The scooter may have stalled. Turn the controller off, leave for a few minutes and turn back on again.<br>·The motor may be faulty. Check the motor and associated connections and wiring.                            |
| 5     | Park Brake                                    | Either a park brake release switch is active or the park brake is faulty.<br>·Check the park brake and associated connections and wiring.<br>·Ensure any associated switches are in their correct positions.  |
| 6     | Drive Inhibit                                 | Either a stop function is active or charger inhibits or OONAPU condition has occurred.<br>·Release the stop condition (seat raised etc.)<br>·Disconnect the battery charger.<br>·Ensure the throttle is in Neutral when turning the controller on.<br>·The throttle may require re-calibration. |
| 7     | Speed Pot                                     | The throttle, speed limit pot. SRW or their associated wiring may be faulty.<br>·Check the throttle and speed pot and associated connections and wiring.  |
| 8     | Motor Voltage                                 | The motor or its associated wiring is faulty.<br>·Check the motor and associated connections and wiring.  |
| 9     | Other Error                                   | The controller may have an internal fault.<br>·Check all connections and wiring.  |

### OTHER PROBLEMS

- TIRE : Low tire pressure: pump up tires to 30~35 psi.
- Charger : During charging, light on charger doesn't change to green. Please refer to

section 5-2.

## CAUTION

### 1. Obstacle Climbing :

Your scooter can climb obstacles and curbs of up to 40mm / 1.6" in height. Never attempt to overcome an obstacle when on an uphill or downhill gradient!

Always approach obstacles straight on! Ensure that the front wheels and rear wheels move over the obstacle in one stroke, do not stop halfway!

### 2. The maximum gap the scooter can drive over is 100mm / 4",

·When driving scooter on ramp, adjust body center of gravity to keep scooter more safety.

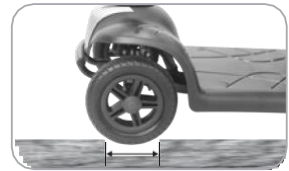
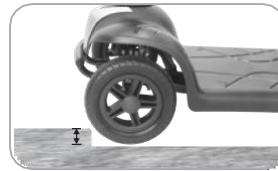

### Others :

1. Charge the batteries after each trip. If the scooter is not used for some time, batteries may lose their charge. Batteries should be charged at least once a month. Store in a dry location and disconnect batteries



2. Check the battery gauge before driving to prevent power depletion.

3. Batteries will have an aging phenomenon, where the storage capacity will gradually decrease. If batteries are damaged, contact your local dealer for proper disposal.

4. Do not disassemble battery and open sealed parts by yourself to prevent electric shock and burns from acid leakage,

5. Adjust speed to a slow speed when starting off to prevent sudden acceleration.

6. Never attempt to drive downhill backwards.

7. Avoid driving the scooter at night, in rain or bad weather.

## CLEANING YOUR SCOOTER

·Do not use any abrasive or scouring liquids for cleaning. Only use a damp cloth and gentle detergent.

·Do not use hose pipe or splash water directly onto the scooter as this may cause damage to electronics.

## MAINTENANCE

·User should inspect the scooter regularly to keep scooter in good running order.

·Check if the electrical cable connectors are fully connected.

·All maintenance and repair of scooter should be done by an authorized dealer.

### Seat Upholstery :

Only use damp cloth and a little soap to wipe the seat. Do not use abrasive cleaners as this will damage the seat.

### Storage :

·Please store the scooter in a dry location. If store the scooter in long time, please disconnect the battery terminals.

·Do not store your scooter where it will be exposed to source of direct heat, damp, oil, acid, alkaline, or where Ozone could be possibly generated. All of the above will minimize scooter / tire cycle and shorten its lifetime.

**SPECIFICATION**

|                          |  |
|--------------------------|--|
| Overall Length           | 44"  |
| Overall Width            | 23" (Armrest Width)  |
| Overall Height           | 37"  |
| Front Wheels             | 9"   |
| Rear Wheels              | 9"   |
| Weight W/ Batteries      | 121 lbs  |
| Weight Of Heaviest Piece | 38 lbs   |
| Max. Speed               | 5 mph  |
| Weight Capacity          | 350 lbs  |
| Ground Clearance         | 2"   |
| Grade Climbable          | 8 degree   |
| Curb Climbable           | 2"   |
| Turning Radius           | 55"  |
| Suspension               | Rear   |
| Brake                    | Electro-Mechanical   |
| Seat Type                | Swivel Light Weight Foldable   |
| Seat Width               | 18"  |
| Motor Size               | 250W, 4000 r.p.m   |
| Battery Size             | (2) 12V. 22Ah  |
| Weight of Battery Pack   | 34 lbs   |
| Travel Range             | 16 Miles   |
| Battery Charger          | 3A Off Board   |
| Electronics              | On / Off Key Switch,<br>Battery Level Indicator,<br>Speed Control Knob |

\*Subject to change without notice. ( Rev. 1, 2019/06/26 )