

# CHAPIN

## ⚠ WARNING ⚠

**WARNING: Improper use or failure to follow instructions can result in explosive failure causing serious eye or other injury.** For safe use of this product you must read and follow all instructions. Do not leave a pressurized sprayer in the hot sun. Heat can cause pressure build-up resulting in possible explosion. Do not store or leave solution in tank after use. Always wear goggles, gloves, long sleeve shirt, long pants and full foot protection when spraying. Never use any tool to remove pump if there is pressure in sprayer. Never stand with face or body over top of tank when pumping or loosening pump to prevent ejecting pump assembly and/or solution from striking and injuring you. Never pressurize sprayer by any means other than the original pump. Do not attempt to modify this sprayer. Replace parts only with manufacturer's original parts. **Never spray flammable, caustic, acidic, chlorine, bleach or other corrosive solutions or heat, pressure, or gas producing chemicals. Always read and follow chemical manufacturer's instructions before use with this sprayer as some chemicals may be hazardous when used with this sprayer.**

Sk-1154-1

## Parts, Piezas, Pièces



**Note:** Your particular sprayer may not include all parts pictured above.  
**Nota:** Es posible que este pulverizador en particular no incluya todas las partes que se ilustran arriba.  
**Remarque :** Votre pulvérisateur particulier pourrait ne pas inclure toutes les pièces illustrées plus haut.

### Congratulations!

You have just purchased a quality Chapin product.  
Register Your Sprayer Online @ [www.chapinmfg.com](http://www.chapinmfg.com) Questions? Do Not Return To Store.  
Call us @ 1-800-950-4458 or [www.chapinmfg.com](http://www.chapinmfg.com)

018261R0122

## 1. Hose to Tank

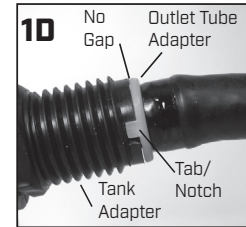
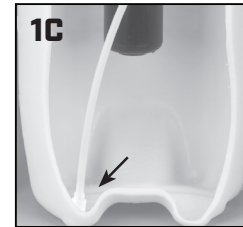
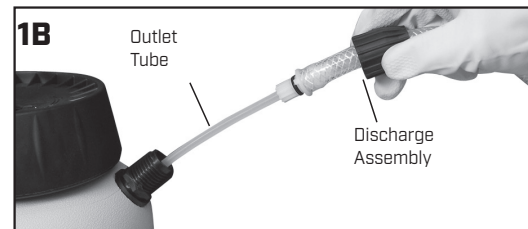
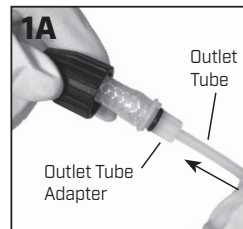

### Discharge/ Assembly

- Make sure white outlet tube is attached to outlet tube adapter (Fig. 1A).
- Insert the outlet tube portion of the discharge assembly into the tank adapter (Fig. 1B).
- Proper placement of white outlet tube (Fig. 1C).
- Firmly insert the outlet tube adapter into the tank adapter (Fig. 1D) Lining up tab with notches on the tank adapter.
- Firmly tighten the retaining nut to the tank adapter (Fig. 1E).

## 2. Extension wand and Nozzle Assembly

### Shut-off to wand to nozzle assembly

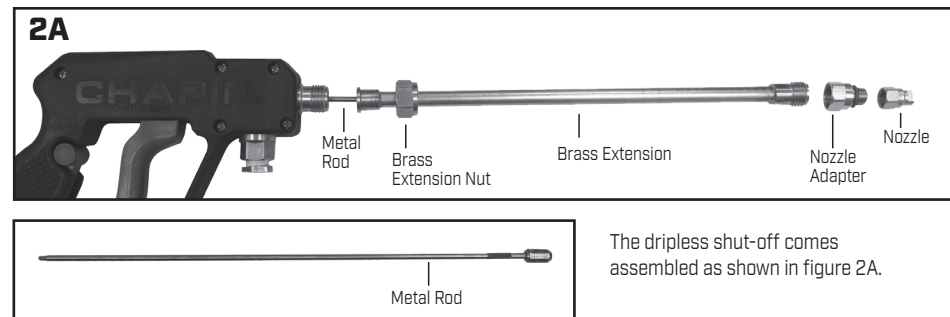

### Shut-off to nozzle assembly

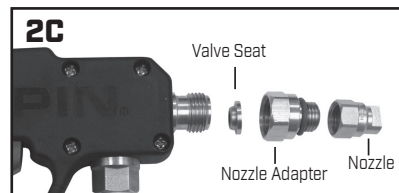
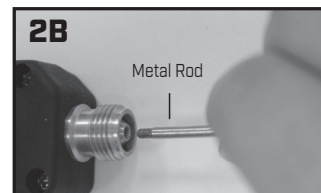

To attach nozzle directly to shut-off, unthread brass extension nut and metal rod. Assemble valve seat (included), nozzle adapter and nozzle to the shut-off as shown in figure 2C. Note orientation of valve seat. It will leak if assembled incorrectly.

## 3. Pre-Use Check

- 1) **Do:** Check tightness of hose nut to be sure hose is securely attached to the tank outlet.
- 2) **Do:** Inspect hose for deterioration, cracks, softness, or brittleness. If any of these conditions are found, replace hose before using. Replace with original manufacturer's parts only.
- 3) **Do:** Remove pump (see Filling, Pressurizing and Spraying Instructions), inspect interior and exterior of tank for signs of deterioration of body and bottom. Any sign of deterioration indicates possible tank weakening and could result in explosive bursting under pressure. If any of these signs are found, discard tank immediately and replace. Do not attempt to patch leaks, etc., as this could result in serious injury.
- 4) **Do:** Follow Filling, Pressurizing and Spraying Instructions, except use water only.
- 5) **Do:** Pump plunger 8-10 strokes and inspect for leaks.
- 6) **Do:** Direct shut-off away from you and open to make sure discharge is not clogged.
- 7) **Do:** If unit passes this test, release pressure (see Pressure Releasing Instructions), empty tank, and proceed with Filling, Pressurizing and Spraying Instructions.

## 4. Filling

- 1) **Do:** Turn pump handle counterclockwise and remove pump
- 2) **Do:** Prepare spray solution following all directions and safety warnings on chemical label.
- 3) **Do:** Fill tank to no more than the proper gallon marker. Do NOT: over fill to accommodate pump.
- 4) **Do:** Check pump to make sure that no grass or dirt is stuck to barrel. Replace pump in tank and tighten securely.

## 5. Pressurizing and Spraying



**Do:** Turn handle clockwise to tighten. Push handle down, turn 1/4 turn counterclockwise to release.

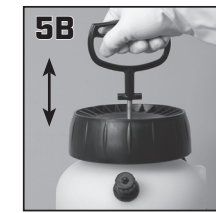

**Do:** Pump until you feel resistance.

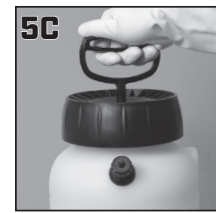

**Do:** Push handle, down, turn 1/4 turn clockwise to lock. Begin spraying. Re-pump sprayer as required to maintain spray force.

## 6. Lock Off

For safety lock-off feature (no-spraying), push trigger forward and rotate locking mechanism into lock-off position as shown in fig. 6A.

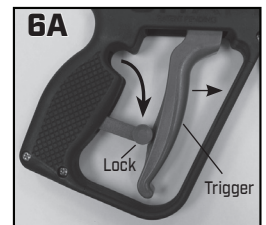

## 7. To Release Pressure

- 1) Your sprayer is equipped with a pressure relief/release valve (Fig. 7A). To release pressure lift and hold the cap until air is completely exhausted, OR, turn the valve slowly counterclockwise until you hear air escaping and wait air is completely exhausted Fig. 7B).
- 2) **Do:** Stay away from the sprayer until all air has escaped.

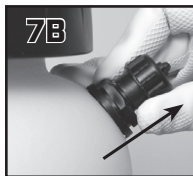
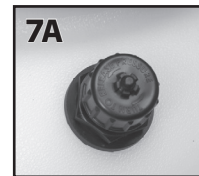

## 8. Wand Dock Clip

Choose the holder that fits your wand.



## 9. Care, Storage and Maintenance

- 1) **Do:** Follow chemical manufacture's instructions for cleaning. Rinse thoroughly with recommended solvent. Follow Filling, Pressurizing and Spraying Instructions, except pump unit only 8-10 strokes. Be sure that the wand and nozzle are thoroughly rinsed after each use.
- 2) **Do:** Open shut-off and allow recommended solvent to run through discharge assembly.
- 3) **Do:** Release pressure (Follow Pressure Release Instructions), remove pump and empty sprayer.
- 4) **Do:** Store sprayer tank upside down, with pump removed, in a warm dry location.
- 5) **Do:** Periodically oil pump by dropping 10-12 drops of light oil down pump rod through opening in cover.

# CHAPIN

P.O. Box 549 700 Ellicott St.  
Batavia, NY 14021-0549 U.S.A.  
1-800-950-4458 [www.chapinmfg.com](http://www.chapinmfg.com)

