

# Ghost K9 Camera

## Mobile Ad Hoc Network Enabled

The NEW Ghost K9 Camera (MANET K9 Camera) from Tactical Support Equipment Inc. is housed in a Waterproof Enclosure. The system now incorporates a selectable Color Day/Night Camera or High Resolution Thermal Camera. The Infrared Illuminator is now controlled by the Day/Night camera sensor, so it is able to brighten or dim the Illuminator as required, which saves overall battery life. The Thermal Camera operates at a full frame rate, which produces no lag in video. With selectable White Light and Infrared Strobe Light. The Ghost K9 camera is GPS enabled as well.

The Ghost K9 Camera is viewed and controlled by a K9 Plug-In for the Android Tactical Assault Kit (ATAK), which is run on Android Device. User can view and record video and view K9 Camera and K9 Handler location on a map with ATAK.

The Ghost K9 Camera now operates on the Persistent Systems Wave Relay<sup>®</sup> Mobile Ad Hoc Networking (MANET) System. The Ghost K9 Camera operates as a part of the Wave Relay<sup>®</sup> Ecosystem. User can select between 10-Watt L-Band and S-Band Radio Modules. C-Band Radio Modules are also available on request. Security of the link is ensured by Crypto Modes: AES256 Encryption and SHA-256 HMAC.



**Part #:**  
**TSE-K9-GHST-T-L**  
**TSE-K9-GHST-T-S**  
**TSE-K9-GHST-T-C**



## Features

- Waterproof
- Mobile Ad Hoc Network Enabled
- Day/Night and Thermal Cameras
- View Video, Location and Control in ATAK
- Run Time of 4.5hrs
- Interchange Radio Modules to change Bands

**Tactical Support Equipment Inc.**  
4039 Barefoot Road  
Fayetteville, NC 28306  
[www.tserecon.com](http://www.tserecon.com)

For More Information  
Contact [sales@tserecon.com](mailto:sales@tserecon.com)



**Phone: 800.889.4030**  
**Phone: 910.425.3360**  
**Fax: 910.425.3361**

# Specifications (TSE-K9-GHST-T-L or TSE-K9-GHST-T-S or TSE-K9-GHST-T-C)

## Ghost K9 Camera Transmit Subsystem

Day/Night Camera	Image Sensor	1/3.2-inch BDI CMOS image sensor
	Minimum Illumination	0.005 lx F1.8 (AGC=54dB)
	Lens	2.5mm (Matches Field of View of Thermal Camera)
Thermal Camera	Spectral Band	LWIR   7.5 $\mu\text{m}$ – 13.5 $\mu\text{m}$
	Resolution	640 x 512 Pixels
	Full Frame Rate	60Hz baseline; 30 Hz runtime selectable
	Lens	4.9mm (Matches Field of View of Day/Night Camera)
IR Illuminator		850nm LED (Auto Brightness controlled by Camera Sensor)
White Light Illuminator		Visible LED
IR Strobe		850nm LED
Remote Control		Switch between Day/Night Camera and Thermal Camera, Turn White Light ON/OFF, Turn IR Illuminator ON/OFF, Turn IR Strobe ON/OFF
Radio		Persistent Systems Embedded Module (Wave Relay® Ecosystem)
Network		Mobile Ad Hoc Network (MANET) with MIMO Technology
Frequency Range		L-Band 1350-1390MHz, S-Band 2200-2507MHz, C-Band 4400-5000MHz or 5100-6000MHz (User Interchangeable Frequency Module)
GPS		Situational Awareness, Cursor-on-Target Compliant, Adjustable rep rate
Max. Aggregate Transmission Power		10W (3.3W per RF Chain)
Crypto Modes		CTR-AES-256 Encryption and SHA-256 HMAC
Battery		AN/PRC-148 Battery, AN/PRC-152 Battery, MPU5 Battery
Housing Material		Aluminum (6061-T6)
Run Time		4.5 hrs
Range		800m Line of Sight and 300m Non-Light of Sight/Indoors
Finish		Black Anodized Aluminum
Operating Temperature		-40°C to +60°C (-40°F to +140°F)
Environmental		Built to IP67 (Designed to MIL-STD)
Weight		2.84 lbs.
Dimensions		See drawings on next page.

**Tactical Support Equipment Inc.**  
4039 Barefoot Road  
Fayetteville, NC 28306  
[www.tserecon.com](http://www.tserecon.com)

For More Information  
Contact [sales@tserecon.com](mailto:sales@tserecon.com)



**Phone: 800.889.4030**  
**Phone: 910.425.3360**  
**Fax: 910.425.3361**

## Specifications

(TSE-K9-GHST-T-L or TSE-K9-GHST-T-S or TSE-K9-GHST-T-C)

### Ghost K9 Camera Transmit Subsystem

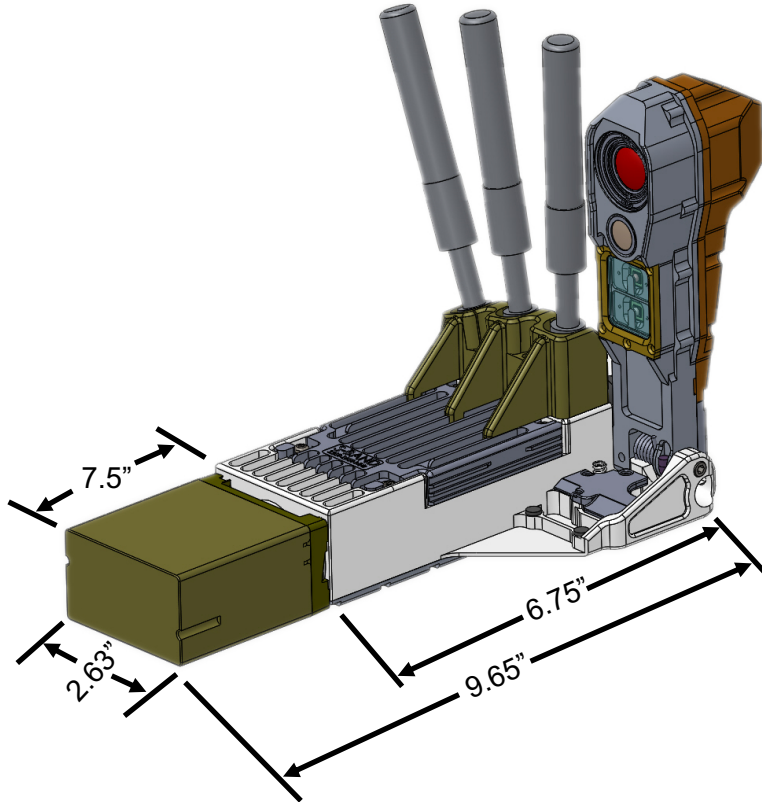

Antenna Length will vary with Band ordered

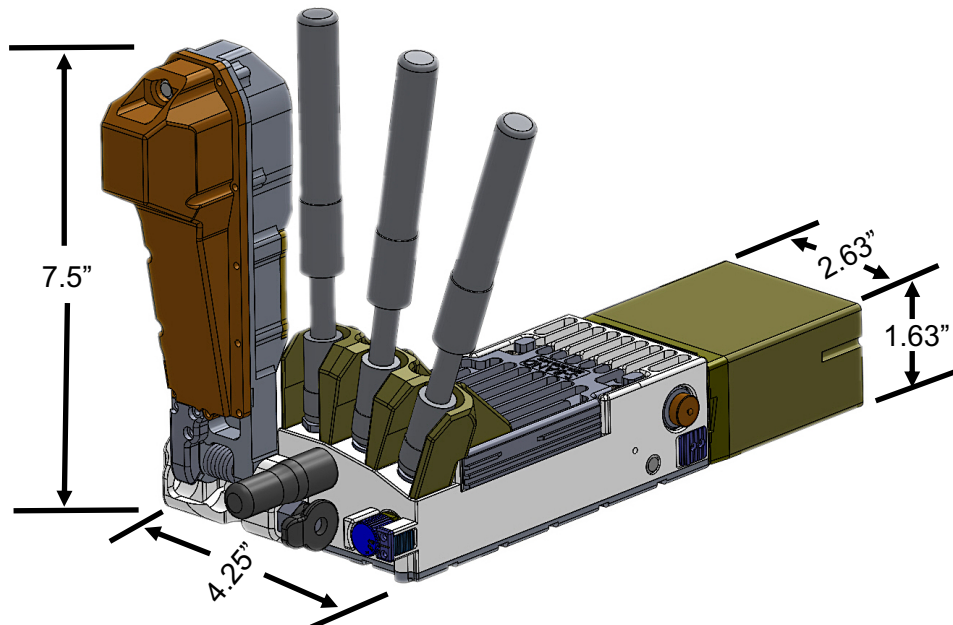

Tactical Support Equipment Inc.

4039 Barefoot Road  
Fayetteville, NC 28306

[www.tserecon.com](http://www.tserecon.com)

For More Information  
Contact [sales@tserecon.com](mailto:sales@tserecon.com)



Phone: 800.889.4030

Phone: 910.425.3360

Fax: 910.425.3361

**Specifications  
(TSE-K9-GHST-R1-L or TSE-K9-GHST-R1-S or TSE-K9-GHST-R1-C)**

**Ghost K9 Camera Receive and Control Subsystem**

**MPU5\*\***

<b>Radio</b>	Persistent Systems MPU5
<b>Network</b>	Mobile Ad Hoc Network (MANET) with MIMO Technology
<b>Frequency Range</b>	L-Band 1350-1390MHz, S-Band 2200-2507MHz, C-Band 4400-5000MHz or 5100-6000MHz (User Interchangeable Frequency Module)
<b>GPS</b>	Situational Awareness, Cursor-on-Target Compliant, Adjustable rep rate
<b>Max. Aggregate Transmission Power</b>	10W (3.3W per RF Chain)
<b>Crypto Modes</b>	CTR-AES-256 Encryption and SHA-256 HMAC
<b>Battery</b>	AN/PRC-148 Battery, AN/PRC-152 Battery, MPU5 Battery

**Dual PTT\*\***

<b>Device</b>	Part of the Wave Relay® Multicast VoIP Solution
<b>Operation</b>	Half-Duplex or Full-Duplex Configurations Available
<b>Connections</b>	EUD, Headset and MPU5

**Headset\*\***

<b>Operation</b>	Dual Channel
------------------	--------------

**End User Device (EUD)\*\***

<b>Device</b>	Android TE Phone
<b>Software</b>	ATAK and Radio Host Monitor
<b>Case</b>	IP-6X Dust/Shock Proof
<b>Data Displayed</b>	Location Information for K9 Handler and K9 Camera Mapping, Video, Controls, Battery Life
<b>Video Recorder</b>	On-board Recording of Video and Still Images

**\*\*Please visit [www.persistentsystems.com](http://www.persistentsystems.com) for detailed information.**



**Part #:  
TSE-K9-GHST-R1-L  
TSE-K9-GHST-R1-S  
TSE-K9-GHST-R1-C**

**Tactical Support Equipment Inc.**  
4039 Barefoot Road  
Fayetteville, NC 28306  
[www.tserecon.com](http://www.tserecon.com)

For More Information  
Contact [sales@tserecon.com](mailto:sales@tserecon.com)



**Phone: 800.889.4030  
Phone: 910.425.3360  
Fax: 910.425.3361**