

chameleon

adam goodrum

n

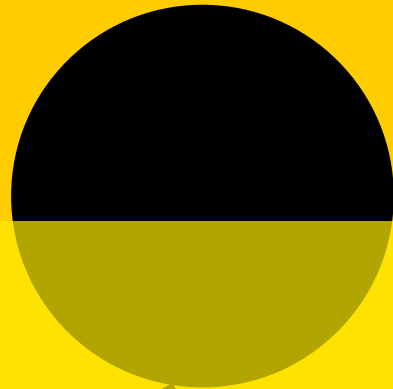
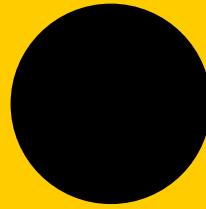

a



u





adam goodrum

previous page
chameleon table system

featured within the NAU Gallery
alongside SIA by Tom Fereday,
Jolly by Kate Stokes, and
Bower by Adam Goodrum.

opposite page
Chameleon round table

round-vertical 3-leg, 900mm dia
Natural ash top with black base.
Shown with Strand chairs by
Adam Cornish in natural ash shell
and black frame, and Bower screens
in black-stained ash and
charcoal weave.

A firm believer that every environment is defined by the objects within it, Adam Goodrum designs with the philosophy that an object must therefore justify its existence – through its story and detailing. For this reason, his designs celebrate process and craftsmanship, and accentuate components and joinery to create functional pieces with spirit and personality. In recent years, Goodrum's work has been awarded a host of design accolades including the NGV Rigg Prize, Vogue x Alessi Design Prize, Indesign Luminary Award and the Idea Awards Editor's Medal. He has also been commissioned to design pieces for several global luxury brands including Veuve Clicquot, Alessi and Cappellini.

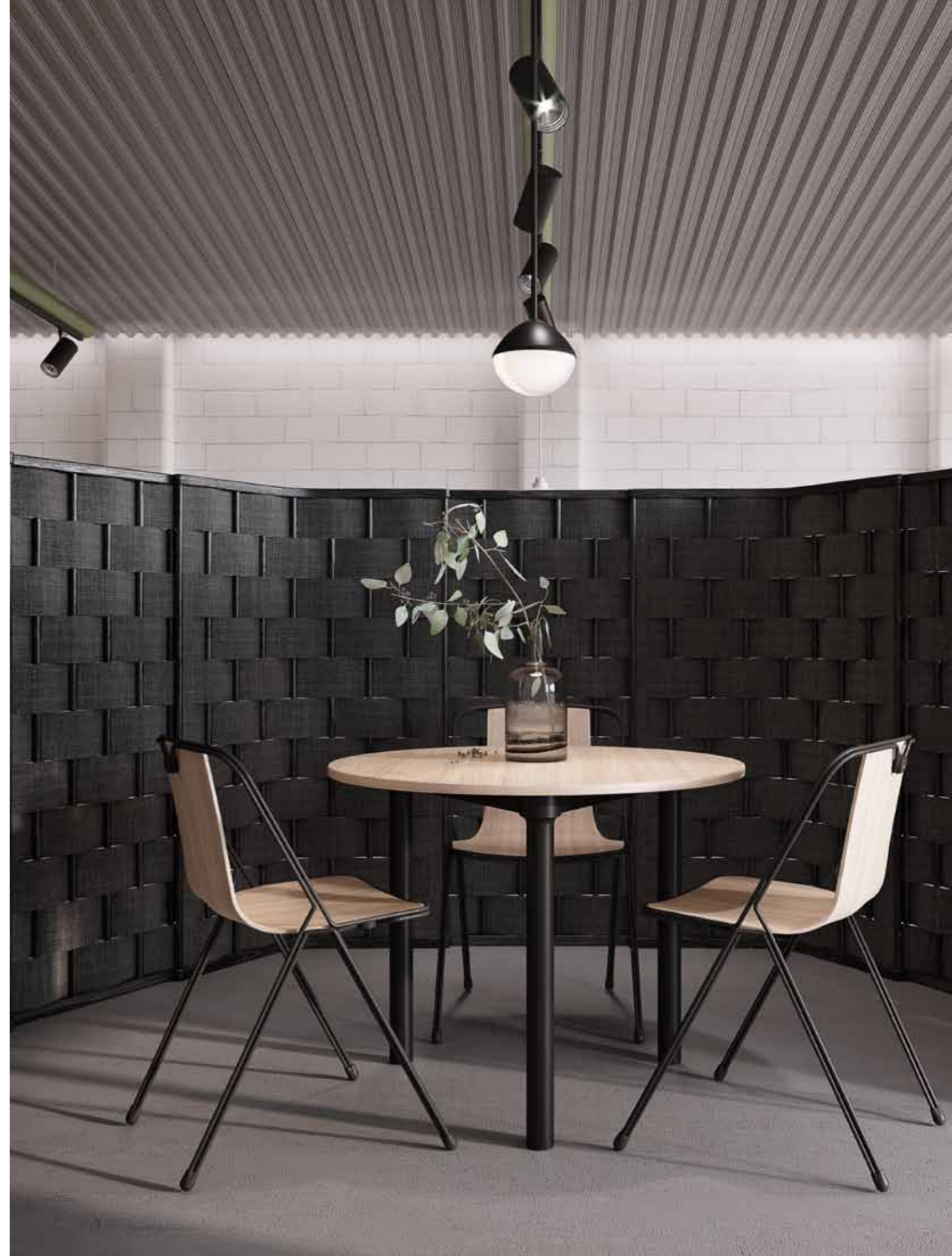

chameleon



opposite
chameleon round table

flat-angled 4-leg, 1400mm dia.
Natural oak top with off-white
base. Shown with Strand chairs
in natural oak shell and white
frame, Jolly wall lights in black,
and Bell pendant in white.

Named after its ability to cleverly adapt to its environment, Chameleon is an agile structure that takes commercial configuration to new levels. Its range of articulated features are a product of extensive engineering, offering limitless dimensional, typological and aesthetic table solutions with a singular design language. With an overall aesthetic that reflects the seamlessness of its mechanics, the Chameleon is refined in its engineering, functional in design and versatile in form, ready to adapt to the dynamic world for which it was designed.



refined

chameleon rectangular table
flat-angled multi-leg

3500mm x 1400mm in two-pieces.
Natural walnut top with black base.
Shown with Molloy chairs in natural
walnut, Jolly wall light in black,
and Jolly double pendant in brass.

Made from a series of castings that fluidly interact, the Chameleon features a structurally refined Axis-Joint that enables 15-degree frame and leg articulations - a single mechanical solution able to configure multiple modular formations. A result of over two years of refinement, the Axis-Joint fulfills the need for a piece of complex engineering that is not compromised in usability or aesthetics. The minimal castings of the joint are integrated seamlessly into the structure of the Chameleon, creating an overall aesthetic that is visually clean yet inherently complex.

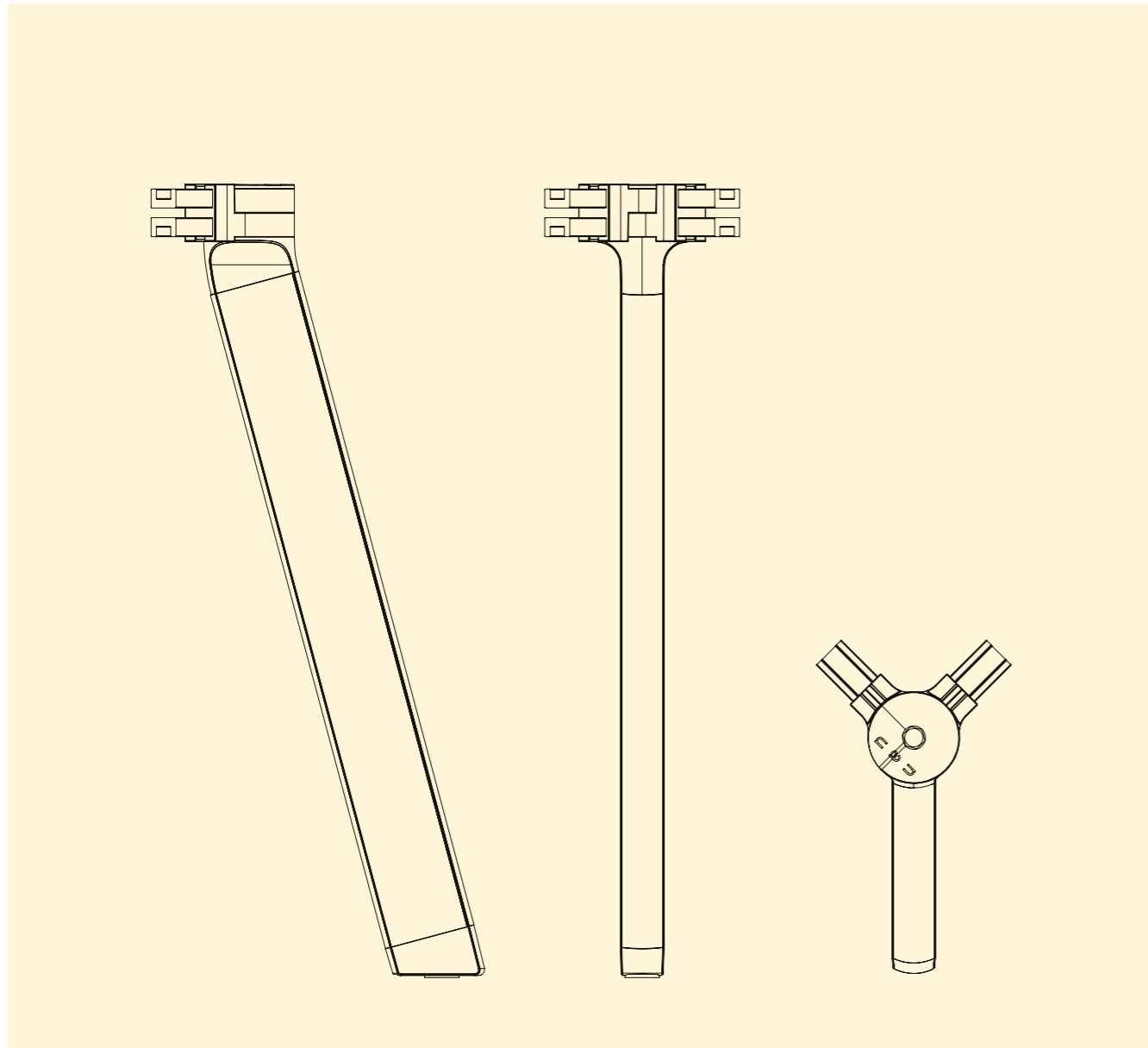

functional

chameleon workstation
flat-angled multi-leg

1400mm x 700mm in 4x2 configuration.
Natural ash top with off-white base.
Shown with SIA chairs in natural ash
and black frame.

Available in a range of top finishes installed to a rigid modular aluminum frame, the Chameleon is strong yet lightweight. Its legs are comprised of a solid aluminum extrusion with a lay-in cable routing and a removable aluminum clip cover, allowing for ease and flexibility in power and data supply. Each leg features a discrete adjustable M10 glide for on-site leveling, with retrofittable castor option.

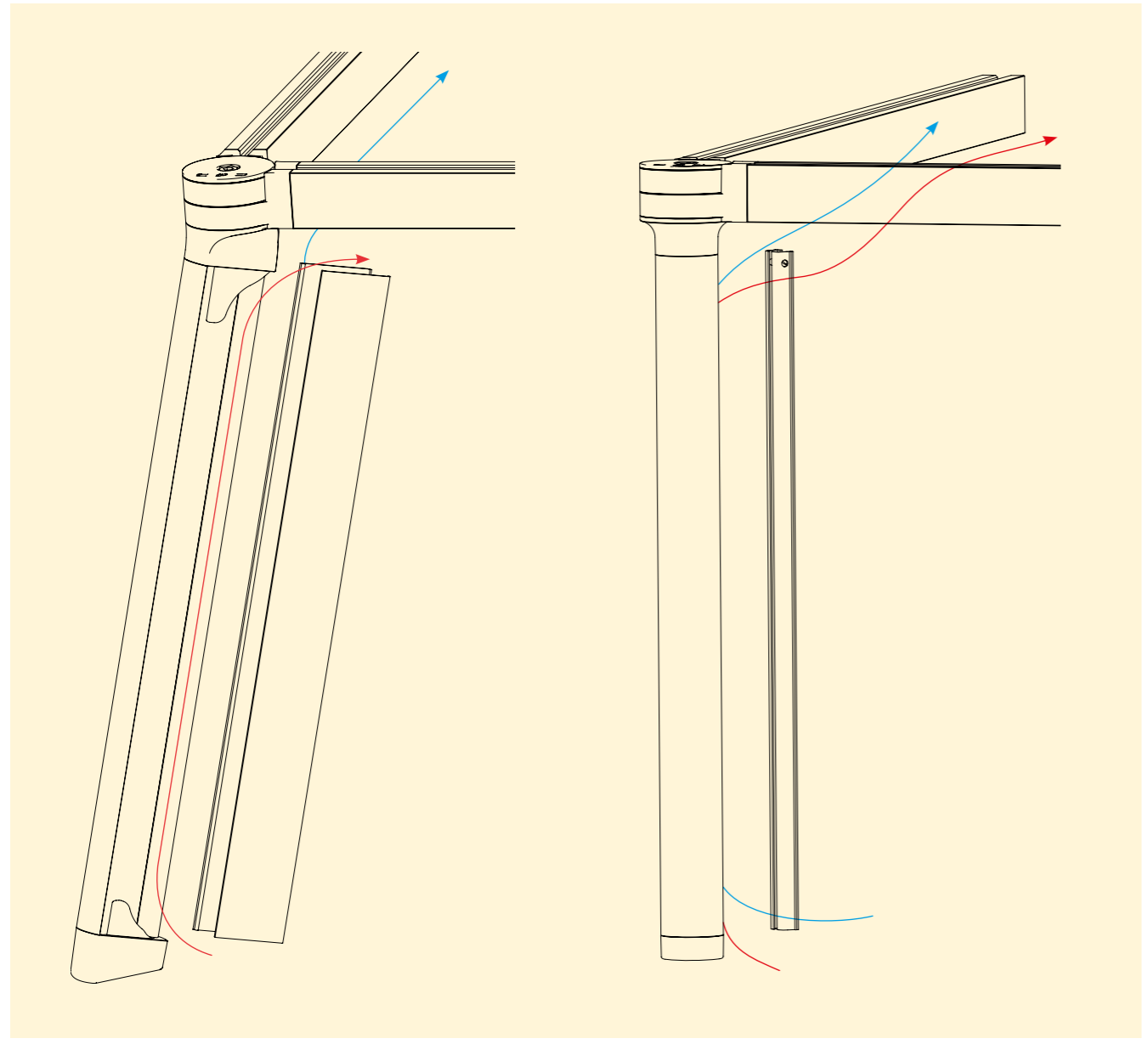

versatile

chameleon D-End high table
flat-angled 5-leg

800mm x 1200mm. Black laminate top with black base, 1100mm high. Shown with 750mm high Rev stools by Adam Cornish in silver, and Bower screens in black-stained ash and charcoal weave.

Multiple size and shape formations are made possible by the Chameleon's cleverly engineered structure and articulating features, available in 2 height options catering to both sitting and standing solutions. Inherently versatile, the Chameleon is available with either a flat-angled leg for a streamlined profile or a round-vertical leg, to meet the functional and aesthetic needs of any environment it inhabits.

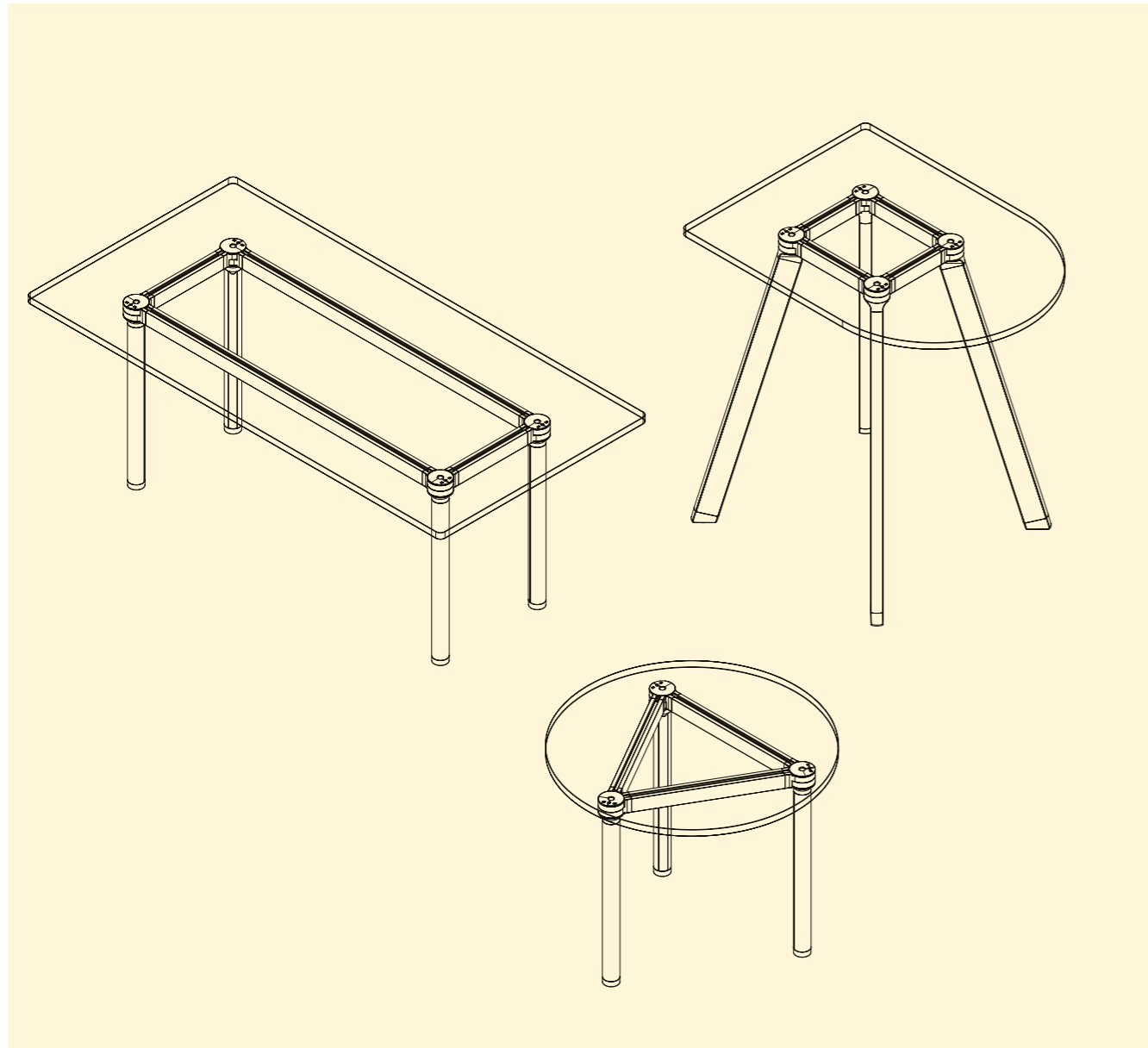

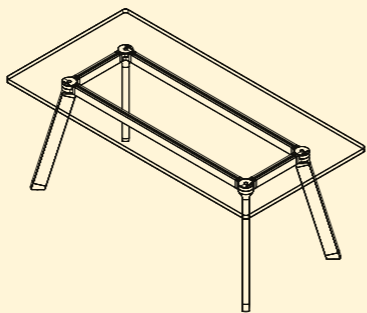
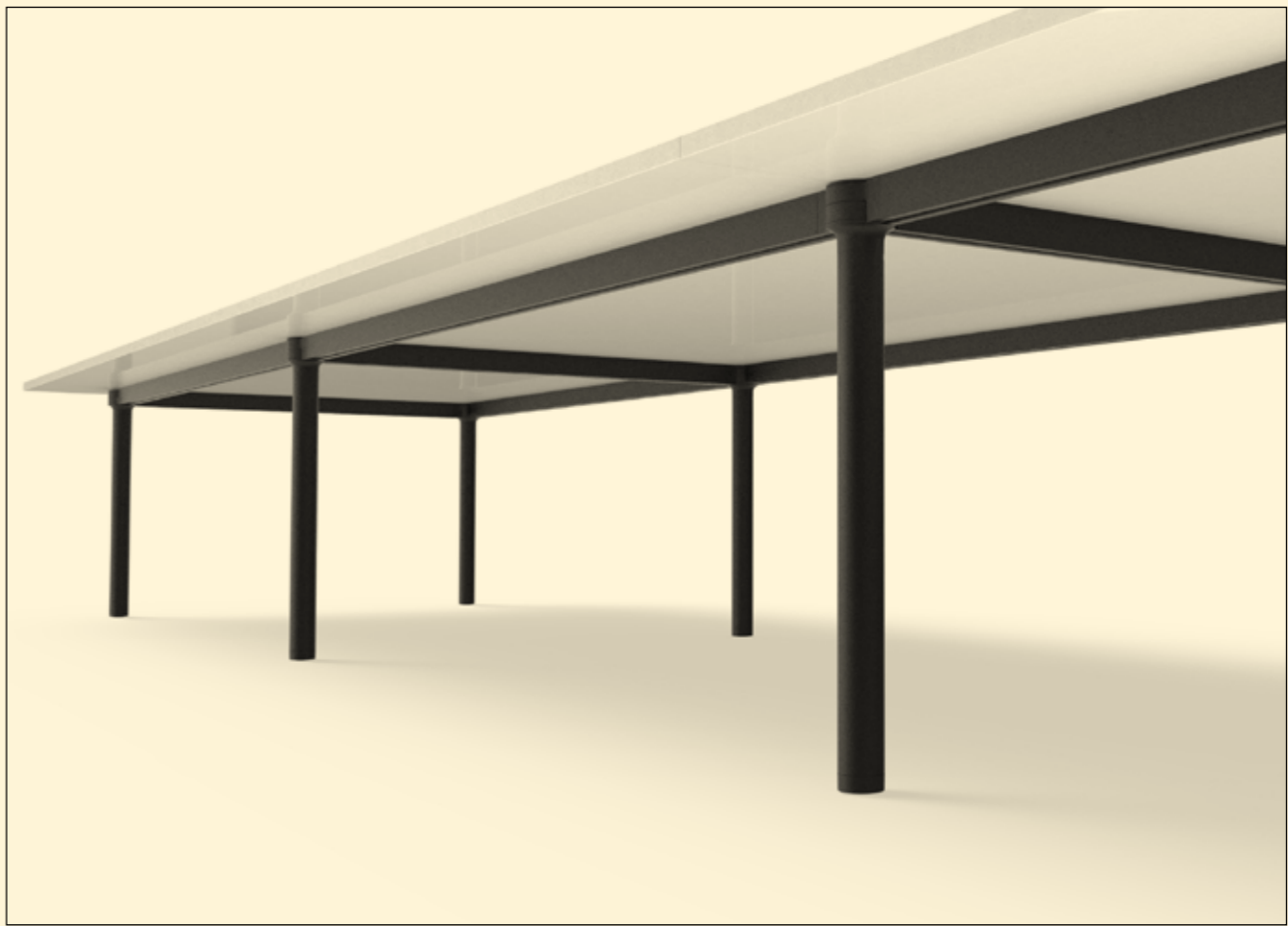

14

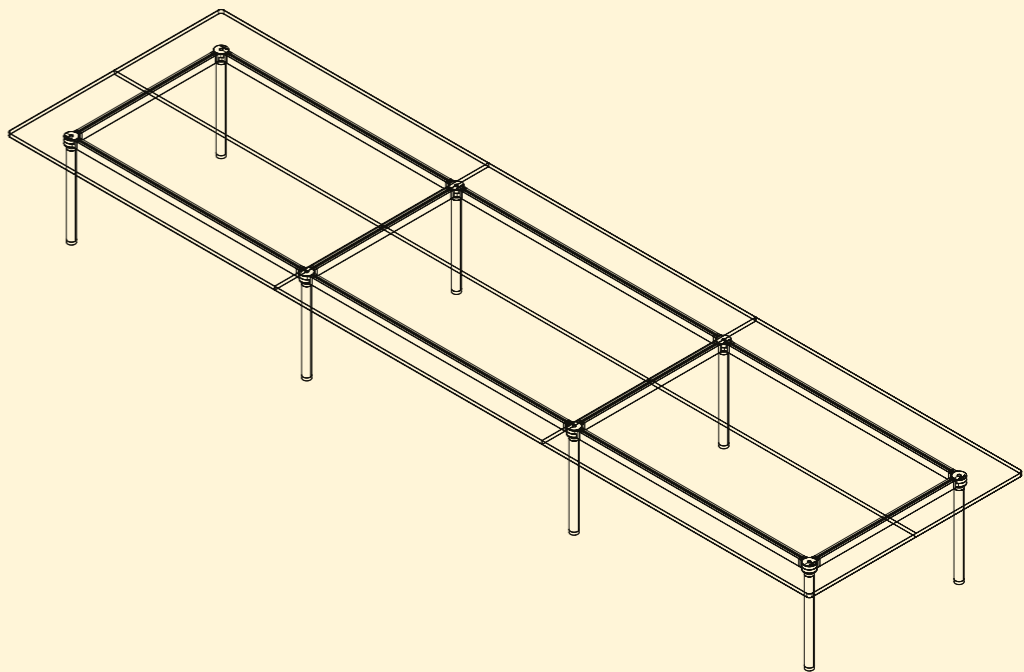

15

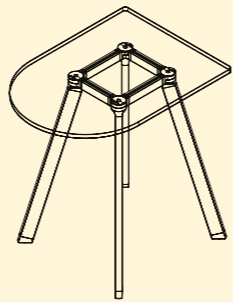

16

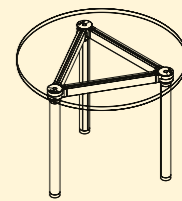

17

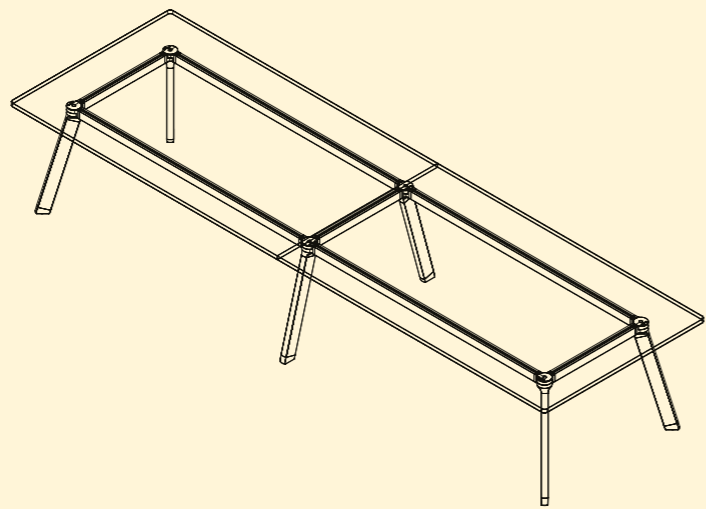
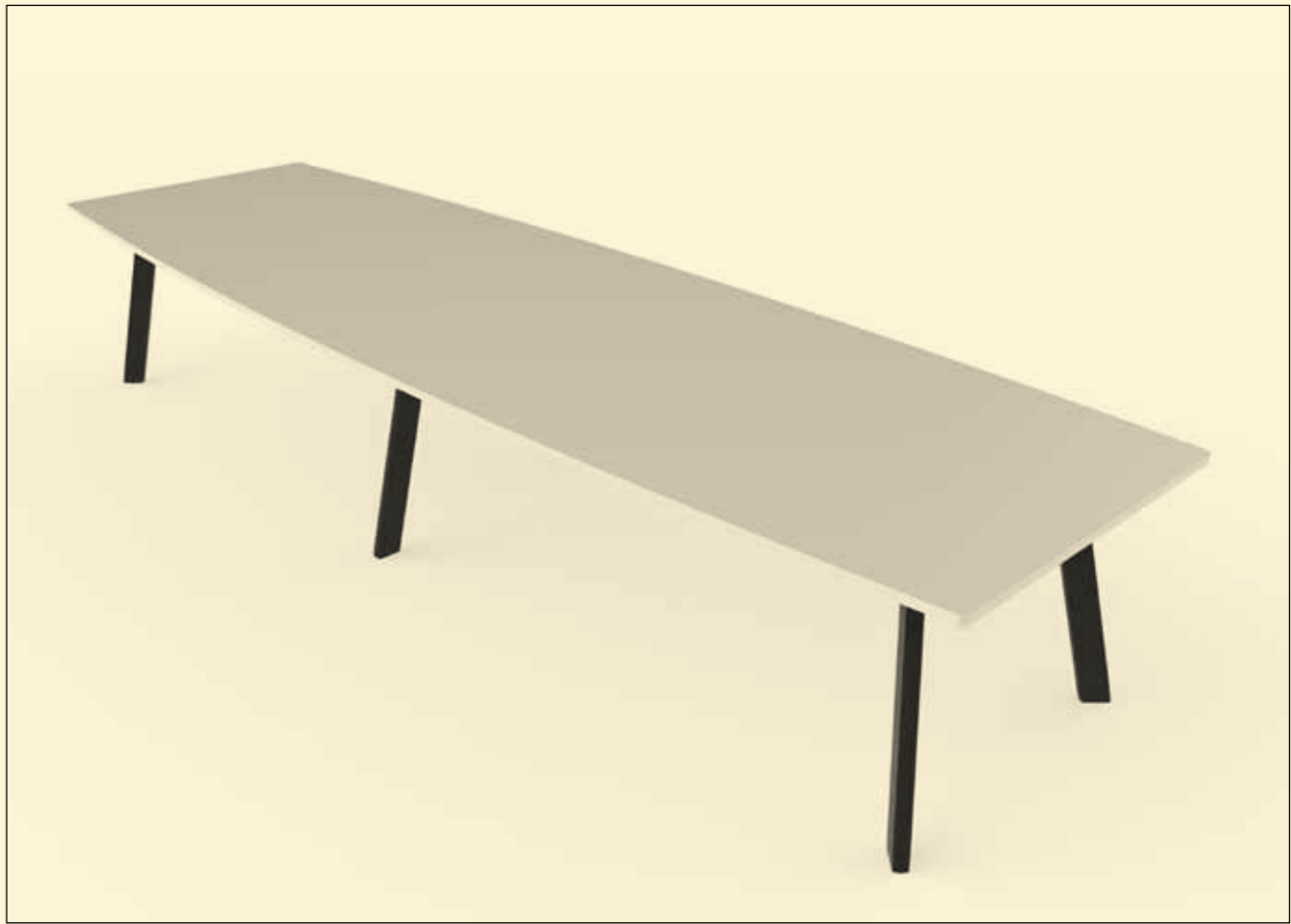

18

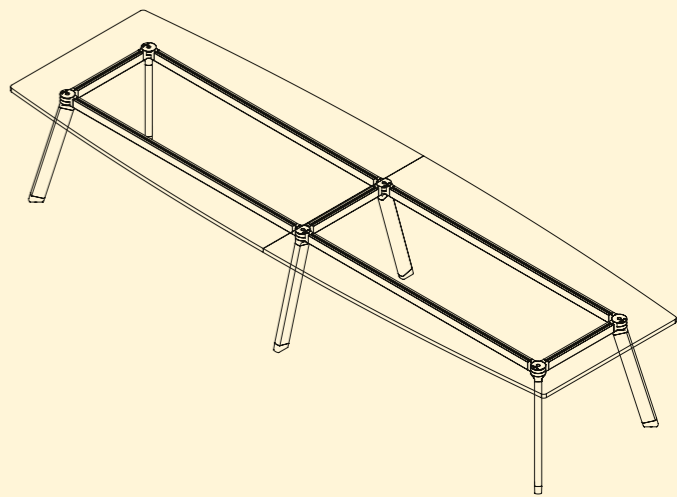

19

shape and size options

1. **Circular, 3-leg**
Ø800mm (min), Ø1000mm (max)
2. **Circular, 4-leg**
Ø1100mm (min), Ø2000mm (max)
3. **Circular, 6-leg + 1 centre**
Ø2100mm (min), Ø2400mm (max)
4. **Square/Rectangular/Elliptical/
Super Elliptical, 4-leg**
800mm x 800mm (min),
2400mm x 2400mm (max)
5. **Rectangular/Elliptical/
Super Elliptical, multi-leg**
2450mm L x 800mm W (min)
6400mm L x 2400mm W (max)
6. **D-End, 5 leg (flat-angled leg only)**
1500mm L x 1000mm W (min)
3000mm L x 1500mm W (max)
7. **Barrel, multi-leg**
1600mm L x 800/1000mm W (min),
6400mm L x 2200/2400mm W (max)
8. **Workstation, multi-leg**
1200 L x 600 W mm (min)
1800mm L x 900mm W (max) per "station"
9. **Custom shapes**
Frame articulation allows corner joint
positions at 15 degree intervals to suit
endless possibilities in top shapes.
Enquire within.

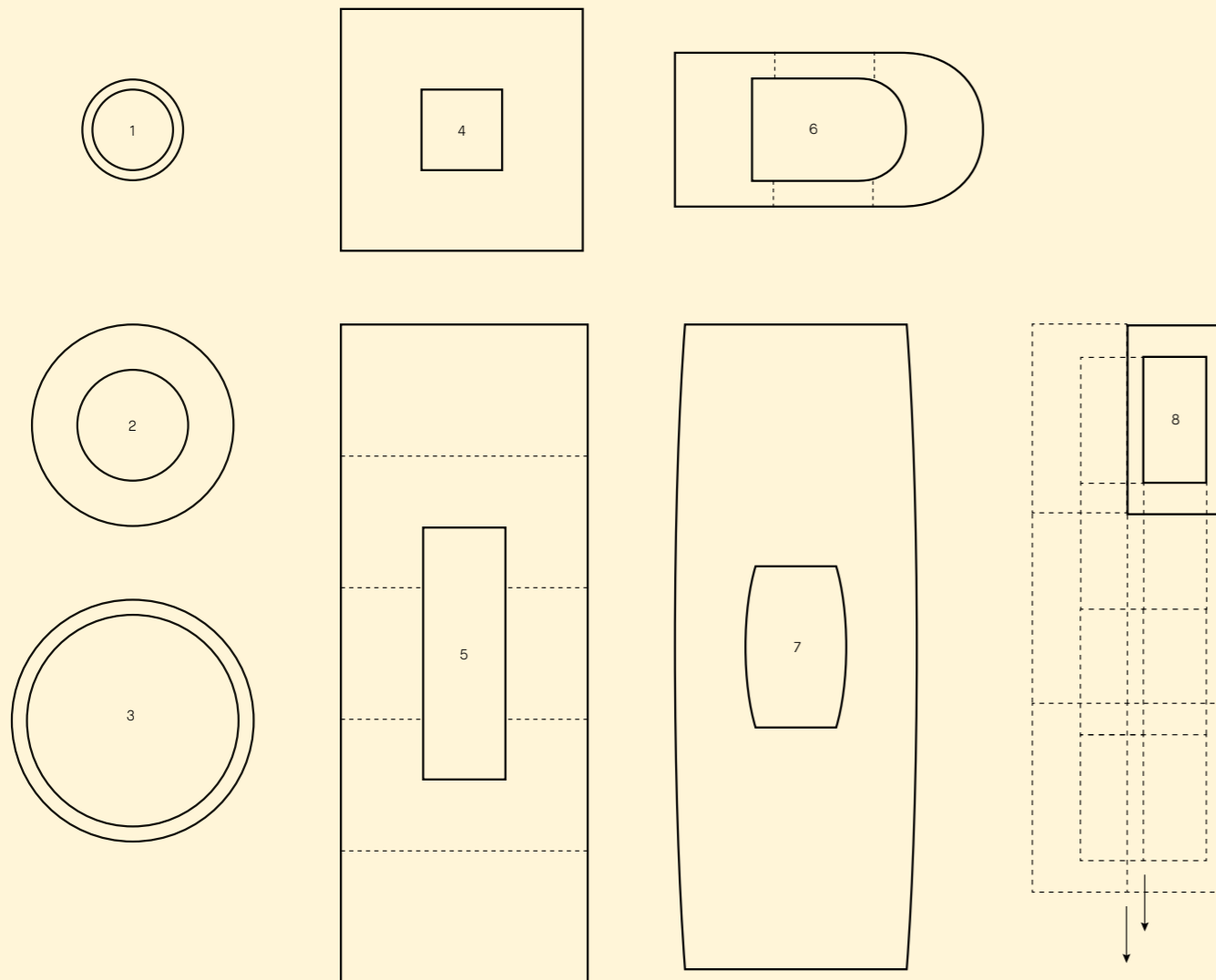

colour

Black
Off-white

top material

Suitable with a solid timber, veneer
and laminate table top options

leg shape

Flat-angled
Round-vertical

leg angle

The flat-angled leg articulation allows
for leg positions at 15 degree intervals

cable management

Flat-angled and round-vertical legs feature
lay-in cable routing with power & data separation
capabilities for up to 6 cables at 11.5mm diameter,
with removable clip cover.

feet

Hidden adjustable M10 glide (standard)
Felt (optional)
Castor, Black or White

Height

(includes 25mm table top)
715mm
1050mm

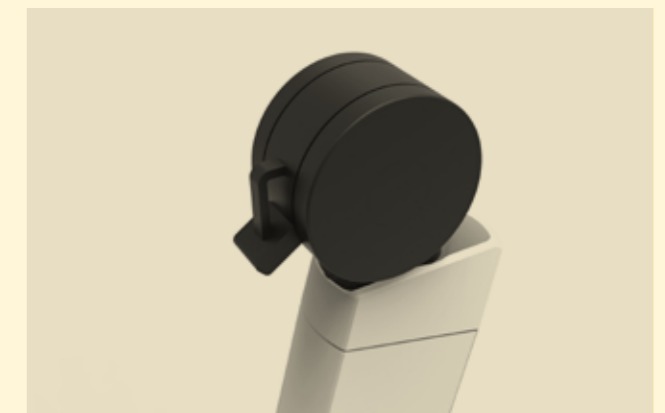

denfair 2019



denfair 2019



awards 2019

Good Design Awards



'Best Commercial Product' Denfair



nau 2019 campaign



for pricing, distribution, sales
and marketing please contact
info@naudesign.com.au

nau is represented exclusively
in Australia & New Zealand
by Cult Design

www.naudesign.com.au
[@nau_design](#)

Copyright
Corporate Culture Australia Pty Ltd

Graphic Design / Branding
Design by Toko

3D Renders
Large Arts