

Ripstop[®] ByTheRoll

ZIPPERED ENTRY HAMMOCK SOCK KIT

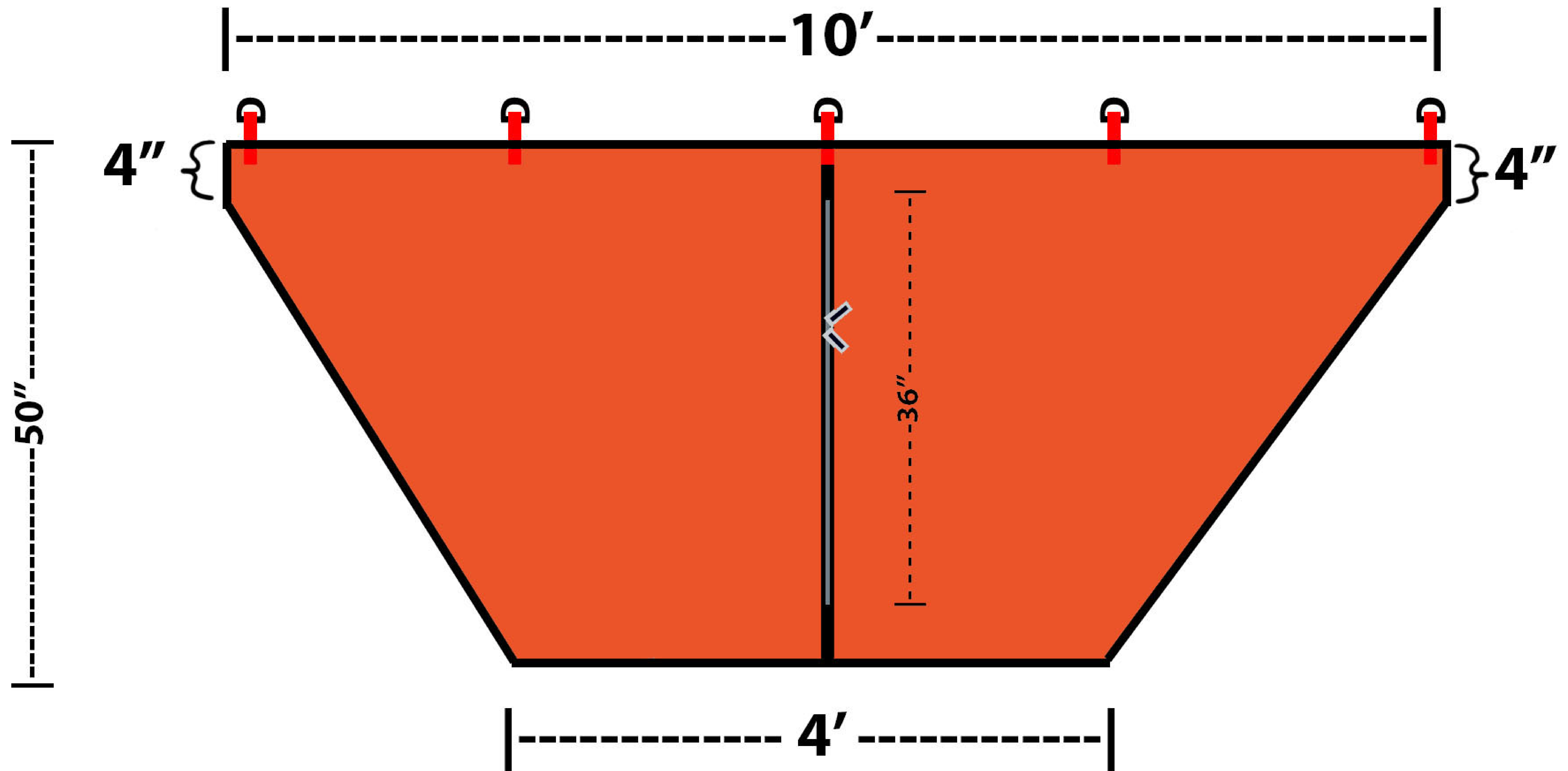

*Not to scale

STEP 1: Attach sliders to your zipper coil



What's in the Kit:
7 yards Calendered material
4' #3 zipper coil
2 #3 double sided zipper pulls
1' of 3/4" grosgrain
3 cordlocks
3' shock cord

STEP 2: After adding sliders, sew 6" of 3/4" Grosgrain to each end of the zipper

Use a box stitch to attach grosgrain to zipper coil

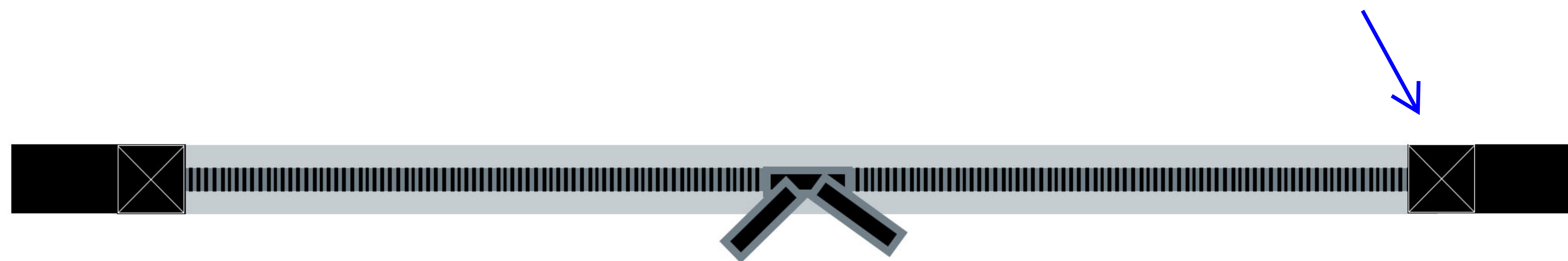

STEP 3: Cut 2x Panels 126" long x 50" wide *



STEP 4: Cut one panel in half at 63"



STEP 5: Sew each half of panel to zipper

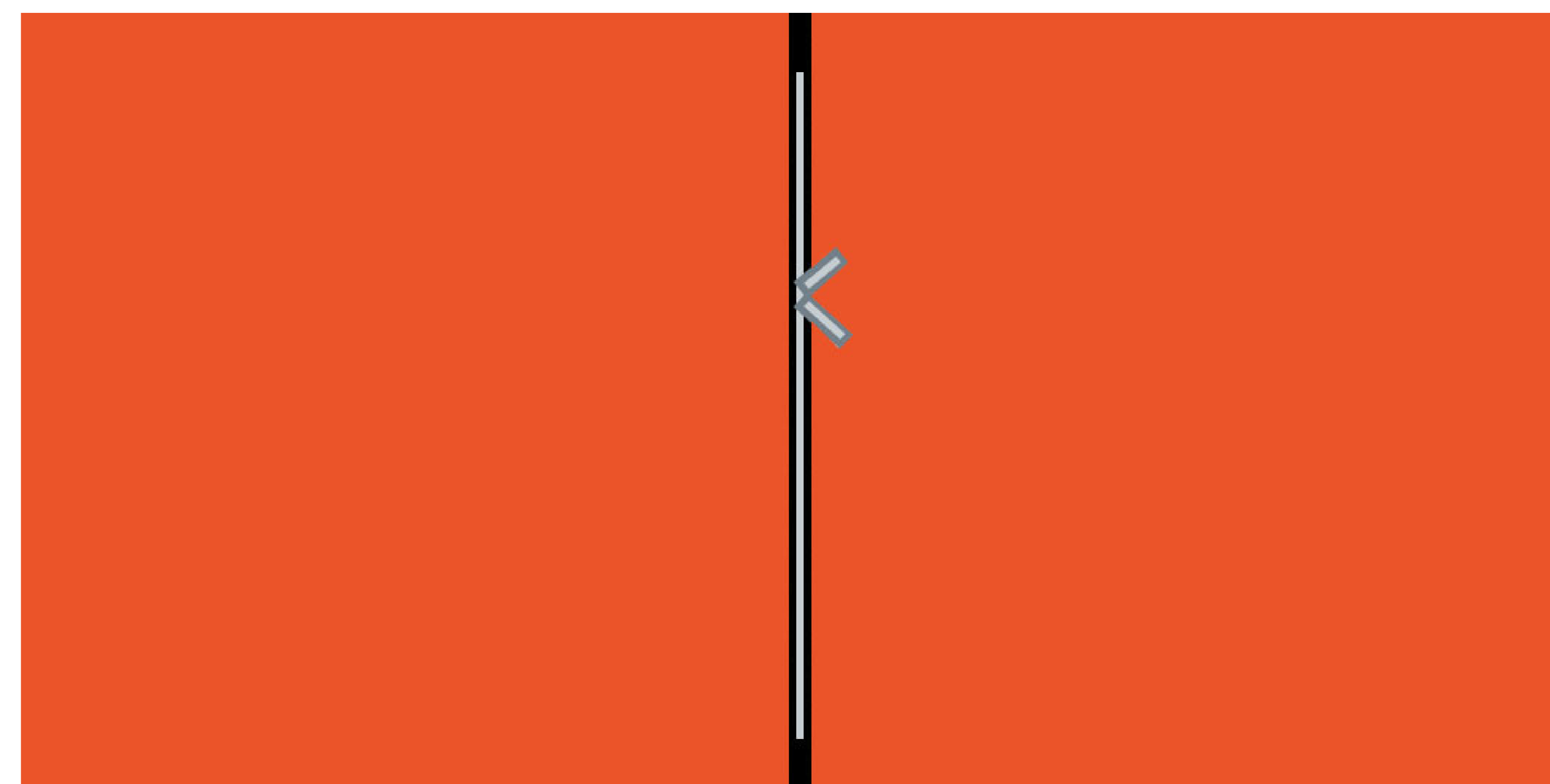

STEP 6: measure and cut each panel as shown 4" on the ends (Yellow) and 2' off center on the bottom.

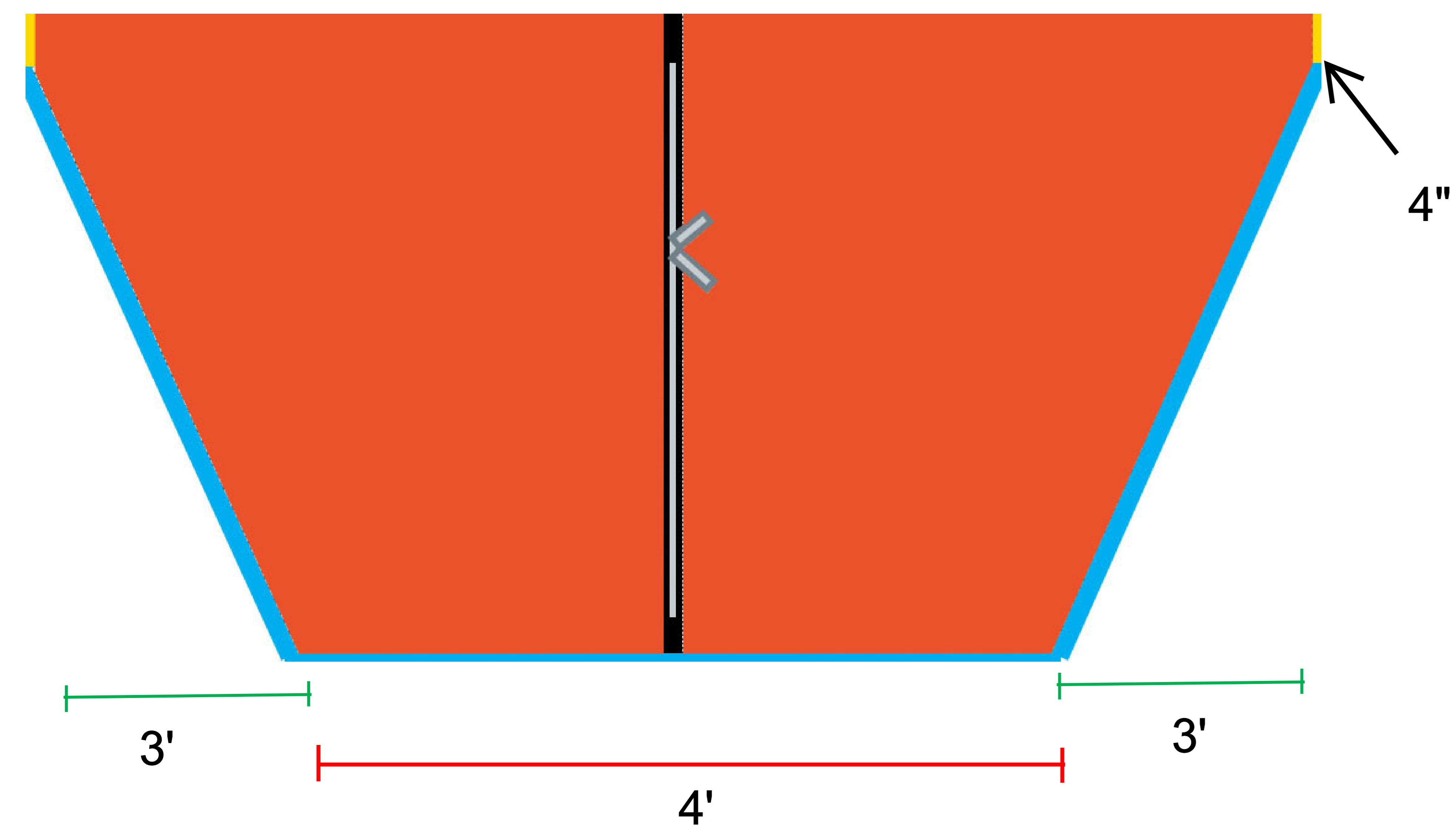

STEP 7: Repeat with the second panel.



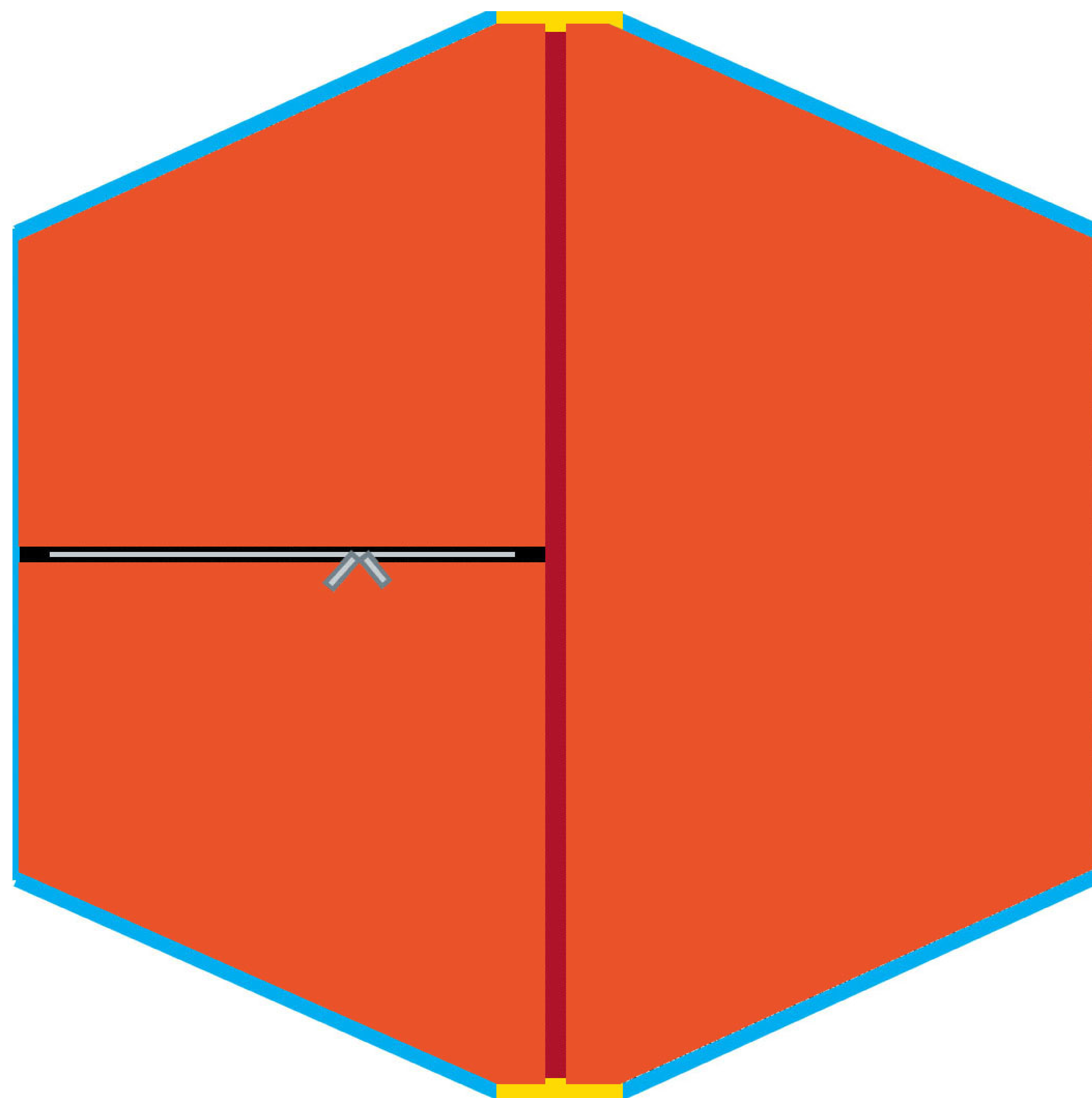

STEP 8: Join your panels along the ridgeline (Red)

STEP 9: Sew channels for your shock cord closures at the end channels. (Yellow) **

** Alternate instructions: Use Velcro or Omnitape to close the end channels.

STEP 10: With your sock inside out, sew the perimeter of your project closed (Blue)

STEP 11: Turn your net right side out. Insert shock cord into end channels.

STEP 12: Enjoy a warmer nights sleep.