



Installation Instructions

ELEKTROMAT

SI 17.60 FU-25,40

Model: 10003900 10014

-en-

Status: 02.02.2022



GfA ELEKTROMATEN GmbH & Co. KG
Wiesenstraße 81
D-40549 Düsseldorf
🌐 www.gfa-elektromaten.de
✉ info@gfa-elektromaten.de

Table of contents

1	General safety information	4
2	Technical data	6
3	Special version with vent screw	7
4	Integrated safety brake	8
5	Mechanical installation	9
6	Electrical installation	14
7	Limit switch setting	15
8	Motor connection	16
9	Limit switch connection	16
10	Emergency manual operation (hand chain operator)	17
11	Completion of commissioning / testing	19
12	Disposal	22
13	Declaration of incorporation / Declaration of conformity	23

Symbols



Warning - Potential injury or danger to life!



Warning - Danger to life from electric current!



Note - Important information!



Requirement - Required action!

Schematic representations are based on product examples. Deviations from delivered products are possible.

1 General safety information

Specified use

The drive unit is intended for vertically moving doors that need to be secured against dropping. A safety brake is integrated into the gearbox. The drive unit must be mounted directly on the shaft of the door.

The drive unit must be protected against moisture and aggressive environmental conditions (such as corrosive substances). The drive units are only suitable for indoor use. Appropriate protective measures must be taken for outdoor installation. The drive unit is not intended for hazardous areas. The values specified in the technical data of the drive unit must not be exceeded. The safe operation can only be ensured if used as specified.

Target audience of these installation instructions

These installation instructions are geared towards qualified persons trained in the handling of door systems. Expert knowledge, relevant skills and practical experience are what set apart qualified persons. They are capable of safely carrying out the tasks involving installation, maintenance and modernisation according to the instructions.

Safe operation

The safe operation of the product can only be ensured if it is used as specified. Follow the installation instructions. Observe all specifications, especially warnings, when installing the product in the overall system. GfA is not liable for damage resulting from non-observance of the installation instructions. The resulting overall system must be reassessed for its safety in accordance with applicable standards and directives (e.g. CE marking). These installation instructions refer only to a part of the overall system and are not sufficient as the sole instructions for the overall system. The installer of the system must prepare the instructions for the overall system. We recommend entering the danger area of the system only when the drive unit is at a standstill.



Warning - Failure to follow these installation instructions may result in severe injury or death.

- Please read these instructions before using the product.
- Keep these instructions handy.
- Include these instructions when passing on the product to third parties.



Warning - Danger from improper use of the product!

- Do not let children operate the product unsupervised or use as a toy.



Warning - Danger to life from incorrect installation!

Work carried out improperly may result in death or severe injury from electrical current or falling parts.

- Allow only competent people to carry out the work.
- Disconnect all cables from the power supply.
- Observe valid regulations and standards.
- Use suitable tools.



Warning! Danger to life from falling objects if the drive unit is subjected to impermissible forces.

Inadmissible forces (examples: collision with a forklift, dropping the drive unit, tearing or pulling on the motor) lead to damage to the drive unit. There is a risk of severe injury or death from falling objects.

- Prevent impermissible forces from acting on the drive unit,
- Check the drive unit for damage if impermissible forces have acted on it. Look even for minor damage. Lock the door during the inspection.
- Contact the service department if you have difficulty assessing the damage.

2 Technical data

Designation		Unit
Output speed	60	rpm
Output torque	170 (150) ¹⁾	Nm
Output / hollow shaft	25,40	mm
Series	SG 63F	-
Limit switch range (maximum revolutions of the output / hollow shaft)	20	-
Supply voltage	1N~ 230	V
Operating current	6,60	A
Operating frequency	50/60	Hz
Power factor cos φ	0,47	-
Safety circuit	24	V
Degree of protection	IP 65	-
Temperature range	+5 / +40 (+60) ²⁾	°C
Operating sound pressure level	< 70	dB(A)
Output speed OPEN	8-60	min ⁻¹
Output speed CLOSE	8-35	min ⁻¹
Output speed CLOSE > 2,5 m	8-35	min ⁻¹
Cycles per hour	17 (16,6) ¹⁾	h ⁻¹
Max. holding torque	170	Nm
Locking torque	420	Nm
Safety brake (testing centre / approval number)	14-003612-PR02	-
Braking torque	5	Nm
Braking voltage	103	V DC
Rectifier type	FU	-
Manual force emergency manual operation	127	N

1) Specification in () according to EN 60335-2-103.

2) When using a temperature range of +40°...+60°C use half of maximum cycles per hour.

3 Special version with vent screw

This drive unit is equipped with a vent screw.

- The escape of small amounts of oil in the vent screw is not problematic.

Position

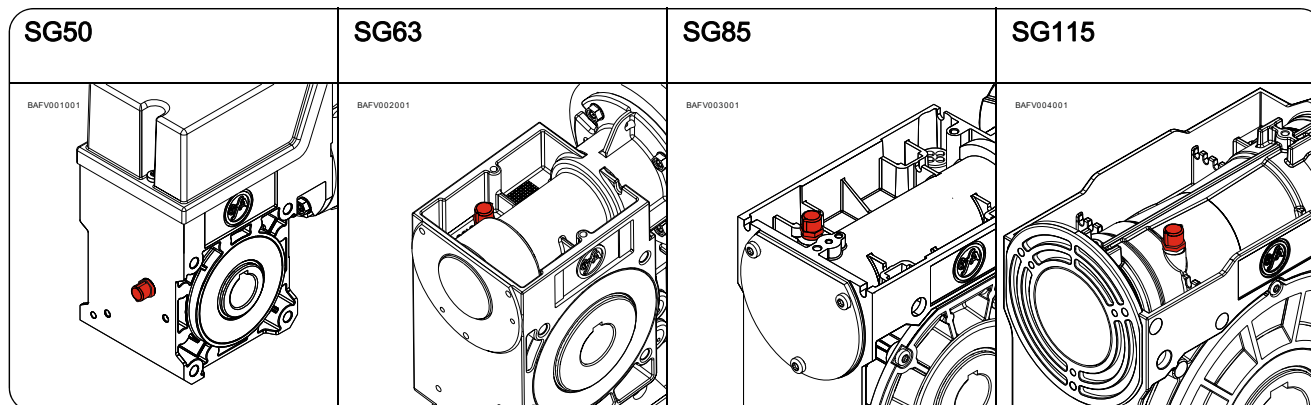

On-site installation (air transport)

Drive units shipped by air transport are equipped with a screw plug (①) instead of a vent screw. The vent screw (②) is enclosed separately with the drive units.

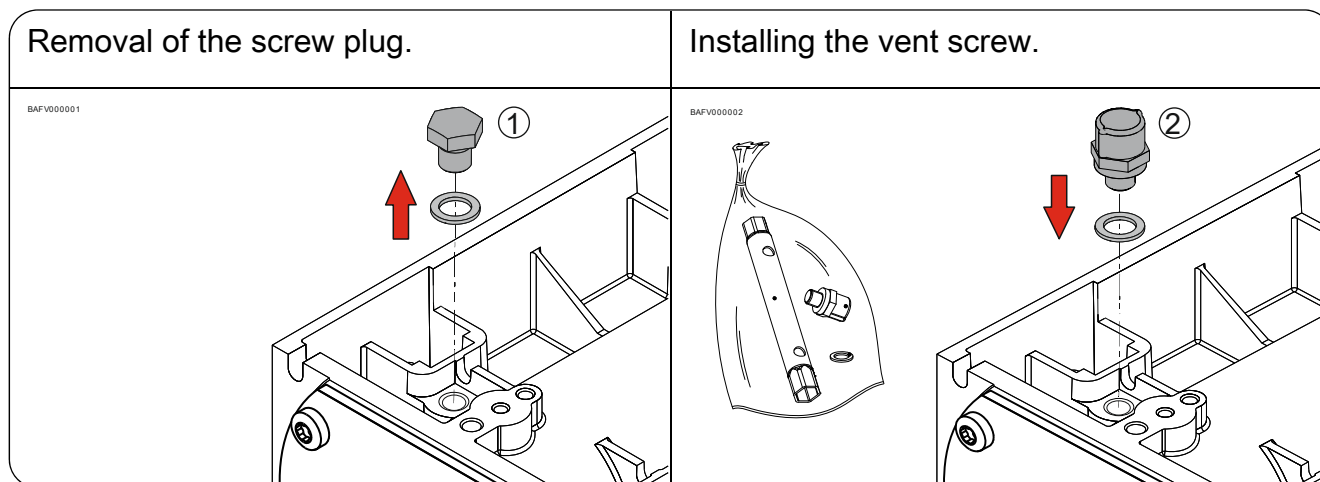

Caution - Component damage can result!

- ▶ To prevent the leakage of oil, the permissible mounting position of the drive unit must be observed.

4 Integrated safety brake

A safety brake is integrated into the gearbox of this ELEKTROMATEN. The safety brake protects against the door dropping due to breakage or wear of the gear teeth. The safety brake works regardless of the mounting position, speed and rotating direction. It is maintenance-free. The specification of the locking torque and the approval number of the safety brake are available in the technical data of these instructions.



Warning - Danger of the door dropping!

If you need to apply more than the permissible force of 390N (according to DIN EN 12604/DIN EN 12453) to move the door by emergency manual operation, this indicates a stalling on the drive unit or door. Releasing the stalling may cause the door to drop.

- Adopt a secure position.
- For drive units with brake, the emergency manual operation must be carried out against the closed brake.

5 Mechanical installation

Prerequisites

The permissible loads on walls, fastenings, mountings and transmission elements must not be exceeded, even for maximum holding torques or locking torques (► refer to technical data).

Connection elements

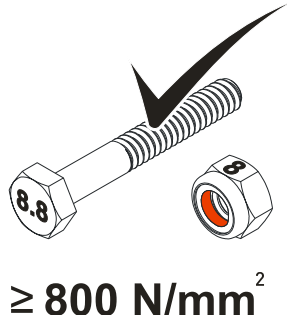
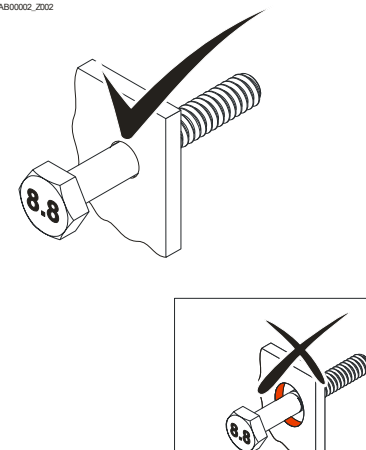
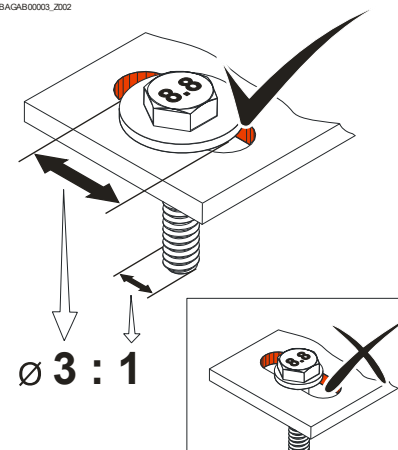
<ul style="list-style-type: none"> ► Self-locking connection elements with a minimum strength of 800 N/mm² (8.8) must be used. 	<ul style="list-style-type: none"> ► Utilize the hole diameter to the full. 	<ul style="list-style-type: none"> ► Use adequately dimensioned washers for elongated holes.
<p>BAGAB00001_Z002</p>  <p>≥ 800 N/mm²</p>	<p>BAGAB00002_Z002</p> 	<p>BAGAB00003_Z002</p>  <p>Ø 3 : 1</p>

Permissible mounting positions

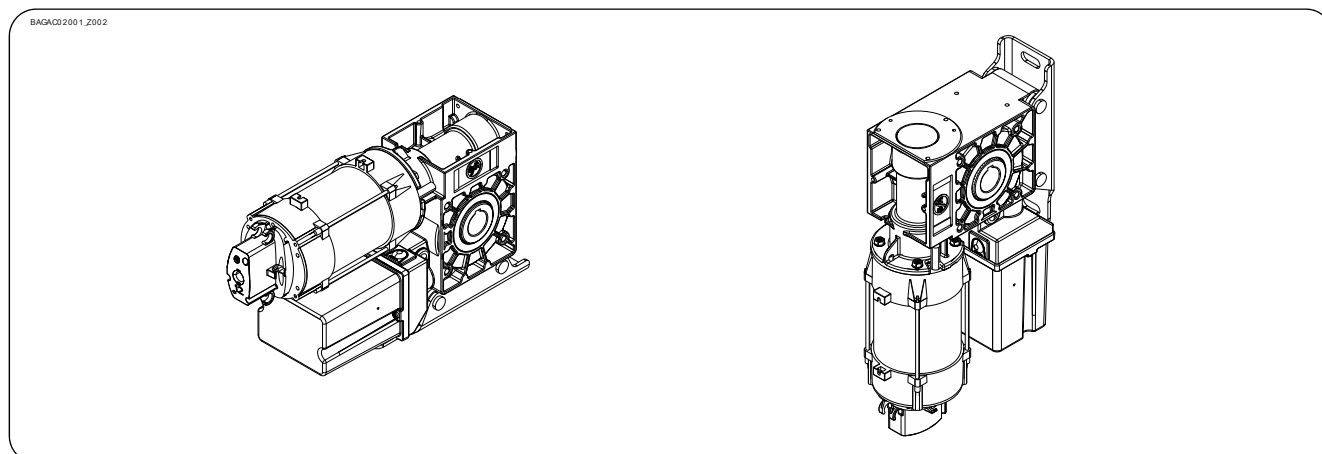

Mounting (possible versions A + B)

Eight threads are available for version A.

Three elongated holes are provided for version B.

- ▶ Use at least 2 of these (1) for mounting. Always use elongated hole 1.

A key is used to connect to the door shaft.

- ▶ Use a key that is at least as long as the hollow shaft (2).

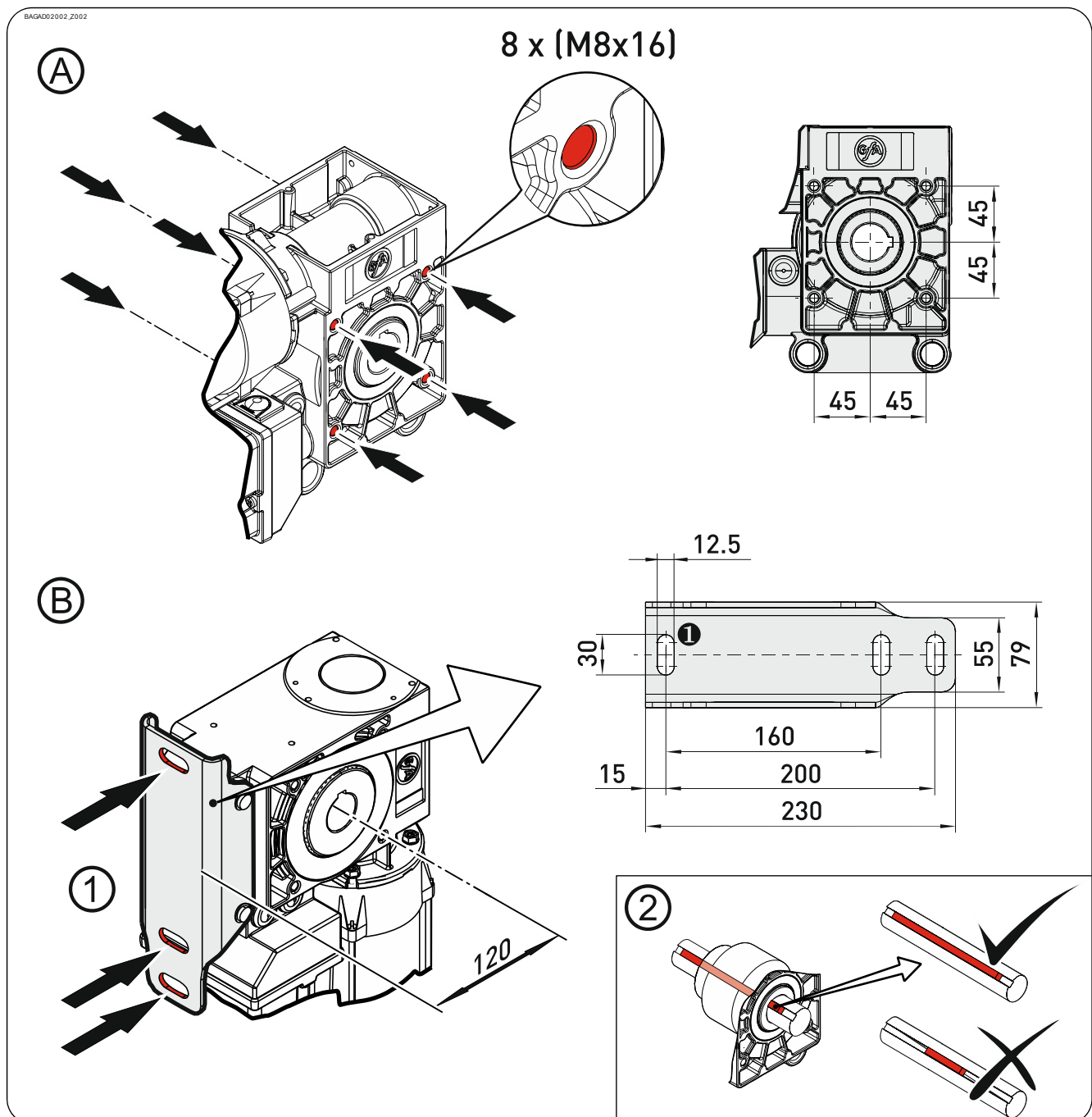

Installation

The descriptions below apply to general door specifications. The specifications of the door manufacturer must also be observed during installation.



Warning - Potential injury or danger to life!

- During installation, be sure to use a lifting device that has a sufficient load-carrying capacity.

Versions (A) + (B):

- ▶ Thoroughly grease the door shaft.

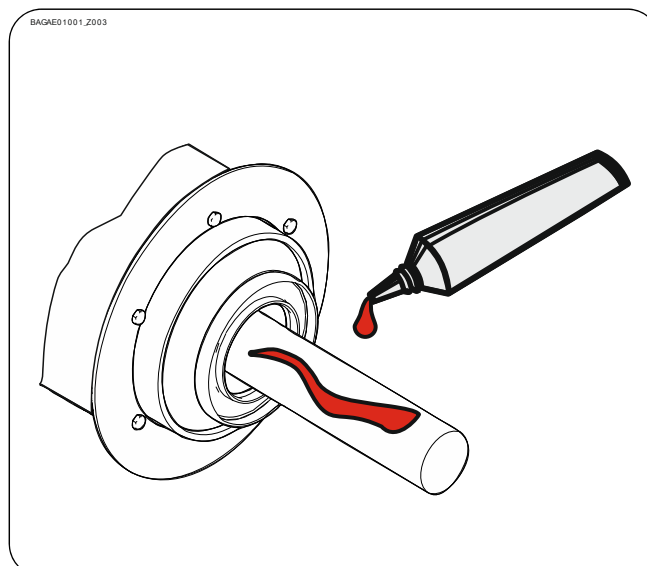

Versions (A) + (B):

- ▶ Mount the keys. Possible version (C) or (D).

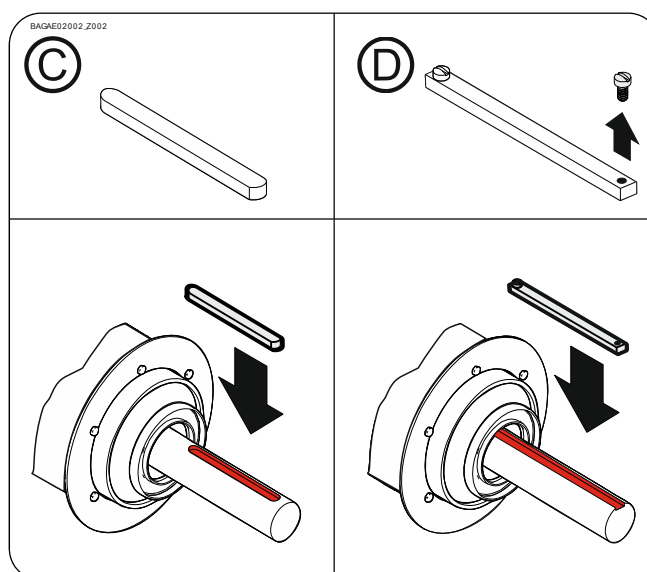

Version ①:

- ▶ Attach the drive unit.

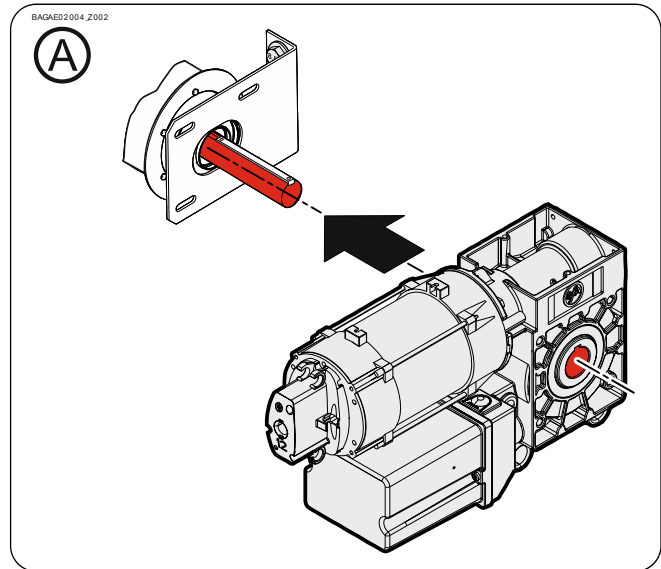

Version ②:

- ▶ Tighten all connection elements (M8) to 25 Nm. Install all other connection elements according to the specifications of the door manufacturer.

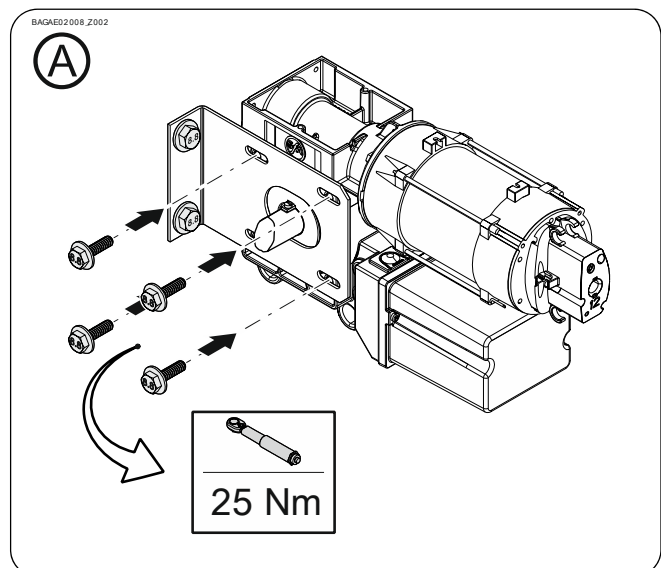

Version ③:

- ▶ Attach the drive unit.

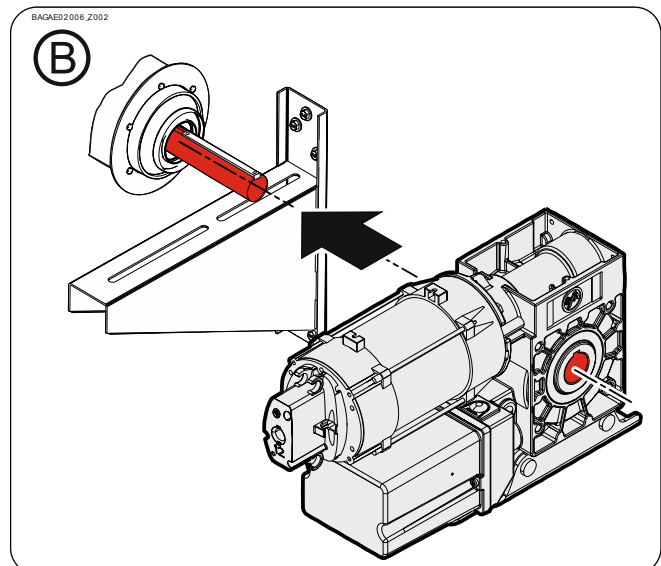

Version ②:

- ▶ Tighten all connection elements (M12) to 75 Nm. Install all other connection elements according to the specifications of the door manufacturer.

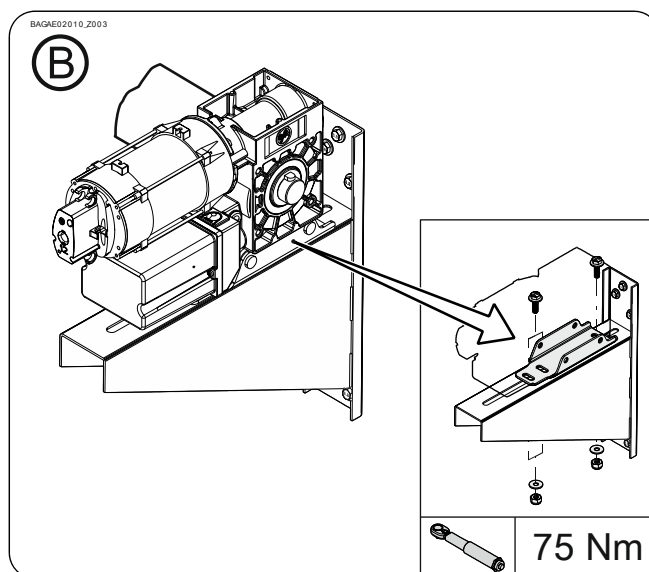

Versions ① + ②:

- ▶ Secure the keys (version ② only).

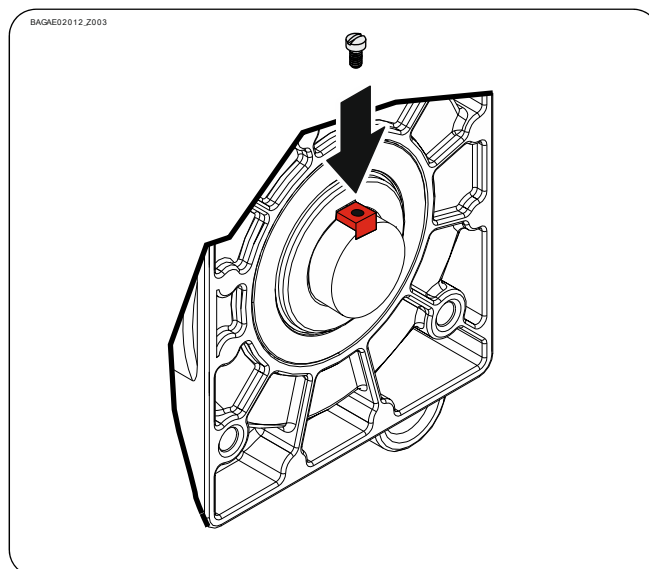

6 Electrical installation



Warning - Danger to life from electric current!

- Switch the mains OFF and check that the cables are de-energised
- Observe the applicable regulations and standards
- Make a proper electrical connection
- Use suitable tools

Performing electrical installation

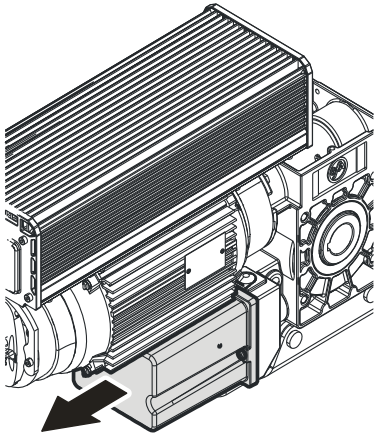
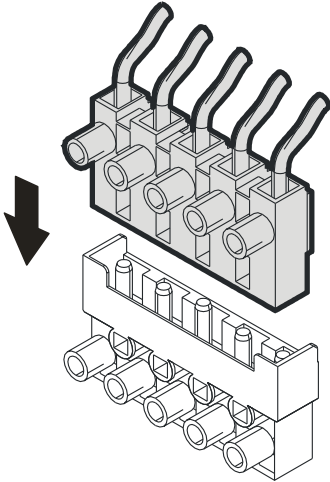
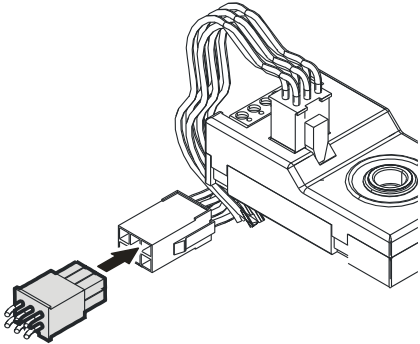
Remove the cover.	Insert the motor plug.	Insert the limit switch plug.
<p><small>BPHED01_2001</small></p> 	<p><small>BPHED01_2001</small></p> 	<p><small>BPHED01_2001</small></p> 

Completing the electrical installation

Mount the cable entries and/or cable glands.

7 Limit switch setting

The setting of the final limit positions OPEN and CLOSE is described in the instructions for the door control.

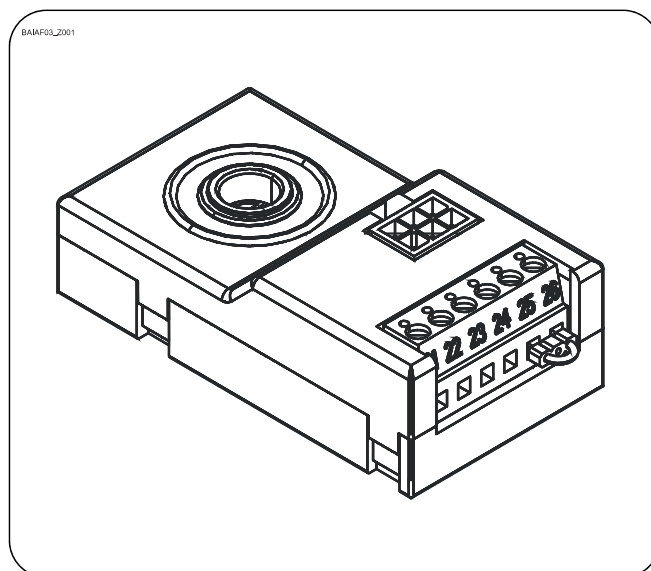

The door control must meet Performance Level c!

Use only door controls that evaluate the limit switch according to EN 12543 and meet Performance Level c.

8 Motor connection

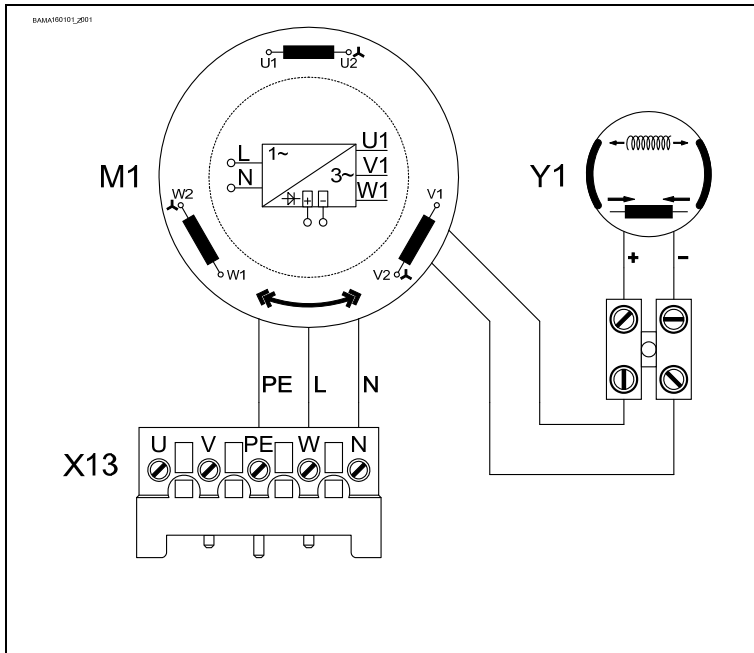

M1	Motor
X13	Motor plug
Y1	Spring applied brake

9 Limit switch connection

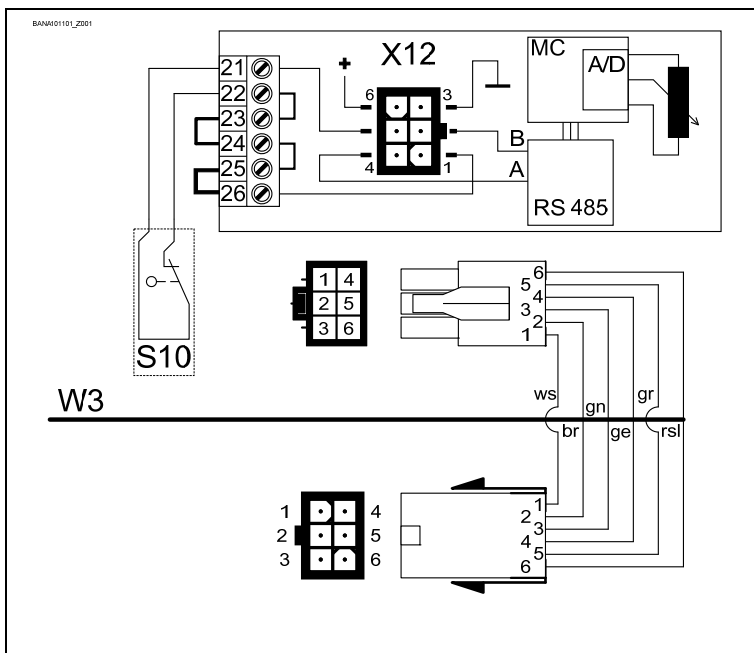

S10	Emergency manual operation
X12	DES connection
1	Safety circuit
2	Channel B (RS485)
3	Ground
4	Channel A (RS485)
5	Safety circuit
6	Supply voltage
W3	Connection cable frequency inverter (FI)

10 Emergency manual operation (hand chain operator)

Emergency manual operation is designed for opening or closing the door without power supply. Its activation interrupts the control voltage. Electrical operation is no longer possible.



Warning – Injuries due to incorrect operation!

- Switch off voltage.
- Adopt a secure position.
- For drive units with brake, the emergency manual operation must be carried out against the closed brake.



Warning - Danger of the door dropping!

If you need to apply more than the permissible force of 390N (according to DIN EN 12604/DIN EN 12453) to move the door by emergency manual operation, this indicates a stalling on the drive unit or door. Releasing the stalling may cause the door to drop.

- Adopt a secure position.
- For drive units with brake, the emergency manual operation must be carried out against the closed brake.



Caution – Damage to components!

- Do not move the door beyond the final limit positions.

Switch on by pulling the red handle. Open or close by pulling the chain. Switch off by pulling the green handle.

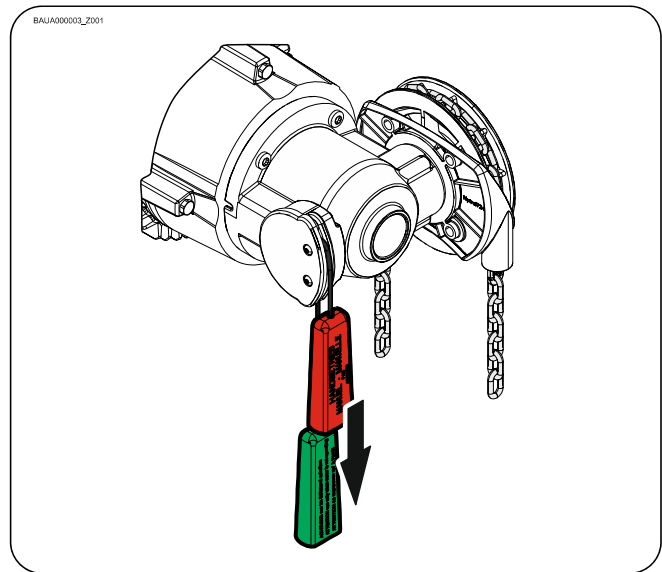

11 Completion of commissioning / testing

Check the following components and after that, mount all covers.

Gearbox

Check drive unit for oil loss (a few drops are not critical). Protect output shaft permanently against corrosion.

Safety brake in the gearbox

The safety brake requires no maintenance or inspection.



Warning – Danger of the door dropping

In the case of a gearbox damage, the internal safety brake is triggered to prevent the door from dropping. The gearbox stalls.

Releasing the stalling may cause the door to drop!

- Block the door for pedestrians and vehicles.
- Do not release the stalling. Do not use the emergency manual operation.
- Secure the door against dropping. Please observe the specifications of the door manufacturer.
- The drive unit needs replacement. Please observe the specifications of the door manufacturer.

Mounting

Check all mounting elements (consoles, torque brackets, screws, retaining rings etc.) for tightness and impeccable condition.

Electric wiring

Check connection cables and cables for damage or pinches. Check screw and plug connections for correct seating and electrical contact.

Emergency manual operation

Function to be checked in a de-energised state. Carry out functional test only between final limit positions.

Limit switches

Check the final limit positions by opening and closing the door completely. The safety zone must not be reached.

Brake



Warning – Injury or danger to life possible!

- Carry out brake test. Overrun depends on the door and its equipment. The manufacturer's specifications must be observed.
- The brake release for doors without counter-balancing may only be used in the CLOSE final limit position.



Warning – Injury or danger to life possible!

Service life of the brake - replacement of the entire brake in the case of:

- Operation with mains supply after 250,000 door cycles
- Operation with frequency inverter after 1,000,000 door cycles

Degree of protection IP65i must be used in environments that may change the friction coefficient of the brake pad (atmospheres with oil, solvents, cleaning agents, etc.).

Entire drive unit



Note!

- Have the drive checked annually by a specialist.
- Shorter inspection interval for frequently used doors.
- Observe the applicable regulations and standards.

12 Disposal

Dispose of packaging

Dispose of the packaging material properly according to the local legal regulations or recycle it.

Dispose of old devices

Dispose of old devices properly according to local legal regulations. Return old devices to the return and collection systems available. You can also return GfA products free of charge. Please apply enough postage to the package and mark it as "old devices".



Notice- Environmental damage!

The gearbox contains oil.

- Ensure proper disposal according to local legal regulations.

Declaration of incorporation

within the meaning of Machinery Directive 2006/42/EC
for partly completed machinery, Appendix II Part B



Declaration of conformity

within the meaning of EMC Directive 2014/30/EU
within the meaning of RoHS Directive 2011/65/EU

GfA ELEKTROMATEN GmbH & Co. KG
Wiesenstraße 81 · 40549 Düsseldorf
Germany

We,

GfA ELEKTROMATEN GmbH & Co. KG

declare under our sole responsibility that the following product complies with the above directives and is only intended for installation in a door system.

Drive unit

SI 17.60 FU-25,40

Part no.: 10003900 10014

We undertake to transmit in response to a reasoned request by the appropriate regulatory authorities the special documents on the partly completed machinery.

This product must only be put into operation when it has been determined that the complete machine/system in which it has been installed complies with the provisions of the above-mentioned directives.

Authorised representative to compile the technical documents is the undersigned.

Düsseldorf, 10.08.2018

Stephan Kleine
CEO

Signature

The following requirements from Appendix I of the Machinery Directive 2006/42/EC are met:

1.1.2, 1.1.3, 1.1.5, 1.2.2, 1.2.3, 1.2.6, 1.3.2, 1.3.3, 1.3.9, 1.5.1, 1.5.2, 1.5.4, 1.5.6, 1.5.7, 1.5.8, 1.5.9, 1.5.10, 1.5.11, 1.5.13, 1.6.1, 1.6.2, 1.6.4, 1.7.2, 1.7.3, 1.7.4.3.

Standards applied:

EN 12453:2001

Industrial, commercial and garage doors and gates - Safety in use of power operated doors - Requirements

EN 12604:2017

Industrial, commercial and garage doors and gates - Mechanical aspects - Requirements

EN 60335-1:2012

Household and similar electrical appliances - Safety - Part 1: General requirements

EN 61000-6-2:2005

Electromagnetic compatibility (EMC) Part 6-2
Generic standards – Immunity standard for industrial environments

EN 61000-6-3:2007

Electromagnetic compatibility (EMC) Part 6-3
Generic standards – Emission standard for residential, commercial and light-industrial environments

