

Typ A

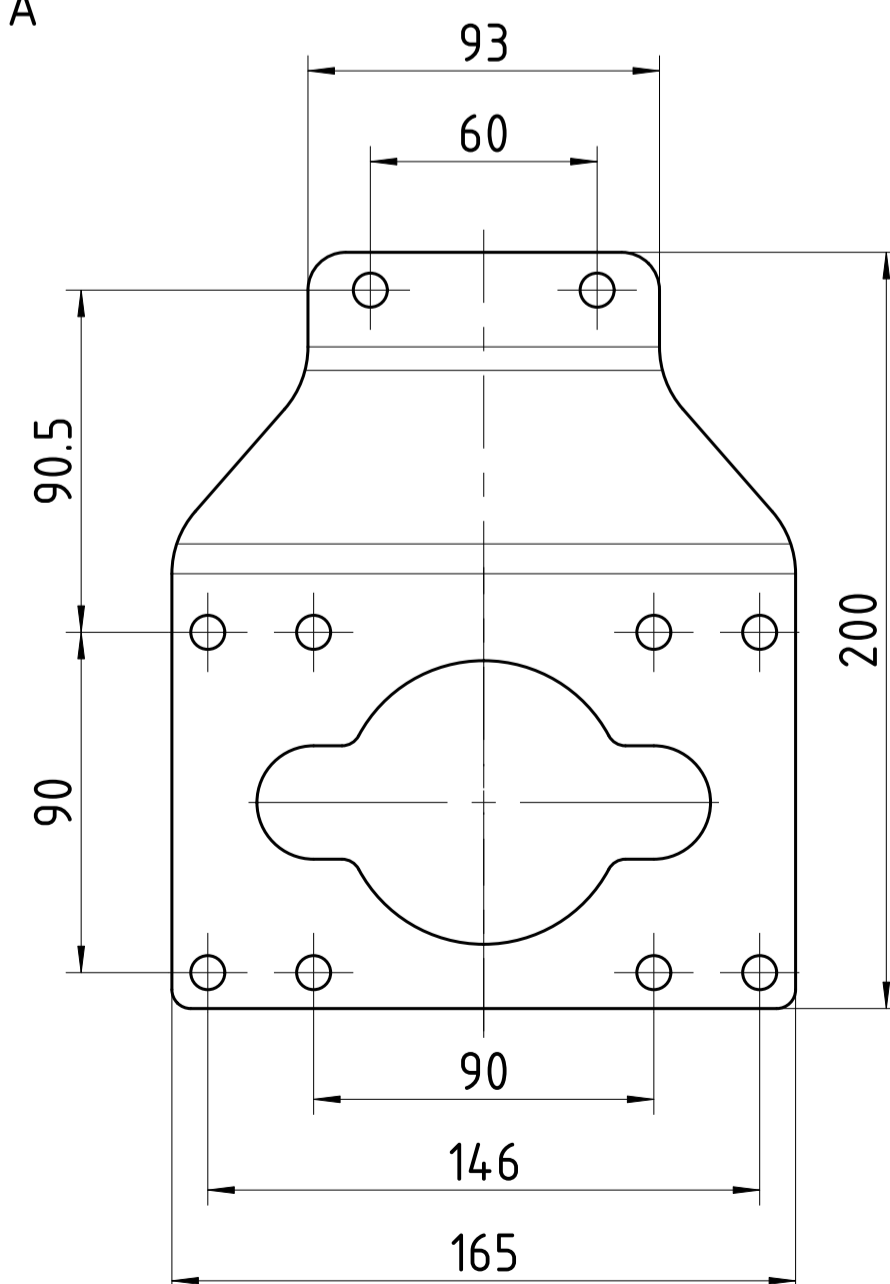

Typ B

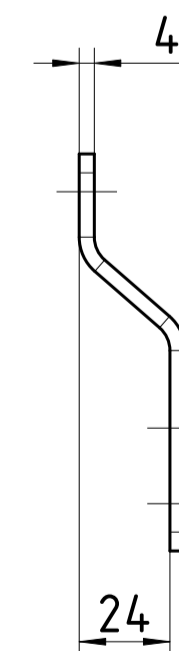
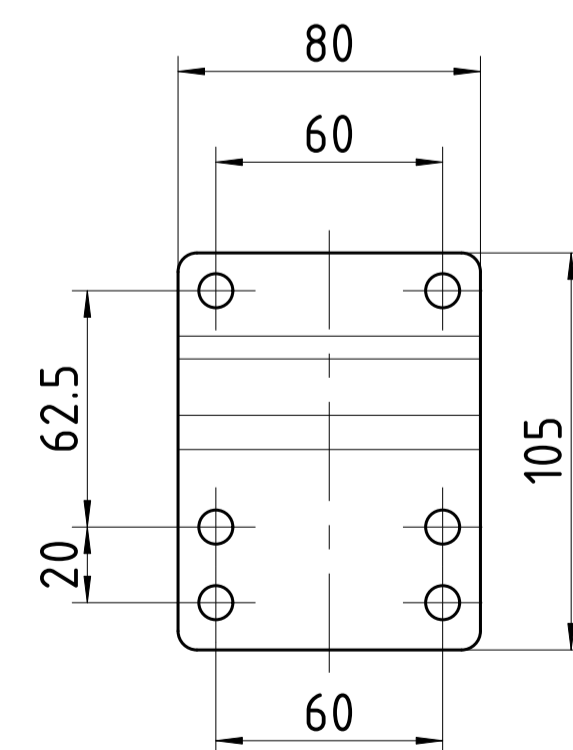
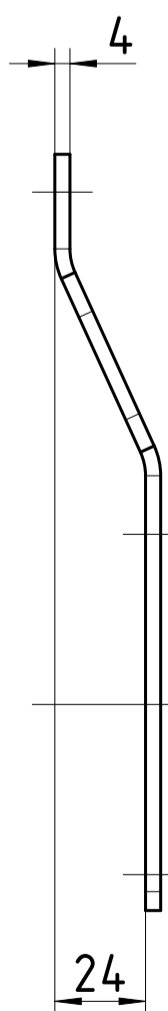

Art.-Nr.	Bezeichnung
10004398	SE 8.60-25,40 FU

Ind./Alt.	Dokumentenstatus	Ausgabedatum	Zulässige Abweichung	Exekution nach	Maßstab	Format	Gewicht
C.1	Freigegeben	26.09.2019			1:2	DIN A1	
			Datum	Name	Werkstoff:		Klassifikation
			Geprüft		div.		1 PP 446 09
			Genehmigt		Benennung		
C	ohne	26.09.2019	Bjick	GFA ELEKTROMATEN Wiesenstraße 81 40549 Düsseldorf Germany			Einbauzeichnung SG40 SE 8.60 FU/ SE 8.20/ SE 5.18WS
b	ohne	05.08.2019	Bjick				Art.- / Zeichnungsnummer
a	ohne	31.08.2011	Bjick	Verwendungsbereich SG40			50002000
Ind	AM	Datum	Ersteller				Blatt
							1/1