



Installation instructions

Safety brake

FG 120-50

Type: 10002272 00001

-en-

Version: 25.11.2021



GfA ELEKTROMATEN GmbH & Co. KG
Wiesenstraße 81 • 40549 Düsseldorf

🌐 www.gfa-elektromaten.de
✉ info@gfa-elektromaten.de

Table of contents

1	General safety information	4
2	Technical data	5
3	Function.....	6
4	Mechanical installation	7
5	Electrical installation	11
6	Safety brake activation.....	13
7	Repair	14
8	Completion of initial operation / inspection	15
9	Declaration of conformity	16

Symbols



Warning - Potential injury or danger to life!



Warning - Danger to life from electric current!



Note - Important information!



Requirement - Required action!

Schematic representations are based on product examples. Deviations from delivered products are possible.



1 General safety information

Specified normal use

The safety brake is intended for loads which must be secured against falling down. The safety brake is mounted directly onto the shaft. The safety brake is activated automatically in the case of trapping. The function depends on speed and rotary direction. The safe operation is only guaranteed with specified normal use. No liability for damage caused by other applications or non-observance of the information in the manual. Modifications are only permitted with the agreement of the manufacturer. Otherwise the Manufacturer's Declaration shall be rendered null and void.

Safety information

Installation and initial operation tasks are to be performed by skilled personnel only. Only trained electrical craftsmen are permitted to work on electrical equipment. They must assess the tasks assigned to them, recognise potential danger zones and be able to take appropriate safety measures. Installation work is only to be carried out with the supply off. Observe the applicable regulations and standards.

Coverings and protective devices

Do not operate unless corresponding coverings and protective devices are installed. Ensure that cable glands are correctly tightened.

Spare parts

Only use original spare parts.

2 Technical data

Series	FG 120-50	
Max. torque	1200	Nm
Output / hollow shaft (Ø)	50	mm
Locking torque	3530	Nm
Safety brake (approval number)	TorFV 3/009	
Maximum operating speed OPEN / CLOSE	45 / 24	rpm
Admissible bearing load F_{max}	6000	N
Keyway width	14	mm
Keyway height	53,8	mm
Protection class	IP 65	
Admissible temperature range	-20 / +60	°C

3 Function

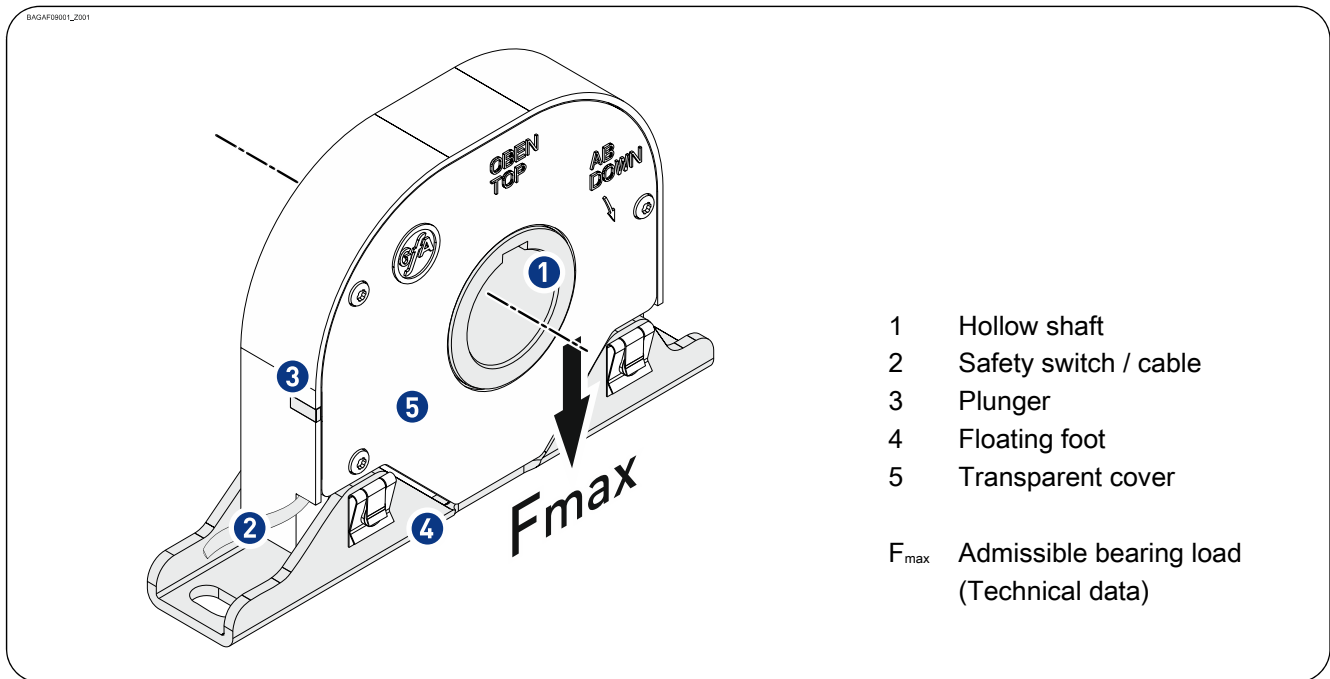

In normal operation, the safety brake functions similar to pedestal bearings. The safety brake is tripped as soon as the maximum operating speed in DOWN direction is exceeded. This results in the following reactions:

- The shaft is blocked in DOWN direction (1).
- The safety switch is actuated to interrupt the control current (2).
- Release is optically indicated by a red plunger (3).

Operating position:

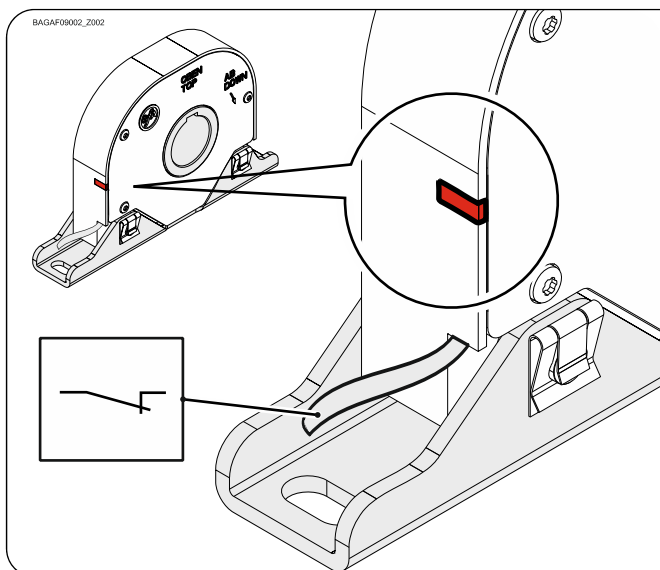

Braking position:

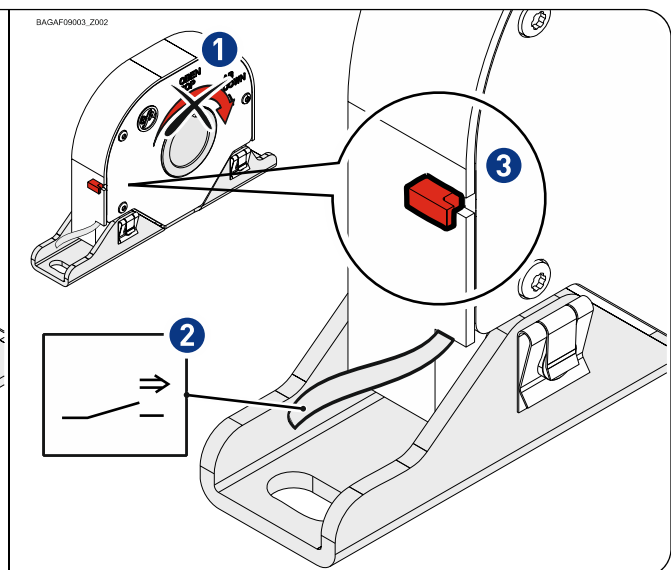

4 Mechanical installation

Requirements

The permissible loads on walls, mountings, connection and transmission elements must not be exceeded even for maximum locking torque (► observe technical data).

Connection elements:

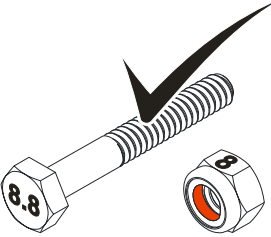
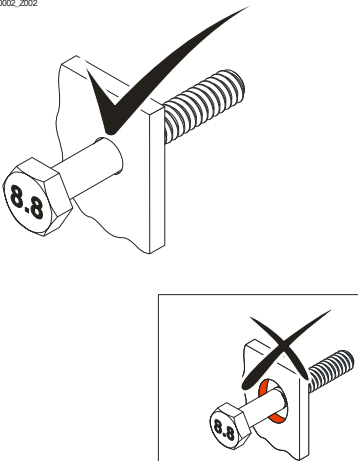
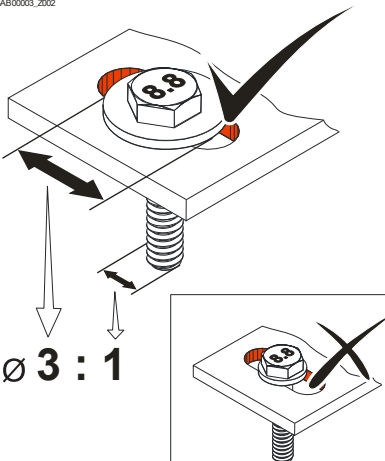
<ul style="list-style-type: none"> ► Use self-locking connection elements with a minimum strength of 800 N/mm² (8.8). 	<ul style="list-style-type: none"> ► Use a screw that precisely fits the hole. 	<ul style="list-style-type: none"> ► Use adequately dimensioned washers for elongated holes.
<p>BAGAB00001_Z002</p>  <p>≥ 800 N/mm²</p>	<p>BAGAB00002_Z002</p> 	<p>BAGAB00003_Z002</p>  <p>Ø 3 : 1</p>

Permissible mounting positions

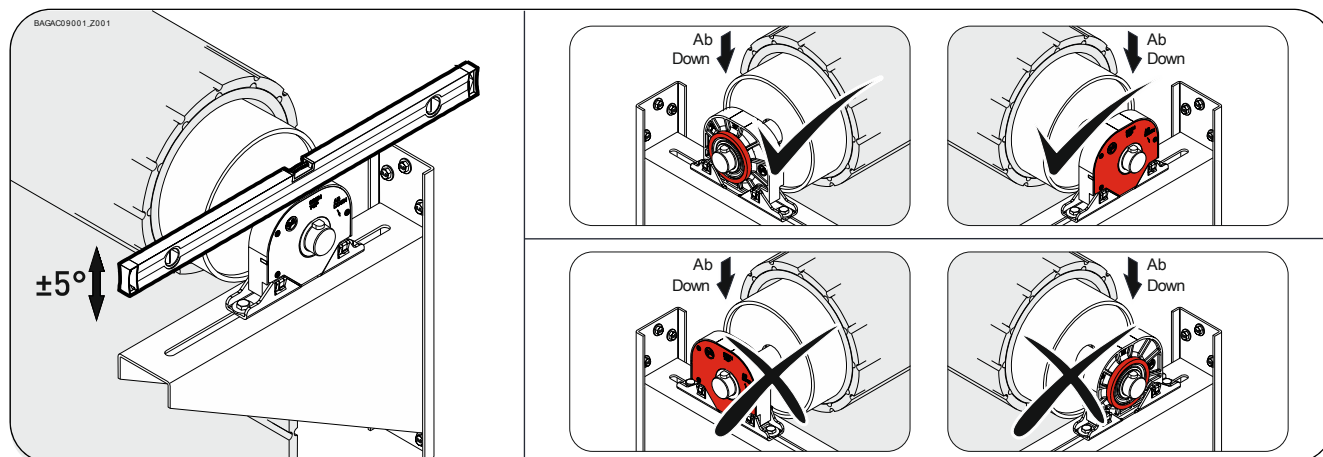

Mounting

2 elongated holes are provided for mounting.

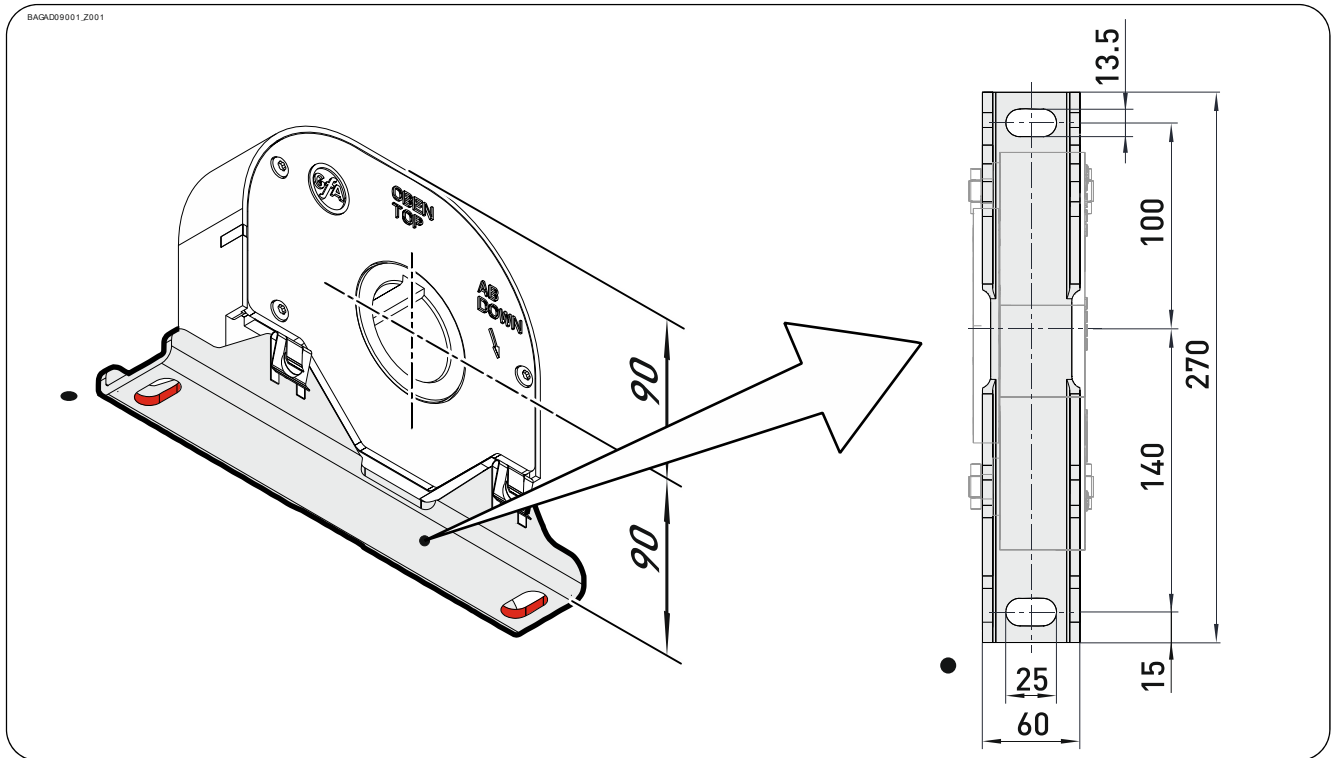

Installation

The following descriptions refer to a facility or door which is not further defined. The facility or door manufacturer's specifications must also be observed.



Warning – Injury or danger to life possible!

- Use a lifting device with sufficient load-carrying capacity for installation tasks.

- ▶ Completely grease the door shaft.

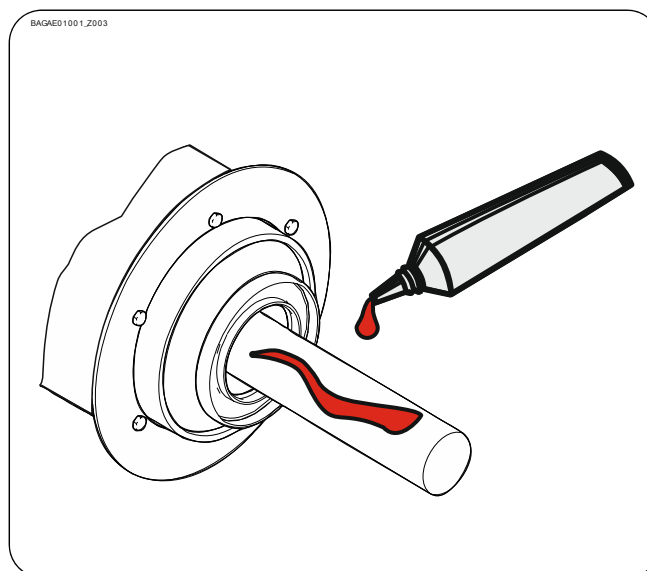

- ▶ Mount the key.

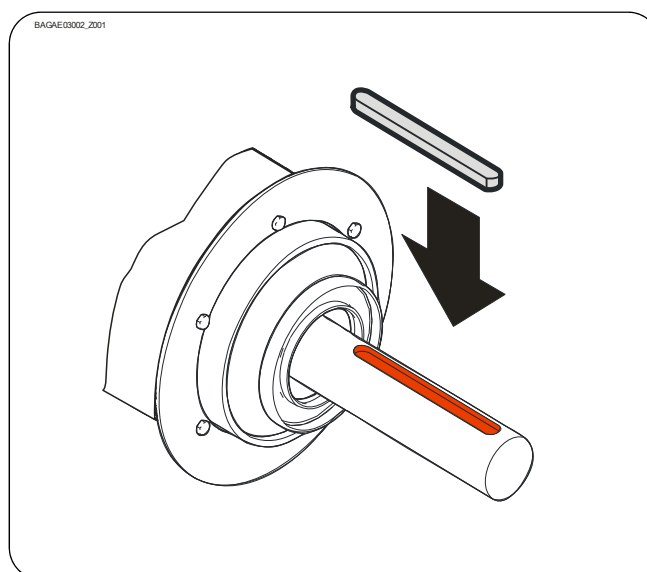

- ▶ Attach safety brake. Observe rotating direction.

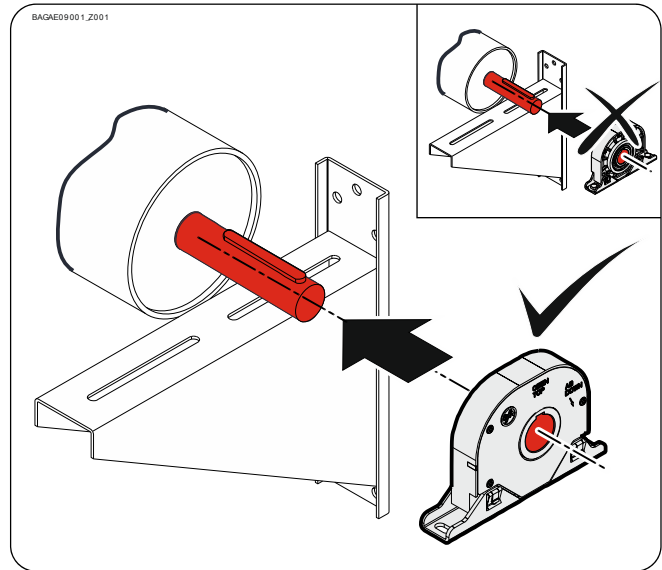

- ▶ Tighten all connection elements (M12) with a torque of 75 Nm. Install all further connection elements according to the specifications of the door or facility manufacturer.

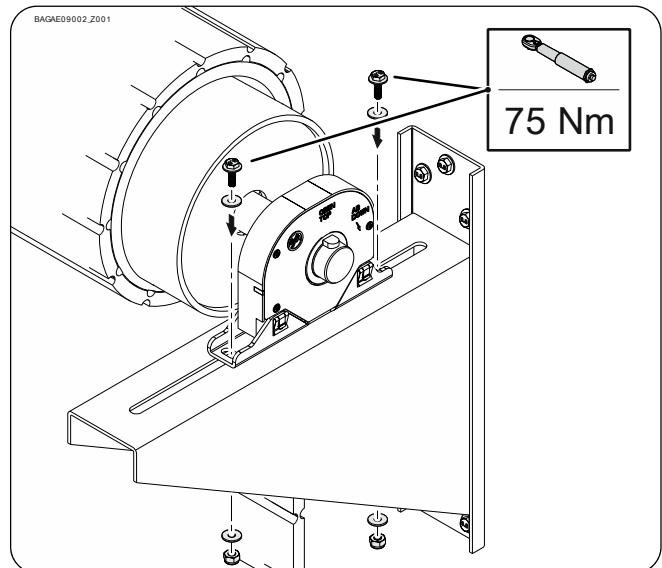

Note

If the safety brake has been tripped during installation, follow the procedure described under – *6 Safety brake activation* –.

5 Electrical installation



Warning – Danger to life from electrical shock!

- Disconnect the cables (mains OFF) and check that the supply is off
- Observe the applicable regulations and standards
- Ensure proper electrical connection
- Use suitable tools



Warning - Danger due to uncontrolled movement!

The connection cable of the safety brake must be protected against cross-faults. If a cross-fault occurs, the safety switch does not interrupt the control current. A movement of the door due to a movement command cannot then be ruled out.

- Ensure that the installed connection cable is protected.

Cross-fault: A cross-fault is a short circuit between two wires inside a cable.

Should the safety brake be activated, the safety switch will be activated to interrupt the control current of the drive unit (see –**Fehler! Verweisquelle konnte nicht gefunden werden.** *Function*–). Electrical operation is no longer possible.

Carrying out the electrical installation (drive unit: GfA-ELEKTROMATEN)

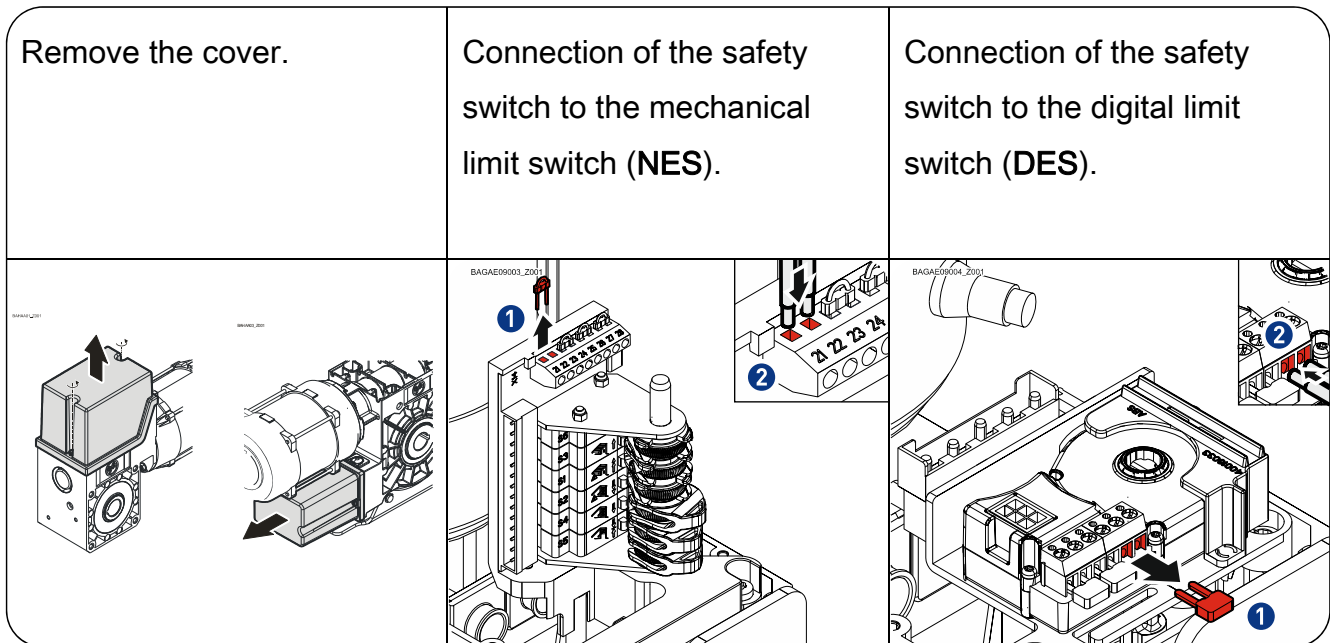

Carrying out the electrical installation (drive unit: alternative manufacturer)

Instructions on how to connect the safety switch can be found in the documents provided by the manufacturer of the drive unit or control system.

Completing the electrical installation

Install cable entries and/or cable glands.

6 Safety brake activation

The safety brake is tripped as soon as the maximum operating speed in DOWN direction is exceeded. This results in the following reactions:

- The shaft is blocked in DOWN direction (1).
- The safety switch is actuated to interrupt the control current (2).
- Release is optically indicated by a red plunger (3).

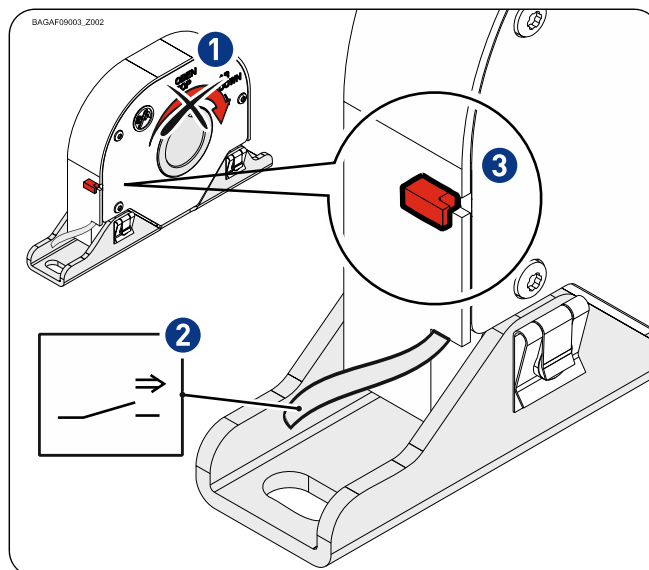

Warning!

- De-energise the facility and secure against unintended switching-on.
- Secure door/load against falling.
- Rectify the cause of tripping (drive unit, chain, etc.).

Any time the safety brake has been tripped, it must be disassembled and checked. If the control pointer (1) is damaged, the safety brake must be replaced.

Control pointer (1).	Control pointer broken. ⇒ A Replace safety brake!	Control pointer damaged. ⇒ B Replace safety brake!	Control pointer not damaged. ⇒ C Repair safety brake.

7 Repair

If the control pointer is not damaged (see – 6 Safety brake activation – ©), the safety brake can be repaired.

- ▶ Rotate hollow shaft in OPEN direction by approx. 90°.

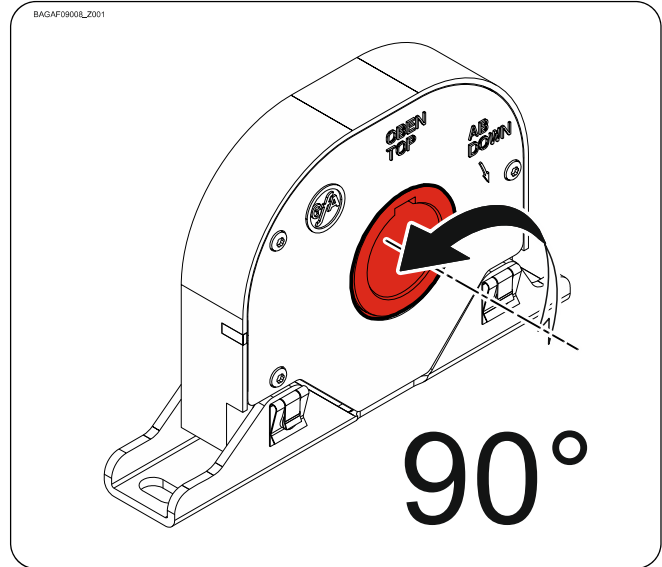

- ▶ Press the red plunger back into the housing.
- ▶ The safety brake is ready for operation again.

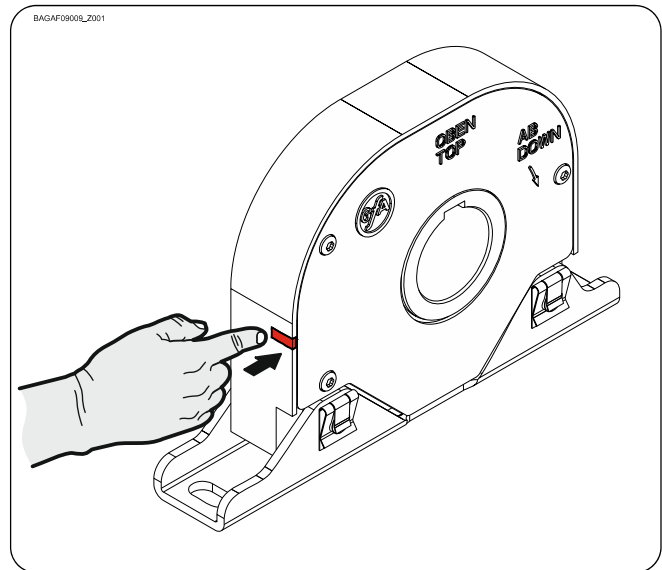

8 Completion of initial operation / inspection

Check the following components and after that, mount all covers.

Mounting

Check all mounting elements (consoles, screws, retaining rings etc.) for tightness and impeccable condition.

Electric wiring

Check connection cables and cables for damage or pinches.



Warning – Injury or danger to life possible!

- Do not activate the safety brake without having connected the safety switch!

Check screw and plug connections for correct seating and electrical contact.

Mounting position

On the basis of the OBEN/TOP and AB/DOWN markings and by checking.

Maintenance/inspection

The safety brake requires no maintenance.

The safety brake is type-approved. Checking for correct functioning is not required and inadmissible once the safety brake is installed.

Entire safety brake



Note!

- Have a specialist check the safety brake once a year.
- Shorter inspection interval for frequently used equipment or doors.
- Observe the applicable regulations and standards

Declaration of conformity

within the meaning of Machinery Directive 2006/42/EC
within the meaning of RoHS Directive 2011/65/EU



GfA ELEKTROMATEN GmbH & Co. KG
Wiesenstraße 81 · 40549 Düsseldorf
Germany

We,
GfA ELEKTROMATEN GmbH & Co. KG
declare under our sole responsibility that the
following product complies with the above
directives and is only intended for installation in a
door system.

Safety brake

FG 120-50

Part no.: 10002272 00001

Authorised representative to compile the
technical documents is the undersigned.

Düsseldorf, 10.08.2018

Stephan Kleine

CEO

Signature

Standards applied:

EN 12604:2017

Industrial, commercial and garage doors and
gates - Mechanical aspects - Requirements

EN 12605:2000

Industrial, commercial and garage doors and
gates - Mechanical aspects - Test methods

EN 60204-1:2006

Safety of machinery - Electrical equipment of
machines - Part 1: General requirements