

ULTRA POWER

UP100AC *Plus*

Multi Charger
Built-in Power Supply

INSTRUCTION MANUAL

**100W
10A**



UP100AC Plus: 100W 10A AC/DC Charger

TABLE OF CONTENTS

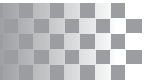

Warning and Safety Notes.....	2
Introduction.....	4
Specification.....	4
Special Features.....	6
Warning and Safety Notes.....	8
Lithium Battery Connection Diagram.....	10
Program Flow Chart.....	12
Lithium Battery(LiPo/LiFe/Lilon/LiHV)Program.....	13
Charging Lithium Battery at Balance Mode.....	13
Charging of Lithium Battery.....	14
'Fast' Charging of Lithium Battery.....	15
'Storage' Control of Lithium Battery.....	16
Discharging Lithium Battery.....	17
Pb Battery Program.....	18
Charging of Pb Battery.....	18
Discharging of Pb Battery.....	18
NiMH/NiCD Battery Program.....	19
Charging of NiMH/NiCD Battery.....	19
Charging NiMH/NiCD Battery in the Auto Charge Mode.....	19
Charging NiMH/NiCD Battery in re-peak Charge Mode.....	20
Discharging of NiMH/NiCD Battery.....	20
Charge/Discharge & Discharge/Charge Cycle of NiMH/NiCD Battery....	21
Battery Memory Set.....	22
Lithium Battery Meter.....	24
System Set up.....	25
Various Information During the Process.....	27
Warning and Error Message.....	28
Warranty and Service.....	29

WARNING AND SAFETY NOTE

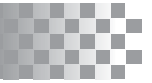

These warnings and safety notes are particularly important. Please follow the instructions for maximum safety; otherwise the charger and the battery can be damaged or at worst it can cause a fire. Also read the chapter before you begin.

- ❗ Never leave the charger unsupervised when it is connected to its power supply. If any malfunction is found, **TERMINATE THE PROCESS IMMEDIATELY** and refer to the operation manual.
- ❗ Keep the charger well away from dust, damp, rain, heat, direct sunshine and vibration. Never drop it.
- ❗ The allowable DC input voltage is 11-18V DC.
- ❗ The allowable AC input voltage is 100-240V AC.
- ❗ This charger and the battery should be put on a heat-resistant, non-flammable and non-conductive surface. Never place them on a car seat, carpet or similar surface. Keep all flammable volatile materials away from the operating area.
- ❗ Make sure you know the specifications of the battery to be charged or discharged to ensure it meets the requirements of this charger. If the program is set up incorrectly, the battery and charger may be damaged. Fire or explosion can occur due to overcharging. This warranty is not valid for any damage or subsequent damage arising as a result of a misuse or failure to observe the procedures outlined in this manual.
- ❗ To avoid short circuiting between the charge lead, always connect the charge cable to the charger first, then connect the battery. Reverse the sequence when disconnecting.
- ❗ Never attempt to charge or discharge the following types of batteries:
 - A battery pack which consists of different types of cells (including different manufacturers)
 - A battery that is already fully charged or just slightly discharged
 - Non-rechargeable batteries (pose an explosion hazard)
 - A faulty or damaged battery
 - A battery fitted with an integral charge circuit or a protection circuit.

WARNING AND SAFETY NOTE

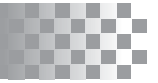

- Batteries installed in a device or which are electrically linked to other components
- Batteries that are not expressly stated by the manufacturer to be suitable for the currents the charger delivers during the charge process
- ❗ **Please bear in mind the following points before commencing charging:**
 - Did you select the appropriate program suitable for the type of battery you are charging?
 - Did you set up appropriate current for charging or discharging?
 - Have you checked the battery voltage? Lithium battery packs can be wired in parallel and in series, i.e. a 2-cell pack can be 3.7V (in parallel) or 7.4V (in series).
 - Have you checked that all connections are firm and secure? Make sure there are no intermittent contacts at any point in the circuit.

Standard Battery Parameters

	LiPo	Lilon	LiFe	LiHV	NiCd	MiMH	Pb
Nominal Voltage	3.7V/cell	3.6V/cell	3.3V/cell	3.7V/cell	1.2V/cell	1.2V/cell	2.0V/cell
Max Charge Voltage	4.2V/cell	4.1V/cell	3.6V/cell	4.35V/cell	1.5V/cell	1.5V/cell	2.46V/cell
Storage Voltage	3.8V/cell	3.7V/cell	3.3V/cell	3.85V/cell	n/a	n/a	n/a
Allowable Fast Charge	$\cong 1C$	$\cong 1C$	$\cong 4C$	$\cong 1C$	1C-2C	1C-2C	$\cong 0.4C$
Min. Discharge Voltage	3.0-3.3V/cell	2.9-3.2V/cell	2.6-2.9V/cell	3.1-3.4V/cell	0.1-1.1V/cell	0.1-1.1V/cell	1.8V/cell

Be very careful to choose the correct voltage for different types of battery otherwise you may cause damage to the batteries. Incorrect settings could cause the cells to fire or explode.

INTRODUCTION

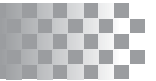

Thank you for purchasing UP100AC Plus charger by Ultra Power. This product is a rapid charger with a high performance microprocessor and specialized operating software. Please read this entire instruction manual completely and attentively before using this product, as it covers a wide range of information on operation and safety.

UP100AC Plus Specification	
Input voltage	AC 100-240V, DC 11.0-18.0V
Charge Power	Max. 100W
Discharge Power	Max. 10W
Charge Current	0.1-10A
Discharge Current	0.1-5A
Balance Current	500mA/cell
LiPo/LiFe/LiIon/LiHV cell count	1-6 series
NiCd/NiMH battery cell count	1-15cells
Pb battery voltage	2V-20V (1-10cells)
Battery data memory	10 profiles
Weight	0.44kg
Dimension	135x95x61mm

INTRODUCTION



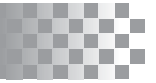

Optimized Operating Software

UP100AC Plus features the AUTO function that set the feeding current during the process of charging or discharging. Especially for lithium batteries, it can prevent the overcharging which may lead to an explosion. It can disconnect the circuit automatically and alarm once detecting any malfunction. All the programs of this product were controlled through two way linkage and communication, to achieve the maximum safety and minimize the trouble. All the settings can be configured by users!

Balancing Individual Cells For Battery Discharging

During the process of discharging, UP100AC Plus can monitor and balance each cell of the battery individually. Error message will be indicated and the process will be ended automatically if the voltage of any single one cell is abnormal.

Adaptable to Various Type of Lithium Battery

UP100AC Plus is adaptable to various types of lithium batteries, such as LiPo, Lilon, LiFe and the new generation of LiHV batteries.

Fast and Storage Mode of Lithium Battery

Purposes to charge lithium battery varies, 'fast' charge reduce the duration of charging, whereas 'store' state can control the final voltage of your battery, so as to store for a long time and protect useful time of the battery.

Cyclic Charging/Discharging

1 to 5 cyclic and continuous process of charge>discharge or discharge > charge is operable for battery refreshing and balancing to stimulate the battery's activity.

Re-Peak Mode of NiMH/NiCD Battery

In re-peak charge mode, the charger can peak charge the battery once, twice or three times in a row automatically. This is good for making certain the battery is fully charged, and for checking how well the battery receives fast charges.

SPECIAL FEATURES

Data Store/Load

The charger can store up to 10 different charge/discharge profiles for your convenience. You can keep the data pertaining to program setting of the battery of continuous charging or discharging. Users can call out these data at any time without any special program setting.

Terminal Voltage Control(TVC)

The charger allows user to change the end voltage.

LiPo Battery Meter

The user can check battery's total voltage, the highest voltage, the lowest voltage and each cell's voltage.

Maximum Safety

Delta-peak sensitivity for NiMH/NiCd battery: The automatic charge termination program based on the principle of the Delta-peak voltage detection. When the battery's voltage exceeds the threshold, the process will be terminated automatically.

Automatic Charging Current Limit

You can set up the upper limit of the charging current when charging your NiMH or NiCd battery, it is useful for the NiMH battery of low impedance and capacity in the 'AUTO' charging mode.

Capacity Limit

The charging capacity is always calculated as the charging current multiplied by time. If the charging capacity exceeds the limit, the process will be terminated automatically when you set the maximum value.

Temperature Threshold*

The battery's internal chemical reaction will cause the temperature of the battery to rise. If the temperature limit is reached, the process will be terminated.

**This function is available by connecting optional temperature probe, which is not included in the package.*

Processing Time Limit:

You can also limit the maximum process time to avoid any possible defect.

! Charging

During charge process, a specific quantity of electrical energy is fed into the battery. The charge quantity is calculated by multiplying charge current by charge time. The maximum permissible charge current varies depending on the battery type or its performance, and can be found in the information by the battery manufacturer. Only batteries that are expressly stated to be capable of quickcharge are allowed to be charged at rates higher than the standard charge current.

Connect the battery to the terminal of the charger: red is positive and black is negative. Due to the difference between resistance of cable and connector, the charger can not detect resistance of the battery pack. The essential requirement for the charger to work properly is that the charge lead should be of adequate conductor cross-section, and high quality connectors which are normally goldplated should be fitted to both ends.

Always refer to the manual by the battery manufacturer pertaining to charging methods. Operate according to their recommended charging current and charging time. Lithium batteries, in particular, should be charged strictly according to the manufacturer's instruction.

Close attention should be paid to the connection of lithium batteries.

Do not attempt to disassemble the battery pack arbitrarily. Please get highlighted that lithium battery packs can be wired in parallel and in series. In the parallel connection, the battery's capacity is calculated by multiplying single the battery's capacity by the number of cells, bearing in mind that total voltage stays the same. If the voltage is imbalanced, it may cause a fire or explosion. Lithium batteries are recommended to charge in series.

! Discharging

The main purpose of discharging is to clean the residual capacity of the battery, or to reduce the battery' voltage to a defined level. The same attention should be paid to the discharging process as the charging process. The final discharge voltage should be set up correctly to avoid deep discharging. Lithium batteries cannot be discharged to lower than the minimum voltage, or it will cause a rapid loss of capacity or a total failure. Generally, lithium batteries don't need to be discharged. Please pay attention to the minimum voltage of lithium batteries to protect them.

Some rechargeable batteries have a memory effect. If they are partly used and recharged before the whole charge is accomplished, they remember this and will only use that part of their capacity next time. This is a 'memory effect' It is said that NiMH and NiCD batteries are suffering from memory effect. NiCD has more 'memory effect' than NiMH.

Lithium batteries are recommended to be discharged partially rather than fully. Frequent full discharging should be avoided if possible. Instead, charge the battery more often or use a battery of larger capacity. Full capacity cannot be reached until it has been subjected to 10 or more charge cycles. The cyclic process of charge and discharge will optimize the capacity of battery pack.

LITHIUM BATTERY CONNECTION DIAGRAM

UP100AC Plus charger comes with the built in switch mode power supplies. You can connect the AC power cord directly to the main AC socket (100-240V AC), or you can connect an external power supply (12-18v) or 12v car battery to the DC input socket.

PLEASE NOTE: The charger **MUST** be powered before you connect a battery to the charger, failure to have the charger powered up before connecting a battery can cause charger failure if any connections are incorrect. The charger must to be powered in order for it to recognize an incorrect connection and warn you of this before you can go too far and cause damage. If you get the warning “Reverse Polarity” you **MUST** disconnect the battery immediately! Never remove power from the charger first.

Before connecting any battery it is absolutely essential to check one last time that you have set the charging parameters correctly. If the settings are incorrect, the battery may be damaged, and could even burst into flames or explode. Check that your wiring is correct polarity from the charger to your battery, double check to be safe.

To avoid short circuiting a battery you must always connect the charge leads to the charger first, and only then to the battery. Always unplug the battery from the charge leads when disconnecting the pack, never remove the leads from the charger when a battery is connected to them.

BALANCE SOCKET:

The balance wire attached to the battery must be connected to the charger with the black wire aligned with the negative marking. Take care to maintain correct polarity! (See the wiring diagram on the next page.)

CONNECTING THE BATTERY

To connect a lithium battery with a balance plug please follow these procedures.

LITHIUM BATTERY CONNECTION DIAGRAM

1. Connect charge leads to the charger, making sure polarity of all leads is correct.
2. Turn the charger on and check your settings that they match the battery pack you intend to charge.
3. Connect the main leads of the battery to the main leads of the charger.
4. Connect the balance lead of the battery to the correct balance port on the multi balance board. If in doubt as to which socket to use please ask your dealer for clarification.
5. Start the charge cycle, wait and watch that the charger starts to charge and shows correct readings on the screen.
6. When charging is finished disconnect the balance lead from the board, then disconnect the battery main leads from the charging lead.

This diagram shows the correct way to connect your battery to the UP100AC Plus while charging in the balance charge program mode only.



WARNING:

 Failure to connect will damage this charger.

PROGRAM FLOW CHART

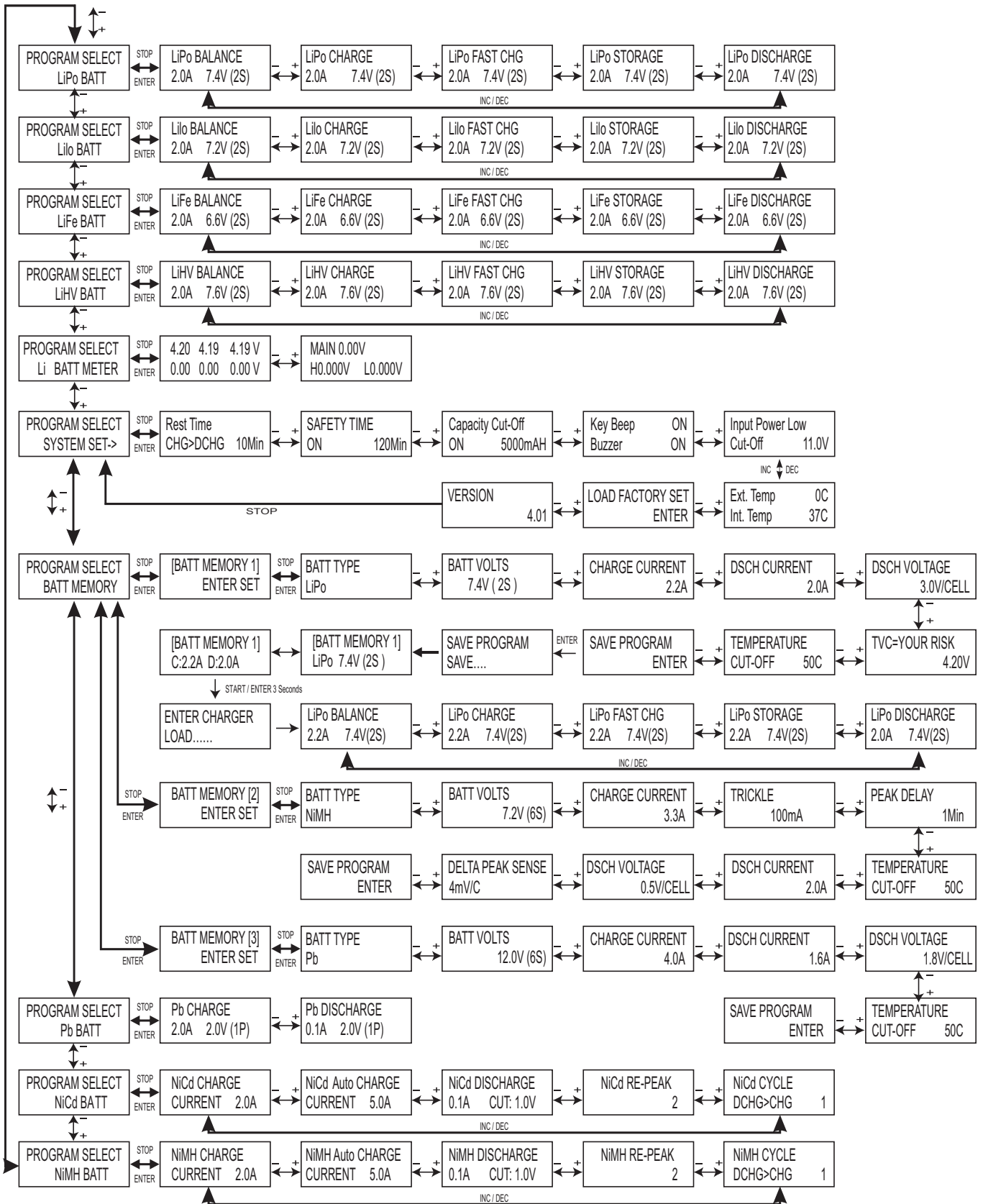

LITHIUM BATTERY(LiPo/LiFe/Lilon/LiHV)PROGRAM

These programs are only suitable for charging and discharging lithium batteries with a nominal voltage of 3.7V, 3.3V and 3.8V per cell. These batteries need to adopt different charge technique which is termed as constant voltage(CV) and constant current(CC) method. The charge current varies according to the battery capacity and performance. The final voltage of charge process is also very important; it should be precisely matched with the charge voltage of the battery. They are 4.2V for LiPo, 3.6 V for LiFe, 4.1V for Lilon and 4.35V for LiHV. The charge current and nominal voltage as for cell count set on the charge program must always be correct for the battery to be charged.

CHARGING LITHIUM BATTERY AT BALANCE MODE

This function is for balancing the voltage of lithium-polymer battery cells while charging.

In the balance mode, the battery needs to connect to the battery's power lead with balance wire.

In this mode, the charging process will be different from ordinary charging mode. The internal processor of the charger will monitor the voltages of each cell of the battery pack and control charging current which is feeding to each cell to equalize the voltage.

Note: We recommend charging lithium batteries with a balance wire in the balance mode only.

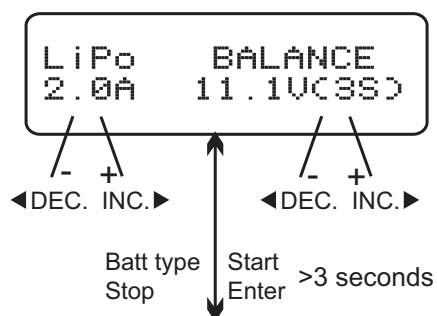

The left side of the first line shows the type of battery you choose. The value on the left of the second line of the charger is current the user sets. After setting the current and voltage, press the START/ENTER button for more than 3 seconds to start the process.

LITHIUM BATTERY(LiPo/LiFe/Lilon/LiHV)PROGRAM

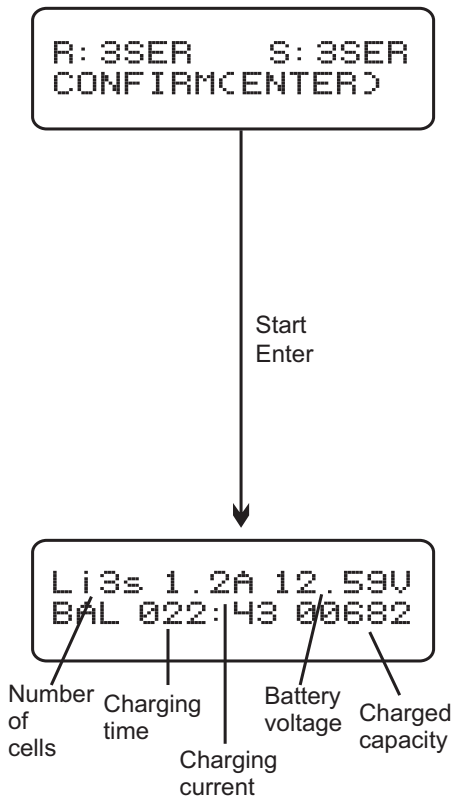

This screen displays the number of cells you set up and the processor detects.
 R=Number of cells detected by charger.
 S=Number of cells set by you at the previous screen.
 If both numbers are identical you can start charging process. If not, press BATT TYPE/ STOP button to go back to previous screen to recheck the number of cells of the battery pack before going ahead.

This screen shows the real-time status during charge process. Press BATT TYPE/STOP button once to stop the charge process.

CHARGING OF LITHIUM BATTERY

This charging mode is for charging LiPo/LiFe/Lilon/LiHV battery in normal mode.

Note: We recommend charging lithium batteries with a balance lead in the balance mode only.

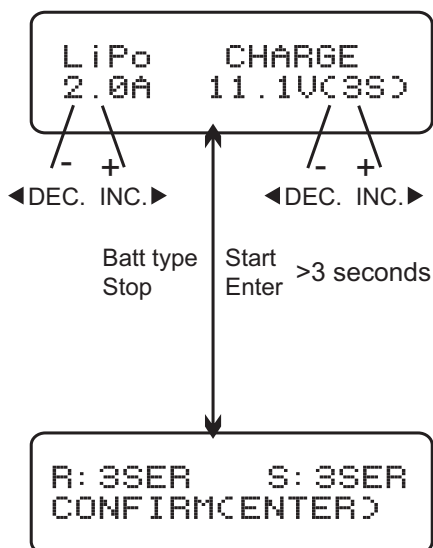

The left side of the first line shows the type of battery you choose. The value on the left of the second line of the charger is current the user sets. After setting the current and voltage, press the START/ENTER button for more than 3 seconds to start the process.

This displays the number of cells you set up and the processor detects.
 R=Number of cells detected by charger.
 S=Number of cells set by you at the previous screen.

LITHIUM BATTERY(LiPo/LiFe/Lilon/LiHV)PROGRAM

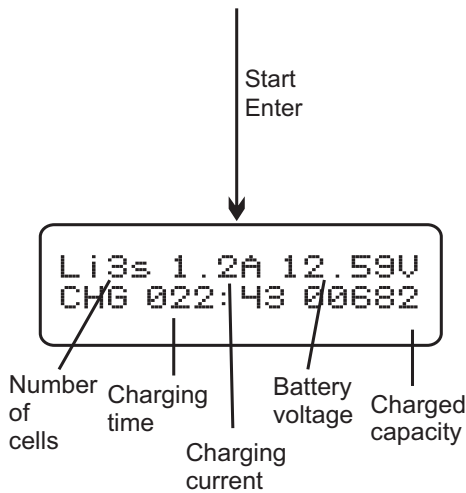

If both numbers are identical you can start charging process. If not, press BATT TYPE/ STOP button to go back to previous screen to recheck the number of cells of the battery pack before going ahead.

This screen shows the real-time status during charge process. Press BATT TYPE/ STOP button once to stop the charge process.

'FAST' CHARGING OF LITHIUM BATTERY

Charging current will drop towards the end of charging, a specific CV process is reduced to the charging process earlier. In fact, the charging current reach 1/5 when the charging process comes to 1/10 during CV period, charging capacity is a little smaller than normal charging but charging time is shorted accordingly.

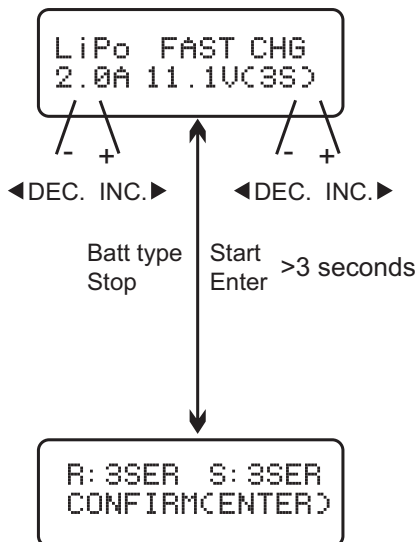

The value on the left side of the second lines shows the charge current. The value on the right side of the second lines shows the battery pack's voltage. After setting current and voltage, press the START/ENTER button for more than 3 seconds to start the process.

This displays the number of cells you set up and the processor detects.

R=Number of cells detected by charger.

S=Number of cells set by you at the previous screen.

LITHIUM BATTERY(LiPo/LiFe/LiIon/LiHV)PROGRAM

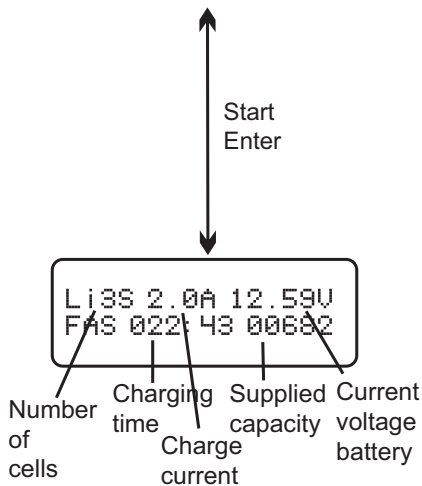

If both numbers are identical you can start charging process. If not, press BATT TYPE/ STOP button to go back to previous screen to recheck the number of cells of the battery pack before going ahead.

This screen shows the real-time status during charge process. Press BATT TYPE/STOP button once to stop the charge process.

'STORAGE' CONTROL OF LITHIUM BATTERY

This function is for charging/discharging batteries which are not used at once. This program is designed for charging or discharging of batteries of specific original state. They are classified by types: 3.7V Lilon, 3.8V LiPo, 3.3V LiFe and 3.9V LiHV. The program will begin to discharge if the original state of battery exceeds the voltage level of storage.

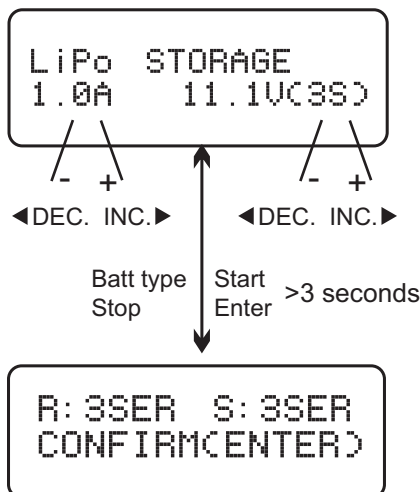

At this screen, you can set up the current and voltage of the battery pack. Charging and discharging will make the batteries come to the voltage level of storage state.

This screen displays the number of cells you set up and the processor detects. R=Number of cells detected by charger. S=Number of cells set by you at the previous screen.

If both numbers are identical you can start charging process by press START/ENTER button. If not, press BATT TYPE/STOP button to go back to previous screen to recheck the number of cells of the battery pack before going ahead.

LITHIUM BATTERY(LiPo/LiFe/LiIon/LiHV)PROGRAM

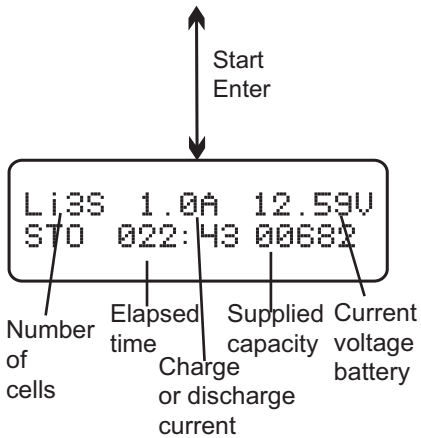

This screen shows the real-time status charging. Press BATT TYPE/STOP button once to stop the charge process.

DISCHARGING LITHIUM BATTERY

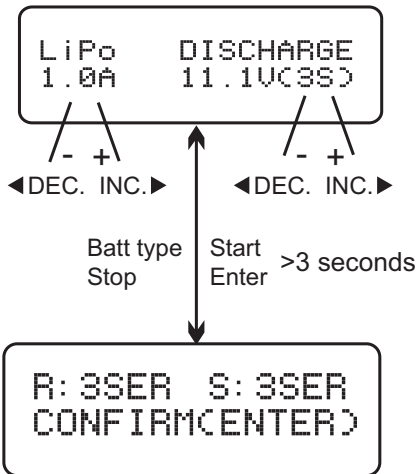

The value of discharge current on the left can not exceed 1C, and the value on the right can not be under the voltage recommended by the manufacturer to avoid over discharging. press the START/ENTER button for more than 3 seconds to start discharging.

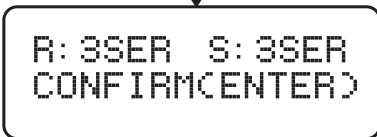

This screen displays the number of cells you set up and the processor detects. R=Number of cells detected by charger. S=Number of cells set by you at the previous screen.

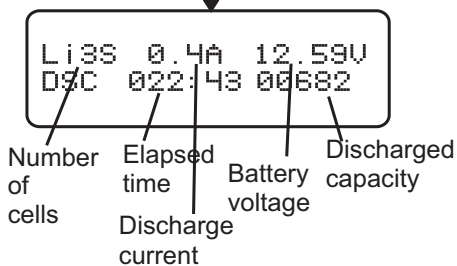

If both numbers are identical you can start charging process. If not, press BATT TYPE /STOP button to go back to previous screen to recheck the number of cells of the battery pack before going ahead.

This screen shows the real-time status of discharging, you can press BATT TYPE/STOP button to stop discharging.

PB BATTERY PROGRAM

This program is only suitable for charging Pb lead-acid battery with nominal voltage from 2 to 20V, Pb lead-acid battery is a completely different from NiMH/NiCD battery. These batteries can only deliver current lower in comparison to their capacity. The same restriction applies to the charging process consequently, the optimum charge current can only be 1/10 of the capacity. Pb battery can not be used for fast-charging. Please follow the instructions provided by the battery manufacturer.

CHARGING OF PB BATTERY

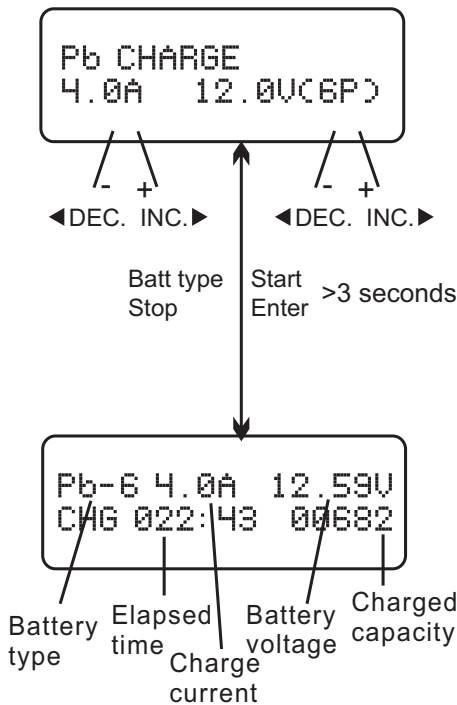

Set up the charge current on the left and nominal voltage on the right. Range of current 0.1-10.0A the voltage should match the battery being charged. Press START/ENTER button for more than 3 seconds to start charging.

The screen display the real-time charging status. Press START/ENTER button again to store the parameter value you set. Press BATT TYPE/STOP button to end the program.

DISCHARGING OF PB BATTERY

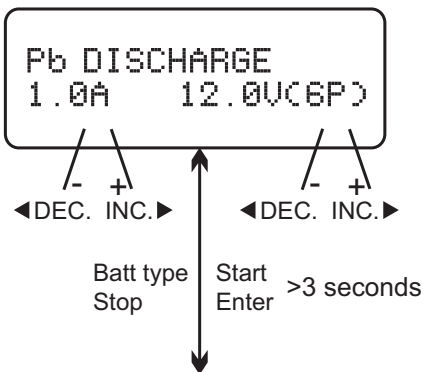

Set up the discharge current on the left and nominal voltage on the right. Range of discharge current is 0.1-5.0A the voltage should match the battery being discharged. Press ENTER/START button for more than 3 seconds to start discharging.

PB BATTERY PROGRAM

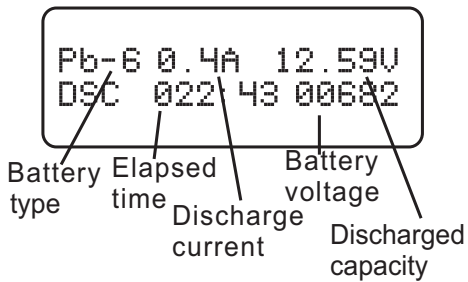

The screen display the real-time discharging status. Press START/ENTER button to change the discharging value. Press START/ ENTER button again to store the parameter value you set. Press BATT TYPE/STOP button to end the program.

NIMH/NICD BATTERY PROGRAM

CHARGING OF NIMH/NICD BATTERY

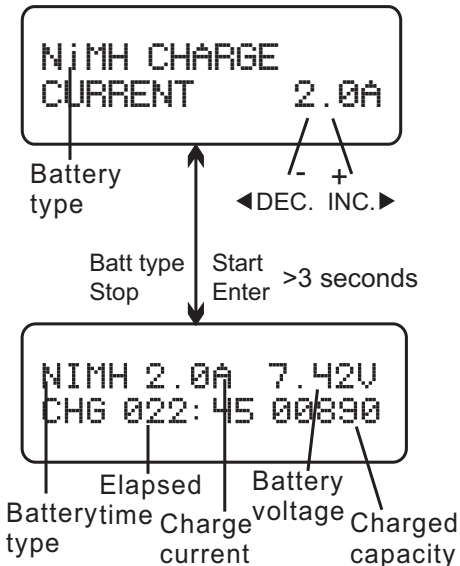

This program is for charging and discharging of NiMH/NiCD batteries associated with R/C models applications. You can press Inc. or Dec. button to change the parameter value, press START/ENTER button to store the value.

The screen displays the real-time charging status. Press BATT TYPE/STOP button to stop the process. The audible sound indicate the end of process.

CHARGING NIMH/NICD BATTERY IN THE AUTO CHARGE MODE

In this program the charger detects the condition of the battery which is connected to the output and automatically charges the battery. In this mode, you should set up the upper limit of the charge current to avoid damage by excessive feeding current. Some batteries of low resistance and capacity can lead to higher current in the auto charging mode.

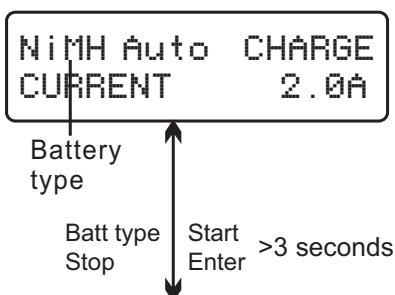

The program is for charging of NiMH/NiCD batteries in auto mode.

You can make it blink in the current field and press INC. or DEC. to switch mode.

NIMH/NICD BATTERY PROGRAM

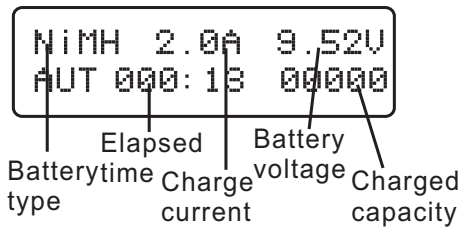

The screen displays real-time charging status. Press BATT TYPE/STOP button to stop the process.

The audible sound indicates the end of process.

CHARGING NIMH/NICD BATTERY IN RE-PEAK CHARGE MODE

Re-peak Charge Mode (NiMH and NiCD batteries only): In re-peak charge mode, the charger can peak charge the battery once, twice or three times in a row automatically. This is good for confirming the battery is fully charged, and for checking how well the battery receives fast charges. A five minute cool-off delay occurs after each re-peak charge. Press START/ENTER button more than 3 seconds to start the charging.

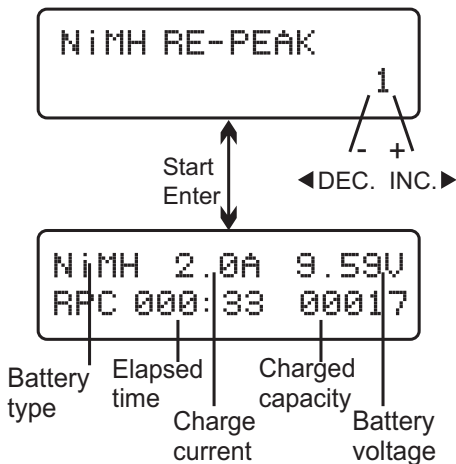

Re-peak cycle number 1 shows on the display.

Press the START/ENTER button to make the re-peak cycle number blink and press INC. or DEC. button to find the desired number of times to re-peak charge the battery. Press the START/ENTER button to confirm selection.

DISCHARGING OF NIMH/NICD BATTERY

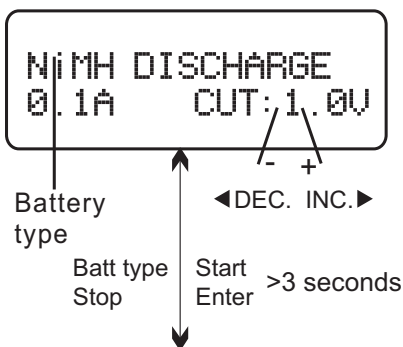

Set discharge current on the left and final voltage on the right.

Range of the discharge current is 0.1-5.0A; range of final voltage is 0.1-25.2V. Press START/ENTER button for more than 3 seconds to start the program.

NIMH/NICD BATTERY PROGRAM

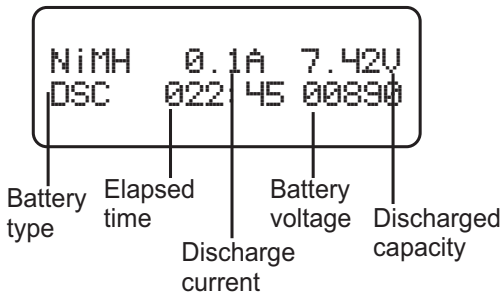

The screen indicates the discharging state. you can press START/ENTER button to alter discharge current, Press START/ENTER button again to store the value, Press BATT TYPE/STOP button to stop discharging. The emitted sound alerts the end of discharging.

CHARGE/DISCHARGE & DISCHARGE/CHARGE CYCLE OF NIMH/NICD BATTERY

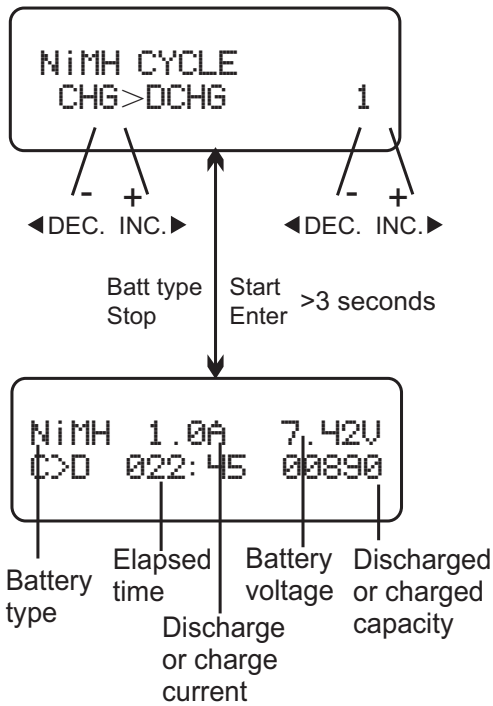

You can set up sequence on the left and the number of cycles on the right. Range of the cycle number is 1-5.

Press BATT TYPE/STOP button to stop program, you can press Inc. or Dec. button to alter charge current, the sound indicates the end of program.

BATTERY MEMORY SET

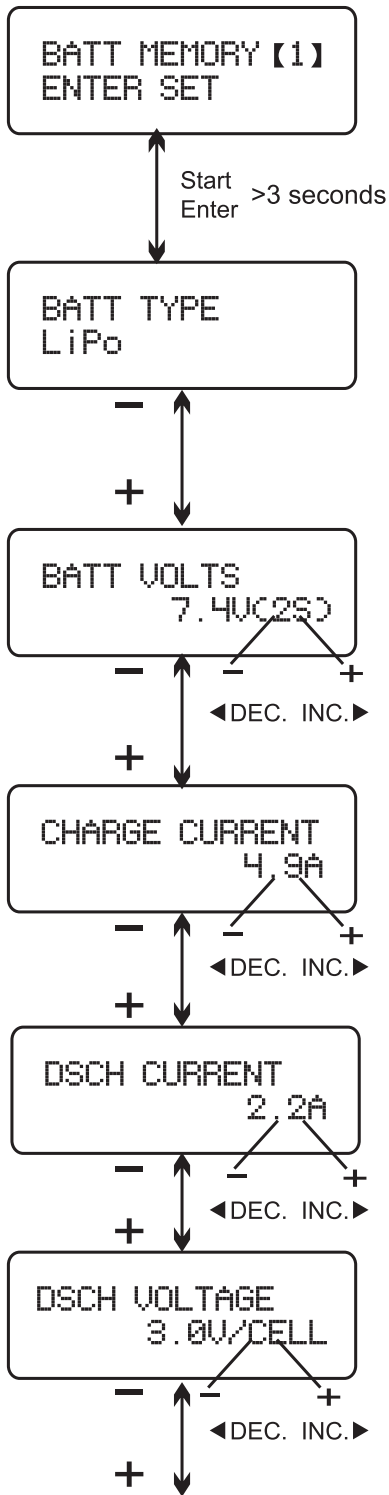

For your convenience UP100AC Plus has a data storage and load program, it can store 10 different battery data represent the respective specifications of batteries, you can call back the data when charging/discharging without setting up the program again, press START/ ENTER button to make it blink and use INC. or DEC. to set up the parameter.

The example is Lipo battery pack (2S/7.4V).

Set the voltage and number of cells, along with the normal voltage (1S-6S).

Set the charge current, it can be adjusted 0.1-10.0A.

Set the discharge current, it can be adjusted 0.1-5.0A.

Set the discharge voltage, it can be adjusted (3.0-3.3V/Cell).

BATTERY MEMORY SET

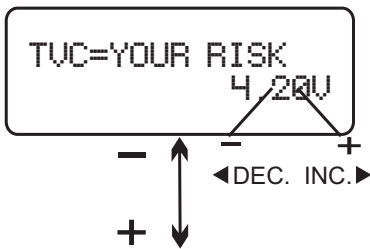

Set the terminal voltage, it can be adjusted (4.18-4.30V)

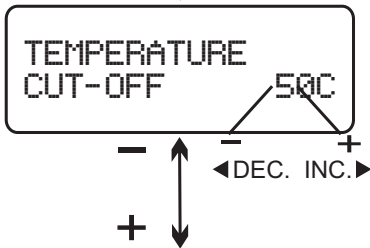

Set the cut-off temperature, it can be adjusted(20°C/68°F-80°C/176°F).

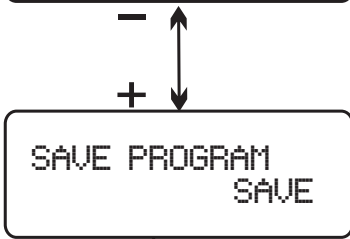

Press the START/ENTER button more than 3 seconds to save the program.

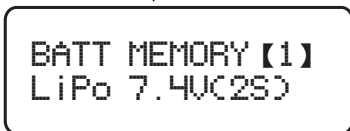
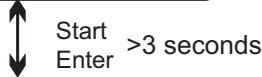

This screen indicate the saved profile.

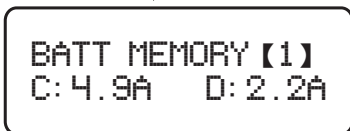

This program is to load the data stored at the "save data" program.

Press the START/ENTER button more than 3 seconds to load a memory, otherwise, you only enter to the setting mode.

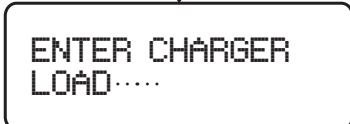
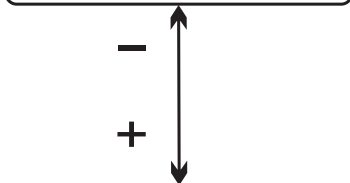

Loading the data.

LITHIUM BATTERY METER

The user can check battery's total voltage, the highest voltage, the lowest voltage and each cell's voltage.

Please connect the battery to the charger with main battery lead and balance wires to balance socket.



```
PROGRAM SELECT
Li BATT METER
```

Press the START/ENTER button to enter the Lithium Battery Meter program.

Start
Enter

```
4.19 4.15 4.18V
0.00 0.00 0.00V
```

The screen indicate each cell's voltage.

-
+

```
MAIN 12.52V
H4.190V L4.160V
```

The screen indicate the total voltage, the highest voltage, and the lowest voltage.

SYSTEM SET UP

It will be operated with the default value of the essential user settings when it is connected to a DC 11~18V battery at the first time. The screen displays the below information in sequence and the user can change the value of parameter on each screen.

Press START/ ENTER button to make it blink then change the value by press Dec. or Inc. button. The value will be stored by press START/ ENTER button again.

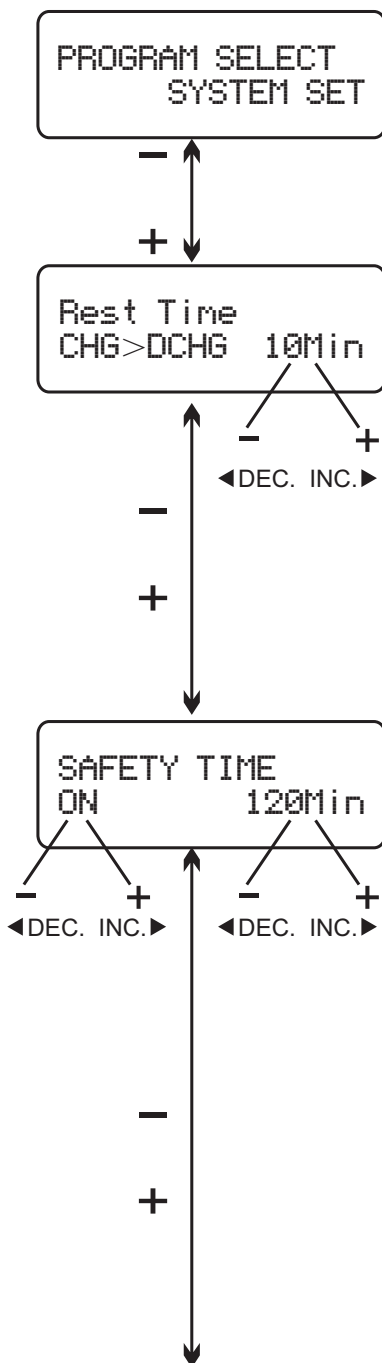

User set up starting screen.

The battery is on the cyclic process of charge and discharge can often become warm after charge or discharge period. The program can insert a time delay to occur after each charge and discharge process to allow the battery adequate time to cool down before being subjected to the next process. The value ranges from 1 to 60 minutes.

When you start a charge process, the integral safety time automatically starts running at the same time. This is programmed to prevent overcharge the battery if it proves to be faulty, or if the termination circuit cannot detect the battery full. The value for the safety time should be generous enough to allow a full charge of the battery.

Safe time Calculation

When charging NiMH or NiCD batteries, divide the capacity by current, then divide the result

by 11.9, set this number as the value for safety time setting. If the charger stopped at this threshold, about 140% of the capacity will have been fed into the battery.

For example:

Capacity	Current	Safety Time
2000mAh	2.0A	$(2000/2.0=1000)/11.9=84$ minutes
3300mAh	3.0A	$(3300/3.0=1100)/11.9=92$ minutes
1000mAh	1.2A	$(1000/1.2=833)/11.9=70$ minutes

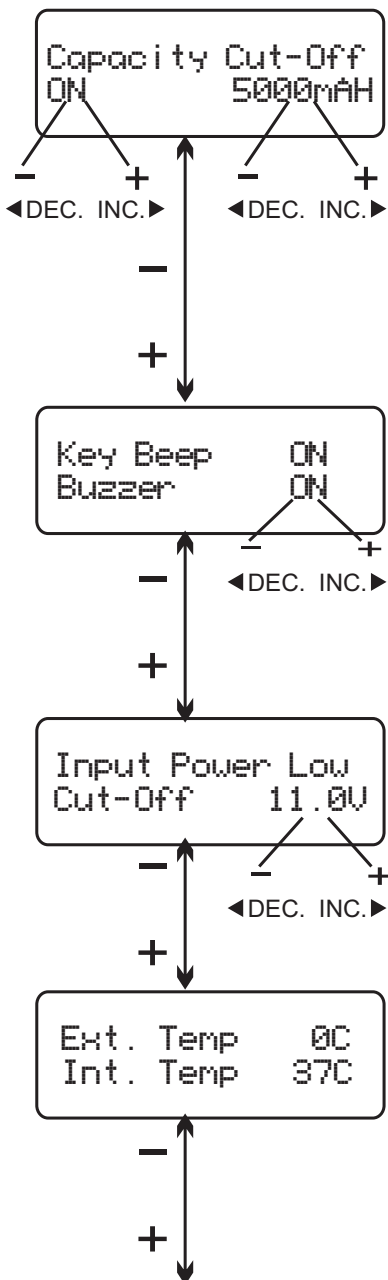

This program sets the maximum charge capacity that will be supplied to the battery during charge. If the deltapack voltage is not detected nor the safety time expired by any reason, this feature will automatically stop the process at the selected capacity value.

The beep sounds at every time pressing the buttons to confirm your action. The beep or melody sounded at various times during operation to alert different mode changes. These audible sounds can be on or off.

This program monitors the voltage of input battery. If the voltage drops below the value you set the operation forcibly terminated to protect the input battery.

This screen shows the external and internal temperature.

VARIOUS INFORMATION DURING THE PROCESS

```
LOAD FACTORY SET
ENTER
```

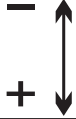

```
VERSION
1.00
```

Press the Start/Enter button for 3 more than seconds to load the factory set.

This screen shows the version.

VARIOUS INFORMATION DURING THE PROCESS

You can inquire various information on LCD screen during charging or discharging process. When you press Dec. button, the screen will display the user's settings.

And also you can monitor the voltage of individual cell by press Inc. button when the individual connection cable is linked to the Lithium battery being processed.

```
End Voltage
12.6V(3S)
```

It comes to the final voltage when the program ended.

```
IN Power Voltage
12.56V
```

Present input voltage.

```
Ext. Temp 0C
Int. Temp 26C
```

This screen shows the internal temperature.

```
Safety Time
ON 200min
```

Displayed safety time is turn on and duration of time in minutes.

```
Capacity Cut-Off
ON 5000mAh
```

Displayed capacity cut-off function is turn on and the setting value of capacity.

```
4.19 4.15 4.18V
0.00 0.00 0.00V
```

The battery is connected with balance lead, you can check voltage of each cell in the battery pack.

WARNING AND ERROR MESSAGE

It incorporates a variety of functions for the systems to verify processes and the state of the electronics. In case of an error the screen will display the cause of error and emit an audible sound.

REVERSE POLARITY	Incorrect polarity connected.
CONNECTION BREAK	The battery is interrupted.
CONNECT ERROR CHECK MAIN PORT	The Battery connection is wrong.
BALANCE CONNECT ERROR	The balance connect is wrong.
DC IN TOO LOW	Input voltage less than 11V.
DC IN TOO HIGH	Input voltage higher than 18V.
CELL ERROR LOW VOLTAGE	Voltage of one cell in the battery pack is too low.
CELL ERROR HIGH VOLTAGE	Voltage of one cell in the battery pack is too high.
CELL ERROR VOLTAGE-INVALID	Voltage of one cell in the battery pack is invalid.
CELL NUMBER INCORRECT	The cell number is wrong.
INT. TEMP. TOO HI	The internal temperature of the unit goes too high.
EXT. TEMP. TOO HI	The external temperature of the unit goes too high.
OVER CHARGE CAPACITY LIMIT	The battery capacity is more than the maximum capacity which the user sets.
OVER TIME LIMIT	The charging time is longer than the maximum charging time which the user sets.
BATTERY WAS FULL	The battery voltage is higher than the maximum voltage which the user sets when charging in balance mode.

WARRANTY AND SERVICE



Thank you for purchasing UP100AC Plus charger by Ultra Power. We guarantee this product to be free of manufacturing and assembly defects for a period of one year from the time of purchase. The warranty only applies to material or operational defects, which are present at the time of purchase. During that period, we will repair or replace free of service charge for products deemed defective due to those causes.

You will be required to produce proof of purchase (invoice or receipt). This warranty is not valid for any damage or subsequent damage arising as a result of misuse, modification or as a result of failure to observe the procedures outlined in this manual.

ULTRA POWER



Manufactured by
Ultra Power Technology Limited
www.ultrapower.hk
E-mail: info@ultrapower.hk