

roqprint
fit
P08

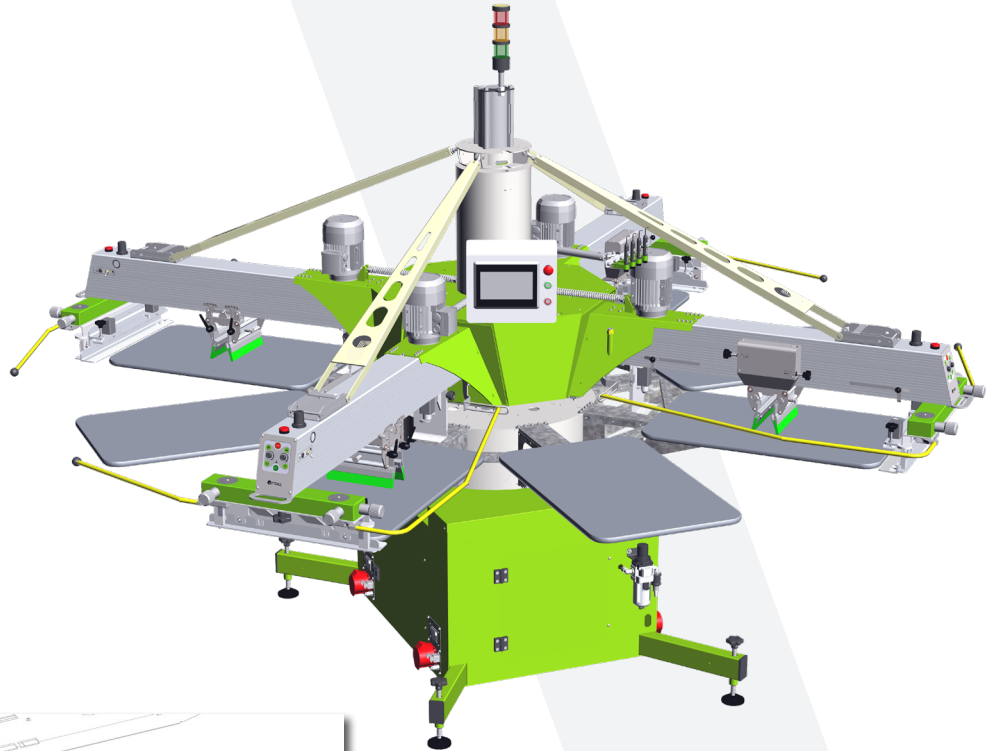

Allows the use of Roq pallets.

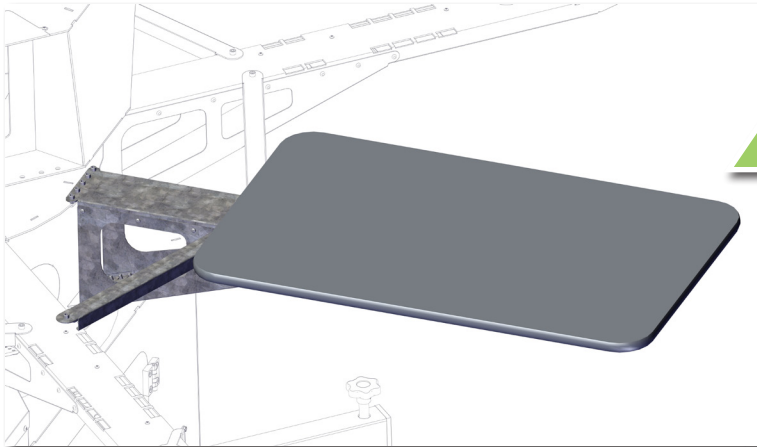

Thinner pallet holder!
Allows to print sleeves easily.
23"x31" printer frames.
Compatible with the standard brackets.

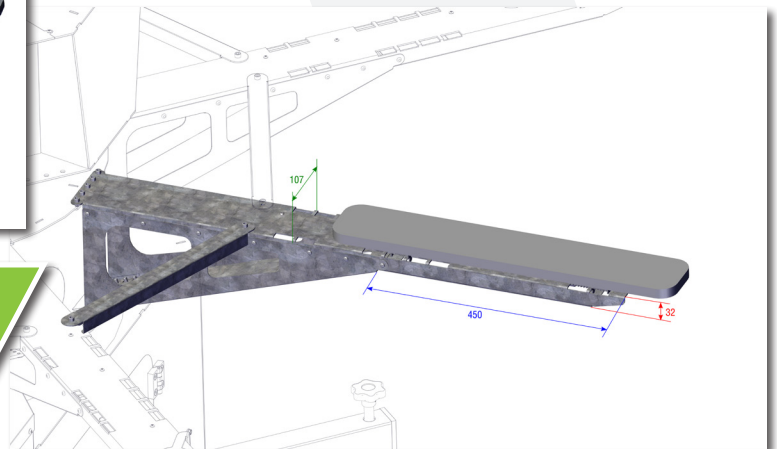

Versatile

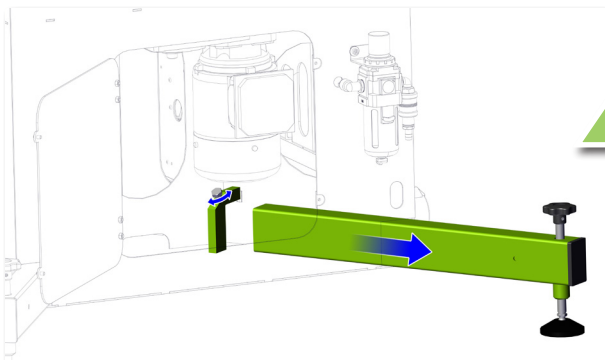

Easy to move

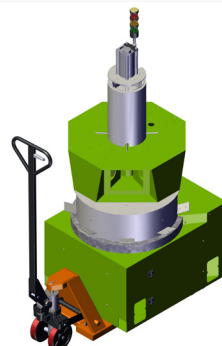

roqprint fit P08

roqinternational.com

S.ROQUE - Máquinas e Tecnologia Laser, S.A.
RUA DAS RIBES, 400
4765-774 OLIVEIRA S. MATEUS
PORTUGAL
Tel.: +351 252 980 500
Fax: +351 252 980 501
e-mail: info@sroque.pt

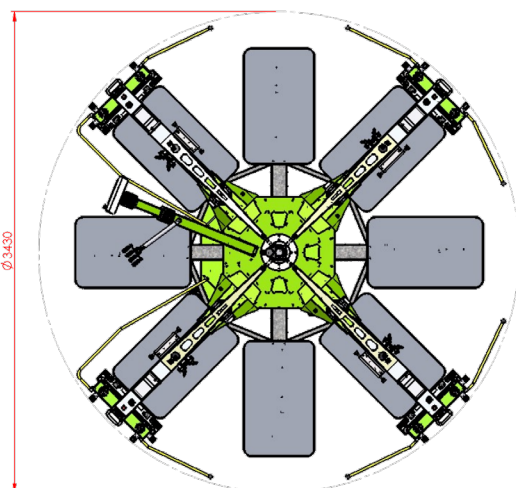
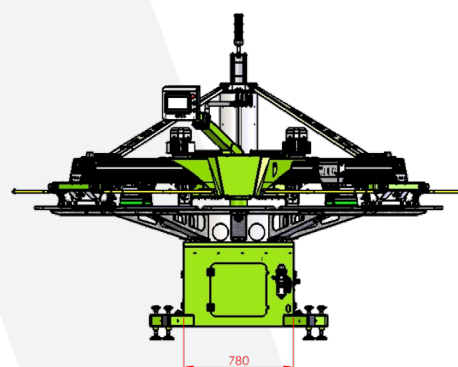
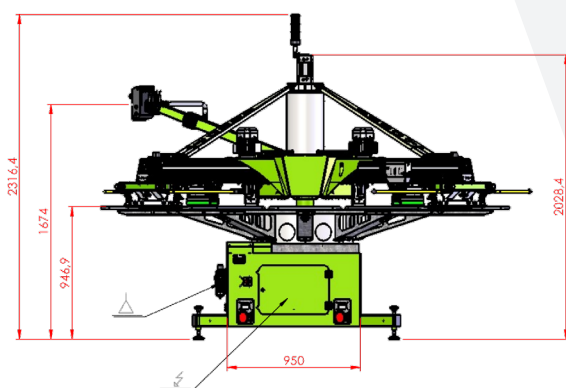

ROQPRINT FIT	P08
number of colors (max.)	4
number of pallets	8
maximum pre-drying connections (optional)	4
maximum print size (mm/pol)	420 x 440 / 16,5" x 17"
max. size of the external frame (mm/pol)	580 x 790 / 23" x 31"
maximum pallet size (mm/pol)	450 x 700 / 17,7" x 27,6"
maximum frame profile size (mm/pol)	50 x 50 / 2" x 2"
rapport precision (mm/pol)	+/-0.025 / 0.001"
maximum production (pieces/h) *	1000
air compressed consumption (l/min. 7 bar)**	250 l/min - 8.9 cfm + number of each printhead
maximum consumption (kVA) ***	2
machine diameter (mm/feet)	3430 / 11.3'
total height (mm/feet)	2316 / 7.72'
minimum width of the base (mm/feet)	780 / 2.67'

* one squeegee with flooding for a A4 print.

** consumption of each electric printhead: 15l/min | 0.5cfm in 15 pieces/min.

*** these values exclude the consumption with flash-curing, they should be calculated separately, taking into account the number and model of the flash cure on the machine.

- power supply: 220V, 3x220V, 3x400V - 50Hz or 60Hz