



ACOUSTICS

3060S

OWNER'S MANUAL

EN	ENGLISH	03
DE	GERMAN	20
FR	FRENCH	36
IT	ITALIAN	52

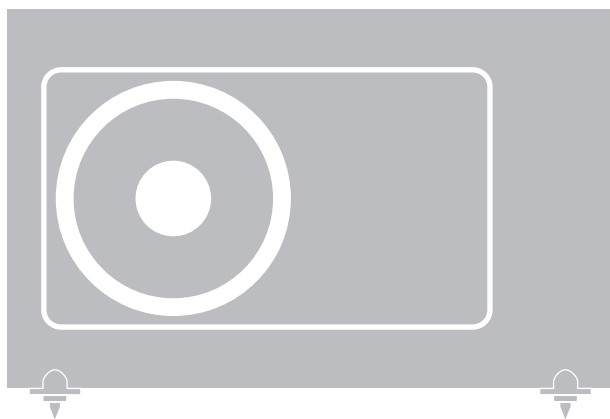

Designed and engineered in the United Kingdom.

Important Safety Information and Warnings

IMPORTANT INFORMATION - PLEASE READ CAREFULLY



This symbol indicates that there are important operating and maintenance instructions in the literature accompanying this unit.



This symbol indicates that dangerous voltage constituting a risk of electric shock is present within this unit.

Read these instructions.
Keep these instructions.
Heed all warnings.
Follow all instructions.
Do not use this apparatus near water.
Clean only with dry cloth.
Do not block any ventilation openings.

Install in accordance with the manufacturer's instructions.

Do not install near any heat sources such as radiators, heat registers, stoves, or other apparatus (including amplifiers) that produce heat.

Do not defeat the safety purpose of the polarized or grounding type plug. A polarized plug has two blades with one wider than the other. A grounding type plug has two blades and a third grounding prong. The wider blade or the third prong are provided for your safety. If the provided plug does not fit into your outlet, consult an electrician for replacement of the obsolete outlet.

Protect the power cord from being walked on or pinched, particularly at plugs, convenience receptacles, and the point where they exit from the apparatus.

Use only attachments/accessories specified by the manufacturer. Use only with a cart, stand, tripod, bracket, or table specified by the manufacturer, or sold with the apparatus.

When a cart is used, use caution when moving the cart/apparatus combination to avoid injury from tip-over.



Unplug this apparatus during lightning storms or when unused for long periods of time.

Refer all servicing to qualified service personnel. Servicing is required when the apparatus has been damaged in any way, such as power supply cord or plug is damaged, liquid has been spilled or objects have fallen into the apparatus, the apparatus has been exposed to rain or moisture, does not operate normally, or has been dropped.

Warning: To reduce the risk of fire or electrical shock, do not expose this product to rain or moisture. The product must not be exposed to dripping and splashing and no object filled with liquids such as a vase of flowers should be placed on the product.

No naked flame sources such as candles should be placed on the product.

Warning: The mains power switch for the subwoofer is the device used to disconnect the unit from the mains supply. This switch is located on the rear panel. To permit free access to this switch, the apparatus must be located in an open area without any obstructions, and the switch must be freely operable.

Caution: Changes or modifications not expressly approved by the manufacturer could void the user's authority to operate this device.

Service: Equipment for servicing should be returned to the supplying dealer, or to the service agent for your area. The addresses of the main Service Agents for the UK are listed in this manual.

Third parties: In the unlikely event that you pass this product on to a third party, include these operating instructions with the product.

Important notice to UK users

The appliance cord is terminated with a UK approved mains plug fitted with a 3A fuse. If the fuse needs to be replaced, an ASTA or BSI approved BS1362 fuse rated at 3A must be used. If you need to change the mains plug, remove the fuse and dispose of this plug safely immediately after cutting it from the cord.

Connecting a mains plug

The wires in the mains lead are coloured in accordance with the code: Blue: NEUTRAL; Brown: LIVE.

As these colours may not correspond to the coloured markings identifying the terminals in your plug, proceed as follows:

The BLUE wire must be connected to the terminal marked with the letter N or coloured BLUE or BLACK. The BROWN wire must be connected to the terminal marked with the letter L or coloured BROWN or RED.

To completely disconnect this apparatus from the AC Mains, disconnect the power supply cord plug from the AC receptacle.

Where the MAINS plug or an appliance coupler is used as the disconnect device, the disconnect device shall remain readily operable.

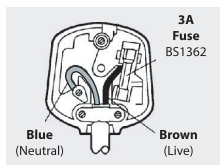

Introduction

Thank you for purchasing Q Acoustics.

This manual is intended to take you through setup and installation and will help provide optimum performance from the product.

Please read the instructions, important safety information and warnings carefully before installation and use, to ensure the safe and satisfactory operation of this product.

The Q Acoustics 3000i series is a range of loudspeakers designed to meet the highest expectations of dedicated 2-channel audiophiles and discerning movie enthusiasts.

The range comprises:

3010i: Compact bookshelf speaker with a 100 mm (4.0 inches) bass driver.

3020i: Bookshelf speaker with a 125 mm (5.0 inches) bass driver.

3050i: Floorstander with 2 x 165 mm (6.5 inches) bass drivers.

3060S: 150 Watt active subwoofer with a 200 mm (8.0 inches) driver.

3090Ci: Centre channel with 2 x 100 mm (4.0 inches) bass drivers.

In the carton you will find: The loudspeaker/s and this product manual.

In addition the packing for the following models contains:

3050i: Rear stabiliser, spikes and spike covers for each speaker. An Allen key to adjust the spikes once fitted.

3060S: A mains power cord or cords, spikes and spike covers.

Check the product carefully. If any items are damaged or missing, report this to your dealer as soon as possible.

We hope you enjoy the Q Acoustics experience.

Preparation



Lift the speakers from the cartons by holding the cabinets. Do not touch the driver units or use the protective bags to lift them. The 3050i and 3060S are heavy - get assistance to lift them if necessary.

Thread the locking nut onto the spike and screw all four spikes into the feet on the subwoofer. If you have a wood or stone floor push a spike protector over each spike before turning the speaker upright. When the speaker is the right way up adjust all the spikes until the loudspeaker is level and stable.

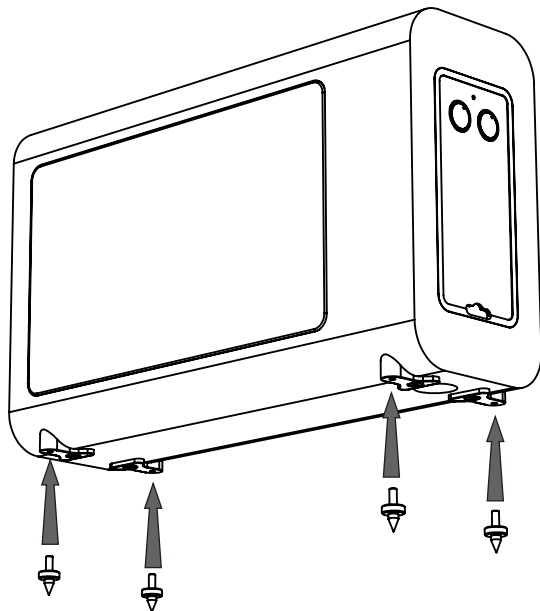

*Spikes are sharp. Exercise care!
Never place a spiked loudspeaker where it can cause damage!
Always move your loudspeakers by lifting them - never drag them!*

Positioning

Bass frequencies are substantially omni directional. Although this means that you can position the subwoofer almost anywhere, the stereo image will still benefit by positioning the subwoofer level with the front loudspeakers and as central to the listening position as possible. This may not be feasible in a multichannel system. If you place the subwoofer close to a wall the bass will be re-enforced therefore in some locations the bass may be boomy and indistinct.

The subwoofer should be positioned close to a mains power source. Do not use extension cables. Purchase a longer power cord if necessary.

The Power Switch is the means of disconnecting this apparatus from the mains and is mounted on the control panel.

When positioning the subwoofer ensure the floor is sound with no loose floorboards etc. The air movement from the subwoofer at high volumes is substantial - do not place it close to soft furnishings or objects that may rattle. Do not place objects of any kind on the unit.



All the loudspeakers may be operated close to TV monitors with no ill-effects with the exception of the 3060S which should not be operated within 500mm of TV screens monitors or other magnetically sensitive equipment. Plasma and LCD screens are unaffected.

Controls and Connections

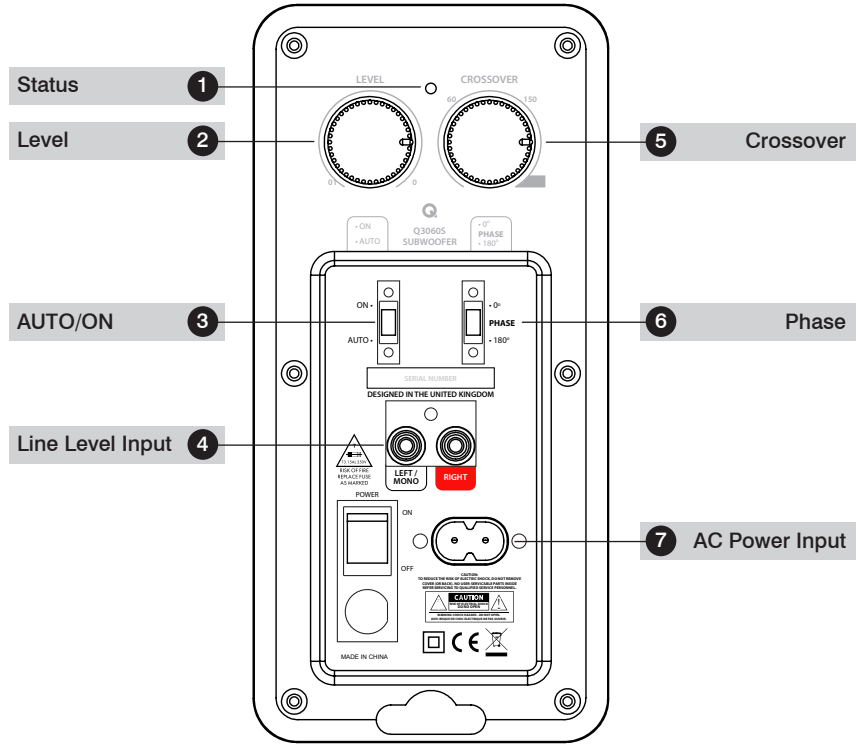
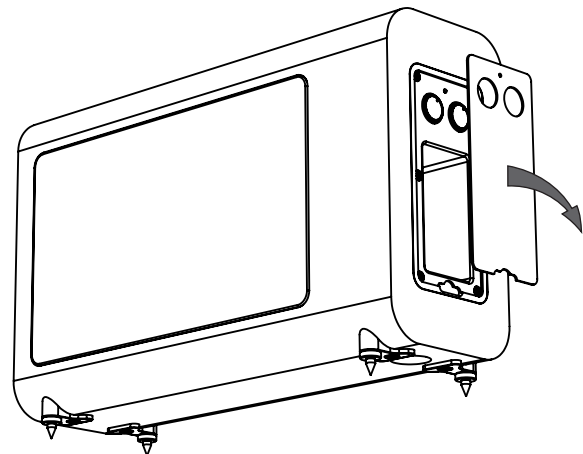

Controls and Connections



With this switch set to AUTO, when not in use the subwoofer shuts down to save power and switches on when it senses a signal. This can be over-ridden by switching ON.



The Phase Switch (2) changes the phase of the subwoofer so that it works in phase with the rest of the speakers in the system. Place the subwoofer more than 1 metre away from the front speakers and switch the phase between 0° and 180°. When the subwoofer sounds louder and fuller then it is in phase.

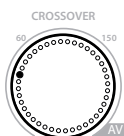

The Crossover Control (3) changes the pitch at which the subwoofer starts to work. It is recommended that the crossover point is set to the 'AV' setting on the dial when used with the 3000 System. If you are using the subwoofer with a non Q Acoustics system then you can change the crossover point to suit your system.

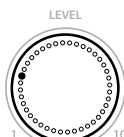

The Level Control (4) increases or decreases the volume of your subwoofer in relation to the other speakers in the system. Start with the volume at 0 on the dial then turn it up slowly until you can hear it. The subwoofer should be heard as part of the overall sound and not overpower the rest of the system. There is no rule for setting the volume on your subwoofer so experiment with different music and films to set it to your tastes.

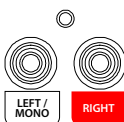

The Line Level Input-LFE (6) is Q Acoustics preferred AV connection to the amplifier.

Connect the subwoofer to the output on your AV amplifier or DVD player. Use R and L if your amplifier output is split left and right.

Multi-Channel AV System

For Stereo System connection, see next section.

Connections

Standard Connection is via the Line level RCA phono Inputs. For a typical AV system set-up you will need a single RCA phono interconnect. As this cable is likely to be quite long, make sure you get a good quality fully screened cable. Your Q Acoustics dealer will be happy to supply you with a suitable interconnect.

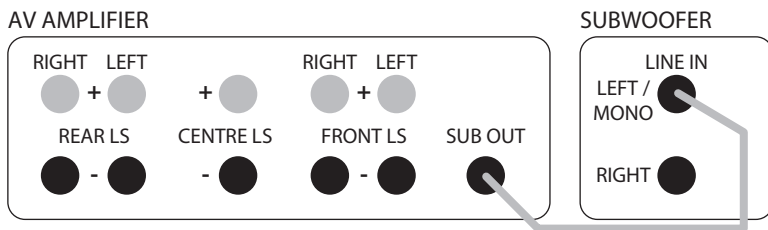

Connect the SUBWOOFER OUTPUT on the AV amplifier to the L/Mono Line input on the subwoofer, pushing the plugs firmly home to ensure a good contact.

Setting Up

Check that all system connections are properly and securely made. Ensure that the subwoofer is switched off.

Set the controls to the following default settings:

Level	Approximately half
Crossover	Fully clockwise (AV setting)
Phase invert	0°
Auto on	AUTO or ON

Plug the supplied power cord into the subwoofer and then into the AC supply socket. Switch on the power at the supply socket and then switch the power switch on the subwoofer to 'ON'. The POWER light on the subwoofer amplifier panel will glow and the subwoofer is operational.

Check the settings on your AV amplifier to make sure that the subwoofer is set to 'ON' or YES. The subwoofer level on the AV amplifier should be set at its default position or 0dB. You should already have set the speaker sizes and positions for all the other speakers in your system. If you have the option to set the crossover frequency on the other channels make sure this is set appropriately to your speakers: the 3010i, 3020i and 3090Ci should have the foam bung inside the port tube and set to "small" and a crossover of 80Hz on the AV amplifier. Whereas, the 3050i should be set to "large" without a foam bung and does not require a crossover setting. Finally, set the distance (or delay) setting that is correct for the subwoofer position you have chosen.

Multi-Channel AV System

Play some stereo music you are familiar with and experiment with the Phase invert setting and level control until you hear a seamless blend between the front speakers and the subwoofer. If you can hear the subwoofer standing out it's too loud!

Always bear in mind that the human ear sensitivity to bass varies enormously with the volume level, hence the need for a wide range of programme material and sound levels.

Many Home Theatre amplifiers have distance settings which build in a time delay depending on the distance of the speaker from the optimum listening position; the sweet spot. The location of the subwoofer is one of the most important aspects of any Home Theatre system therefore getting these settings correct will give a significant improvement to the system's overall performance.

Do not adjust to more than +/-0.5m from the original measured distance. If it has not been possible to discern any improvement in the tone, try swapping the phase invert switch position on the 3060S Subwoofer and repeat the exercise. Then re-check the sound with some stereo music again to make sure an improvement has been noticed.

If the 3060S Subwoofer is subsequently moved relative to the other speakers reset the amplifier subwoofer distance setting to the new value and repeat the exercise. Once you are happy the optimum setting has been achieved. The sound should be full and warm and integrated with no individual speaker being dominant.

Dolby Atmos

The dimension of height and hearing sounds coming from above is key to the multi-dimensional Dolby Atmos experience. We don't support the concept of upward firing speakers for Dolby Atmos, but have an excellent range of in-ceiling speakers for this. Many home cinema installations currently have speaker systems with a subwoofer and either five or seven speakers positioned at about ear level. Overhead speakers should complement the frequency response, output, and power-handling capabilities of the ear level speakers. You should choose overhead speakers that are timbre matched as closely as possible to the listener-level speakers. Overhead speakers with a wide dispersion pattern are desirable for use in a Dolby Atmos system to ensure the closest replication of the cinematic environment.

The high power handling, wide bandwidth and swivel tweeters make the Q Acoustics Install range particularly suitable for overhead in-ceiling use.

Multi-Channel AV System

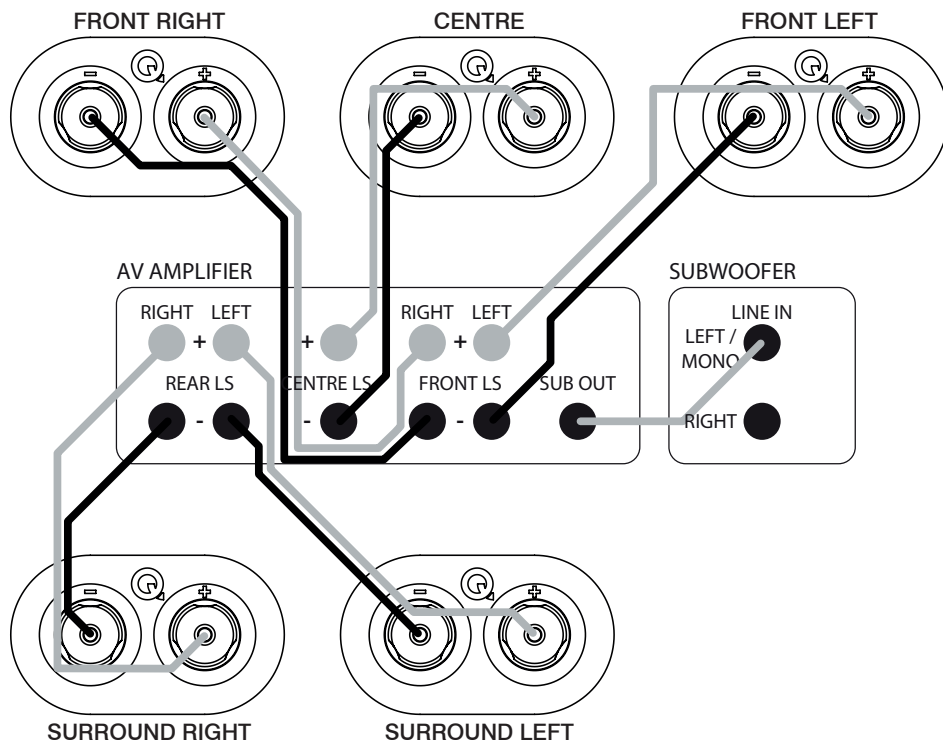

When running loudspeaker cables be especially careful not to run them across open floor areas where they could be a source of danger. Run loudspeaker cables around room boundaries whenever possible. Line level signal cables should be run away from mains cables. Never run line level signal cables parallel to power cables especially on long runs.

If the subwoofer is triggered on by appliances switching on and off, re-route the input signal cable before taking further measures.

Placement: The Front and Centre speakers should be in line. If this is not possible, consult your processor manual for guidance on adjusting relative centre / front delay times. If you have a 5.1 system, the listening seat can be closer to the rear wall. As always, be prepared to experiment.

Bass Management:

AV processors offer the choice of 'Large' or 'Small' for the speakers. If you choose 'Large' the speaker receives the full frequency. Choose 'Small' and the bass is sent to the Subwoofer. We recommend you choose 'Small' for the 3090Ci and the 3010i and 3020i wherever they are used in the system. The 3050i should be set to 'Large'. The subwoofer option should be enabled (set to 'ON' or 'YES')

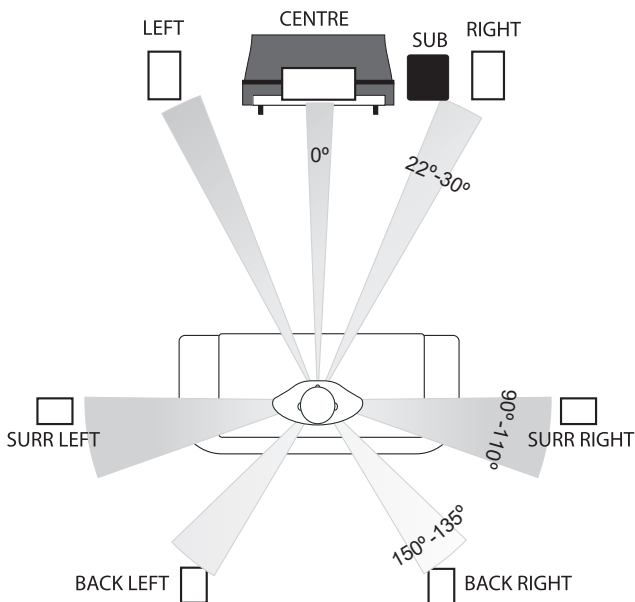

Above is the Dolby Labs recommended layout for 7.1 systems. The 6.1 layout is the same except a single central speaker replaces the two back units. The 5.1 layout has no back speakers

Levels: When the basic system parameters have been established, put your processor into the 'setup' routine. Set up each individual speaker so that the level is the same at the listening position as all the others. If your processor enables you to adjust the delay times, follow the instructions closely as this will profoundly affect the final result. When you play a movie you may think the rear channels are too soft - they aren't! You may however have to adjust the subwoofer level both at the processor and at the subwoofer. Once set, do not re-adjust these levels.

LFE: The LFE channel sends all the bass sound effects to the subwoofer. If speakers are set to 'Small', system bass from those channels is also sent to the subwoofer. If you play the system at extreme levels and / or have the subwoofer level set too high you may overdrive the subwoofer with unpleasant sonic results. If this occurs, reduce the level immediately.

Phase: If your speakers are incorrectly wired the bass will be blurred and thin. In this case, check the wiring carefully. If your speaker wire has a tracer along one core, consistently use the striped core to connect all the positive (RED) terminals. In this way the system will always be in phase.

Always follow the instructions in your AV processor manual!

Stereo System

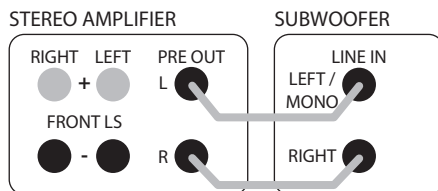

Connect a good quality stereo RCA phono lead to the L and R inputs on the 3060S and connect the other end to the PRE OUT sockets on the rear of the amplifier.

The subwoofer will automatically add the L and R signals together so that no information is missed. If you wish to use two subwoofers then you can run a single RCA phono cable to each subwoofer and thus have a stereo subwoofer system.

Ensure that the L output on the amplifier goes to the left hand side subwoofer and R to the right hand side to preserve the stereo image of the main speakers. The subwoofers will need to be placed close to their respective main speakers and the set-up will need to be done separately for each subwoofer.

Stereo System

Setting Up

Check that all system connections are properly and securely made. Ensure that the subwoofer is switched off. Set the controls to the following default settings:

Level	Approximately half
Crossover	Minimum (50Hz) for large floorstanders and halfway (100Hz) for bookshelf or small speakers
Phase invert	0°
Auto on	AUTO or ON

Plug the supplied power cord into the subwoofer and then into the AC supply socket. Switch on the power at the supply socket and then switch the power switch on the subwoofer to 'ON'. The POWER light on the subwoofer amplifier panel will glow and the subwoofer is operational.

Play some music you are familiar with and experiment with the Phase invert setting and level control until you hear a good blend between the front speakers and the subwoofer. If you can hear the subwoofer standing out it's too loud!

Always bear in mind that the human ear's sensitivity to bass varies enormously with the volume level, hence the need for a wide range of programme material and sound levels. Once you are happy with the sound you can then fine tune the performance by using the remaining controls.

Crossover: The crossover control determines at what frequency your subwoofer output begins to rapidly diminish. This should be set so that it corresponds with the frequency your main speakers begin to produce a strong output by themselves. The adjustment allows for a smooth handing over between subwoofer and main speaker output. If this setting is too low there will be a 'hole' in the sound where certain frequencies are weak, conversely if it is too high there will be an exaggeration of certain frequencies producing an overpowering bass. You can get an idea of the correct setting from your main speakers specification sheet, look for the lowest frequency that the speaker produces (the "-3dB point") under the "Frequency response" heading. Room positioning has a dramatic effect on low frequency reproduction of both the subwoofer and your main speakers so don't be worried if you find you require a setting which does not correlate with the specified low frequency point of your main speakers.

Aftercare

Cabinet Care



Clean cabinets only with a lightly dampened cloth. Do not use solvent based cleaning materials. Never use abrasives of any kind.

The cabinet surfaces will usually only require light dusting. Should an aerosol or other cleaner be used, apply the cleaner onto the cloth first and not directly onto the product. Test a small area first, as some cleaning products may damage the finish. Avoid products that are abrasive, or contain acid or alkaline agents. Do not use any cleaning materials on the drive units and avoid touching them as damage may result.

Grilles

Grilles should only be cleaned using a soft brush when necessary.



If using the Q Acoustics speaker with the grilles removed, remember to replace them if pets or children are present.

Drive Units

Do not touch the drive units as they are easily damaged when exposed.

Warranty

Q Acoustics passive loudspeaker products are warranted free of defects in materials and workmanship for a period of 4 years (1 year for subwoofer) from the date of purchase. During the warranty period Q Acoustics will, at its option, repair or replace any product found to be faulty after inspection by the company or its appointed distributor or agent.

Misuse and fair wear and tear are not covered by warranty.

Goods for repair should in the first instance be returned to the supplying dealer. If this is not possible contact Q Acoustics or their appointed distributor for your area to determine the correct warranty procedure. If possible the original packaging should be used to return the product as damage sustained during transit to the repair centre is not covered by the warranty. The warranty does not in any way affect your legal rights.

Warranty can be extended to 5 years (2 years for subwoofer) by registering your product at www.qacoustics.co.uk/register.

For service information contact: info@qacoustics.co.uk

Q Acoustics
Stortford Hall Industrial Park
Bishops Stortford, Herts, UK
CM23 5GZ

Accessories

Wall Bracket (Single)
 3010i / 3020i / 3090Ci
 Black and White

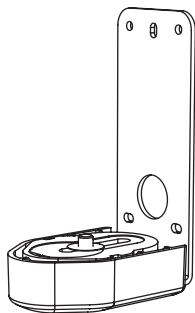

Dimensions (WxHxD): 70 x 159 x 99 mm

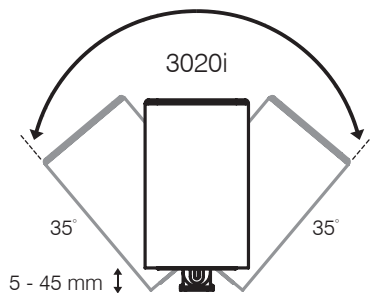
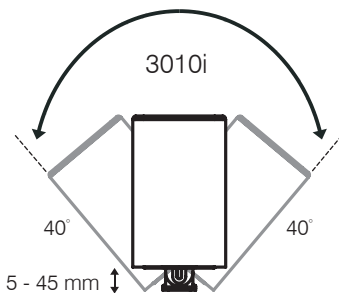
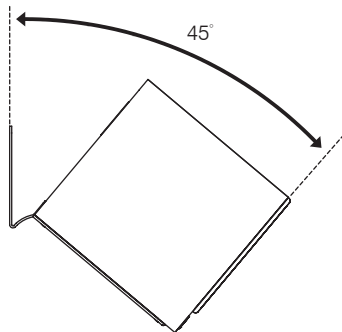

Speaker Stand (Pair)
 3010i / 3020i
 Black and White

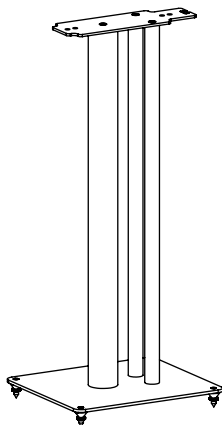

Dimensions (WxHxD): 250 x 682 x 290 mm

Subwoofer Wall Bracket
 3060S
 Black

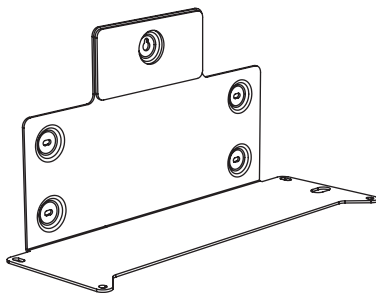

Dimensions (WxHxD): 422 x 222 x 163 mm

Specifications

Passive Loudspeakers

Enclosure type:	3010i 2-way reflex	3020i 2-way reflex
Bass unit:	100 mm (4.0 in)	125 mm (5.0 in)
Treble unit:	22 mm (0.9 in)	22 mm (0.9 in)
Frequency response (+3 dB, -6 dB):	65 Hz - 30 kHz	64 Hz - 30 kHz
Average impedance:	6 Ω	6 Ω
Minimum impedance:	4 Ω	4 Ω
Sensitivity (2.83v@1m):	86 dB	88 dB
Stereo amplifier power:	15 - 75 W	25 - 75 W
AV receiver power (2 ch. driven):	50 - 125 W	50 - 125 W
Crossover frequency:	2.6 kHz	2.4 kHz
Effective volume:	4.0 L (244 cu in)	6.1 L (372 cu in)
Enclosure dimensions (WxHxD): (inc. grille, terminal and feet)	150 x 253 x 252 mm (5.9 x 10.0 x 10.0 in)	170 x 278 x 282 mm (6.7 x 11.0 x 11.1 in)
Enclosure width:		
Weight (per speaker):	4.1 kg (9.0 lbs)	5.5 kg (12.1 lbs)

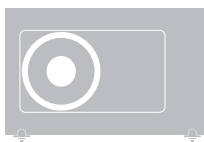

Active Subwoofer

Enclosure type:	3060S Infinite baffle
Bass unit:	200 mm (8.0 in)
Amplifier power:	150 W Class-D
Frequency response (+3 dB, -6 dB):	35 Hz - 250 Hz
Crossover frequency:	35 Hz - 250 Hz (var.)
Effective volume:	10.6 L (647 cu in)
Enclosure dimensions (WxHxD):	480 x 300 x 150 mm (18.9 x 11.8 x 5.9 in) 324 mm (12.7 in) inc. spikes
Weight:	8.5 kg (18.7 lbs)

**3050i**

2-way reflex

2 x 165 mm (6.5 in)

22 mm (0.9 in)

44 Hz - 30 kHz

6 Ω

4 Ω

91 dB

25 - 180 W

50 - 165 W

2.5 kHz

32.4 L (1977 cu in)

310 x 1020 x 310 mm

(12.2 x 40.1 x 12.2 in)

200 mm (7.9 in)

17.8 kg (39.2 lbs)

**3090Ci**

2-way reflex

2 x 100 mm (4.0 in)

22 mm (0.9 in)

75 Hz - 30 kHz

6 Ω

4 Ω

89 dB

25 - 100 W

50 - 165 W

2.7 kHz

6.6 L (403 cu in)

430 x 152 x 216 mm

(16.9 x 6.0 x 8.5 in)

6.0 kg (13.2 lbs)