

Installation

WF2605

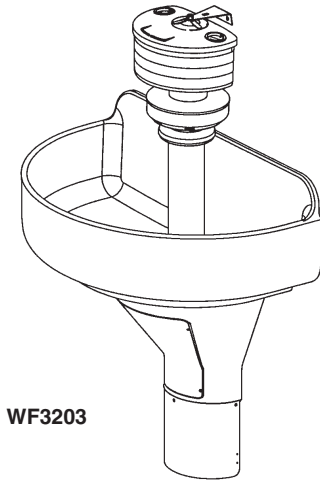
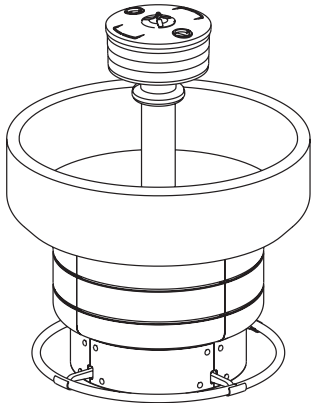

WF3203

WF2500 Series Terreon Classic
WF2600 Series Terrazzo
WF2700 Series Stainless Steel
WF2800 Series Bradstone
WF3200 Series Terreon Deep Bowl
TDB3100 Series Terreon Deep Bowl



Read the instructions in this manual before beginning installation. Save these instructions and refer to them for inspection, maintenance and troubleshooting information.

For questions regarding the operation, installation or maintenance of this product, visit bradleycorp.com or call 800.BRADLEY (800.272.3539).

Product warranties and parts information may also be found under "Products" on our website at bradleycorp.com.

Separate parts from packaging and make sure all parts are accounted for before discarding any packaging material. If any parts are missing, do not begin installation until you obtain the missing parts.





Safety Information

Installation

Turn OFF electrical supply to the unit before installation.

Compliance and conformity to drain requirements and other local codes and ordinances is the responsibility of the installer.

Proper installation in compliance with industry and government standards for metering faucets requires the following:

1. Adjust volume control until water spray strikes bottom of bowl, 4-inches in from the rim.
2. Air valve metering timing is factory pre-set.

Failure to follow these instructions may negatively affect energy and water use efficiency.

Product/Property Damage

Make sure that all water supply lines have been flushed and then completely turned off before beginning installation. Debris in the supply lines can cause valves to malfunction.



Cleaning and Maintenance for Terreon®

Material Description: Terreon is a densified solid surface material composed of bio based resin and is resistant to chemicals, stains, burns and impact. Surface can be easily repaired with everyday cleansers or fine grit abrasives. Because Terreon is a unique cast material, its aggregate flow and distribution, and shades of color can vary from product to product creating natural characteristics.

Routine Cleaning: For regular cleaning, use mild neutral base cleaners.

Stubborn Stains: Remove tough stains with Soft-Scrub® and a green Scotch-Brite® pad or lightly sand in a circular motion with 240 grit wet/dry sandpaper. The finish can then be renewed with a maroon Scotch-Brite pad.

Scratches: Remove scratches with a green Scotch-Brite pad. The finish can then be renewed with a maroon Scotch-Brite pad.

Hard Water Deposits: Remove hard water deposits with a mild solution of vinegar and water. Always rinse the unit thoroughly after cleaning.

Restoring the surface: Use Hope's® Perfect Countertop to refresh and protect the Terreon Solid Surface material. Dark Terreon colors may require additional care and maintenance. For complete instructions on this additional maintenance, visit bradleycorp.com.

Repair Kits: Terreon repair kits are available. Contact your Bradley representative or distributor for part numbers and pricing. Repair kits are made to order and have a shelf life of 30 days.

NOTICE! Do not use strong acid or alkaline chemicals and cleaners to clean Terreon. If these chemicals come in contact with the surface, wipe them off immediately and rinse with soapy water. Avoid contact with harsh chemicals such as paint remover, bleach, acetone, etc. Avoid contact with hot pans and objects.

Cleaning and Maintenance for Stainless Steel

Material Description: Stainless steel is extremely durable, and maintenance is simple and inexpensive. Proper care, particularly under corrosive conditions, is essential. Always start with the simplest solution and work your way toward the more complicated.

Routine cleaning: Daily or as often as needed use a solution of warm water and soap, detergent, or ammonia. Apply the cleaning solution per the manufacturer's instructions and always use a soft cloth or sponge to avoid damaging the finish.

Stubborn Stains: To remove stains from stainless steel use a stainless steel cleaner and polish such as Ball® stainless steel cleaner or a soft abrasive. Always follow the manufacturer's instructions and apply in the same direction as the polish lines.

NOTICE! Never use ordinary steel wool or steel brushes on stainless steel. Always use stainless steel wool or stainless steel brushes.

Fingerprints and Smears: To remove fingerprints or smears use a high quality stainless steel cleaner and polish in accordance with the manufacturer's instructions. Many of these products leave a protective coating that helps prevent future smears and fingerprints.

Grease and Oil: To remove grease and oil use a quality commercial detergent or caustic cleaner. Apply in accordance to the manufacturer's instructions and in the direction of the polish lines.

Precautions: Avoid prolonged contact with chlorides (bleaches, salts), bromides (sanitizing agents), thiocyanates (pesticides, photography chemicals, and some foods), and iodides on stainless steel equipment, especially if acid conditions exist.

NOTICE! Do not permit salty solutions to evaporate and dry on stainless steel.

The appearance of rust streaks on stainless steel leads to the belief that the stainless steel is rusting. Look for the actual source of the rust in some iron or steel particles which may be touching, but not actually a part of the stainless steel structure.

NOTICE! Strongly acidic or caustic cleaners may attack the steel causing a reddish film to appear. The use of these cleaners should be avoided.



Cleaning and Maintenance for Terrazzo

Material Description: Terrazzo is a mosaic-looking natural stone and concrete material polished to a high gloss and sealed with clear polyurethane resin for long lasting beauty. Terrazzo is precast and composed of 85% stone and 15% binder with steel reinforcing rods cast into the bowl.

Routine Cleaning: Clean daily or as often as conditions require with any standard detergent, warm water and a soft cloth.

Stubborn Stains: If stains have permeated the surface of the terrazzo, follow instructions for restoring the surface listed below.

Restoring the surface: Use paint stripper to remove the existing polyurethane (it is important to remove all of the old polyurethane to ensure a high quality finish). Then use light grit sand paper to remove any stubborn stains that have permeated the surface. Clean and thoroughly dry the bowl. Then apply 2 to 3 coats of polyurethane to the terrazzo in accordance with the manufacturer's instructions. Allow the polyurethane to dry completely per the manufacturer's recommendations before turning on the water.

NOTICE! If the bowl is not completely dry before applying the polyurethane, the polyurethane will not adhere to the surface.

NOTICE! Make sure the surface is completely covered with polyurethane to prevent water from penetrating the surface and damaging the terrazzo.

Repair Kits: Terrazzo repair kits are available. Contact your Bradley representative or distributor for part numbers and pricing.

NOTICE! Do not place acid or alkaline solutions (floor stripper or drain cleaners) into the terrazzo bowl or use them to clean the bowl. If these solutions come into contact with the terrazzo, rinse the bowl immediately with water and inspect for damage. If damage has occurred, follow the directions for restoring the surface. If bowl begins to haze, it is usually a sign that the terrazzo has come into contact with an acid or alkaline chemical or has been exposed to UV radiation. To repair this condition, follow the instructions for restoring the surface.

Cleaning and Maintenance for Bradstone

Material Description: Bradstone is an extremely durable plastic material made of reinforced thermosetting polyester resins, finely ground inorganic fillers and fade resistant pigments. Bradstone is impervious to most chemicals and stains.

Routine Cleaning: Soap and dirt accumulations should be washed off with detergent cleaners. Abrasive and caustic cleaners are not recommended. An occasional waxing with automotive wax will make future cleaning even easier.

Brand Names

Use of brand names is intended only to indicate a type of cleaner. This does not constitute an endorsement, nor does the omission of any brand name cleaner imply inadequacy. Many products named are regional in distribution, and can be found in local supermarkets, department and hardware stores, or through your cleaning service. It is emphasized that all products should be used in strict accordance with package instructions.



Circular Bowl and Pedestal Assembly (Terreon® and Bradstone®) WF2505, WF2508, WF2805, WF2808

P.O. Box 309 • Menomonee Falls, WI 53052-0309 • 1 800 BRADLEY • 262 251 6000 • bradleycorp.com



This document describes installation of washfountain bowl and pedestal only. Terreon Classic and Bradstone washfountains are shipped partially pre-assembled. Some optional equipment and accessories are shown for clarity. For activation, optional equipment and accessory installation, see installation documents included with those parts.



Before installation of bowl and pedestal assemblies, review all included instructions. Some options may require additional steps during the bowl and pedestal installation process.

Supplies Required by Installer

- (8) 1/2" lag bolts, screws or other fasteners to anchor washfountain pedestal to floor
- 1" hot and cold water or tempered supply lines and fittings (see activation instructions)
- Reducing fittings and 1/2" nom. copper tubing supply lines for types with supplies from above (see activation instructions)
- Standard P-trap (vented trap supplied by Bradley when required)
- 2" drain lines and fittings (see activation instructions)
- 1-1/2" vent pipe on types vented through washfountain column
- Pipe sealant and plumber's putty



Supply lines for one or two washfountains should be 1"; for three washfountains 1-1/4"; for more than three washfountains, pipe size should increase proportionally. Vent pipe to be 1-1/2" on models vented through washfountain.



Valving installations for Classic washfountains require rigid plumbing installation and connections to ensure proper operation and support of the valve assemblies, especially for foot control activated washfountains. Do not use flexible supply hoses unless specified in your activation instruction documentation and supplied with your washfountain.



Circular Bowl and Pedestal Assembly (Terreon® and Bradstone®) WF2505, WF2508, WF2805, WF2808

P.O. Box 309 • Menomonee Falls, WI 53052-0309 • 1 800 BRADLEY • 262 251 6000 • bradleycorp.com

Circular Washfountain Dimensions

(mm)

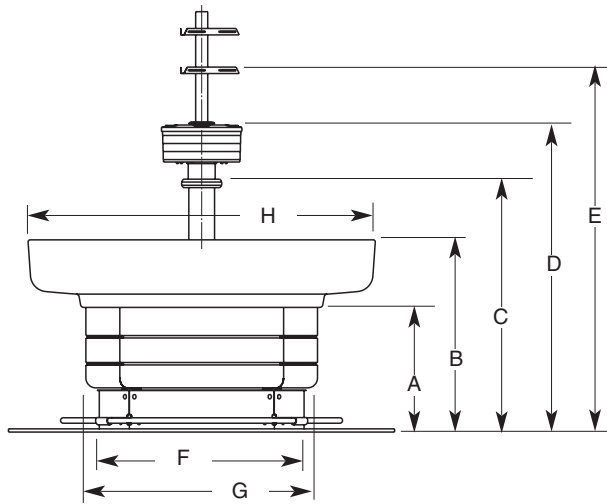

Approximate Dimensions in Inches*

| Material | Size | A | B | C | D | E | F | G | H |
|-----------|------|--------|--------|--------|--------|--------|----|----|----|
| Terreon | 54" | 19 | 29-1/2 | 38-3/4 | 47-1/4 | 55-3/4 | 32 | 36 | 54 |
| Terreon | 36" | 19 | 29-1/2 | 35-1/4 | 43-1/4 | 52-1/4 | 21 | 25 | 36 |
| Bradstone | 54" | 19-3/4 | 29-1/4 | 37-1/2 | 46 | 54-3/8 | 32 | 36 | 54 |
| Bradstone | 36" | 19-3/4 | 29-1/4 | 34 | 42-1/2 | 50-7/8 | 21 | 25 | 36 |

* Subtract 4" from dimensions A through E for juvenile height. Bradstone not available in juvenile height.

Approximate Dimensions in Millimeters*

| Material | Size | A | B | C | D | E | F | G | H |
|-----------|--------|-----|-----|-----|------|------|-----|-----|------|
| Terreon | 1372mm | 483 | 749 | 984 | 1200 | 1416 | 813 | 914 | 1372 |
| Terreon | 914mm | 483 | 749 | 895 | 1099 | 1327 | 533 | 635 | 914 |
| Bradstone | 1372mm | 502 | 743 | 953 | 1168 | 1381 | 813 | 914 | 1372 |
| Bradstone | 914mm | 502 | 743 | 864 | 1080 | 1292 | 533 | 963 | 914 |

* Subtract 102mm from dimensions A through E for juvenile height. Bradstone not available in juvenile height.



Length of Tie Pipe Required for Vent Through Washfountain Column

| Type | Pipe Length |
|--|------------------|
| 54" Less Soap Dispenser | 21-1/2" (543mm) |
| 36" Less Soap Dispenser | 18" (457mm) |
| 54" with Soap Dispenser | 30" (762mm) |
| 36" with Soap Dispenser | 26-1/2" (673) |
| 54" Less Soap Dispenser with Towel Dispenser | 55-1/2" (1410mm) |
| 36" Less Soap Dispenser with Towel Dispenser | 52" (1321mm) |
| 54" with Soap Dispenser with Towel Dispenser | 48" (1213mm) |
| 36" with Soap Dispenser with Towel Dispenser | 44-1/2" (1130mm) |
| 54" with Cube Adapter | 32" (813mm) |
| 36" with Cube Adapter | 28-1/2" (724mm) |
| 54" with Cube Adapter with Towel Dispenser | 50" (1270mm) |
| 36" with Cube Adapter with Towel Dispenser | 46-1/2" (1181mm) |
| 54" with Cube Adapter and Soap Dispenser | 40" (1016mm) |
| 36" with Cube Adapter and Soap Dispenser | 36-1/2" (927mm) |



Drain must be connected with 2" schedule 40 welded wrought iron pipe, minimum, to provide lower support for this installation. Vent or support pipe must be of the same material in 1-1/2". For detailed tie pipe information, see 215-1834-26.



Circular Bowl and Pedestal Assembly (Terreon® and Bradstone®) WF2505, WF2508, WF2805, WF2808

P.O. Box 309 • Menomonee Falls, WI 53052-0309 • 1 800 BRADLEY • 262 251 6000 • bradleycorp.com

Rough-In Specifications

(mm)

Type A

Off-line vent with
supplies from below

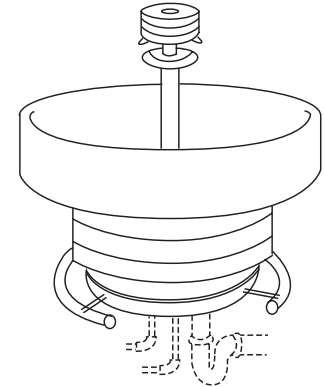
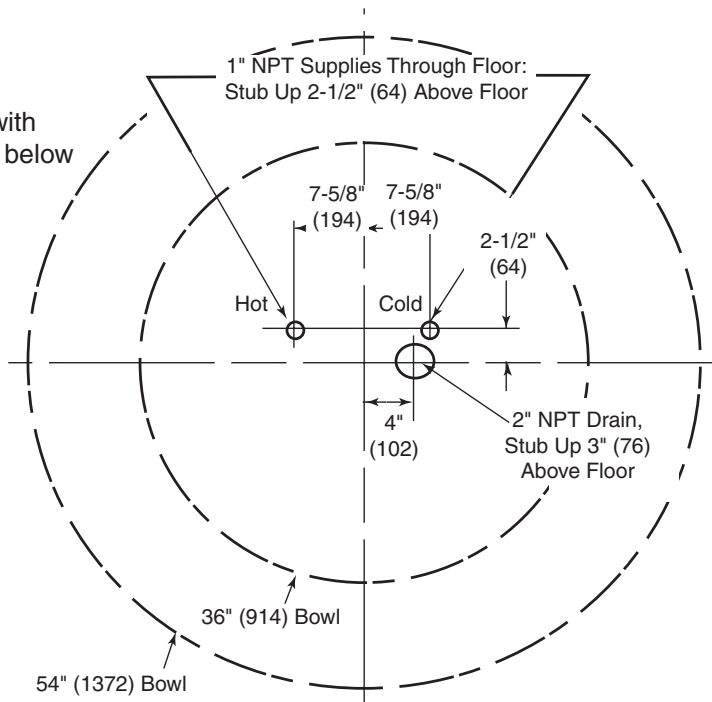

UPC and IPC restricts the vertical distance from the fixture outlet to the trap weir to not more than 24". Check state and local codes for variances.



Some optional equipment shown.

Type B

Centrally rising vent with
supplies from above

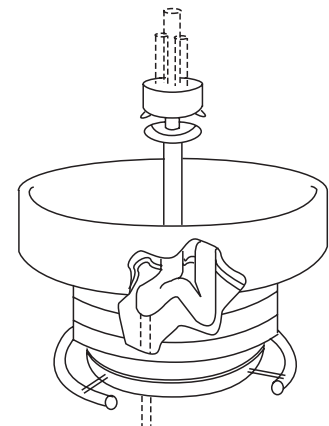
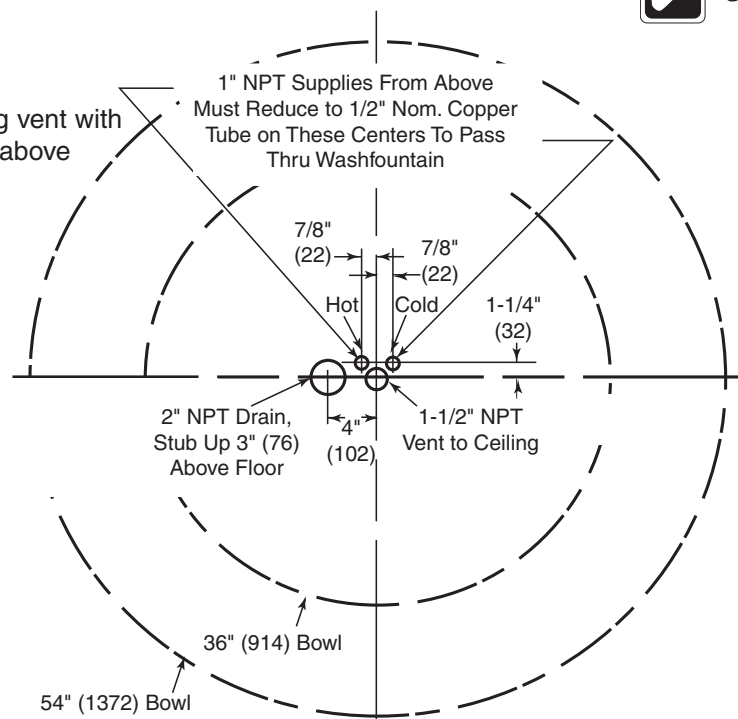

Rough-In Notes

1. All pipes and fittings not furnished by Bradley are shown in broken lines.
2. Supply lines for one to two washfountains should be 1", for three washfountains 1-1/2"; for more than three washfountains, pipe sizes should be increased proportionately.
3. Overhead supplies must be reduced to 1/2" copper tube to pass through support tube.
4. Check valve inlets are 1/2" NPT.



Circular Bowl and Pedestal Assembly (Terreon® and Bradstone®) WF2505, WF2508, WF2805, WF2808

P.O. Box 309 • Menomonee Falls, WI 53052-0309 • 1 800 BRADLEY • 262 251 6000 • bradleycorp.com

Rough-In Specifications

(mm)

Type O

Off-line vent with supplies from above

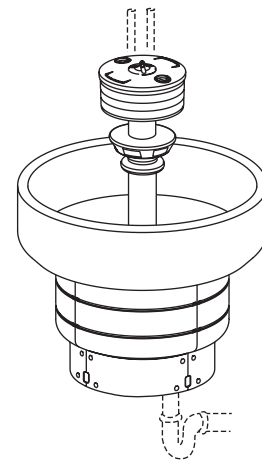
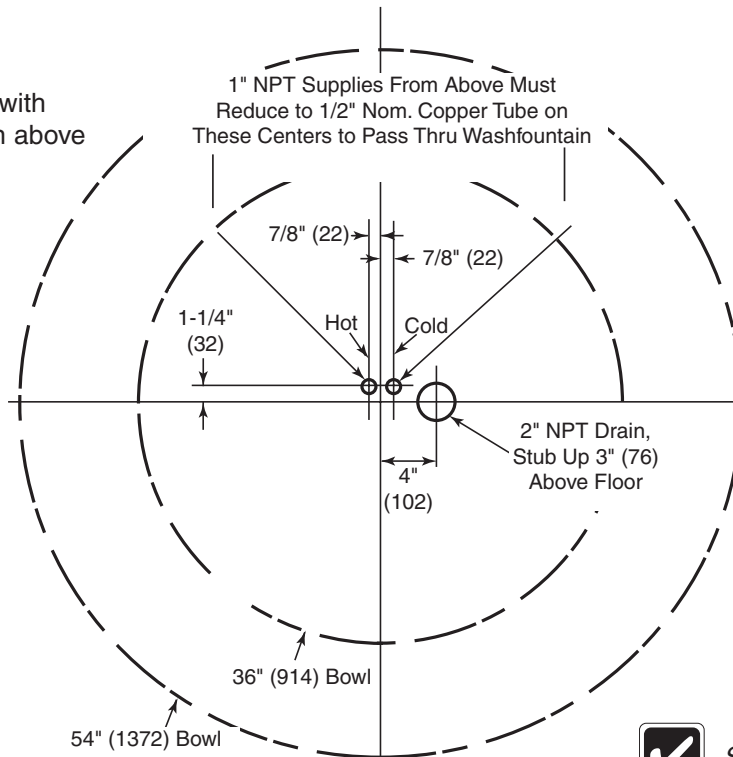

UPC and IPC restricts the vertical distance from the fixture outlet to the trap weir to not more than 24". Check state and local codes for variances.



Some optional equipment shown.

Type H

Centrally rising vent with supplies from below

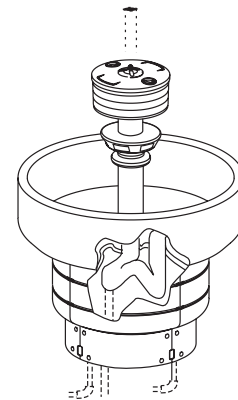
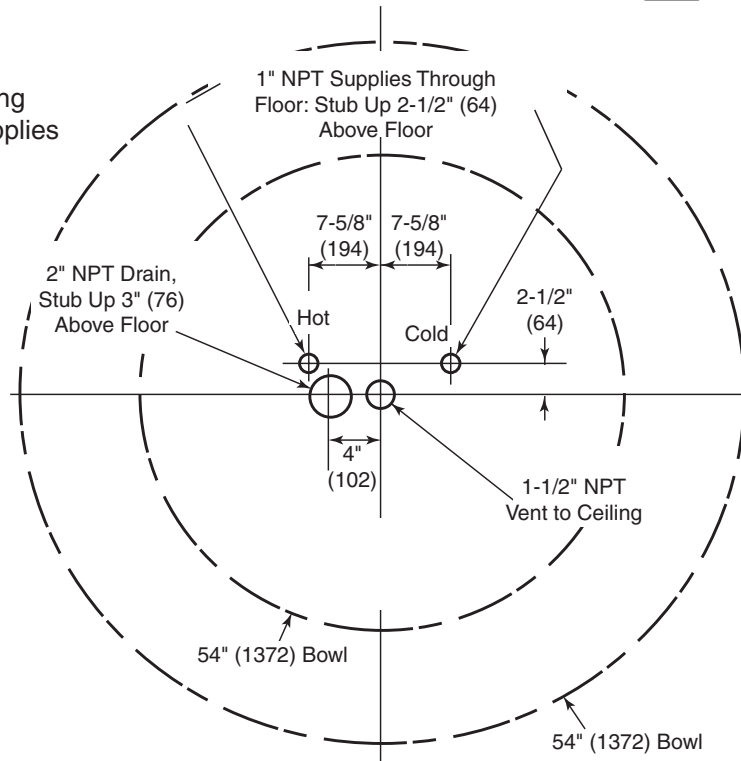

Rough-In Notes

1. All pipes and fittings not furnished by Bradley are shown in broken lines.
2. Supply lines for one to two washfountains should be 1", for three washfountains 1-1/2"; for more than three washfountains, pipe sizes should be increased proportionately.
3. Overhead supplies must be reduced to 1/2" copper tube to pass through support tube.
4. Check valve inlets are 1/2" NPT.



Circular Bowl and Pedestal Assembly (Terreon® and Bradstone®) WF2505, WF2508, WF2805, WF2808

P.O. Box 309 • Menomonee Falls, WI 53052-0309 • 1 800 BRADLEY • 262 251 6000 • bradleycorp.com

1 Installing the Drain

A Rough in supply and drain piping as required for your installation.

B Assemble the drain to the dimension shown below for the bowl size you are installing.



All piping shown in dotted lines to be supplied by installer.

Types A and O

2" NPT Coupling if Tie Pipe is not required (Supplied by Installer)

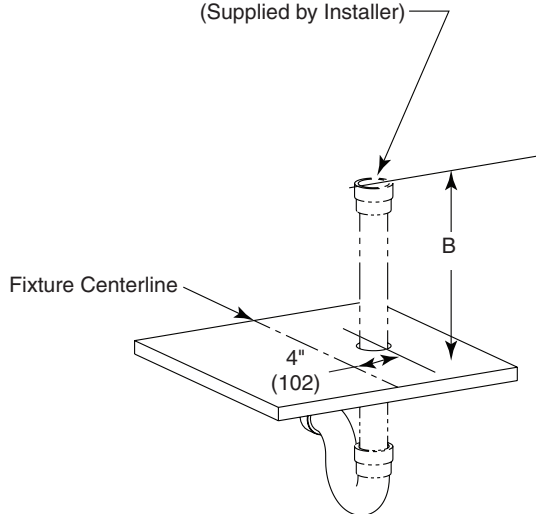

Types B and H

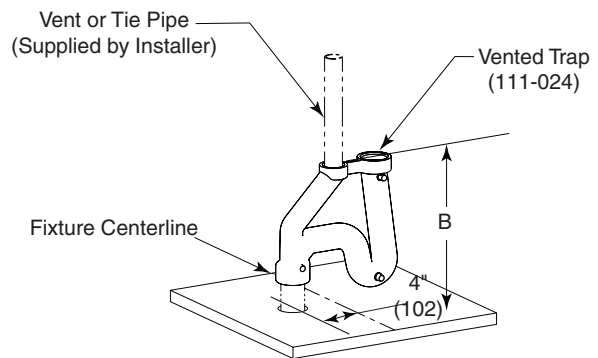

Vent or Tie Pipe (Supplied by Installer)

Optional Tie Pipe Bracket (S70-082)

Types A and O With Tie Pipe Bracket Option

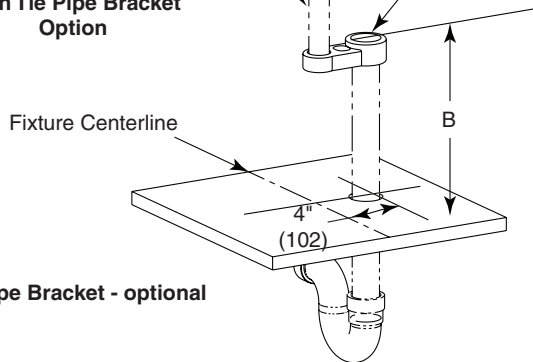

Tie Pipe Bracket - optional

Trap Dimensions (mm)

| Bowl Material | Size | Dim | Standard Height | Juvenile Height |
|---------------|------|-----|-----------------|-----------------|
| Terreon | 36" | B | 18-5/8 (473) | 14-5/8" (371) |
| Terreon | 54" | B | 18-5/8" (473) | 14-5/8" (371) |
| Bradstone* | 36" | B | 17-3/8" (441) | N/A* |
| Bradstone* | 54" | B | 17" (432) | N/A* |

* Bradstone is not available in juvenile height.



Circular Bowl and Pedestal Assembly (Terreon® and Bradstone®) WF2505, WF2508, WF2805, WF2808

P.O. Box 309 • Menomonee Falls, WI 53052-0309 • 1 800 BRADLEY • 262 251 6000 • bradleycorp.com

3 Bowl Assembly and Mounting

NOTICE! The pedestal must be level when secured to floor for proper drainage.

CAUTION! Use suitable lifting equipment to position bowl and pedestal assembly. Handle with care! Failure to do so could result in serious personal injuries.

A Position the bowl and pedestal assembly so that the bowl drain is in line with the trap or drain line.

B Drop the spud into the drain to ensure correct alignment.

C Level the bowl, if required, by placing washers under the legs. Check fit against the wall and adjust if necessary by loosening the screws attaching the bowl to the pedestal.

E Anchor the pedestal to the floor with suitable fasteners (supplied by installer).

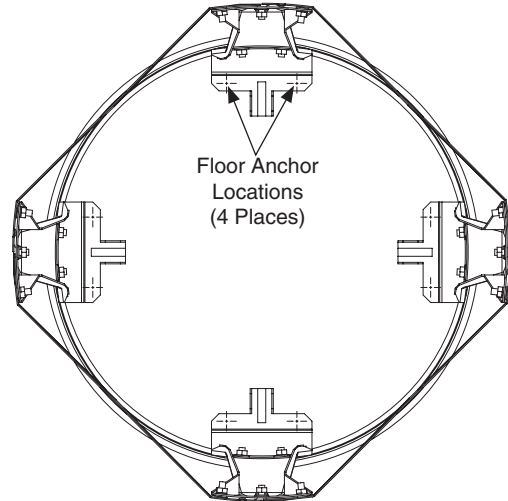

Some optional equipment shown.

4 Installing Drain Spud in Bowl

A Secure drain spud with lock nut and washers as shown.

 Seal between drain spud and drain hole with plumber's putty (supplied by installer).

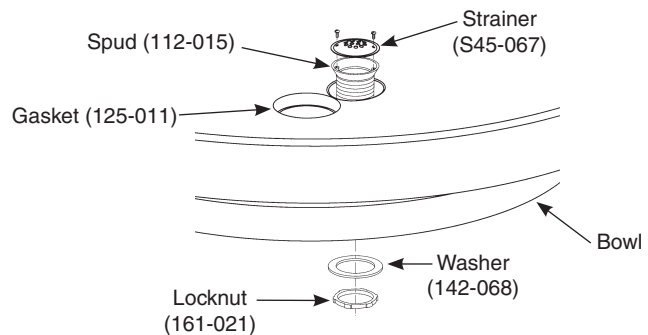



Non-Sectional Sprayhead



Repair kit does not include sprayhead grommet. Order as a separate item.

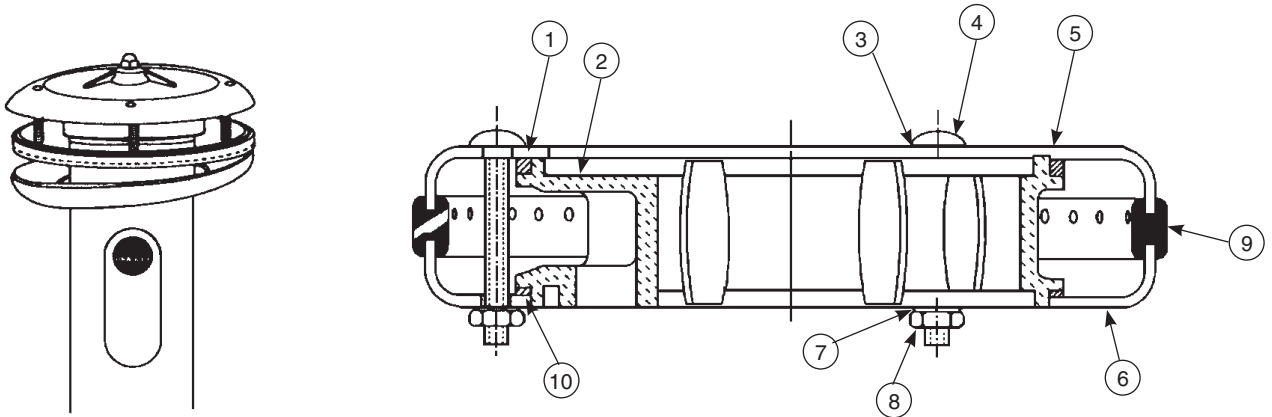

Parts List

| Item | Part No. | Description | Sprayhead Assembly | Repair Kit S45-051 |
|------|-----------|---------------------------------|--------------------|--------------------|
| | | | Qty | |
| 1 | 125-001DE | Neoprene Washer - Top | 1 | 1 |
| 2 | 139-031 | Sprayhead Manifold | 1 | - |
| 3 | 124-001AL | Washer | 3 | 4 |
| 4 | 160-211 | Carriage Bolt | 3 | 4 |
| 5 | 115-061 | Sprayhead Top | 1 | - |
| 6 | 116-008 | Sprayhead Bottom | 1 | - |
| 7 | 124-001AT | Washer | 3 | 4 |
| 8 | 161-025 | Nut | 3 | 4 |
| 9 | 124-020C | Sprayhead Grommet - Circle | 1 | - |
| 9 | 120-020D | Sprayhead Grommet - Semi-Circle | 1 | - |
| 9 | 120-020E | Sprayhead Grommet - Corner | 1 | - |
| 10 | 125-001DF | Neoprene Washer - Bottom | 1 | 1 |



Sprayhead Troubleshooting

| Problem | Cause | Solution |
|---|---|---|
| Water splashes over the rim of the bowl. | Foreign matter has reduced the size of the sprayhead slots, causing greater pressure at the open slots. | <p>Clean the sprayhead:</p> <ol style="list-style-type: none"> 1. Disassemble the sprayhead and dislodge any dirt, lime build-up and foreign debris with a wire brush. 2. Sprayheads with rubber grommet spray rings may be cleaned by rubbing a coin over the grommet. <p>Throttle down the volume control (water spray should strike the bowl without splashing outside of the bowl).</p> |
| Water flow diminishes from the sprayhead. | Strainer portion of the stop-strainer-check valve is plugged. | <p>Remove and clean the strainer screen from the stop-strainer-check valve.</p> <p> <i>The non-sectional sprayhead includes a perforated neoprene spray ring grommet that is self-cleaning. The water pressure flexes the spray holes which slows accumulation of foreign matter and tends to "break loose" any such deposits that may have accumulated.</i></p> |

Sprayhead Tubing Connections

⚠ WARNING Flush supply lines before making connections.

A Using a sharp razor, cut tubing squarely and remove any burrs. DO NOT pinch or crush end of tubing.

B Loosen nut on fitting. Moisten end of tube and push into fitting until it is firmly seated. Tighten nut to secure tube to fitting (make sure nut is securely tightened).

C If connector leaks, reseal tubing according to above procedure. If leaking persists, replace male connector, or call a Bradley representative for assistance.

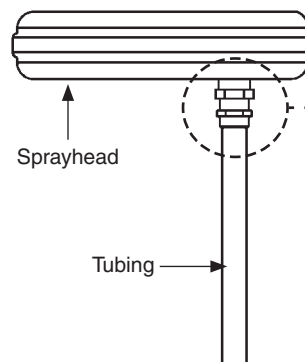
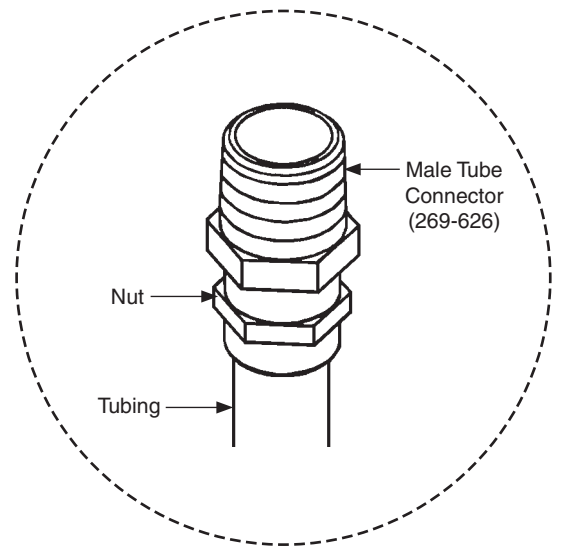



TouchTime® Activation Modules - Non-Sectional Circular Washfountains WF2505, WF2508, WF2605, WF2608, WF2705, WF2708, WF2805 & WF2808

P.O. Box 309 • Menomonee Falls, WI 53052-0309 • 1 800 BRADLEY • 262 251 6000 • bradleycorp.com

Supplies Required by Installer

- 110VAC GFI power source for 120VAC/12VDC plug in adapter
- OPTIONAL: Bradley recommends installing an electrical cutoff switch to the unit. This feature allows no accidental water delivery during regular maintenance and service.

Pre-Installation Information

TouchTime

TouchTime pushbutton/piezo switch activates a flow of water. Sprayhead is controlled by a solenoid valve, allowing user to activate a flow of tempered water from sprayhead with a pushbutton for 15 seconds. Valve uses less than half the maximum amount of hot water allowed by the ANSI/ASHRAE/ES 90A-1980 standard. Activation time can be adjusted in the field.

Solenoid Valve

An electronically controlled solenoid valve serves as the metering mechanism. Few moving parts provide reliable metering performance and the solenoid is unaffected by chemicals and minerals often present in municipal water supplies.



TouchTime® Activation Modules - Non-Sectional Circular Washfountains WF2505, WF2508, WF2605, WF2608, WF2705, WF2708, WF2805 & WF2808

P.O. Box 309 • Menomonee Falls, WI 53052-0309 • 1 800 BRADLEY • 262 251 6000 • bradleycorp.com

1a Assemble TouchTime® – A and O Units (A Shown)

- A** Install hemmed end (not sharp end) of support tube with gasket onto bowl. Connect 1/2" dia. tubing to sprayhead.
- Using a sharp razor, cut tubing squarely and remove any burrs. DO NOT pinch or crush end of tubing.
 - Loosen nut on fitting. Moisten end of tube and push into fitting until it is firmly seated. Tighten nut to secure tube to fitting (make sure nut is securely tightened).
 - If connector leaks, reseal tubing according to above procedure. If leaking persists, replace male connector, or call your Bradley representative for assistance.

- B** Place sprayhead with 1/2" tubing onto support tube. Run the tubing down through the support tube and connect to valve tube connector.

- C** Assemble the lower tie rod (the longer threaded rod), upper tie bar (notched at corners), lower tie bar, tie rod nut and coupling nut, then attach the 4-1/4" tie rod to coupling nut.

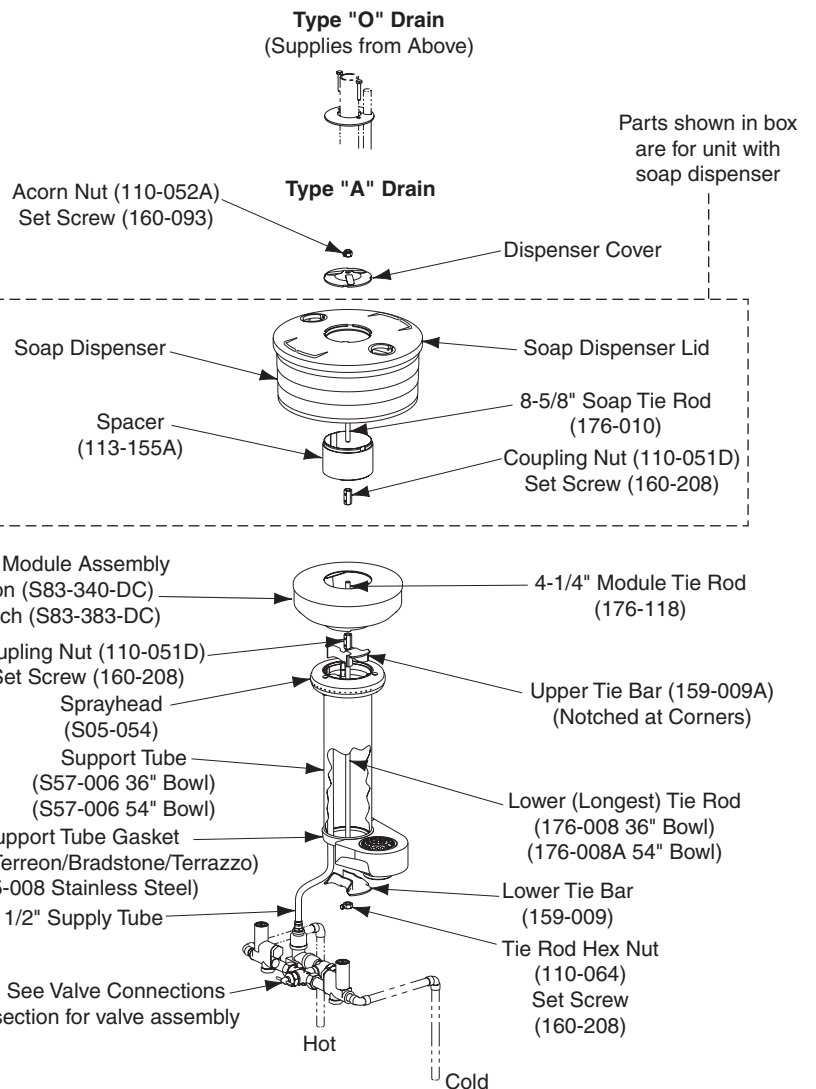
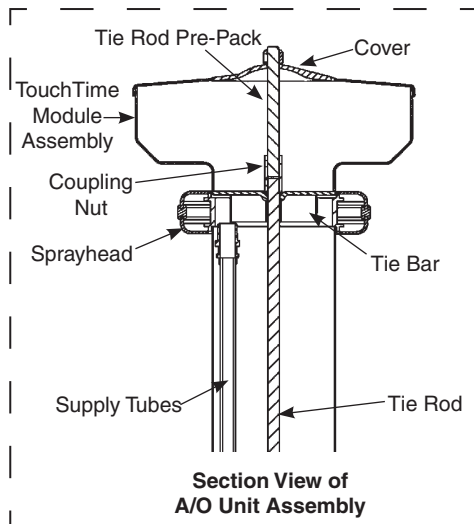

Some optional equipment shown.



TouchTime® Activation Modules - Non-Sectional Circular Washfountains WF2505, WF2508, WF2605, WF2608, WF2705, WF2708, WF2805 & WF2808

P.O. Box 309 • Menomonee Falls, WI 53052-0309 • 1 800 BRADLEY • 262 251 6000 • bradleycorp.com

1a Assemble TouchTime® – A and O Units (O Shown) (cont...)

D Place the TouchTime module assembly on top of sprayhead. Rotate until module locks in with tie bar. Run TouchTime button cables through the support tube down into the pedestal and connect to the TouchTime modules, taking care that each sprayhead section's 1/2" supply tube and TouchTime module cable are connected to the same valve (see details in Steps 2 and 3).



Skip to step F for units without soap.

E For units with soap option, install the spacer, soap dispenser and cover using coupling nut, soap tie rod (8-5/8" long) and second coupling nut as shown.

F Secure module cover and dispenser cover with acorn nut and set screw.

G Connect supply stops onto stub-outs. Connect flexible hoses to supply stops.

H **FOR O UNIT:** Install 1/2" nominal copper tubing supply lines (pass them through holes in cover down through support column) and connect to stops using suitable fittings.

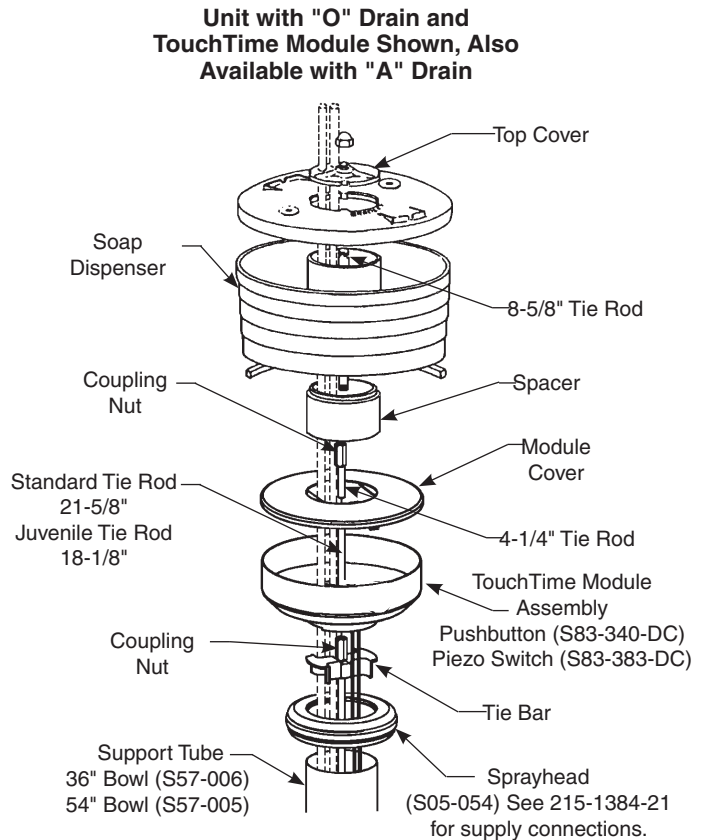

Some optional equipment shown.



TouchTime® Activation Modules - Non-Sectional Circular Washfountains WF2505, WF2508, WF2605, WF2608, WF2705, WF2708, WF2805 & WF2808

P.O. Box 309 • Menomonee Falls, WI 53052-0309 • 1 800 BRADLEY • 262 251 6000 • bradleycorp.com

1b Assemble TouchTime® – B and H Units (B Shown)

A Install hemmed end (not sharp end) of support tube with gasket onto bowl. Connect 1/2" dia. tubing to sprayhead.

- Using a sharp razor, cut tubing squarely and remove any burrs. DO NOT pinch or crush end of tubing.
- Loosen nut on fitting. Moisten end of tube and push into fitting until it is firmly seated. Tighten nut to secure tube to fitting (make sure nut is securely tightened).
- If connector leaks, reseal tubing according to above procedure. If leaking persists, replace male connector, or call your Bradley representative for assistance.

B Place sprayhead with 1/2" tubing onto support tube. Run the tubing down through the support tube and connect to valve tube connector.

C Place the TouchTime module assembly on top of sprayhead. Rotate until module locks in with tie bar. Run TouchTime button cables through the support tube down into the pedestal and connect to the TouchTime modules, taking care that each sprayhead section's 1/4" supply tube and TouchTime module cable are then connected to the same valve (see details in sections 2 and 3).

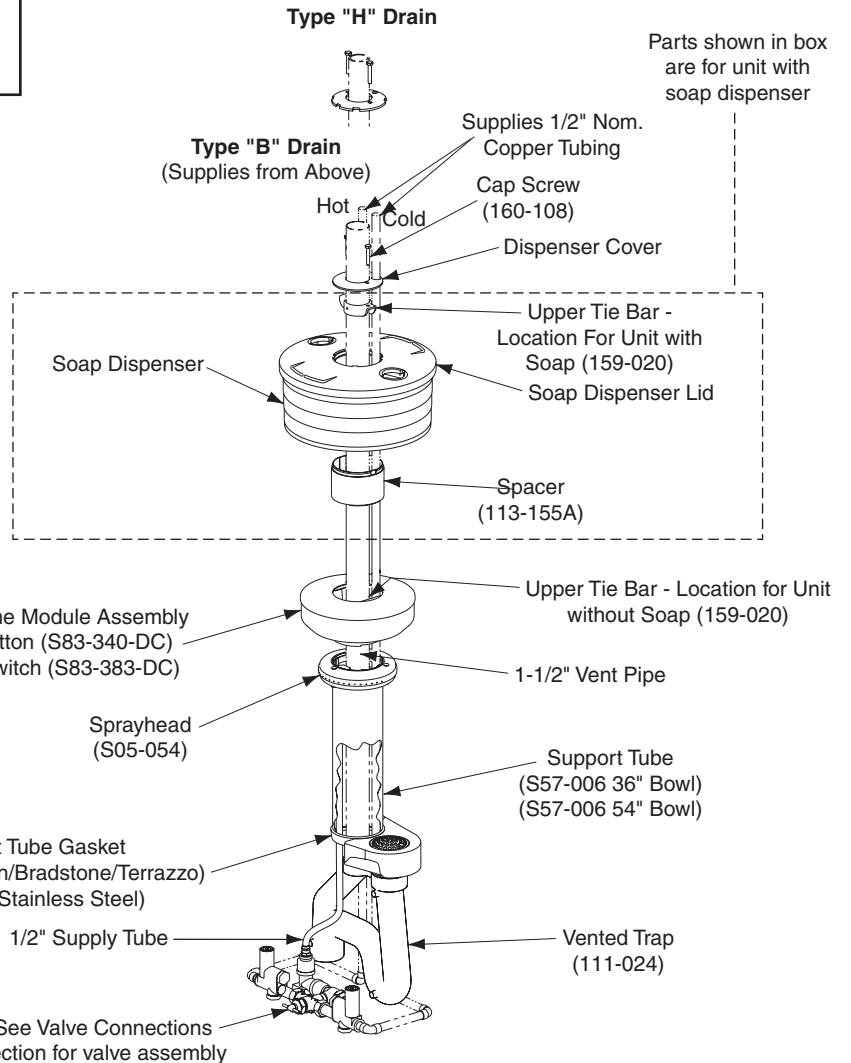
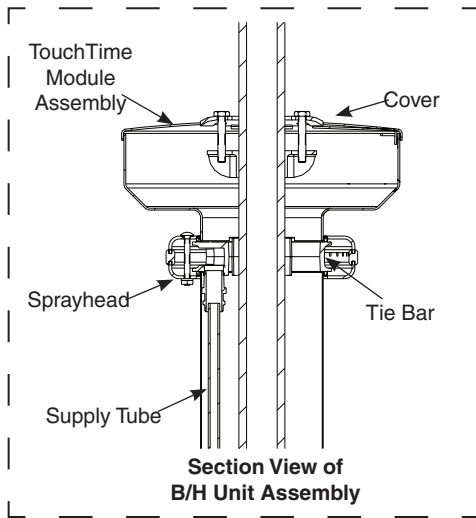

Some optional equipment shown.



TouchTime® Activation Modules - Non-Sectional Circular Washfountains WF2505, WF2508, WF2605, WF2608, WF2705, WF2708, WF2805 & WF2808

P.O. Box 309 • Menomonee Falls, WI 53052-0309 • 1 800 BRADLEY • 262 251 6000 • bradleycorp.com

1b Assemble TouchTime® – B and H Units (H Shown) (cont...)

D Insert the 1-1/2" vent pipe (supplied by installer) through the TouchTime module, sprayhead and support tube. Connect to vented trap provided.



Skip to step F for units without soap.

E For units with soap option, install the spacer, soap dispenser and cover in position on top of air module. Slide tie bar over 1-1/2" vent pipe 1/2" below top of soap dispenser lid and secure with set screws. Slide the dispenser cover over 1-1/2" vent pipe and secure with 2 screws included with tie bar.

F Slide tie bar over 1-1/2" vent pipe 1/2" below top of air module cover and secure with set screws. Slide the dispenser cover 1-1/2" vent pipe and secure with 2 screws included with tie bar.

G Connect vent pipe to vent through ceiling with pipe union.

H **FOR B UNIT:** Install 1/2" nominal copper tubing supply lines (pass them through holes in cover down through support column) and connect to stops using suitable fittings.

Unit with "H" Drain and TouchTime Module Shown, Also Available with "B" Drain

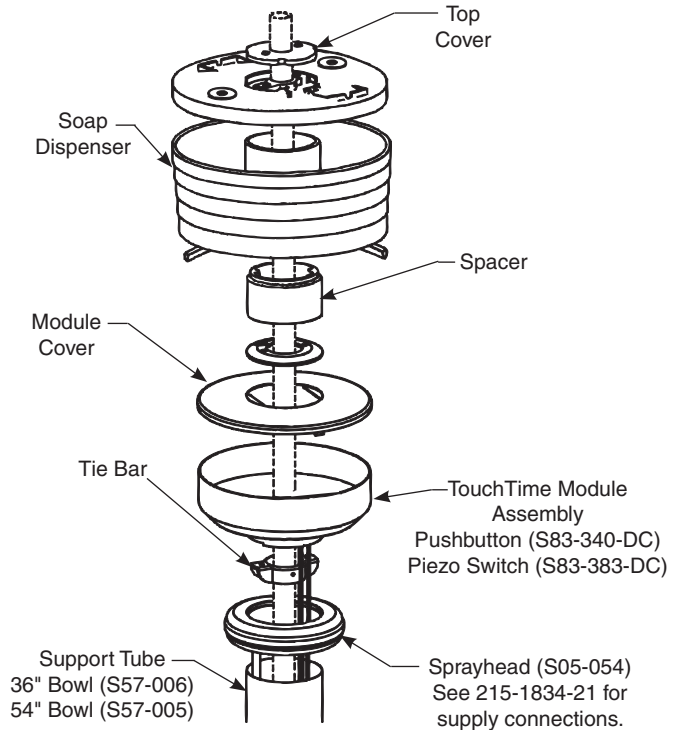

Some optional equipment shown.



2 Connect Valve and Tubing for Non-Sectional TouchTime Control



Flush supply lines before making connections.



Other components not shown for clarity.

A Connect 1/2" dia. tubing from the sprayhead to the solenoid assembly. The male connector for the valve assembly will remain tight and leakproof when tubing is cut and installed properly. Follow the procedures below when installing tubing to ensure that you achieve a leakproof seal.

- Using a sharp razor, cut tubing squarely and remove any burrs. DO NOT pinch or crush end of tubing.
- Loosen nut on fitting. Moisten end of tube and push into fitting until it is firmly seated. Tighten nut to secure tube to fitting (make sure nut is securely tightened).
- If connector leaks, reseal tubing according to above procedure. If leaking persists, replace male connector, or call your Bradley representative for assistance.

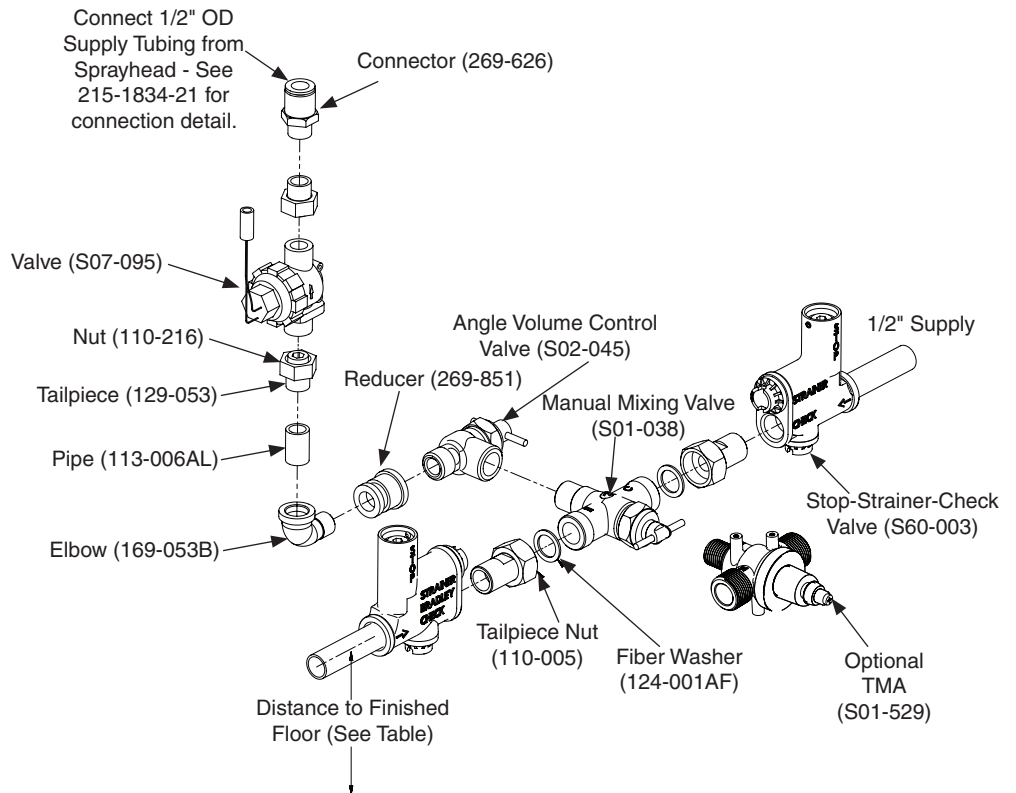

Distance from 1/2" Supply to Finished Floor

| Model | Type A | Type B | Type O | Type H |
|-----------------|----------------|-----------------|----------------|-----------------|
| Standard Height | 9" (229mm) | 6-3/16" (157mm) | 9" (229mm) | 6-3/16" (157mm) |
| Juvenile Height | 5-1/4" (133mm) | 3-7/16" (87mm) | 5-1/4" (133mm) | 3-7/16" (87mm) |

B

Connect the stop-strainer-check valves, mixing valve, volume control valve and solenoid valve assembly to the supplies as shown. Use pipe sealant to seal threads.



TouchTime® Activation Modules - Non-Sectional Circular Washfountains WF2505, WF2508, WF2605, WF2608, WF2705, WF2708, WF2805 & WF2808

P.O. Box 309 • Menomonee Falls, WI 53052-0309 • 1 800 BRADLEY • 262 251 6000 • bradleycorp.com

2 Connect Valve and Tubing for Non-Sectional TouchTime Control (Cont...)



For "A" and "H" units skip step C.



Bowl, tubing and supplies not shown for clarity.

C

For overhead supply, install 1/2" nominal copper supply tubing by passing lines through holes in the dispenser cover and then down through the support tube.

D

Using suitable fittings, install the complete valving assembly to the supplies as shown at the approximate height indicated in table on previous page.

E

Connect the 1/2" supply tubing from the sprayhead to the solenoid valve assembly.

F

When tubing and wiring connections (see electrical connections section) are complete, angle volume control valve is to be used as volume control to control spray pattern from sprayhead. Also verify that each pushbutton activates sprayhead.

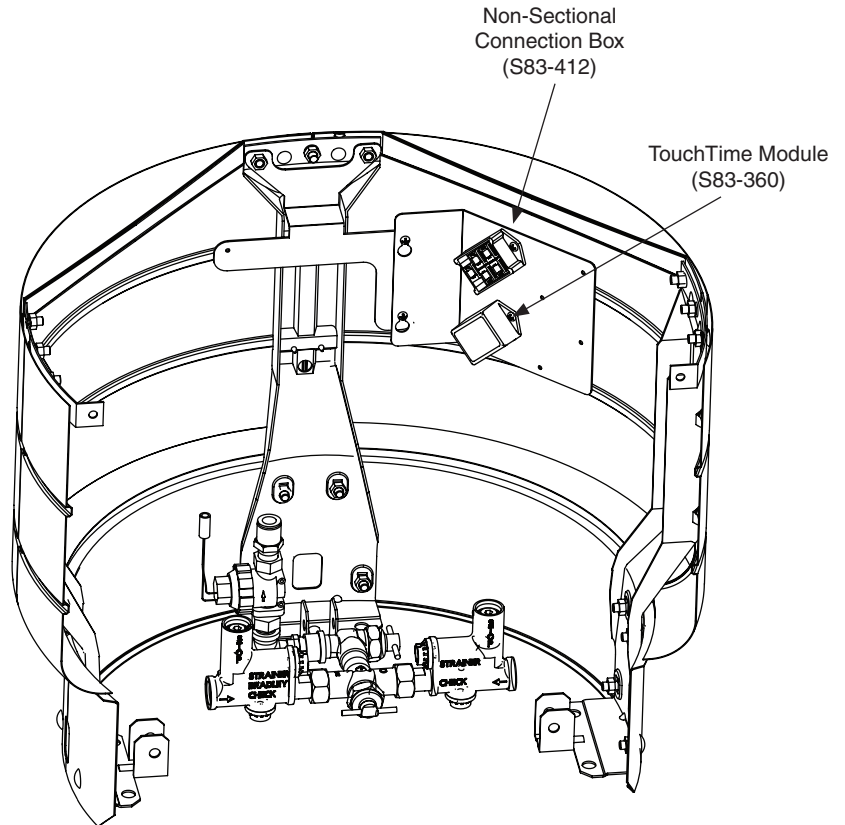

Manual mixing valve shown.



TouchTime® Activation Modules - Non-Sectional Washfountains WF2505, WF2508, WF2605, WF2608, WF2705, WF2708, WF2805 & WF2808

P.O. Box 309 • Menomonee Falls, WI 53052-0309 • 1 800 BRADLEY • 262 251 6000 • bradleycorp.com

3 Electrical and Supply Connections

⚠ WARNING The TouchTime activation must be connected with a 12V DC plug in adapter. Connections to 110 VAC can cause personal injury and will result in damage to the electronics.

✓ Mechanical pushbutton shown, piezo switch similar.

✓ Activation of the push button takes place only when it is released, thereby preventing “hold open” activation.

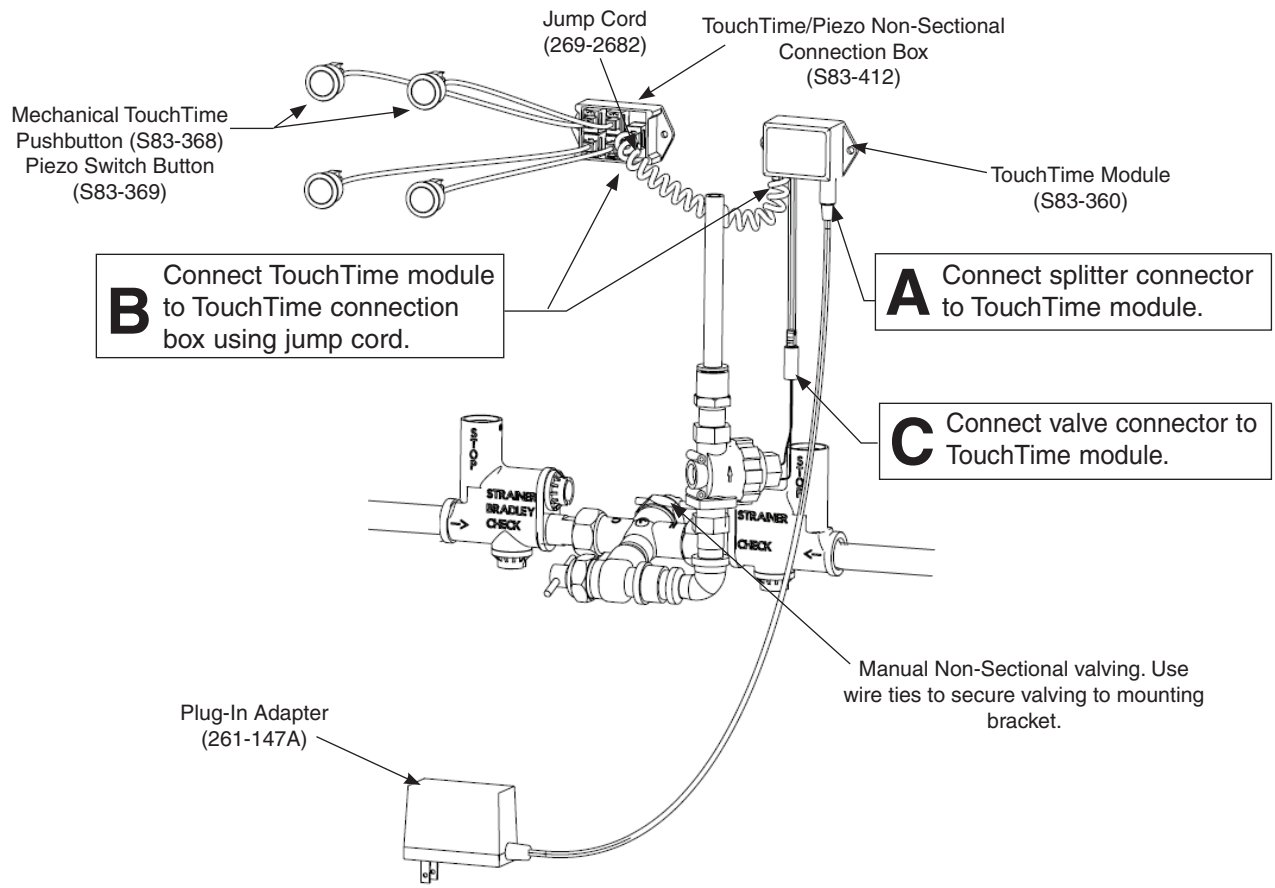



TouchTime® Activation Modules - Non-Sectional Circular Washfountains WF2505, WF2508, WF2605, WF2608, WF2705, WF2708, WF2805 & WF2808

P.O. Box 309 • Menomonee Falls, WI 53052-0309 • 1 800 BRADLEY • 262 251 6000 • bradleycorp.com

4 Adjusting the TouchTime Module

The TouchTime module is set at the factory with the selector switch in position 5. This provides a 11 second time out period.

The 24 hour flush function will activate water flow for a period of 60 seconds any time there has been no activation within the past 24 hours. This function is used to help clear stagnant water from the plumbing system and can provide some measure of prevention against the formation of bacteria in supply pipes.

A To adjust the TouchTime module to a different time out period, turn the selector switch to the desired time out setting (4 through 9 for no flush, A through F for 24 hours flush) as indicated on the module label.

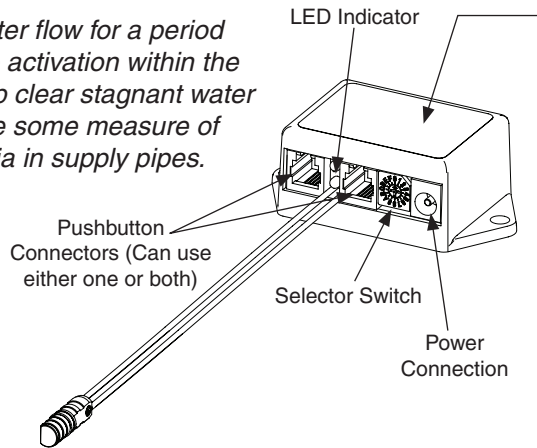

| | |
|----------------------------------|---------------------|
| S83-360 Timer | |
| Indicators | |
| Red = Disabled | |
| Green = In Use/Activation Length | |
| Diagnostic - See Instructions | |
| 0: Test Timer Module I/O | |
| 1: Solenoid Open | |
| Custom - See Instructions | |
| 2: Push Button Light On/Off | |
| 3: Timeout Period | |
| Timeout Setting | |
| 4: 4s, no flush | A: 4s, 24hr flush |
| 5: 11s, no flush | B: 11s, 24hr flush |
| 6: 15s, no flush | C: 15s, 24hr flush |
| 7: 30s, no flush | D: 30s, 24hr flush |
| 8: 60s, no flush | E: 60s, 24hr flush |
| 9: 180s, no flush | F: 180s, 24hr flush |
| 12VDC | |
| 114-325 Rev B | |

5 Turn on Water and Electricity, Test and Adjust Unit

A Turn on power to transformer. The solenoid will buzz when a pushbutton/piezo switch is activated. If no buzz, check wiring.

B Turn on water supply and check for leaks. Activate each pushbutton/piezo switch to purge air from the lines.

Check to make sure stop valves are open before turning on water.

On units ordered with optional TMA, temperatures are NOT factory preset. Upon installation, the temperature of these valves must be checked and adjusted to ensure delivery of a safe water temperature. Water in excess of 110°F (43°C) may cause scalding.

C Gently turn the manual mixing valve handle until desired water temperature is reached.

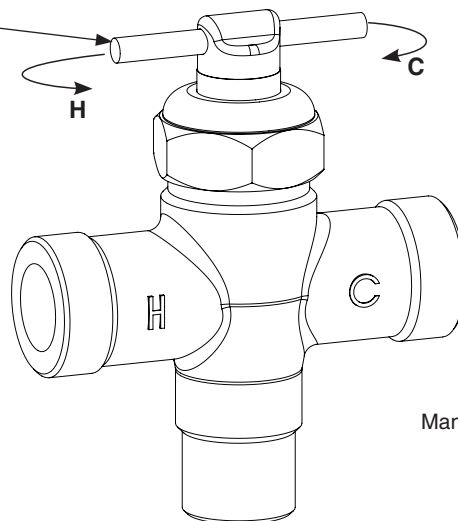

Manual Mixing Valve



TouchTime® Activation Modules - Non-Sectional Circular Washfountains WF2505, WF2508, WF2605, WF2608, WF2705, WF2708, WF2805 & WF2808

P.O. Box 309 • Menomonee Falls, WI 53052-0309 • 1 800 BRADLEY • 262 251 6000 • bradleycorp.com

TouchTime Module Components



Wires not shown for clarity.

| Item | Qty. | Part No. | Description |
|------|------|----------|-------------------------------------|
| 1 | 1 | 219-049 | Shell Assembly - 4 Hole (TouchTime) |
| 2* | 4 | S83-368 | Mechanical Pushbutton |
| 2** | 4 | S83-369 | Piezo Switch |
| 3 | 1 | S04-083 | Module Cover Assembly |
| 4 | 1 | 124-067 | Gasket - Cover |
| 5 | 4 | 110-258 | Nut, M22 x 1 Hex |
| 6 | 1 | 144-066 | Module Sleeve |

*Pushbutton TouchTime Module (S83-340-DC) uses pushbutton S83-368.

** Piezo Switch TouchTime Module (S83-383-DC) uses pushbutton S83-369.

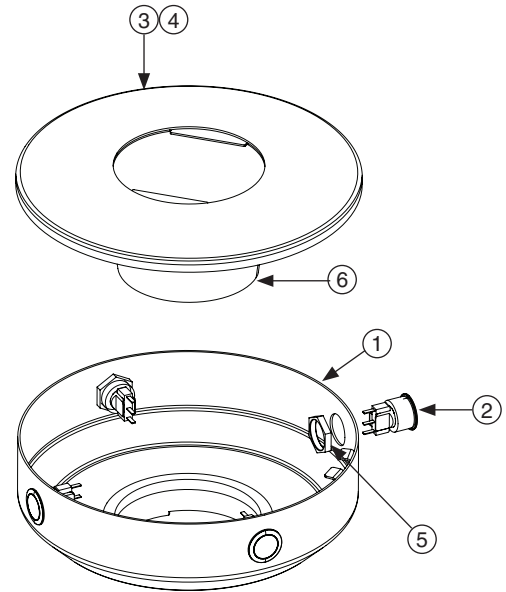

Troubleshooting – Solenoid Valve: Part nos. S07-095



Turn off water supplies to the unit before troubleshooting.

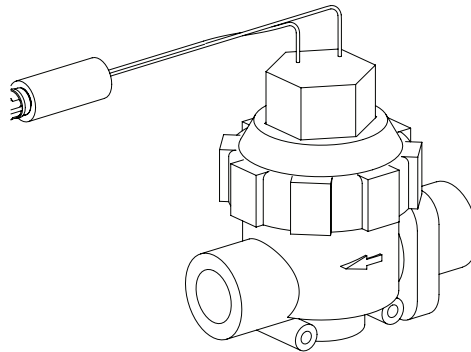

| Problem | Cause | Solution |
|--|--|---|
| An individual operating station fails to shut off and drips. | Internal cartridge failure. | Replace S27-352B cartridge. |
| An individual operating station fails to turn on. | A failed cartridge for the valve or loose electrical connection to the terminal. | <p>Test the station to determine the cause.</p> <ol style="list-style-type: none"> 1. Disconnect the wires from the cartridge of an adjacent valve. Disconnect the wires from the problem valve and reconnect to the adjacent valve. 2. Turn on electrical and water supplies to the unit. Activate the pushbutton/piezo switch on the problem station, and the adjacent station should turn on. <p>If the adjacent station turns on and cycles normally, replace the cartridge on the problem valve.</p> <p>If the adjacent valve fails to turn on, inspect the wires from the pushbutton/piezo switch assembly and do the following:</p> <ul style="list-style-type: none"> • make sure there are no breaks and that the fully insulated disconnect terminals are firmly crimped in place; • turn off the electrical and water supplies; • reconnect to the adjacent valve and turn on the water supplies to the unit; • activate the pushbutton/piezo switch. If the station still fails to turn on, replace the pushbutton/piezo switch assembly. |