

Installation

WF2605

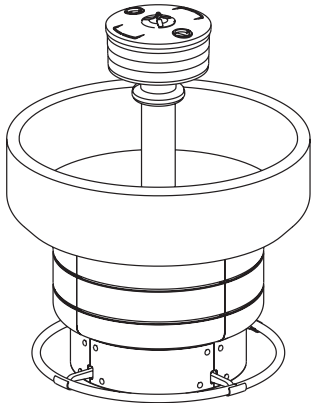

WF3203

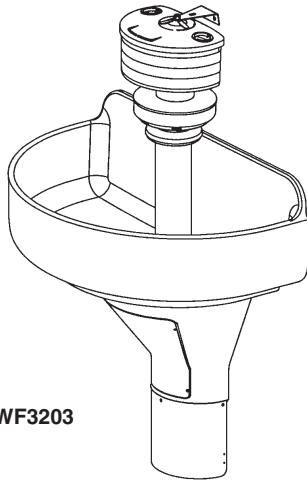

WF2500 Series Terreon Classic
WF2600 Series Terrazzo
WF2700 Series Stainless Steel
WF2800 Series Bradstone
WF3200 Series Terreon Deep Bowl
TDB3100 Series Terreon Deep Bowl



Read the instructions in this manual before beginning installation. Save these instructions and refer to them for inspection, maintenance and troubleshooting information.

For questions regarding the operation, installation or maintenance of this product, visit bradleycorp.com or call 800.BRADLEY (800.272.3539).

Product warranties and parts information may also be found under "Products" on our website at bradleycorp.com.

Separate parts from packaging and make sure all parts are accounted for before discarding any packaging material. If any parts are missing, do not begin installation until you obtain the missing parts.





Safety Information

Installation

Turn OFF electrical supply to the unit before installation.

Compliance and conformity to drain requirements and other local codes and ordinances is the responsibility of the installer.

Proper installation in compliance with industry and government standards for metering faucets requires the following:

1. Adjust volume control until water spray strikes bottom of bowl, 4-inches in from the rim.
2. Air valve metering timing is factory pre-set.

Failure to follow these instructions may negatively affect energy and water use efficiency.

Product/Property Damage

Make sure that all water supply lines have been flushed and then completely turned off before beginning installation. Debris in the supply lines can cause valves to malfunction.



Cleaning and Maintenance for Terreon®

Material Description: Terreon is a densified solid surface material composed of bio based resin and is resistant to chemicals, stains, burns and impact. Surface can be easily repaired with everyday cleansers or fine grit abrasives. Because Terreon is a unique cast material, its aggregate flow and distribution, and shades of color can vary from product to product creating natural characteristics.

Routine Cleaning: For regular cleaning, use mild neutral base cleaners.

Stubborn Stains: Remove tough stains with Soft-Scrub® and a green Scotch-Brite® pad or lightly sand in a circular motion with 240 grit wet/dry sandpaper. The finish can then be renewed with a maroon Scotch-Brite pad.

Scratches: Remove scratches with a green Scotch-Brite pad. The finish can then be renewed with a maroon Scotch-Brite pad.

Hard Water Deposits: Remove hard water deposits with a mild solution of vinegar and water. Always rinse the unit thoroughly after cleaning.

Restoring the surface: Use Hope's® Perfect Countertop to refresh and protect the Terreon Solid Surface material. Dark Terreon colors may require additional care and maintenance. For complete instructions on this additional maintenance, visit bradleycorp.com.

Repair Kits: Terreon repair kits are available. Contact your Bradley representative or distributor for part numbers and pricing. Repair kits are made to order and have a shelf life of 30 days.

NOTICE! Do not use strong acid or alkaline chemicals and cleaners to clean Terreon. If these chemicals come in contact with the surface, wipe them off immediately and rinse with soapy water. Avoid contact with harsh chemicals such as paint remover, bleach, acetone, etc. Avoid contact with hot pans and objects.

Cleaning and Maintenance for Stainless Steel

Material Description: Stainless steel is extremely durable, and maintenance is simple and inexpensive. Proper care, particularly under corrosive conditions, is essential. Always start with the simplest solution and work your way toward the more complicated.

Routine cleaning: Daily or as often as needed use a solution of warm water and soap, detergent, or ammonia. Apply the cleaning solution per the manufacturer's instructions and always use a soft cloth or sponge to avoid damaging the finish.

Stubborn Stains: To remove stains from stainless steel use a stainless steel cleaner and polish such as Ball® stainless steel cleaner or a soft abrasive. Always follow the manufacturer's instructions and apply in the same direction as the polish lines.

NOTICE! Never use ordinary steel wool or steel brushes on stainless steel. Always use stainless steel wool or stainless steel brushes.

Fingerprints and Smears: To remove fingerprints or smears use a high quality stainless steel cleaner and polish in accordance with the manufacturer's instructions. Many of these products leave a protective coating that helps prevent future smears and fingerprints.

Grease and Oil: To remove grease and oil use a quality commercial detergent or caustic cleaner. Apply in accordance to the manufacturer's instructions and in the direction of the polish lines.

Precautions: Avoid prolonged contact with chlorides (bleaches, salts), bromides (sanitizing agents), thiocyanates (pesticides, photography chemicals, and some foods), and iodides on stainless steel equipment, especially if acid conditions exist.

NOTICE! Do not permit salty solutions to evaporate and dry on stainless steel.

The appearance of rust streaks on stainless steel leads to the belief that the stainless steel is rusting. Look for the actual source of the rust in some iron or steel particles which may be touching, but not actually a part of the stainless steel structure.

NOTICE! Strongly acidic or caustic cleaners may attack the steel causing a reddish film to appear. The use of these cleaners should be avoided.



Cleaning and Maintenance for Terrazzo

Material Description: Terrazzo is a mosaic-looking natural stone and concrete material polished to a high gloss and sealed with clear polyurethane resin for long lasting beauty. Terrazzo is precast and composed of 85% stone and 15% binder with steel reinforcing rods cast into the bowl.

Routine Cleaning: Clean daily or as often as conditions require with any standard detergent, warm water and a soft cloth.

Stubborn Stains: If stains have permeated the surface of the terrazzo, follow instructions for restoring the surface listed below.

Restoring the surface: Use paint stripper to remove the existing polyurethane (it is important to remove all of the old polyurethane to ensure a high quality finish). Then use light grit sand paper to remove any stubborn stains that have permeated the surface. Clean and thoroughly dry the bowl. Then apply 2 to 3 coats of polyurethane to the terrazzo in accordance with the manufacturer's instructions. Allow the polyurethane to dry completely per the manufacturer's recommendations before turning on the water.

NOTICE! If the bowl is not completely dry before applying the polyurethane, the polyurethane will not adhere to the surface.

NOTICE! Make sure the surface is completely covered with polyurethane to prevent water from penetrating the surface and damaging the terrazzo.

Repair Kits: Terrazzo repair kits are available. Contact your Bradley representative or distributor for part numbers and pricing.

NOTICE! Do not place acid or alkaline solutions (floor stripper or drain cleaners) into the terrazzo bowl or use them to clean the bowl. If these solutions come into contact with the terrazzo, rinse the bowl immediately with water and inspect for damage. If damage has occurred, follow the directions for restoring the surface. If bowl begins to haze, it is usually a sign that the terrazzo has come into contact with an acid or alkaline chemical or has been exposed to UV radiation. To repair this condition, follow the instructions for restoring the surface.

Cleaning and Maintenance for Bradstone

Material Description: Bradstone is an extremely durable plastic material made of reinforced thermosetting polyester resins, finely ground inorganic fillers and fade resistant pigments. Bradstone is impervious to most chemicals and stains.

Routine Cleaning: Soap and dirt accumulations should be washed off with detergent cleaners. Abrasive and caustic cleaners are not recommended. An occasional waxing with automotive wax will make future cleaning even easier.

Brand Names

Use of brand names is intended only to indicate a type of cleaner. This does not constitute an endorsement, nor does the omission of any brand name cleaner imply inadequacy. Many products named are regional in distribution, and can be found in local supermarkets, department and hardware stores, or through your cleaning service. It is emphasized that all products should be used in strict accordance with package instructions.



This document describes installation of washfountain bowl and pedestal only. Some optional equipment and accessories are shown for clarity. For activation, optional equipment and accessory installation, see installation documents included with those parts.



Before installation of bowl and pedestal assemblies, review all included instructions. Some options may require additional steps during the bowl and pedestal installation process.

Supplies Required by Installer

- (4) 1/2" lag bolts, screws or other fasteners to anchor washfountain pedestal
- 1/2" nominal copper tubing for hot and cold water supply lines
- 1" hot and cold water or tempered supply lines and fittings (see activation instructions)
- Reducing fittings and 1/2" nominal copper tubing supply lines for types with supplies from above (see activation instructions)
- Standard P-trap
- 1-1/2" drain lines and fittings
- Teflon tape or pipe dope



Semi-Circular Washfountain Dimensions (Optional Equipment Shown)

Model TDB3103

36" Semi-circular - side view

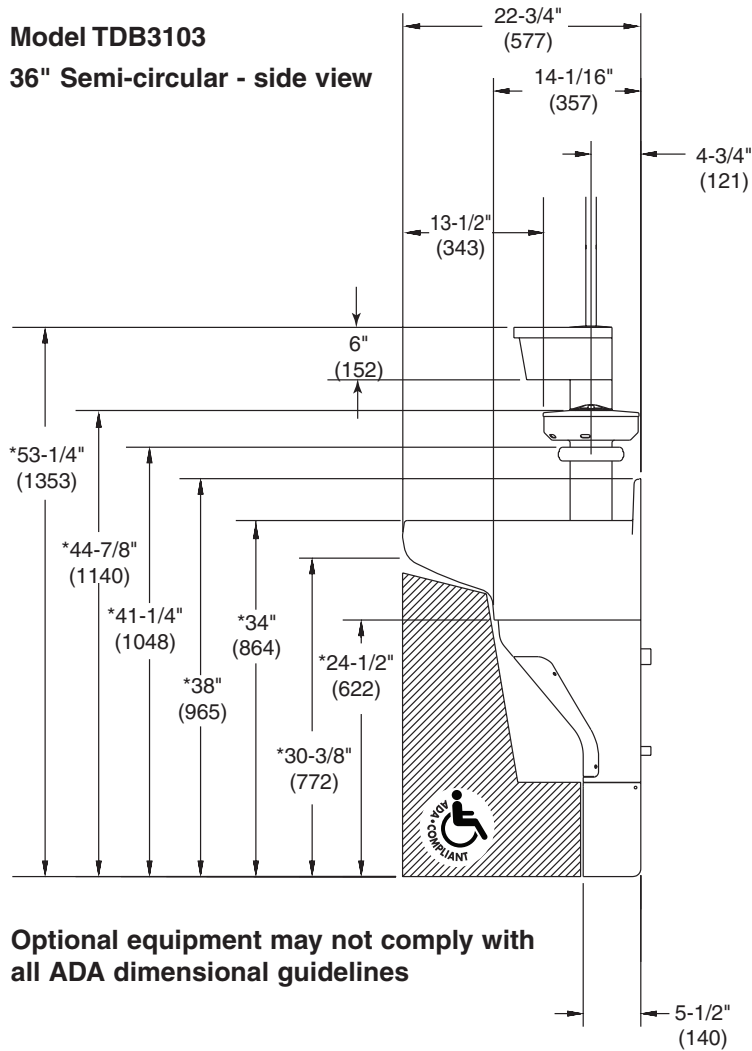

Optional equipment may not comply with all ADA dimensional guidelines

Top View

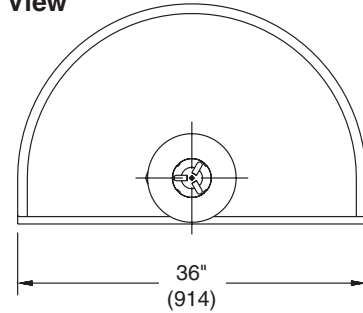

Back View

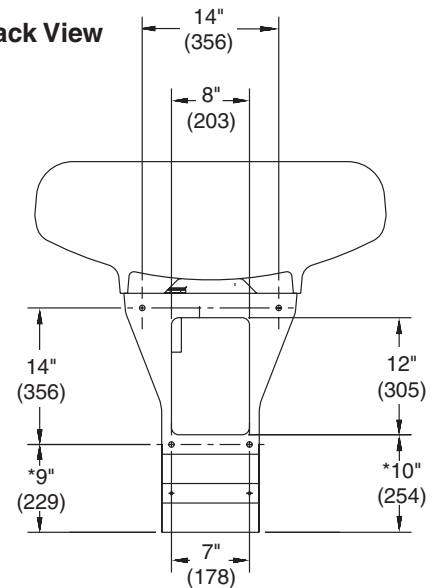

Bottom View

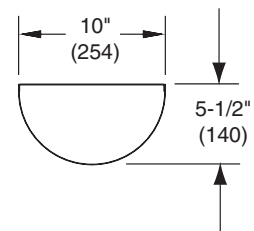

***Adjustments to Vertical Dimensions for Various Rim Heights**

Rim Height	Application	Adjustment
34"	Adult Height ADA, TAS Adult Height	None, as shown
32"	TAS Ages 11 thru 14 or 15, Grades 6 thru 8 or 9	Subtract 2"
30"	TAS Ages 4 thru 10 or 11, Grades 6 thru 8 or 9 & Proposed Juvenile Height ADA	Subtract 4"



Semi-Circular Washfountain Dimensions

Model WF3203

36" Semi-circular - side view

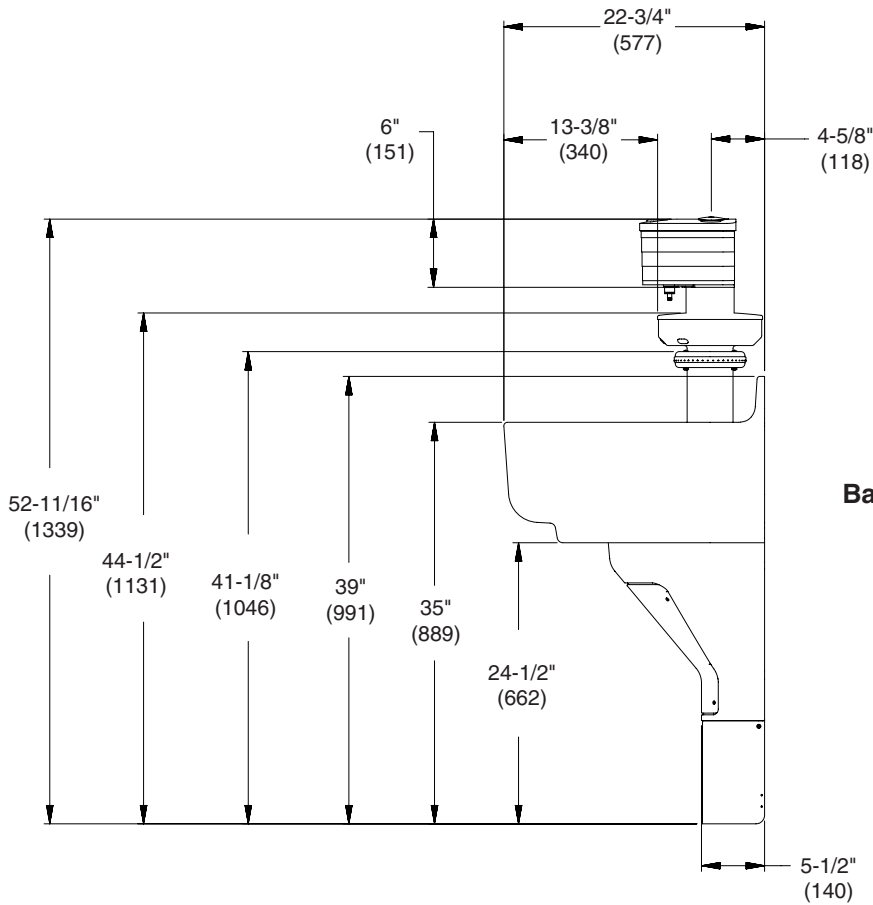

Top View

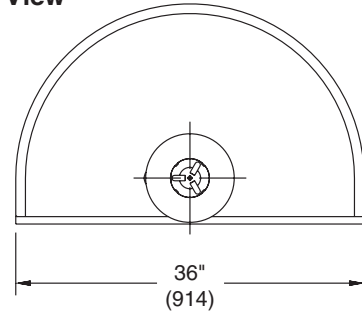

Back View

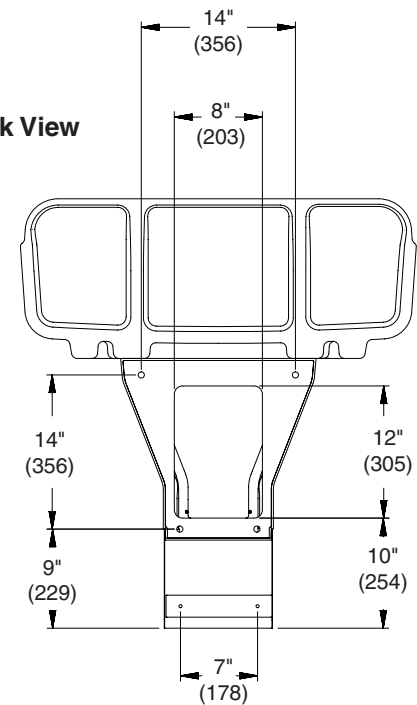

Bottom View

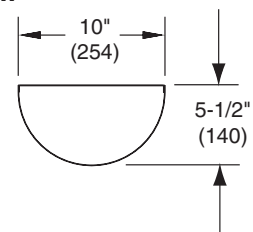



Semi-Circular Washfountain Rough-Ins

(mm)

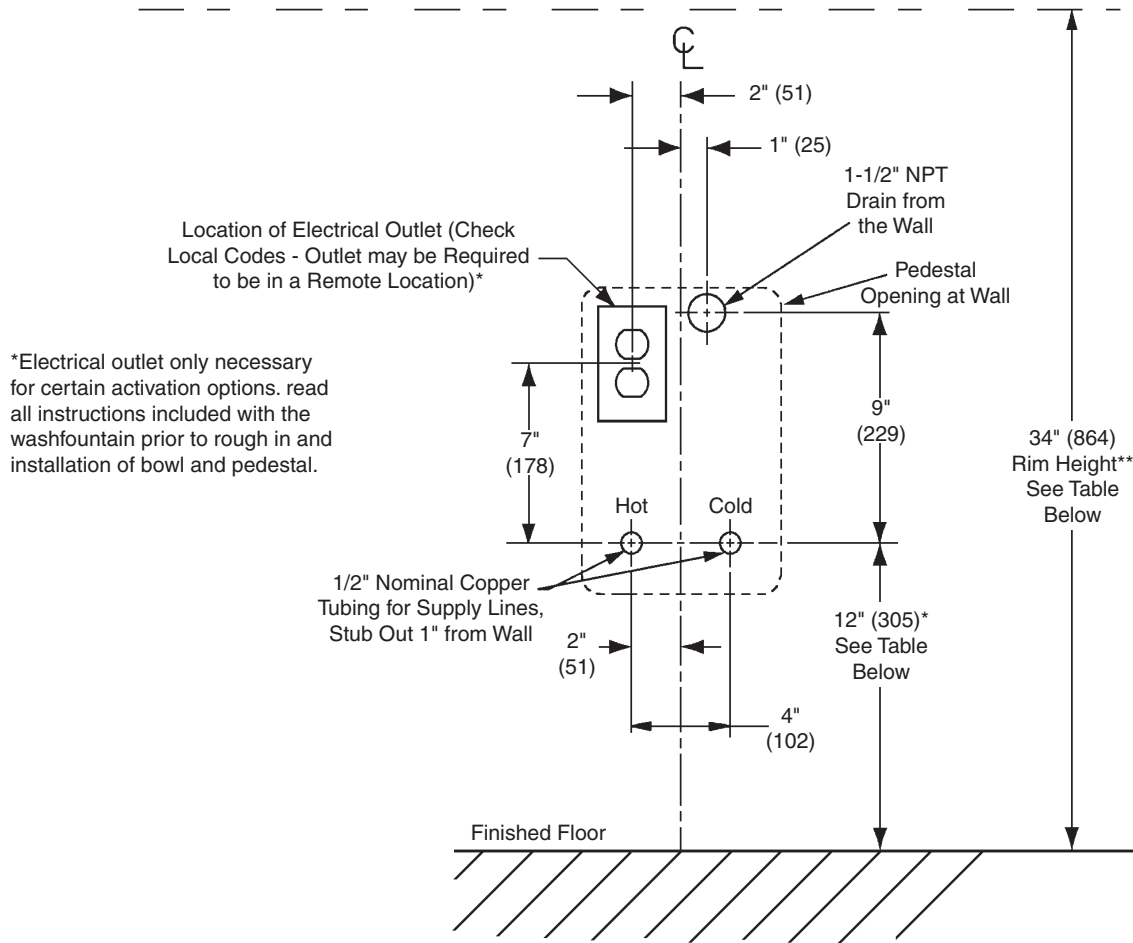

**Adjustments to Vertical Dimensions for Various Rim Heights		
Rim Height	Application	Adjustment
34" 35" (WF3203)	Adult Height ADA, TAS Adult Height	None, as shown
32"	TAS Ages 11 thru 14 or 15, Grades 6 thru 8 or 9	Subtract 2"
30"	TAS Ages 4 thru 10 or 11, Grades Pre-K thru 5 or 6 & Proposed Juvenile Height ADA	Subtract 4"



Rough-In Specifications



Drain P-Trap and supplies by others.

(mm)

Type A Drain

- Supplies through wall
- Vented through wall off-drain

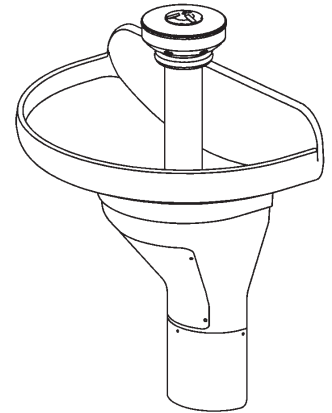
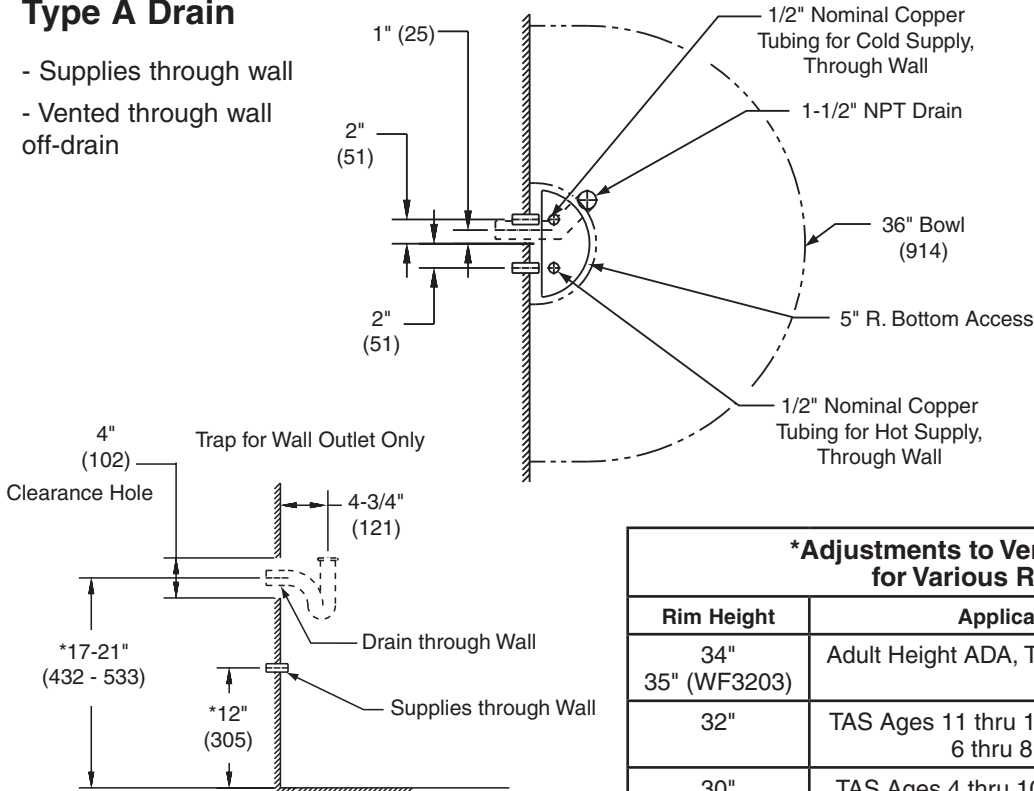

*Adjustments to Vertical Dimensions for Various Rim Heights		
Rim Height	Application	Adjustment
34" 35" (WF3203)	Adult Height ADA, TAS Adult Height	None, as shown
32"	TAS Ages 11 thru 14 or 15, Grades 6 thru 8 or 9	Subtract 2"
30"	TAS Ages 4 thru 10 or 11, Grades Pre-K thru 5 or 6 & Proposed Juvenile Height ADA	Subtract 4"

Type O Drain

- Supplies from above
- Vented through wall off drain

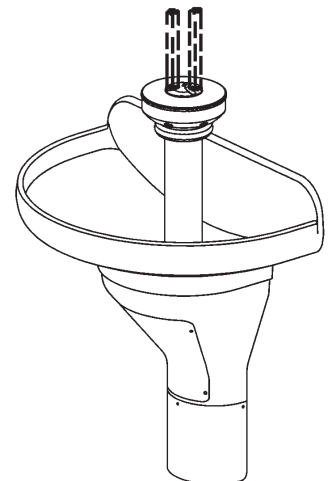
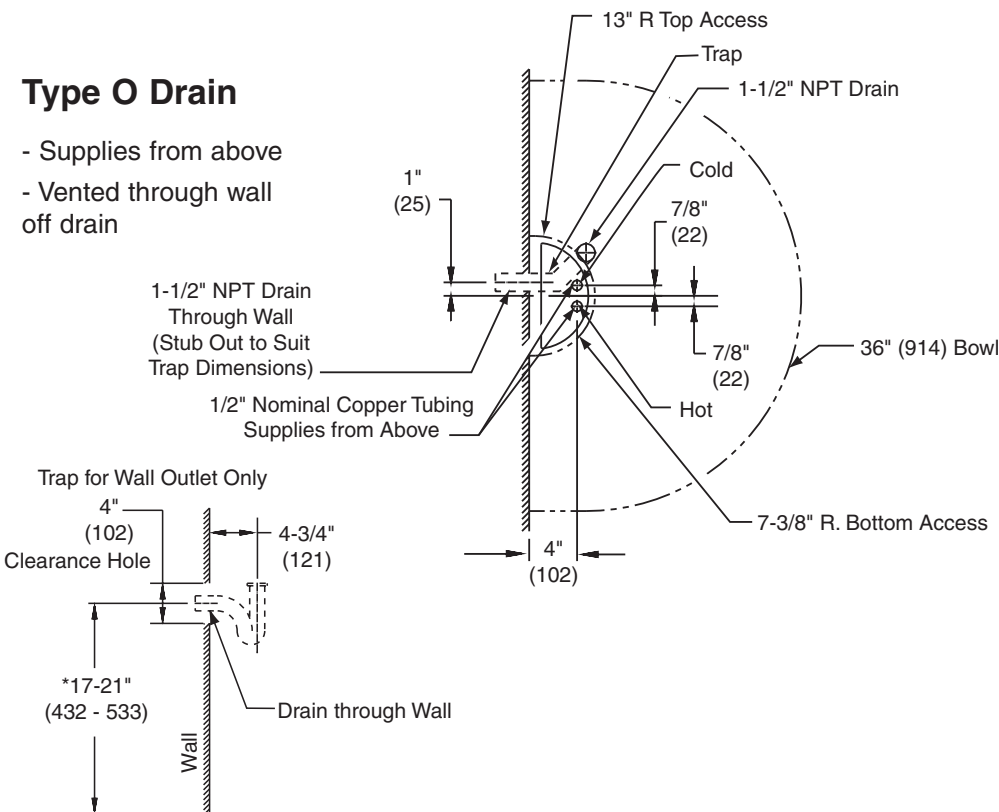



1 Rough-in Drain and Supplies

A Rough in supply and drain piping as required for your installation.



A location to plug in the 24 VAC Transformer is required. Refer to drawing for Outlet Rough-In.

2 Bowl/Pedestal Mounting and Assembly

A Attach the stainless steel pedestal base to the pedestal using supplied screws and finishing washers.



Before attaching 1/4" wing nuts and washer to threaded rod, remove red protective caps from threaded rods. Discard sleeve caps after removal.

B Position the pedestal at the desired location and mark the position of the (4) pedestal wall mounting locations.

CAUTION Bowl surface is very smooth. Approximate weight of bowl is 75 pounds. Handle with Care!

C Secure pedestal to wall with suitable fasteners, 1/2" anchors and 1/2" bolts (supplied by installer).

D Using two people, carefully lift bowl onto pedestal.

E Position the bowl so that the threaded rods in the bowl mate with the slotted holes in the pedestal.

F Using 1/4" wing nuts and washers, secure the bowl to the pedestal, three places.

Top View

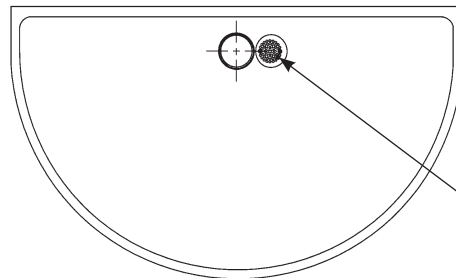

Drain

Front View

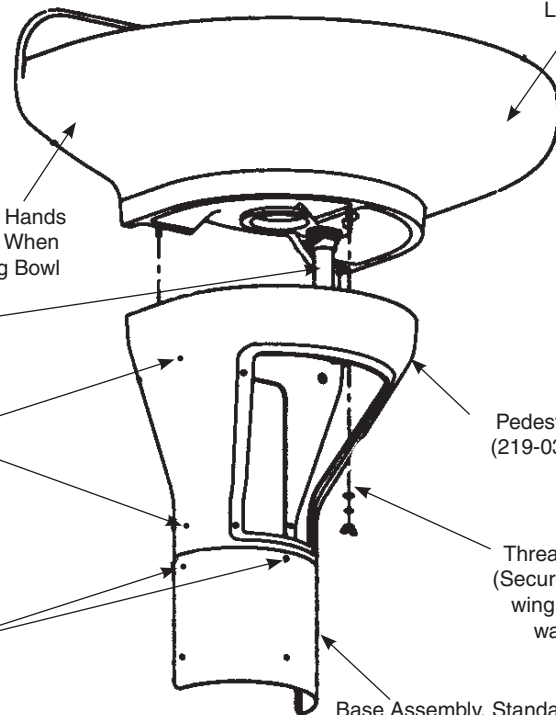

Place Hands Here When Lifting Bowl

Place Hands Here When Lifting Bowl

Drain

Wall Mounting Locations (Typical)

Pedestal (219-039)

Threaded Rod (Secured by 1/4" wing nut and washer)

#10 - 24 Screw (3) (160-248)
Finish Washers (3) (142-002CA)

Base Assembly, Standard Height (S17-281)

Base Assembly, TAS (S17-284)

Base Assembly, Juvenile Height (S17-285)

Shell, Wall Mounted - Trim Piece (186-1306)



3 Installing Drain Spud in Bowl

A Secure drain spud with lock nut and washers.

 Seal between drain spud and drain hole with plumber's putty (supplied by installer).

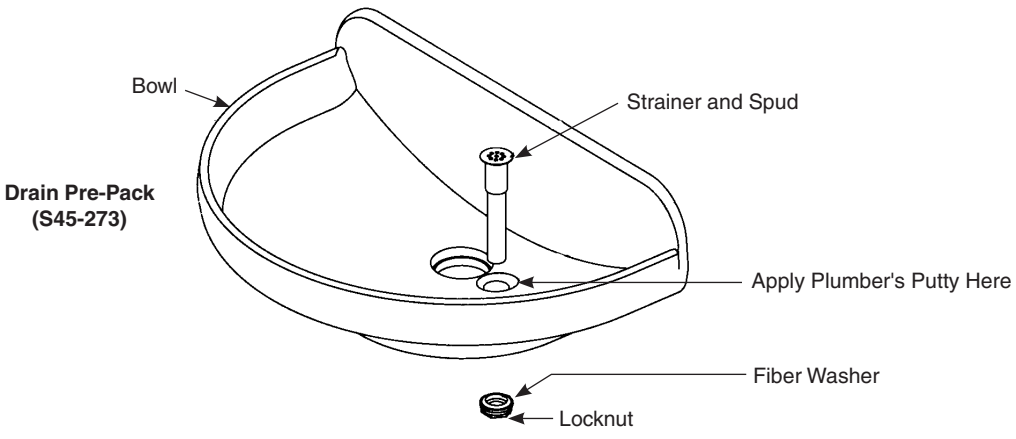



Cleaning and Maintenance for Terreon®

Material Description: Terreon is a densified solid surface material composed of bio based resin and is resistant to chemicals, stains, burns and impact. Surface can be easily repaired with everyday cleansers or fine grit abrasives. Because Terreon is a unique cast material, its aggregate flow and distribution, and shades of color can vary from product to product creating natural characteristics.

Routine Cleaning: For regular cleaning, use mild neutral base cleaners.

Stubborn Stains: Remove tough stains with Soft-Scrub® and a green Scotch-Brite® pad or lightly sand in a circular motion with 240 grit wet/dry sandpaper. The finish can then be renewed with a maroon Scotch-Brite pad.

Scratches: Remove scratches with a green Scotch-Brite pad. The finish can then be renewed with a maroon Scotch-Brite pad.

Hard Water Deposits: Remove hard water deposits with a mild solution of vinegar and water. Always rinse the unit thoroughly after cleaning.

Restoring the surface: Use Hope's® Perfect Countertop to refresh and protect the Terreon Solid Surface material. Dark Terreon colors may require additional care and maintenance. For complete instructions on this additional maintenance, visit bradleycorp.com.

Repair Kits: Terreon repair kits are available. Contact your Bradley representative or distributor for part numbers and pricing. Repair kits are made to order and have a shelf life of 30 days.

NOTICE! Do not use strong acid or alkaline chemicals and cleaners to clean Terreon. If these chemicals come in contact with the surface, wipe them off immediately and rinse with soapy water. Avoid contact with harsh chemicals such as paint remover, bleach, acetone, etc. Avoid contact with hot pans and objects.

Cleaning/Maintenance Instructions for Gel-coated Fiberglass

Material Description: The Terreon Washfountains referenced in this installation manual use a gel-coated fiberglass pedestal.

Routine Cleaning: The gel-coated pedestal should be cleaned daily or as often as needed with a mild solution of detergent and water. Always use a soft cloth to avoid damage to the finish.

Repair Kits: There are no repair kits available for fiberglass materials. However, replacement parts are available, contact your Bradley representative for pricing and part numbers.

NOTICE! Do not expose gel-coated fiberglass to solvents as they will damage the material and may create harmful fumes.

Brand Names: Use of brand names is intended only to indicate a type of cleaner. This does not constitute an endorsement, nor does the omission of any brand name cleaner imply its inadequacy. Many products named are regional in distribution, and can be found in local supermarkets, department and hardware stores, or through your cleaning service. It is emphasized that all products should be used in strict accordance with package instructions.



Non-Sectional Sprayhead



Repair kit does not include sprayhead grommet. Order as a separate item.

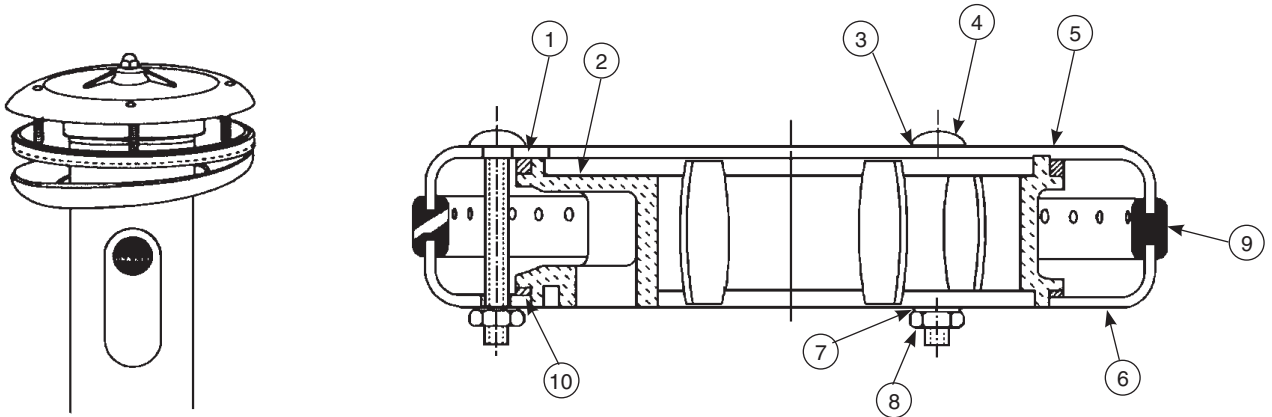

Parts List

Item	Part No.	Description	Sprayhead Assembly	Repair Kit S45-051
			Qty	
1	125-001DE	Neoprene Washer - Top	1	1
2	139-031	Sprayhead Manifold	1	-
3	124-001AL	Washer	3	4
4	160-211	Carriage Bolt	3	4
5	115-061	Sprayhead Top	1	-
6	116-008	Sprayhead Bottom	1	-
7	124-001AT	Washer	3	4
8	161-025	Nut	3	4
9	124-020C	Sprayhead Grommet - Circle	1	-
9	120-020D	Sprayhead Grommet - Semi-Circle	1	-
9	120-020E	Sprayhead Grommet - Corner	1	-
10	125-001DF	Neoprene Washer - Bottom	1	1



Sprayhead Troubleshooting

Problem	Cause	Solution
Water splashes over the rim of the bowl.	Foreign matter has reduced the size of the sprayhead slots, causing greater pressure at the open slots.	Clean the sprayhead: <ol style="list-style-type: none"> 1. Disassemble the sprayhead and dislodge any dirt, lime build-up and foreign debris with a wire brush. 2. Sprayheads with rubber grommet spray rings may be cleaned by rubbing a coin over the grommet.
		Throttle down the volume control (water spray should strike the bowl without splashing outside of the bowl).
Water flow diminishes from the sprayhead.	Strainer portion of the stop-strainer-check valve is plugged.	Remove and clean the strainer screen from the stop-strainer-check valve. <input checked="" type="checkbox"/> <i>The non-sectional sprayhead includes a perforated neoprene spray ring grommet that is self-cleaning. The water pressure flexes the spray holes which slows accumulation of foreign matter and tends to "break loose" any such deposits that may have accumulated.</i>

Sprayhead Tubing Connections

⚠ WARNING Flush supply lines before making connections.

A Using a sharp razor, cut tubing squarely and remove any burrs. DO NOT pinch or crush end of tubing.

B Loosen nut on fitting. Moisten end of tube and push into fitting until it is firmly seated. Tighten nut to secure tube to fitting (make sure nut is securely tightened).

C If connector leaks, reseal tubing according to above procedure. If leaking persists, replace male connector, or call a Bradley representative for assistance.

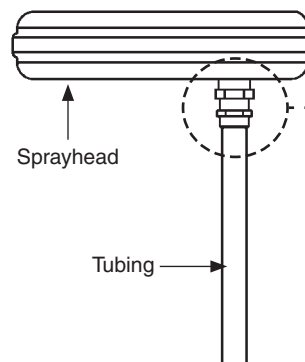
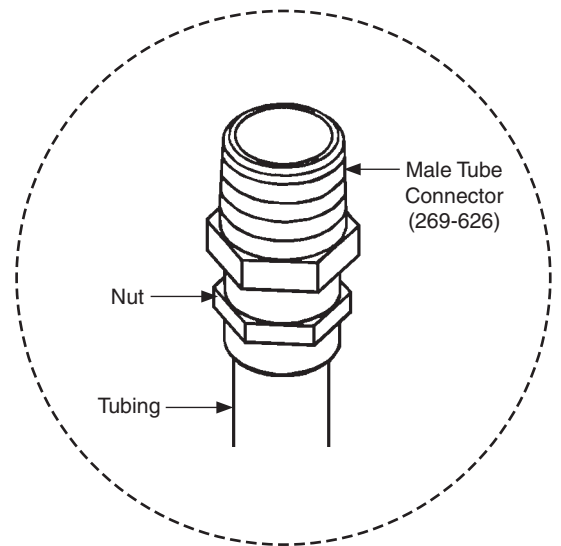



Supplies Required by Installer

- (4) 1/2" lag bolts, screws or other fasteners to anchor washfountain pedestal
- 1/2" nominal copper tubing for hot and cold water supply lines
- Standard p-trap (vented trap supplied by Bradley when required)
- 2" drain lines and fittings
- 1-1/2" vent or tie pipe on fixtures vented through washfountain column
- Teflon tape or pipe dope
- 110 VAC GFI power source for 120VAC/12VDC plug in adapter.
- OPTIONAL: Bradley recommends installing an electrical cutoff switch to the unit. This feature allows no accidental water delivery during regular maintenance and service.

Pre-Installation Information

Adaptive Infrared

The sprayhead is controlled by a solenoid valve, allowing the user to activate a flow of water. The infrared sensor will take a few minutes to adapt to its environment when the unit is powered up.

Solenoid Valve

An electronically controlled solenoid valve serves as the metering mechanism. Few moving parts provide reliable metering performance and the solenoid is unaffected by chemicals and minerals often present in municipal water supplies.



Not all equipment shown in this document is available on all washfountains shown within these pages. See Tech Data for optional equipment available for your washfountain.



Infrared Activation Modules - Non-Sectional Semi-Circular Washfountains TDB3103, TDB3104, WF3203, WF3204

P.O. Box 309 • Menomonee Falls, WI 53052-0309 • 1 800 BRADLEY • 262 251 6000 • bradleycorp.com

1a Adaptive Infrared Assembly – A and O Drain Units without Tie Pipe Option

A Install hemmed end (not sharp end) of support tube with gasket onto bowl.

B Place sprayhead with 3/8" tubing onto support tube. Run the tubing down through the support tube to valve tube connector. Make sure the spray holes point away from the wall.

C Place the upper tie bar (notched at both corners of each end) on top of sprayhead. Connect the longer tie rod to the 4-1/4" tie rod using the coupling nut with hex head set screws. Run the tie rod assembly down through upper tie bar and secure from underneath the bowl using lower tie bar (no notches) and hex nut with socket head set screw.

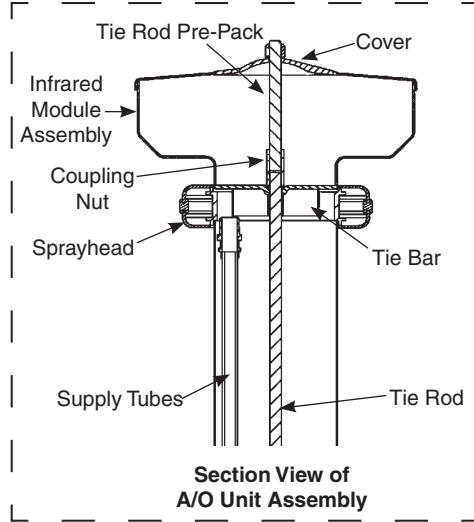

Some optional equipment shown.

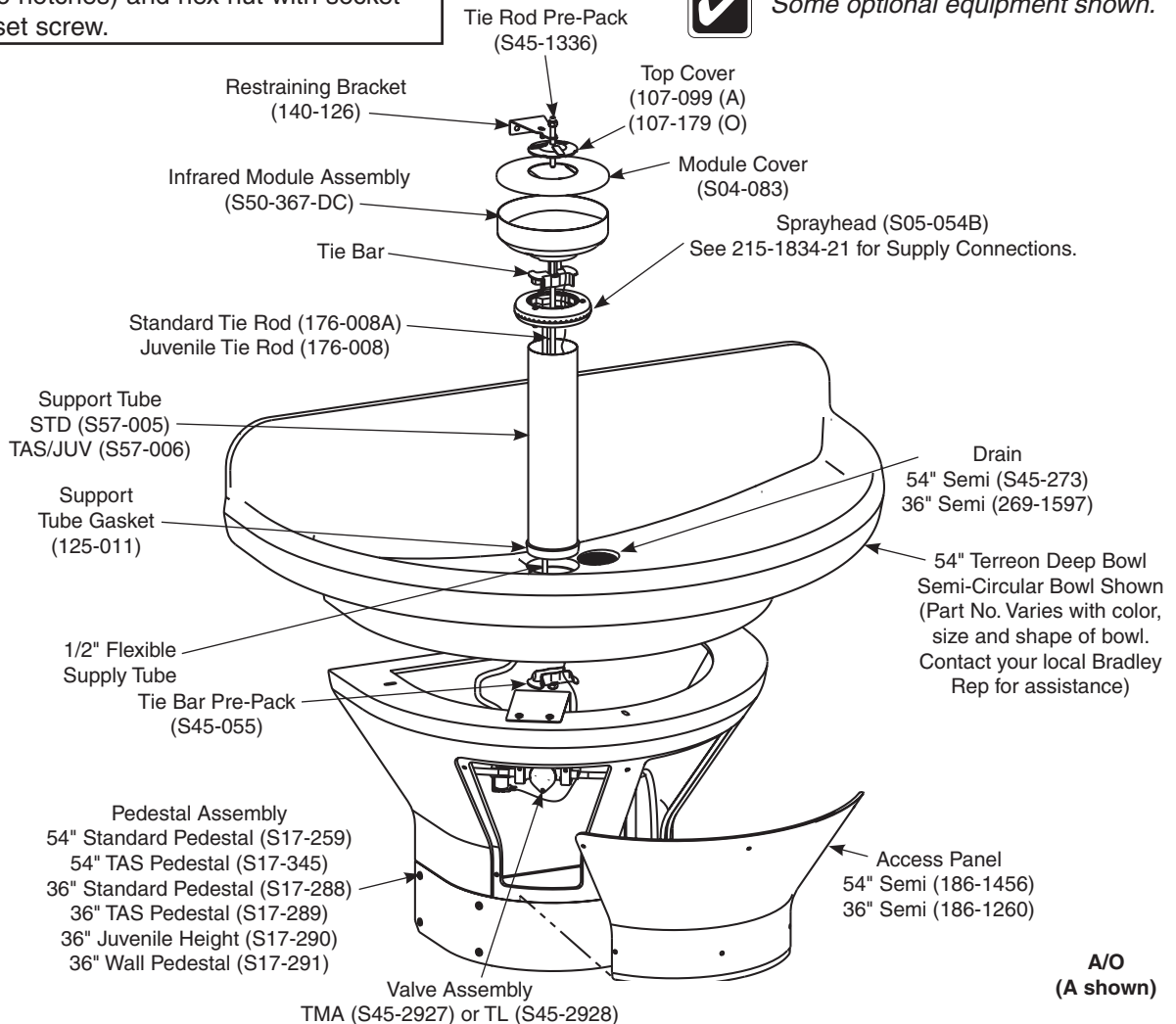

A/O
(A shown)



1a Adaptive Infrared Assembly – A and O Units without Tie Pipe Option

D Place the infrared module assembly on top of sprayhead. Rotate until infrared module locks in with tie bar. Drop 1/8" diameter tube down to valve assembly and connect to the infrared module assembly. Make sure sensors are facing away from the wall.

Skip to step F for units without soap.

E For units with soap option, install the spacer, soap dispenser and cover using the third tie rod (8-5/8" long) and second coupling nut as shown. Secure with acorn nut and set screw.

F Secure module cover and top cover with sprayhead restraining bracket, acorn nut and set screw.

G Connect supply stops onto stub-outs.
Connect flexible hoses to supply stops.

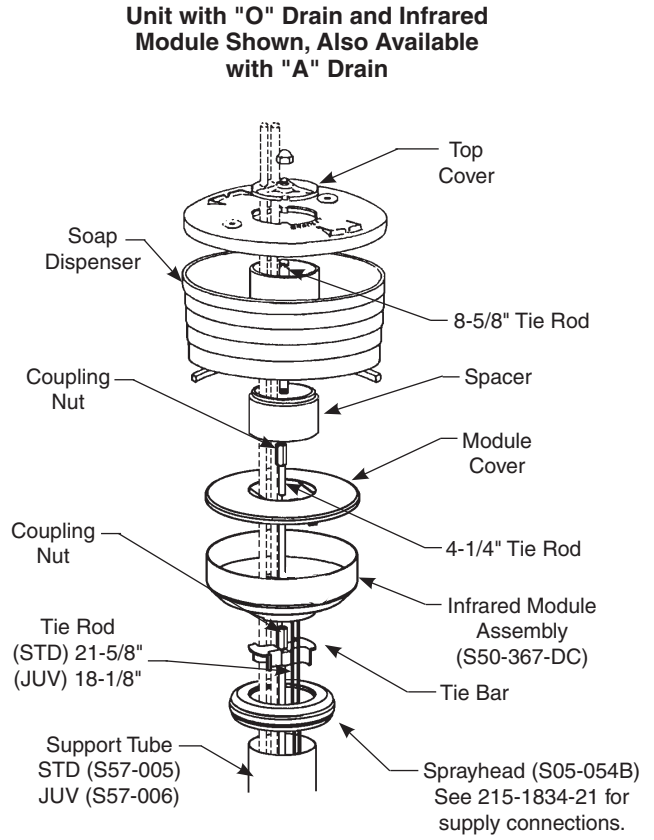

Some optional equipment shown.



Infrared Activation Modules - Non-Sectional Semi-Circular Washfountains TDB3103, TDB3104, WF3203, WF3204

P.O. Box 309 • Menomonee Falls, WI 53052-0309 • 1 800 BRADLEY • 262 251 6000 • bradleycorp.com

1b Adaptive Infrared Assembly – B and H Units with Tie Pipe Option

A Install hemmed end (not sharp end) of support tube with gasket onto bowl.

B Place sprayhead with 3/8" tubing onto support tube. Run the tubing down through the support tube and connect to valve tube connector. Make sure the spray holes point away from the wall.

C Insert the 1-1/2" vent pipe (supplied by installer) down through the support tube and thread into vented trap.

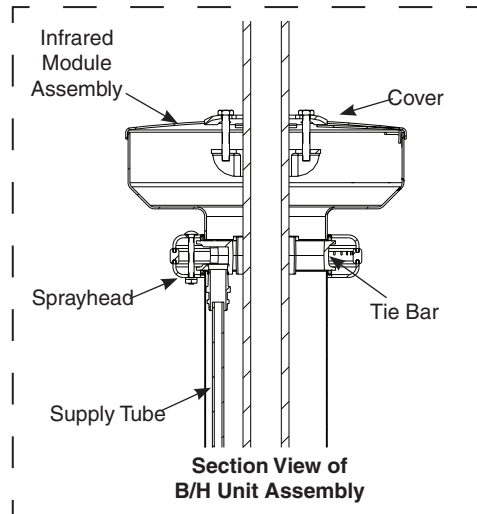

Some optional equipment shown.

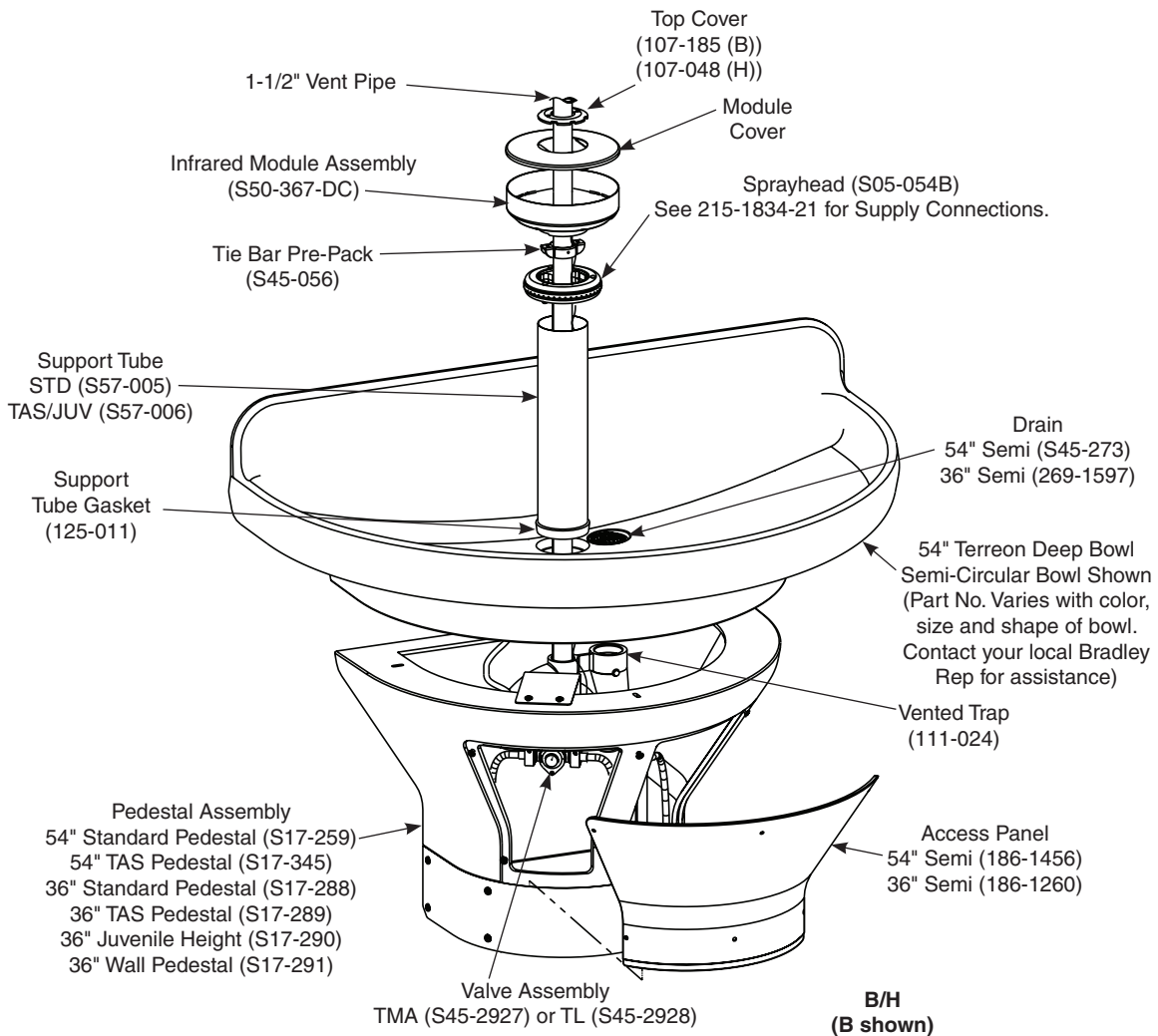



1b Adaptive Infrared Assembly – B and H Units with Tie Pipe Option

D Place the infrared module assembly on top of sprayhead. Rotate until infrared module locks in with tie bar. Drop 1/8" diameter tube down to valve assembly and connect to the infrared module assembly. Make sure sensors are facing away from the wall.



Skip to step F for units without soap.

E For units with soap option, slide the spacer and soap dispenser over the 1-1/2" pipe.

F Position the upper tie bar slightly below the module or soap dispenser and fasten securely to vent pipe with set screws provided. Secure top cover to tie bar with two cap screws provided.

G Connect supply stops onto stub-outs.
Connect flexible hoses to supply stops.

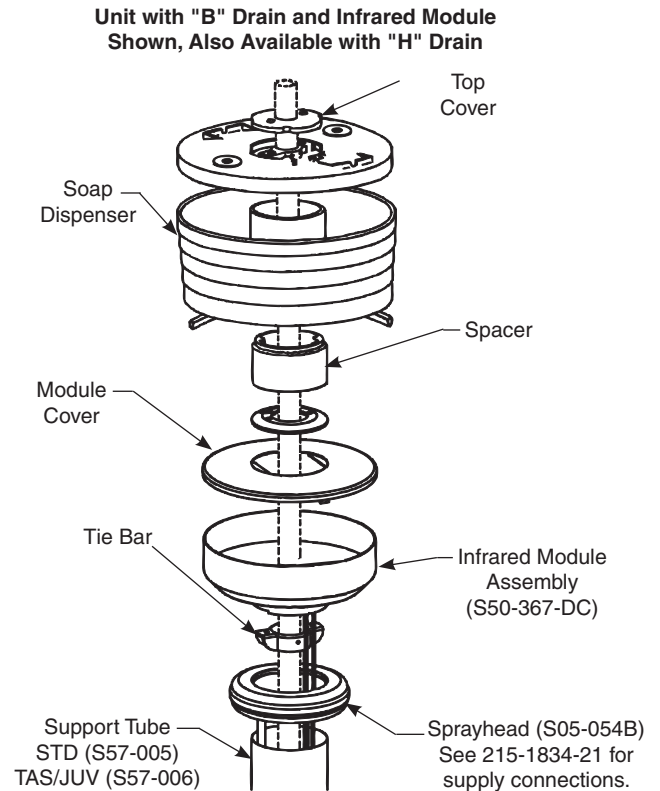

Some optional equipment shown.



2 Connect Valve and Tubing for Non-Sectional Infrared Control



Flush supply lines before making connections.

A

Connect 1/2" diameter tubing to solenoid assembly. Connect tube to sprayhead (see 215-1834-21 for connection detail). The connector for the valve assembly will remain tight and leakproof when tubing is cut and installed properly.

B

Using a sharp razor, cut tubing squarely and remove any burrs. Do not pinch or crush end of tubing.

C

Moisten end of tube and push into fitting until it is firmly seated. If connector leaks, reseal tubing according to above procedure. If leaking persists call your Bradley representative for assistance.



Other components not shown for clarity.

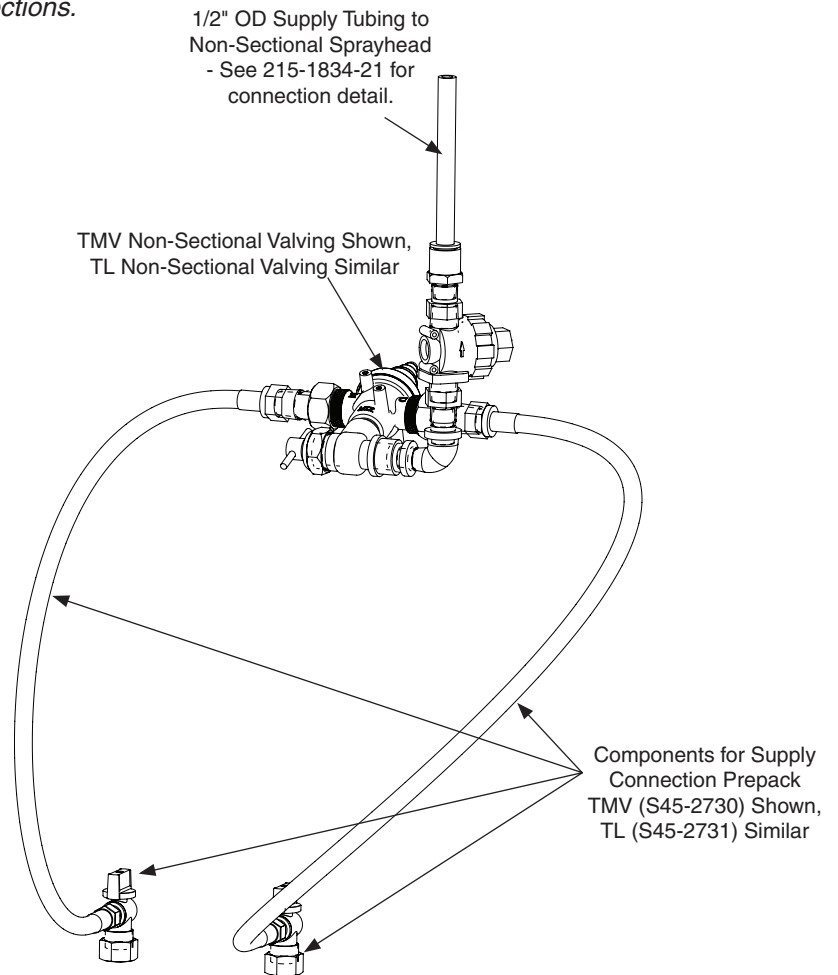



Infrared Activation Modules - Non-Sectional Semi-Circular Washfountains TDB3103, TDB3104, WF3203, WF3204

P.O. Box 309 • Menomonee Falls, WI 53052-0309 • 1 800 BRADLEY • 262 251 6000 • bradleycorp.com

2 Connect Valve and Tubing for Non-Sectional Infrared Control (Cont...)

D Hang valve assembly on pedestal bracket. Use wire ties to secure valve to bracket.

E Attach flexible hosing to thermostatic mixing valve (two places for TMV, 1 place for TL).

Bowl, tubing, wiring and supplies not shown for clarity.

F Connect hoses to the stop valves. Make sure the hot supply is connected to the hot inlet on the valve (marked with the letter "H") and the cold supply is connected to the cold inlet on the valve (marked with the letter "C"). "H" and "C" not applicable for TL valving.

G When tubing and wiring connections (see electrical connections section) are complete, volume control valve is to be used to control spray pattern from sprayhead.

54" TDB Semi-Circular Valve Installation

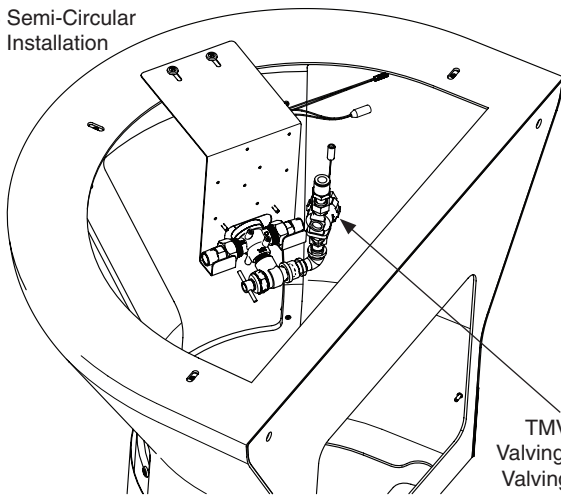

36" TDB Semi-Circular Valve Installation

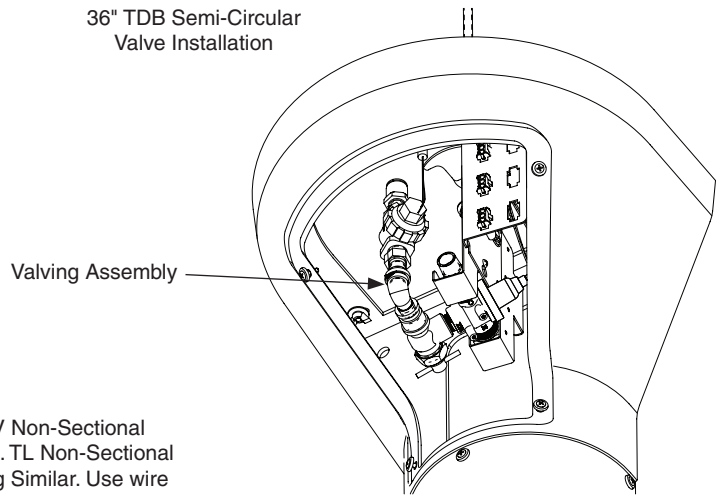

3 Station Harness (S83-367D)
Harness Bracket (140-1222)

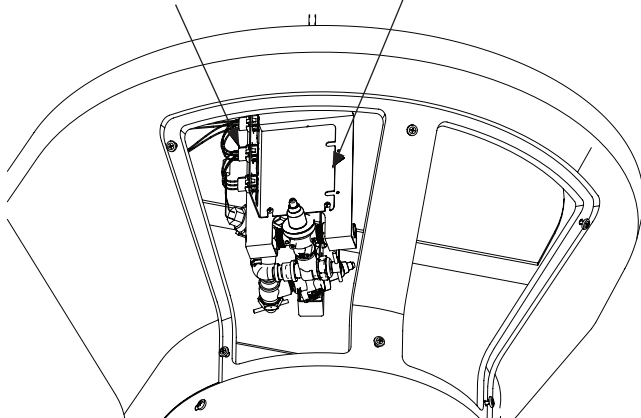

Valve Side View
Tie Rod and Tie Bar (Ref)

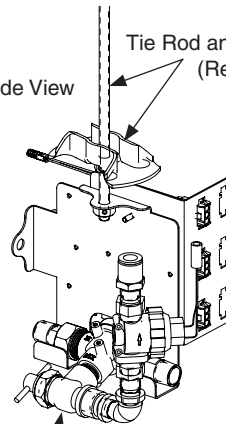

TMV Non-Sectional Valving. Use wire ties to secure valving to mounting bracket.

Module Side View
Tie Rod and Tie Bar (Ref)

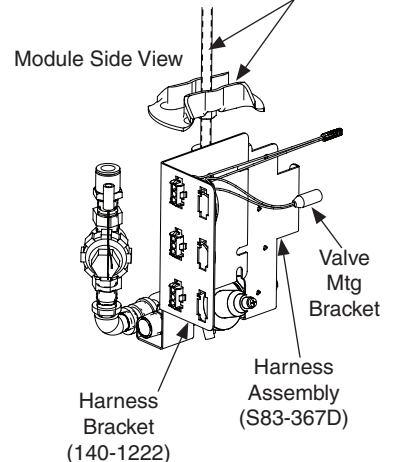



Infrared Activation Modules - Non-Sectional Semi-Circular Washfountains TDB3103, TDB3104, WF3203, WF3204

P.O. Box 309 • Menomonee Falls, WI 53052-0309 • 1 800 BRADLEY • 262 251 6000 • bradleycorp.com

3 Make Electrical Connections

⚠ WARNING! The Adaptive Infrared activation must be connected with a 12V DC plug in adaptor. Connections to 110 VAC can cause personal injury and will result in damage to the electronics.



STOP!!! If installing optional Shroud/Slip Ring or Towel Dispensers, complete those installations before proceeding to Step 4 (see *Optional Equipment Installation* page).

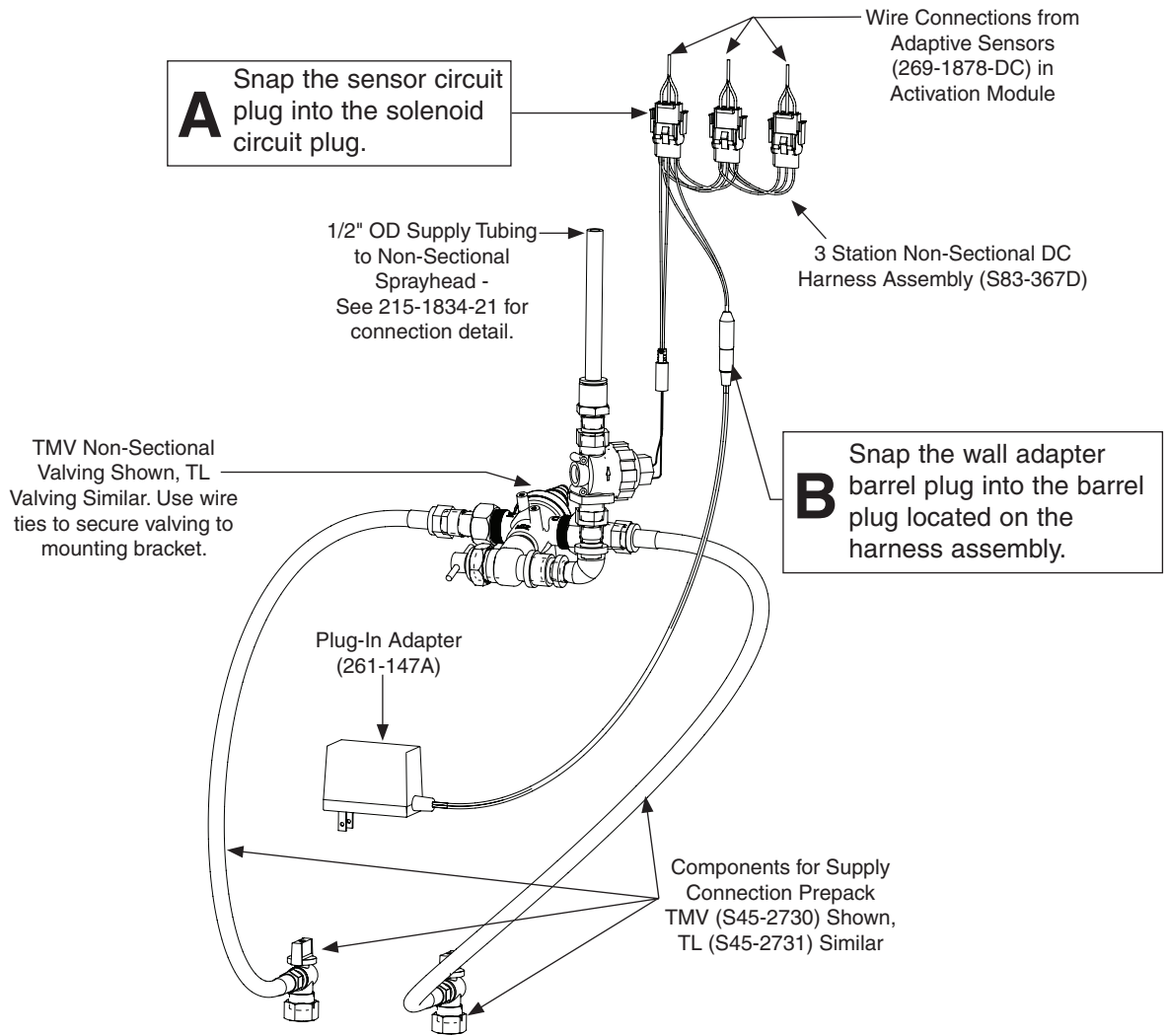



4 Turn on Water and Electricity, Test and Adjust Unit

A Turn on power to transformer. The solenoids will buzz when a sensor is activated. If no buzz, check wiring.

B Turn on water supply and check for leaks. Activate each infrared sensor to purge air from the lines.

Check to make sure stop valves are open before turning on water.

C Loosen the cap screw about 1/4" (4-6 turns) and lift up the cover (do not remove).

Using the cover, turn the cartridge gently until desired water temperature is reached.
D Do not turn past stops as this may damage the unit. Push the cover down and tighten the screw.

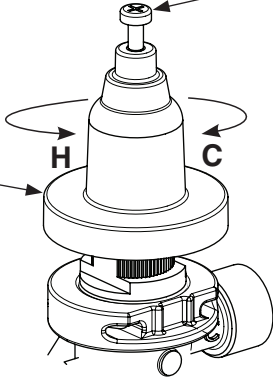

This valve is NOT factory preset. Upon installation, the temperature of this valve must be checked and adjusted to ensure delivery of a safe water temperature. Water in excess of 110°F (43°C) may cause scalding.



Infrared Activation Modules - Non-Sectional Semi-Circular Washfountains TDB3103, TDB3104, WF3203, WF3204

P.O. Box 309 • Menomonee Falls, WI 53052-0309 • 1 800 BRADLEY • 262 251 6000 • bradleycorp.com

Infrared Module Components

Item	Qty.	Part No.	Description
1	1	219-033A	Shell Assembly, Non-Sectional Semi-Circular
2	3	269-1351	Window, Washfountain Sensor
3	1	S04-083	Module Cover Assembly
4	1	124-067	Gasket, Cover
5	3	269-1878-DC	Sensor - Adaptive Infrared
6	1	144-066	Module Sleeve

*S50-367-DC module shown. Other modules similar. Some components and quantities vary my model.

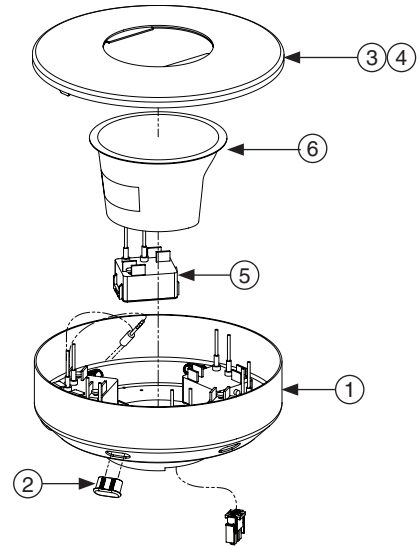

Troubleshooting – Solenoid Valve: Part nos. S07-095



Turn off water supplies to the unit before troubleshooting.

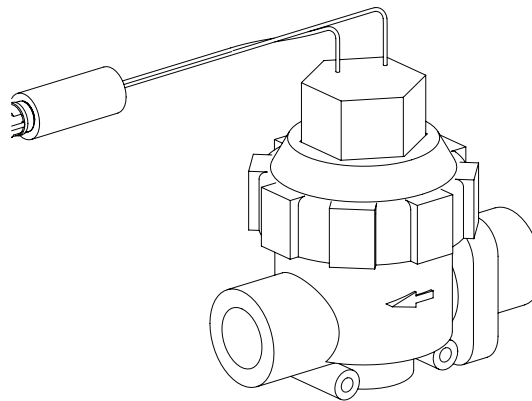

Problem	Cause	Solution
An individual operating station fails to shut off and drips.	Internal cartridge failure.	Replace cartridge S27-352.
An individual operating station fails to turn on.	A failed cartridge for the valve or loose electrical connection to the terminal.	<p>Test the station to determine the cause.</p> <ol style="list-style-type: none"> 1. Disconnect the wires from the cartridge of an adjacent valve. Disconnect the wires from the problem valve and reconnect to the adjacent valve. 2. Turn on electrical and water supplies to the unit. Pass your hand in front of the sensor of the problem station, and the adjacent station should turn on. <p>If the adjacent station turns on and cycles normally, replace the cartridge on the problem valve.</p> <p>If the adjacent valve fails to turn on, inspect the wires from the sensor cable and do the following:</p> <ul style="list-style-type: none"> • make sure there are no breaks and that the fully insulated disconnect terminals are firmly crimped in place; • turn off the electrical and water supplies; • reconnect to the adjacent valve and turn on the water supplies to the unit; • pass your hand in front of the sensor. If the station still fails to turn on, replace the sensor.



Thermostatic Mixing Valve Troubleshooting

Before attempting to troubleshoot the valve or disassemble the components, check for the following conditions:

- If stop valves are used, make sure that they are fully open.
- Make sure that the hot and cold inlet pipes are connected properly, and that there are no cross-connections or leaking stop valves.
- Check the hot water heater output to make sure that it is at least 10° F above the set temperature.



Be sure to close the appropriate shut-off valves prior to disassembly of the valve and reopen the valves after inspection and repair is complete.

Problem	Cause	Solution
External leaks.	Damaged cartridge or O-rings.	Replace cartridge with part number 269-1927
Improper water temperature or temperature fluctuation.	Hot water supply is not 10° above desired set point.	Increase hot water supply temperature
	Valve temperature is not properly set.	Adjust the temperature as shown on page 3 step 2.
Limited water flow.	Dirt and debris have built up in the valve or strainer.	1. Check to make sure both hot and cold supplies are connected to the Navigator mixing valve and that they have water flow. 2. Remove cover and U-clip. Remove the cartridge and clean the strainer. It is not required to grease cartridge, however if desired, use silicone grease only. Do not use grease on check valves.

Parts List

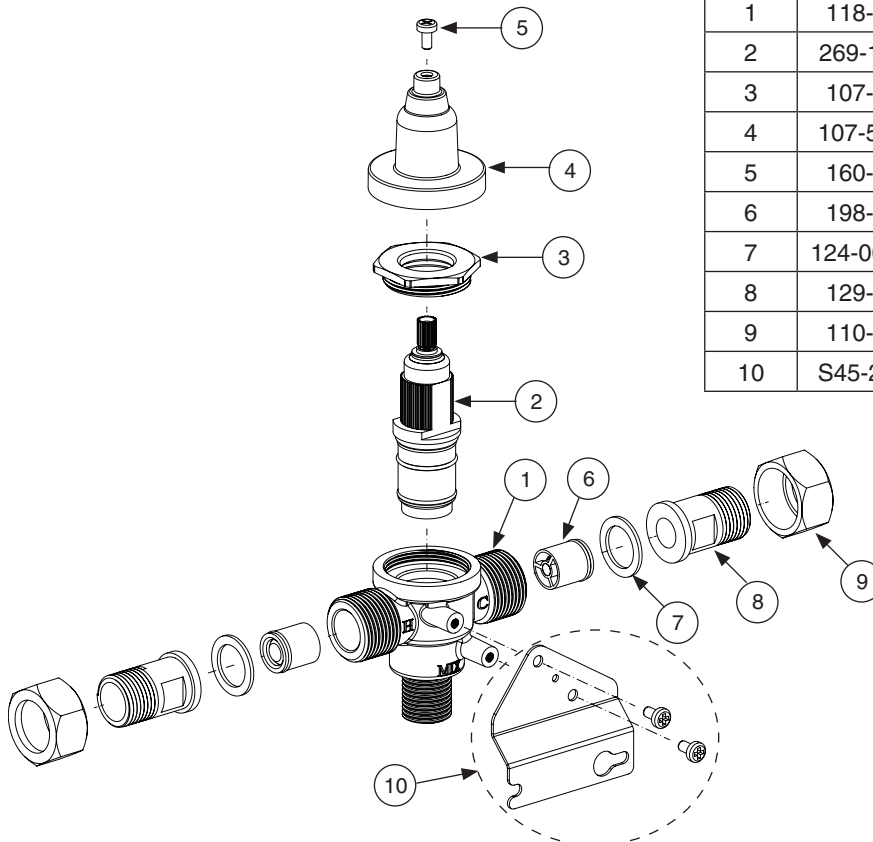

Item	Part No.	Description	Qty
1	118-333	Valve Body	1
2	269-1927	Thermostatic Cartridge	1
3	107-646	Hex Cap	1
4	107-582A	Cover, Lead Free Valve	1
5	160-463	Screw, M4X8 PN	1
6	198-012	Check Valve, 16mm	2
7	124-001AF	Rubber Washer	2
8	129-007	Tailpiece, Unplated	2
9	110-005	Nut, 1-1/16-14 Hex	2
10	S45-2456	Mounting Bracket Kit (Optional)	1