

## Installation and Instruction Manual for 'ApplePie' Wood Burning Stove Range.



### IMPORTANT

**THIS PRODUCT BECOMES VERY HOT DURING USE. TO AVOID SERIOUS INJURY, IT IS RECOMMENDED THAT A SUITABLE FIREGUARD IS USED WHEN YOUNG CHILDREN, THE ELDERLY OR OTHER VULNERABLE PEOPLE ARE PRESENT.**

**ONLY HIGH QUALITY SEASONED LOGS TO BE BURNT ON THIS APPLIANCE. NEVER ATTEMPT TO BURN ALTERNATIVE FUELS OR RUBBISH.**

**Please read instructions carefully prior to installation and keep them in a safe place.**





---

# Contents

<b>Technical Specifications and Declaration of Performance .....</b>	<b>Page 3</b>
<b>Getting Started.....</b>	<b>Page 4</b>
<b>Safety and General Points .....</b>	<b>Page 4</b>
<b>User Instructions .....</b>	<b>Page 5</b>
• Controls for wood-burning.....	Page 5
• Door handle operation .....	Page 5
• How does heat come out? .....	Page 6
• Lighting the fire .....	Page 6
• Tips for successful wood-burning.....	Page 9
<b>Maintenance.....</b>	<b>Page 10</b>
<b>The Clean Air Act.....</b>	<b>Page 11</b>
<b>Installation Instructions .....</b>	<b>Page 12</b>
• Unpacking and moving .....	Page 12
• Pre-install checks.....	Page 12
• Attaching the flue collar.....	Page 14
• Connecting the top oven .....	Page 14
• Connecting to external air supply.....	Page 15
• Connecting side plates.....	Page 16
• Connecting top guard rail.....	Page 16
• Connecting pedestal .....	Page 16
• Securing stove to floor .....	Page 17
• Using enclosure system.....	Page 17
<b>Distances to Combustibles .....</b>	<b>Page 18</b>
<b>Hearth Requirements .....</b>	<b>Page 20</b>
<b>Flue/ Chimney Connection .....</b>	<b>Page 20</b>
<b>Cooking .....</b>	<b>Page 21</b>
<b>Exploded View/ Spare Parts Identification.....</b>	<b>Page 23</b>
<b>Service Records .....</b>	<b>Page 24</b>
<b>Warranty .....</b>	<b>Page 25</b>
<b>General Dimensions.....</b>	<b>Final page/ rear cover</b>

# Technical Specifications + Declaration of Performance

**(For general dimensions please see final page)**

ApplePie by Ekol range, Manufactured by Saltfire Stoves Ltd

Tested in the UK by Kiwa Gastec, Notified Body: 0558

Test standards: EN13240:2001 Amd 2:2004, DIN+, PD6434 (additional particulate emissions test)

Tested to BS, EN (CE), UK Smoke Control (DEFRA), EcoDesign 2022 Tested and Compliant. Tested to EN 13240:2001+Amd 2 (as freestanding stove)	✓
Achievable Heat Output Range	2kW to 4.8kW
Nominal Heat Output	4kW
Total Efficiency	<b>81.6%</b>
Refuel Interval Burning wood	0.75 hour (45 minutes)
CO emission (at 13% O <sub>2</sub> )	0.10%
Mean flue gas temperature	223°C
Mean C <sub>2</sub> H <sub>4</sub> (at 13 % O <sub>2</sub> )	106Nmg/m <sup>3</sup>
Mean NO <sub>x</sub> (at 13 % O <sub>2</sub> )	101 Nmg/m <sup>3</sup>
DIN+ dust (at 13 % O <sub>2</sub> )	24 Nmg/m <sup>3</sup>
Weight Unpackaged	approx 65 to 110kgs depending on configuration
Suggested Clearances to Non-combustible Walls	50mm all round (to suitably thick solid materials)
Minimum Clearances to Combustible Materials:	<ul style="list-style-type: none"> <li>•To rear wall measured from vertical flue adaptor : 50mm when used with Insulated flue 250mm when used with single skin flue pipe</li> <li>• To sides of appliance: 300mm when used with Insulated flue 350mm when used with single skin flue pipe</li> <li>•In corner configuration with insulated flue: 150mm to right side wall 150mm to left side wall</li> </ul> For details of alternative configurations and when using enclosure system, see operating manual
Suitable for positioning on hearth of 12mm thick (relating to UK domestic Building Regulations).	✓
Maximum Hearth Temperature tested under the appliance	35°C
<b>10 Year</b> body warranty for standard domestic use. 12 months body warranty when used commercially or in rented accommodation	✓
Ideal log length	<b>up to 200mm</b>
Air vent in room NOT usually required, (dependent on building air permeability)	✓

Signed:



Cameron Penman, Director, on behalf of Saltfire Stoves Ltd, September 2019



# Getting Started

## Welcome

Thank you for choosing the ApplePie by Ekol.

We are confident that your new stove will provide many years of pleasure and reliable service.

The main purpose of this manual is to guide you in the use and maintenance so that you can get the best out of your home-fire experience.

All stoves will vary and we recommend that even those experienced in the use of wood-stoves read this manual thoroughly in order to fully understand the workings of the Ekol ApplePie.

This manual will also provide installation guidelines however this is not a step by step installation manual as each installation will be dependent upon local and national Building Regulations and safety standards which must be adhered to in addition to any information given here.

The ApplePie stove has been designed specifically for small spaces, and non-conventional structures including tents, yurts, timber cabins, glamping pods, as well as small spaces in domestic fireplaces or freestanding in any room.

It is fully tested for UK and European standards, including CE, BS EN, DEFRA and EcoDesign standards.

## Safety & General Points

NB. Safety is the most important consideration when installing and using your stove. If not installed correctly or used incorrectly a building fire or carbon monoxide poisoning can result.

- 1) All users of this appliance should fully read and ensure they understand the 'User Instructions' section of this manual.
- 2) The appliance must be fitted by a registered installer who is officially deemed competent to undertake the installation, or approved by your local Building Control department.
- 3) All local, national and European Standards and regulations need to be adhered to when installing.
- 4) Only seasoned, dry logs of between 10% and 20% moisture are to be burnt (unless you have purchased the Bioethanol kit). Fuels must never be mixed. Never use as

an incinerator and never burn any liquid fuels other than bioethanol, and only then when the appliance is fully setup for bioethanol burning using the specific Ekol bioethanol adaptation kit.

- 5) All surfaces will become hot during use. Ensure that children, the elderly or other vulnerable people are kept safe by using a suitable fireguard.
- 6) Take note of the minimum distance to combustible items within the 'Distances to Combustibles' section of this manual, and in addition, avoid placing TVs, photographs etc on the wall above the stove or anywhere close by. Never allow combustible items or furnishings to be positioned within 1m from the front of the appliance.
- 7) Do not store any fuel on or near the appliance.
- 8) NOT suitable for use in a shared flue system.
- 9) Your stove will require a constant air supply - Extractor fans and cooker hoods should never be located in the same room as the appliance as this will disturb air supply to the stove potentially causing harmful gases to be emitted into the room.
- 10) Never make unauthorised changes to the appliance.
- 11) Chimney / flue system should be swept at least once a year, and more frequently depending on usage and soot build up, as advised by your qualified chimney sweep.
- 12) This appliance is designed to be used with the door shut, with exception of start up procedure when burning wood, and when burning bioethanol the door should be slightly ajar (see more detailed user instructions).
- 13) Upon first few uses the stove may produce an unpleasant odour due to the paint curing process. Open a window in the room if this occurs.
- 14) Your stove will be heavy and will require between 2 and 4 people to lift. Lifting or trolley equipment may be required dependent upon the body options chosen and the chosen stove location. A 2-wheeled 'sack' trolley is normally ideal.
- 15) Unpacking: Do not drag the stove to its location, instead it should be carefully lifted into place. Do not use sharp blades to cut through packaging material as the stove paint surface and other components may become damaged. Incidental scratches to paint surfaces on the stove from moving or installation can be touched up using suitable high temperature stove paint.

**NEVER USE THE STOVE OR SPACE AROUND THE STOVE TO ATTEMPT TO DRY CLOTHES! - This is a common cause of house fires.**

# User Instructions

## Controls for wood-burning

Figure 1.1

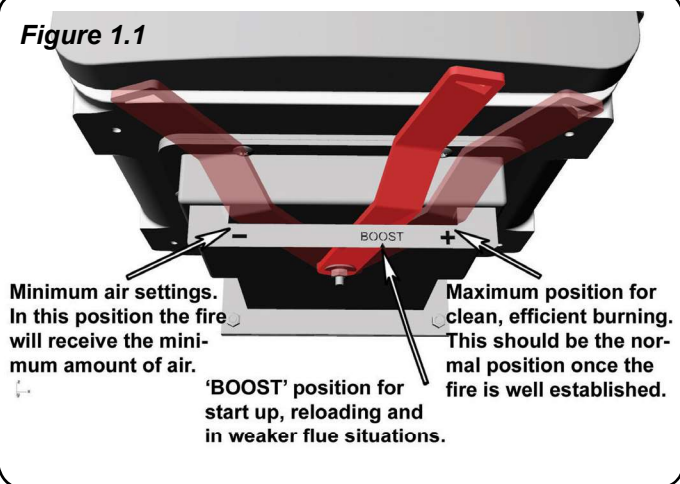

**CAUTION HOT! Always use the glove provided to control hot handles when in use.**

Your ApplePie stove uses a single lever to control the burning process, however this lever balances the air supply from three different air systems within the stove.

**Figure 1.1** shows this control located under the door. The control works by varying the amount of air which can enter the fire box. The more air that can enter the firebox the faster the fuel will burn.

The single vent control controls three types of air introduction into the firebox:

1) The Primary air is introduced via a few small holes which are visible on the back wall of the stove, just above the height of the ashpan/burn tray. This air is useful for starting the fire, when reloading new logs and in the case of a weaker chimney draught. The Primary air is introduced into the firebox when the control lever is in the 'BOOST' position, and a few degrees to the left and right of this 'BOOST' position. At all other positions of the lever arm, the Primary air is closed. When the chimney draught is sufficient and the fire is established, the control lever should be moved away from the 'BOOST' position.

2) The 'Secondary' air system allows air to enter the fire box through a channel plate at the top of the stove window. This air then flushes down the inside of the glass, keeping a blanket of air between the glass and the fire, therefore helping to keep the glass clean.

Some of this air also reaches down to the bottom of the firebed, providing fresh air to enable the wood to burn.

The Secondary air is at maximum position when the lever is between the 'BOOST' position and when pushed fully to the right.

It is at its lowest setting when the lever is pushed fully to the left.

3) The 'Tertiary air' enters the firebox via a series of horizontal holes which can be seen as you look into the stove above the rear wall.

These inlets allow fresh air to reach the upper parts of the firebox, allowing rising smoke and gases to re-ignite, and burn thoroughly and cleanly before escaping out into the flue.

The tertiary air is at maximum position when the lever is between the 'BOOST' position and when pushed fully to the right.

It is at its lowest setting when the lever is pushed fully to the left.

(To comply with the Clean Air Regulations and to ensure efficient, clean burning, the control lever is set to always allow a minimum flow of Secondary and Tertiary air so that the firebox cannot be starved of fresh air.)

## Handle Operation

Your ApplePie stove is fitted with a stainless steel handle for operation of the door. In addition your stove is supplied with a separate hardwood version - you should decide which you prefer. The metal handle will get hot during use and should be operated using the heat resistant glove provided. Each handle type simply unscrews from the upper handle mechanism. Once chosen, the handle is designed to remain in place ie. it is NOT designed to be a regularly removable handle. See **Figure 1.2**

Figure 1.2



## How does heat come out?

There are two ways in which the heat generated in your ApplePie stove will come into the room.

- 1) Radiant heat comes through the large window, and heats objects in the room
- 2) Radiant heat also comes from the body of the stove, which being made from cast iron will store some heat and continue to emit heat several hours after the fire has gone out.

## Lighting the Fire (wood burning)

Once the appliance has been correctly installed, it is ready for the first fire. We would encourage even experienced stove users to follow this guide as every stove model operates differently.

These instructions may at first seem complicated, but when followed correctly you will quickly be confident at operating your ApplePie at its optimal level safely and efficiently.

The stove needs to go through an initial period of 'running-in' in order to enable the cast iron to normalise to higher temperatures, and for the paint surfaces to cure correctly.

The stove is finished in specialist high temperature coating which is air-dry but not yet cured. The stove should be brought up to temperature gradually over the course of several fires to complete this process. If the stove gets too hot or not hot enough during this process then the curing process can fail causing issues with the paint surface.

1) For the first three fires (all on the same night), use **KINDLING ONLY**, with each burning for 15-20 minutes and each fire using approx' 400 grams of kindling. Start the second and third kindling fires whilst the fire is still warm from previous fires. Once the three kindling fires have burnt through, and whilst the stove is still warm, but slightly cooled, light a normal fire with three dry logs weighing around 1 kg in total. This fire should burn for between 45 and 60 minutes. Now allow to **FULLY COOL** naturally. - The paint should now be cured.

2) Once the curing process has been completed satisfactorily, normal fires can be lit -

Place 2 or 3 pieces of good quality solid chemical fire-lighter on the base of the stove.

3) Arrange approx' 400 grams+ of thin thoroughly dry kindling sticks (**Figure 1.3 shows 400 grams of softwood kindling next to the stove**) in an open tower shape similar to **Figure 1.4**, taking care not to assemble the fuel too close to the door glass.

**Figure 1.3**



**Figure 1.4**



- 4) Ensure air control is in the 'BOOST' position.
- 5) Light the firelighters with a long match or long lighter.
- 6) Close the door but do not lock it - leave it cracked-open (ajar) an inch or so.
- 7) The kindling should within a few minutes take light and begin to heat the flue/chimney.
- 8) When the kindling is fully alight, glowing red and with lots of flame, wait for the kindling tower to burn down and collapse, creating a bed of embers.
- 9) If it appears there is a good glowing bed of embers, proceed to *step 10*), otherwise build another stack of kindling sticks on top.
- 10) Have ready 2 or 3 pieces of seasoned dry hardwood logs (10 to 20% moisture content), weighing a total of not more than 1kg (**Figure 1.5 shows two logs weighing a total of 1kg**). Logs 200mm in length are ideal if laying

them width-ways one behind the other, or 180mm if laid side by side.

Load the logs carefully on to the hot ember fuel bed one at a time and push them down gently to make contact with the ember bed. Ensure there is an air gap between the logs. (Logs over 80mm diameter or heavier than 500 grams should be split down into smaller pieces).

**Figure 1.6** shows the logs laid in the stove.



**Figure 1.5**



**Figure 1.6**

11) Ensure logs do not extend above the clean-air inlets at the back of the firebox.

12) Close the door and leave it cracked open an inch or so.

13) Once these logs are fully ablaze and with glowing surfaces (usually 3 to 5 minutes), fully secure the door.

14) The flames will reduce to a calmer steadier burn and already your stove will be burning extremely cleanly and efficiently. If the flames die down too much and stop glowing, crack the door ajar an inch or so for a few more

minutes until the fire on the logs is fully established.

15) Once the fire is established, and to maintain an average 4kW output, the system will consume approximately 1 kg of wood per 45 minutes, but the best way to burn for clean and efficient results is to load wood 'little and often'.

16) Move the vent control fully to the right. This will close the Primary-boost air yet the Secondary and Tertiary air systems will remain open.

17) Ensure the firebox is never overloaded and when refueling always ensure logs are positioned away from the front, avoiding logs toppling over the front retaining bar. Keep logs well away from glass to ensure efficient operation of the air-wash system.

18) If the bed of embers builds up too much, allow it to burn down a bit before refueling.

19) If there is a delay when refueling, and the bed of embers has mostly burnt through, first reload with more kindling or thin logs to establish a new hot ember bed before putting on larger logs.

20) The vent control will control the speed of the burn. When attempting to slow the burn rate, ensure you move the vent control to the left, and past the boost position. As the lever approaches the central position and beyond, the air supply to the fire box will reduce.

It should always be open at least enough to ensure air-wash system has a ready supply of air and that there is constant air supply for the solid particles and gases to burn cleanly.

Your ApplePie stove is fitted with constant minimal air supply such that the appliance cannot be made airtight.

21) When you have finished using the stove for the day, fully open the vents by positioning the vent control into the 'BOOST' position, until any remaining fuel has burnt away. This final burning of the day should always be fast and hot, to help clear deposits from the glass and to minimise soot/tar and creosote deposits in the appliance and in the chimney.

22) Prior to relighting from cold, remove the bottom ash-pan/ burn-tray and dispose of most of the ashes safely. It is NOT essential to remove all ash though as some of the ash will re-burn.

23) Weather conditions including wind pattern and temperature outside along with flue design and chimney height and location will all have an effect on draught strength of your flue system which can vary from day to day.



---

Sometimes it may be necessary to use more kindling or keep the door ajar for longer when establishing a fire (when draught is weak).

Conversely you may need to close the door earlier and reduce vent openings sooner when there is a strong draught - REMEMBER - warm chimneys draw more powerfully than cold chimneys.

24) When used as a wood-burner, never be tempted to use liquid fuels.  
Never use any fuel other than dry solid wood kindling or dry-seasoned logs.

**IMPORTANT: Refueling onto a low fire-bed:**

If there is insufficient burning material in the fire-bed to light a new fuel charge, excessive smoke emission can occur. Refueling must be carried out onto a sufficient quantity of glowing embers and ash that the new fuel charge will ignite in a reasonable period. If there are too few embers in the fire-bed, add suitable kindling to prevent excessive smoke.

**Fuel overloading**

The maximum amount of fuel specified in this manual should not be exceeded, overloading can cause excess smoke.

**Operation with door left open**

Operation with the door open can cause excess smoke. The appliance must not be operated with the appliance door left open except as directed in the instructions.

**Dampers left open**

Operation with the air controls or dampers open can cause excess smoke. The appliance must not be operated with air controls or dampers door left open except as directed in the instructions.



---

### **Tips for Successful Wood-Burning:**

- Use good quality seasoned-dry logs.
- We recommend investing £10 to £20 in a digital moisture meter - Split some logs and insert the probe deep into the centre of the log.
- Do not burn anything more than 20% moisture content when measured in the centre of the log as this will have detrimental effects on heat output, ease of use, and will create excess tar, creosote and moisture which will prematurely damage your stove and flue system and could cause chimney fires.
- Never burn treated, painted, dirty wood, pallet wood or manufactured boards.
- Get the flue and belly of the fire nice and hot using a good quantity of dry kindling.
- Do not overload the stove with wood - best to load 'little and often', once the stove is up to temperature.
- Use the 'BOOST' air vent control position for a few minutes when reloading the fire with new logs or in the event of a slow or weak chimney draught, only until the stove and chimney have warmed up sufficiently.
- Use solid chemical firelighters to begin the fire, they will help establish the kindling fire well. Using screwed up newspaper to light the fire will only make your life more difficult!



# MAINTENANCE

## At least Annually.....

- 1) A minimum of once per year the flue system should be cleaned/swept by a qualified chimney sweep or suitably qualified stove installer. The servicing of the appliance can usually be carried out at the same time. Whether the system needs sweeping more frequently than this will depend on use.
- 2) Baffle plate should be removed and checked above for debris - To remove the baffle, first remove the grate and ashpan/ burn-tray then push the baffle into the roof of the stove and with one hand, hold it there - this will release the left and right side firebricks which with the spare hand can then be carefully removed in turn. The baffle can then be dropped down and manoeuvred out of the stove.  
  
Warped/misshapen baffle plates can be a warning sign that the stove has been over-fired (allowed to excessively heat on one or more occasions).
- 3) Brush the baffle using a stiff brush or wire brush to remove any deposits. Clear any debris from the upper parts of the stove above where the baffle normally sits.
- 4) Inspect firebricks on both the sides for cracks and shape distortion (caused by excessive heating) and replace if necessary.
- 5) Inspect grate and burn-tray/ ashpan for shape distortion or excessive heat damage. Replace any damaged or warped components without delay.
- 6) Vacuum or brush out the inner stove box thoroughly.
- 7) Visually check that the glass is still making a good seal against its rope on the inside of the door frame and that its retaining clips remain firmly in place to the touch.
- 8) Check that the door is making a good seal with the body of the stove all around (over time the rope will flatten out and lose some flexibility - when this happens and when it is no longer sealing fully all the way round, it needs to be replaced). The rope size used here is a 8mm-Soft type.
- 9) Blemishes or scratches to the paintwork can be touched up using a suitable high temperature stove paint in a spray can. Ensure the stove is cool and clean before applying and follow the paint manufacturer's instructions. Contact Ekol directly if you are unsure which paint to use.

## More Frequently as required....

Throughout the season, it is good practice to keep the stove in generally good clean order which will prolong the life of serviceable components and enhance the experience you have with your fire.

- 1) NEVER wipe the stove in the early stages (prior to paint fully curing), as the paint will be very soft and will damage easily.

NEVER attempt to clean or wipe the paint surface when warm or hot.

- 2) To keep the outer body clean, simply dust over with a clean soft duster when cold.
- 3) If there are marks which cannot be removed with a duster, use a slightly moistened cloth very gently, but only when the stove is cool and has not been in use. Then pat dry with absorbent paper towel. Ensure all residues are removed from the surface when using a damp cloth, otherwise paint damage / discoloration can occur when re-heated.
- 4) Regularly clear the firebox of ashes and debris using a small dustpan and brush or a vacuum but only when cool.
- 5) Regularly vacuum soot and dust from around the inside of the door and around the glass and rope seals.
- 6) If glass gets dirty on the inside from soot, clean with liquid 'stove glass cleaner' and a soft cloth OR with an "Atmosfire Dry Wiper" produced by Schott (the manufacturers of ceramic stove glass) and available online. Do this as soon as possible once the soot appears, but only when the fire is completely cool. Never use newspaper or soot or any other abrasive or cleaning method on the glass.

## The Clean Air Act

### **The Clean Air Act 1993 and Smoke Control Areas:**

Under the Clean Air Act local authorities may declare the whole or part of the district of the authority to be a smoke control area. It is an offence to emit smoke from a chimney of a building, from a furnace or from any fixed boiler if located in a designated smoke control area. It is also an offence to acquire an “unauthorised fuel” for use within a smoke control area unless it is used in an “exempt” appliance (“exempted” from the controls which generally apply in the smoke control area).

In England appliances are exempted by publication on a list by the Secretary of State in accordance with changes made to sections 20 and 21 of the Clean Air Act 1993 by section 15 of the Deregulation Act 2015. Similarly, in Scotland appliances are exempted by publication on a list by Scottish Ministers under section 50 of the Regulatory Reform (Scotland) Act 2014. In Northern Ireland appliances are exempted by publication on a list by the Department of Agriculture, Environment and Rural Affairs under Section 16 of the Environmental Better regulation Act (Northern Ireland) 2016. In Wales appliances are exempted by regulations made by Welsh Ministers.

Further information on the requirements of the Clean Air Act can be found here:  
<https://www.gov.uk/smoke-control-area-rules>

Your local authority is responsible for implementing the Clean Air Act 1993 including designation and supervision of smoke control areas and you can contact them for details of Clean Air Act requirements.

The “ApplePie by Ekol” free-standing stove has been recommended as suitable for use in smoke control areas when burning wood logs. A factory-fitted modification to the air controls has been implemented to ensure a minimum opening of the secondary air and also for the tertiary air.

# Installation Instructions

As every installation is unique, it is not possible to provide a step by step guide to cover the entire installation. The intention of these instructions is to provide basic information for use by suitably trained Competent Persons.

This guide will help identify the key points to observe when fitting the ApplePie.

All installations need to be carried out in compliance with local and national Building Regulations and relevant authority guidelines.

*Approved Document J is important for England and Wales and can be downloaded at:*

<https://www.planningportal.co.uk/info/200135/approved-documents/72/part-j-combustion-appliances-and-fuel-storage-systems>

## The following standards may also be relevant:

*BS 6762-2:1991 – Services for leisure accommodation vehicles and transportable accommodation units. Code of practice for the installation of solid fuel fired heating in park homes and transportable accommodation units*

*BS 8511:2010 – Code of practice for the installation of solid fuel heating and cooking appliances in small craft*

In addition, HETAS may be able to provide advice and training when installing into non-permanent or holiday accommodation.

## Unpacking & Manoeuvring

This stove is heavy and requires at least 2 able bodied people to lift, and may need more depending on optional body extras (such oven and pedestal base).

Ensure that the stove and its constituent parts are never dragged across the floor and are lifted carefully into position.

A two wheeled 'sack trolley' or lifting trolley may be helpful or necessary.

Inside the stove you will find several components:

- 1) HeatResistant Glove
- 2) User Manual
- 3) Cast Iron Flue Collar with 3x Fixing Screws
- 4) Pizza/Griddle cook shelf (**always remove before lighting fire and only replace above a bed of embers once all flames have died (if intending to cook on).**)

5) Multi-tool for ash-pan/ burn-tray and pizza cooking shelf removal.

6) Grate with separate log retaining bars

7) Ash-pan/ burn tray

8) Spare hardwood handle

## Pre Install Checks

1) Check that the door handle mechanism locks the door securely. Door seals can easily be checked at anytime by tearing a small piece of paper. Trap the paper in the door and secure the door. If the paper is easily pulled out without resistance, the rope seal in that particular area needs 'plumping out' - do this by pinching the rope and gently puffing it outwards. At some stage in the future the rope will be flattened so much that it will need replacing with a fresh rope seal.

2) Check the smooth operation of the vent controls - if there is friction or a non-smooth movement or jamming, it is possible there is residue from steel shot blasting in the vent mechanism - in this case, remove the grate, pizza shelf and ashpan from the inside of the stove. On the floor of the stove you will see a plate held in place with four fixings. remove this for inspection access as it is above the vent mechanism. Insert a vacuum cleaner nozzle into the inspection access whilst swiftly moving the vent control left and right several times. (**Figure 2.1**)

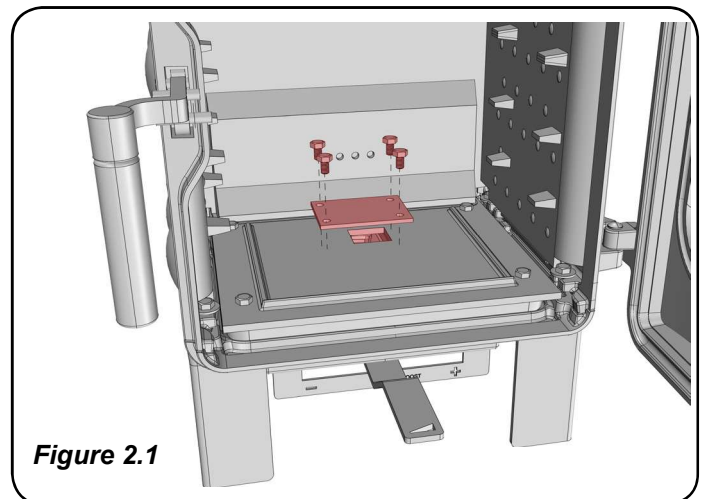

**Figure 2.1**

3) Check that the inside door glass is correctly in position, making a seal on its rope and that the fixings are not loose, but hand tight (never over-tighten glass retaining clips).

4) Check that the baffle plate above the burn area inside the firebox is in position - it should be firmly located resting on top of the firebrick plates to the sides, and pushed

backwards, leaving a smoke escape gap at the front of the plate just behind the top of the door frame.

5) Check that the intended location of the stove is safely accessible and that all adjacent walls, floors and objects (adjacent to the stove) and their substructures (ie. stud walls) are either fully non-combustible or are located beyond the minimum clearances required (See '*Distances to Combustibles*' - on pages 18+ (diagrams illustrating distances to combustibles in relevant scenarios).

6) Check that the hearth and its substructure are suitably strong and stable if taking the weight of the stove. The hearth needs to be made of suitable non-combustible material.

7) Ensure the hearth is compliant with relevant Building Regulations or any HETAS or British Standards installation guidelines relating to the specific structure type, for example if being installed into a boat or cabin, glamping pod etc

To comply with domestic Building Regulations in England and Wales, the aesthetic hearth needs to be a minimum 12mm thick, needs to extend at least 150mm either side of the appliance, and at least 225mm in front of the appliance.

8) Chimney/Flue -

a) The flue system should be checked for draught strength - a minimum flue draught of 10Pa is required, and a maximum of 20Pa, measured approximately 500mm above the stove flue collar via a pre-drilled draught gauge access in the first section of flue pipe. This measurement should be taken when the flue is pre-warmed. Flue systems of excessive strength should be fitted with a balanced 'flue draught regulator'.

b) A flue system of 4.5 metres height (from the top of the stove) would normally provide 'standard' or 'mid-range' draught strength when using insulated 5" internal diameter flue (assuming there are no other external factors which counteract the flue draught strength).

c) Any flue system fitted in a domestic dwelling or commercial building needs to be compliant with the current England and Wales Building Regulations specifications for a Class1 Chimney. Existing brick and clay-lined chimneys should be fitted with a suitable stainless steel liner ideally of 5" (125mm) diameter. The maximum internal flue diameter used should be 6" (150mm). Suitable insulation between the inner walls of the chimney and the liner should be used.

Additional information for small space/ 'glamping' and boat installations:

When installed into small spaces such as tents, yurts, cabins, sheds and other alternative non-permanent non-

domestic structures, we recommend using 4" insulated chimney system and a minimum 3m flue height.

See specific guidelines published by HETAS for installation into this type of accommodation.

9) Ventilation - The appliance requires room ventilation when used as a wood-burner. - This is air which is drawn from the outside to replace air in the room consumed by the burning of the fire. Houses built before 2008 are likely to have enough natural ventilation to supply this air, unless the house has had extensive draught proofing works carried out. For more modern houses or those with minimal natural ventilation (air permeability less than 5.0 m<sup>3</sup>/h.m<sup>2</sup>), an air vent with equivalent-free-surface area of at least 2750mm<sup>2</sup> needs to be used. In any case, additional rules for vents apply when fitting the system with flue draught stabiliser (if in doubt consult either HETAS, Building Regulations Document J, or your engineer).

For well insulated or well sealed small spaces such as cabins, glamping pods, boats etc, ensure adequate ventilation to the space or use the direct air supply option connecting the back of the stove to the outside. - See section in this manual on installation of external air connection.

10) CO Alarm, -The fitting of a CO alarm is an essential requirement and should be fitted in the same room as the stove. Existing alarms should be checked for current suitability. If in doubt fit a suitable good quality new alarm.

## Attaching Flue Collar etc.

### Flue Outlet:

The stove has the option of having a top or rear vertical flue outlet.

#### Option 1: Top outlet:

When using the top flue connection, remove the top blanking plate via the 3x fixings. Replace this with the cast iron collar found inside the stove. Ensure the attached rope seal on the Flue-Collar is compressed and making a good seal. Tighten the 3x fixings. If in doubt, use a bead of fire cement to enhance this seal.

Alternatively, when using the top outlet with (optional) EKOL supplied 'Direct to Stove-top Twinwall Adaptor', the adaptor will take the place of the cast iron collar. See **Figure 2.2.1**

**Figure 2.2.1**

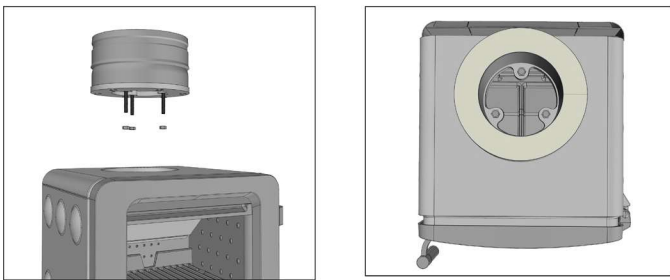

Ensure the rectangular blanking plate on the rear of the stove behind the heatshield is in place. See **Figure 2.2.2**

**Figure 2.2.2**

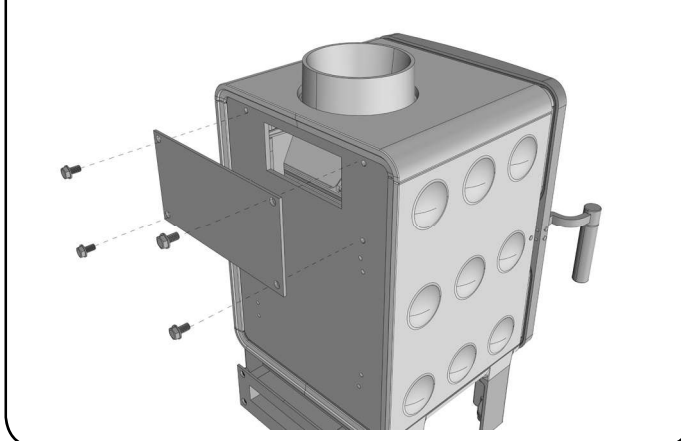

#### Option 2: Rear vertical outlet:

If using the rear vertical flue accessory option, first ensure the top circular blanking plate is already in place on the top of the stove.

Remove the heat-shields from the rear of the stove via the four bolt fixings. If the rectangular blanking plate is still in

place on the back of the stove, remove it via its four fixings. Replace it with the rear vertical flue collar, using EITHER a bead of suitable high temp silicon OR a flat self adhesive ceramic stove rope tape as a gasket. Insert the bolts with nut and washer and tighten the nut to secure the rear flue adaptor to the stove body. NOTE; If using the 'Baked Apple' (with top oven) and you intend to use 4" twin-wall directly off the rear vertical flue outlet, (see **Figure 2.2.3**)

**Connection of (optional) Rear Vertical Flue Adaptor**

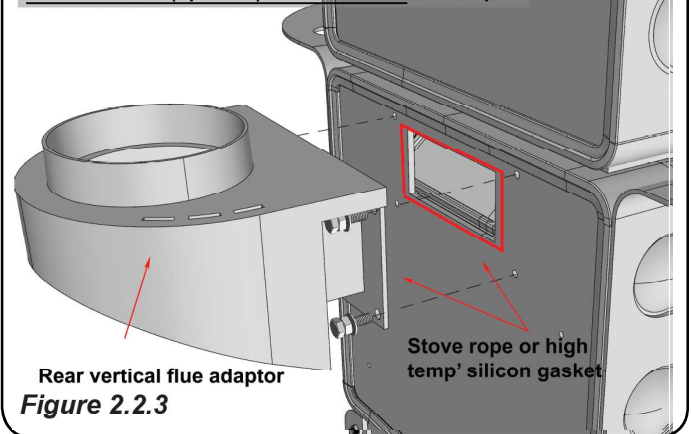

Remove the 'snap out' sections of the inner and outer heatshield as shown on **Figure 2.2.4** then replace the heatshields.

**Figure 2.2.4**

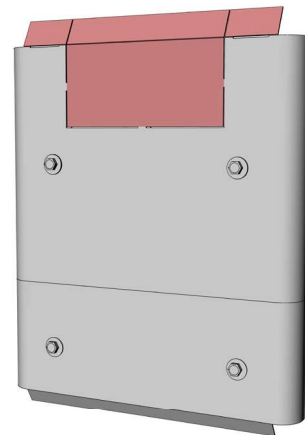

## Connecting the (optional) top oven

When the top oven is ordered at the same time as the stove ('Baked-Apple' or 'Baked-Apple-Stack') the top of the stove will have been pre-drilled and tapped ready to accept the top oven. Simply attach the oven to the top of the stove using the bolts supplied taking care not to over-tighten the bolts. (See **Figure 2.3**)

If you are fitting the top oven as a later addition, the top of the stove will need to be drilled and tapped. Align the oven

accurately on top of the stove so that the front doors of stove and oven are aligned, as well as the side accurately aligned.

Mark with a permanent 'Sharpie' type marker through the centre of each of the oven attachment holes marking onto the stove top.

Remove the top oven and carefully drill each of the four holes with a 5mm drill bit, taking care to accurately drill centrally to the marked position for each hole. Ensure to only drill through the first layer of cast iron.

Using a tap-handle and 6mm (x1) tapping tool, carefully thread each hole.

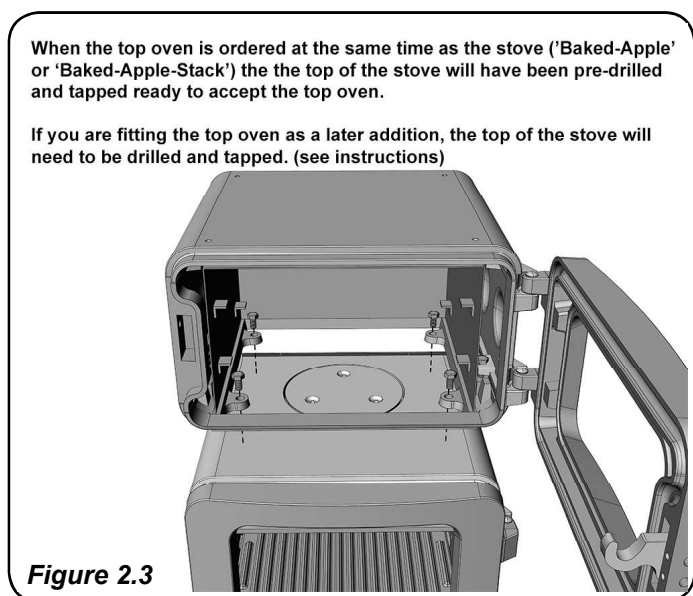

### Connecting to External Air (option)

The ApplePie stove can as an option be fitted with ducting from the rear to an external air supply outside of the building.

To enable connection to round ducting, the optional external air (plenum) box must first be fitted. This simply bolts to the rectangular air inlet on the rear of the stove and seals with a self adhesive rope gasket, see **Figure 2.4.1**

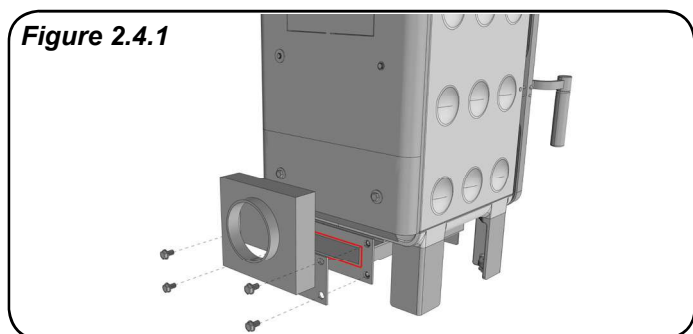

Either circa 3"(75mm) or 4"(100mm) ducting can be

used. Ducting would most commonly be flexible single skin aluminium but any steel rigid flue could also be used however it must have anti-corrosive properties.

We do not recommend the use of ducting more than 3 metres in length.

**When using flexible ducting less than 80mm diameter, the ducting should be inserted into the connector on the back of the stove: (Figure 2.4.2)**

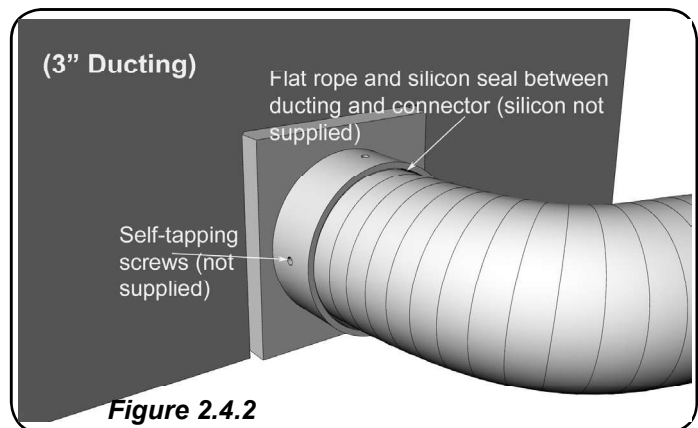

- 1) Apply a layer of flat self-adhesive ceramic fire rope around the end of the ducting and insert it into the connector.
- 2) Using some 15mm self-tapping or 'tek' screws, screw through the holes on the connector biting into the ducting.
- 3) Finish the seal with a bead of high temperature silicon between the edge of the connector and the ducting.

**When using larger sized ducting, the ducting will go over the connector on the back of the stove: (Figure 2.4.3)**

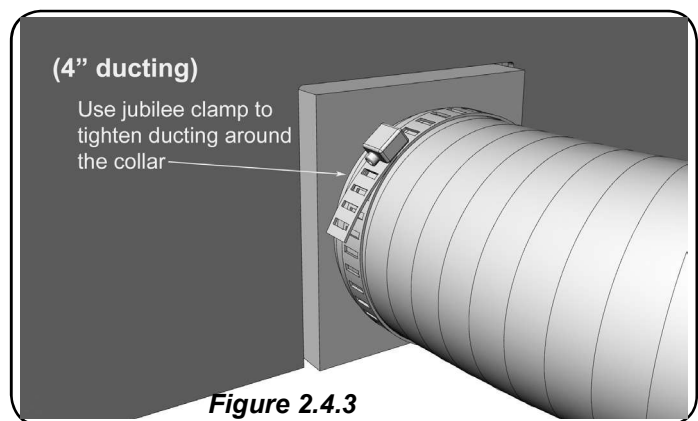

- 1) If there is space between the inside diameter of the ducting and the outside diameter of the stove connector, apply a layer of flat self-adhesive ceramic fire rope around the stove connector.
- 2) Carefully feed the end of the ducting over the connector until it is firmly in place.

3) Use the jubilee band to tighten the ducting to the connector.

4) The optional External Air Kit from Ekol also includes a cowl with built in anti-insect mesh, to be used on the outside wall. The ducting can be secured to this cowl with the built-in clips and self-tapping or 'tek' screws. It is crucial that rainwater or any excess moisture must NOT be allowed to enter the ducting/stove air system.

5) Ensure that the ducting is not damaged nor overly kinked along its route.

### Connecting the (optional) side plates

**If you ordered your ApplePie with one or both side warming plates** then we will have pre-drilled and tapped the side of the stove body for you, ready to receive the plate/s. The fixings will be in place already, you will just need to unscrew them, offer up the side plate and re-attach the screws with an allen key, taking care not to over-tighten them.

**If you are fitting the side plates retrospectively** then you may need to drill the fixing holes and tap (thread) them. First offer up the side support plate to the correct side of the stove. Line up the plate so that the top is level with the cast iron top of the stove, and so that each circular hole in the plate aligns with its cast iron circular 'lump'.

Without moving the plate, use a sharp piece of chalk, a scribe or a 'Sharpie' type marker pen to mark each of the four fixing holes. Remove the plate.

Using a 5mm new drill bit, carefully drill each hole through the outer shell of the stove.

Use a tap-handle with M6 (x1) tap to thread each hole. The side plate is now ready to attach. Do not over-tighten. See **Figure 2.5**

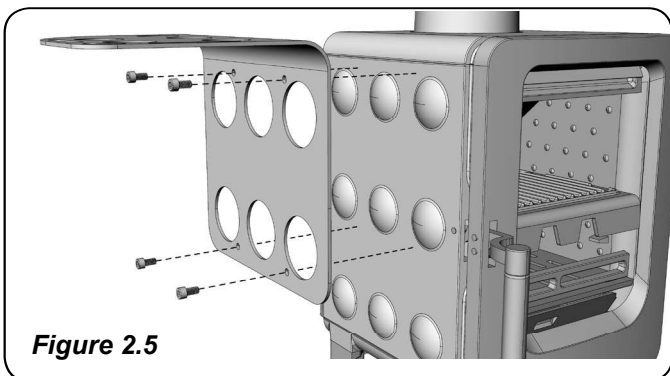

**Figure 2.5**

### Connecting the (optional) top rail guard

To install the optional top rail / guard (often used on boats to stop pans falling from the stove top), first remove the heat-shields on the back of the stove.

Using the allen head cap screw fixings provided, attach the top rail (**Figure 2.6**)

Replace the rear heat-shields.

#### Top rail/ guard (optional attachment)

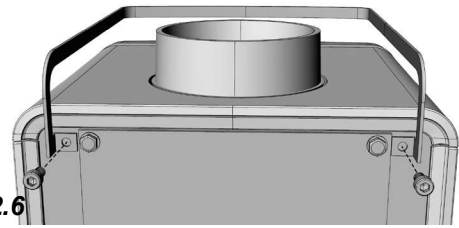

**Figure 2.6**

### Connecting the (optional) pedestal

In order to connect the ApplePie stove to its optional pedestal base, you first need to disconnect the standard 4x legs:

Carefully lift the stove door off it's hinges by gently tapping the underside of the hinge pins then lifting the door up. Remove the ashpan, grate, pizza shelf and other loose items from within the stove. With some help, carefully lift the stove onto its head (upside down), placing it on a clean surface.

Remove the 4x nuts which hold the legs in place, but keep the threaded bars in place.

The pedestal has two thin steel brackets fixed to the top. These are for transport only and can now be removed.

Lift the pedestal upside down on to the bottom of the up-turned stove, locating it on the 4x threads sticking out from the stove base.

Align the stove with pedestal and loosely fit the bolt threads with washers and nuts by hand only (**Figure 2.7**). Check visually that the pedestal sides, front and back are well aligned with the stove above.

**If necessary, the bolts which hold the panels of the pedestal can be loosened to allow better alignment of the pedestal relative to the stove body, then re-tightened (don't over-tighten).**

Once happy with alignment, the four fixing bolts can have their nuts tightened so that the pedestal and stove are properly attached.



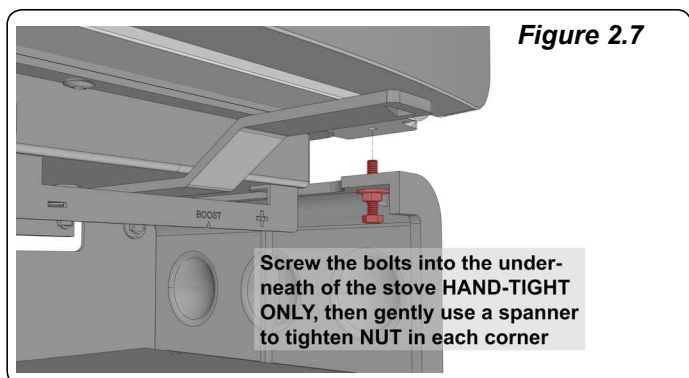

**Figure 2.7**

## Securing the stove to the floor

Sometimes it is necessary to secure the stove to the floor/hearth. This would normally be necessary where there is likelihood of movement such as on board a boat, or if there is likely to be a danger of the stove being moved or pushed.

An optional floor-fixing-bracket-kit is available if required. The kit consists of steel brackets which attach via the leg leveling threads. The other end of the bracket can then be fixed to the hearth / floor or enclosure using suitable fixings. There is an 8mm wide elongated hole at the floor fixing end of the bracket. Fixings to the floor are not provided as these need to be chosen to suit the floor/ hearth substrate material.

To attach bracket to the stove leg, carefully lift the stove on to its back then remove the M8 leg leveling bolt from each leg.

Re-attach the bolt but this time place the bracket and 1 or 2 spring washers onto the bolt first. (See **Figure 2.8**)

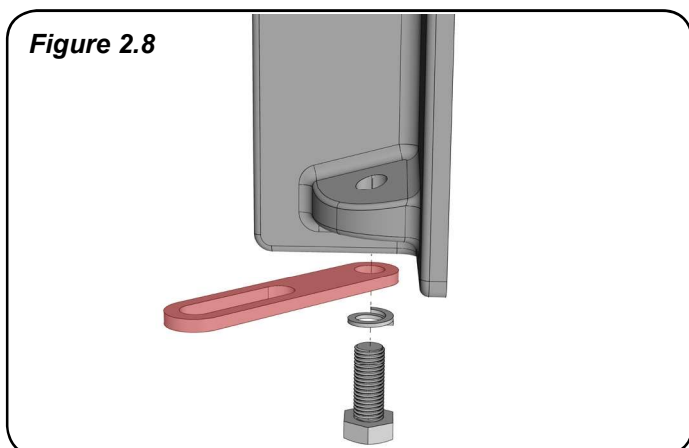

**Figure 2.8**

When using the optional enclosure system, if the adjacent walls will be combustible, then all distances to combustibles specifications need to be met - see the "Distances to Combustibles" section in this manual.

The enclosure comes with four adjustable feet which can be used to ensure the enclosure sits level.

On the rear of the enclosure there are circular panels which can be 'knocked out' to provide a route for external air connection if required.

The enclosure, when ordered at the same time as the stove, will come with the relevant flue support bracket, - there is a long support or a short support, depending on whether the stove will use the top flue outlet, or the rear vertical flue adaptor. (The short bracket is for use with the rear vertical flue adaptor and the longer bracket is for use with the top flue outlet).

The use of the bracket is not essential and would only be used if connecting a length of single skin flue first to provide additional rigidity / support to the pipe.

In the event that the bracket is not used, it should still be utilised during installation as a guide to help position the stove correctly relative to the enclosure.

See also **Figure 2.9** to help achieve the correct position of the stove. The rear vertical flue adaptor at the back of the stove should not be touching the enclosure.

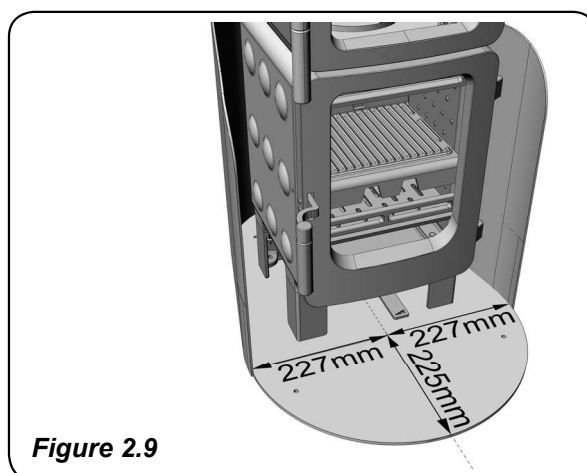

**Figure 2.9**

## Using the Optional Enclosure System



# DISTANCES TO COMBUSTIBLES

The ApplePie stove has been extensively tested to establish safe distances to combustible surfaces. These surfaces would normally be adjacent walls, but the same principles need to be applied to any combustible object near to the stove.

**The following distances need only be observed when there are combustible surfaces around the stove.** They do not apply if all adjacent surfaces are solid non-combustible and of suitable thickness.

## When NOT using the optional enclosure system:

**Scenario A)** Stove is backed up towards a wall, using twin-wall insulated flue all the way, and using rear vertical flue adaptor: see **Figure 3.1.1**

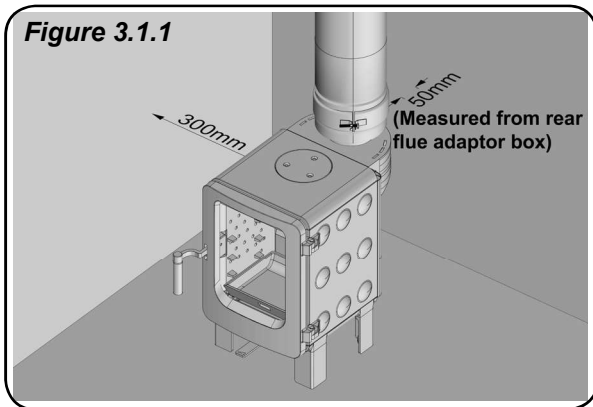

**Scenario B)** Stove is backed up towards a wall, starting with single skin pipe, and using rear vertical flue adaptor: see **Figure 3.1.2**

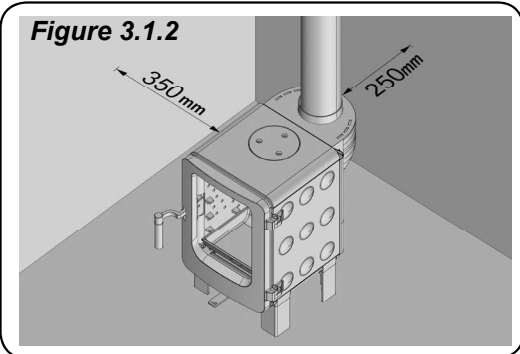

**Scenario C)** Stove is backed up towards a wall, using twin-wall insulated flue all the way, and using top flue outlet: see **Figure 3.1.3**

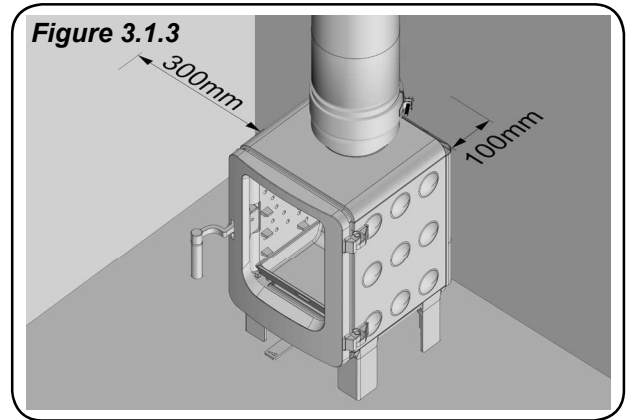

**Scenario D)** Stove is backed up towards a wall, starting with single skin pipe, and using top flue outlet: see **Figure 3.1.4**

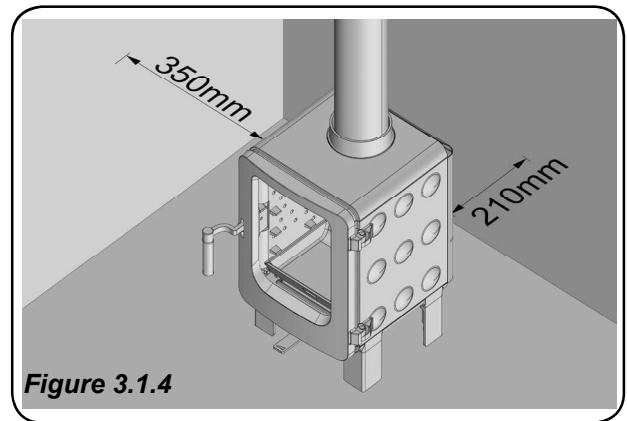

**Scenario E)** Stove is in a corner position at 45degree angle to each adjacent wall, using twin-wall insulated flue all the way, and using rear vertical flue adaptor: see **Figure 3.1.5**

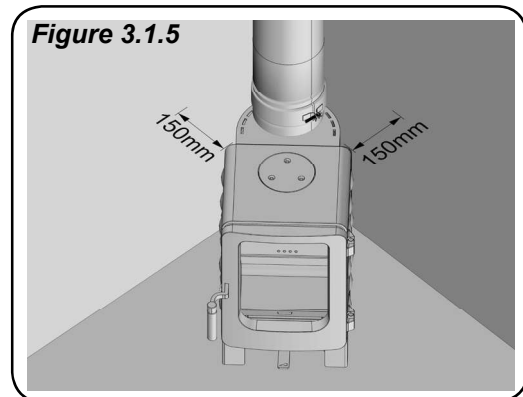

**Scenario F)** Stove is in a corner position at 45degree angle to each adjacent wall, using twin-wall insulated flue all the way, and using top flue outlet: see **Figure 3.1.6**

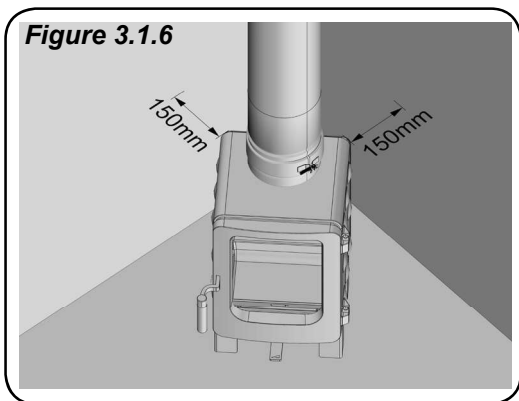

**When using the optional enclosure system:**

**Scenario G)** Stove in enclosure system using rear-vertical flue adaptor and 4" twin-wall insulated flue. Enclosure is orientated towards a wall behind: see **Figure 3.2.1**

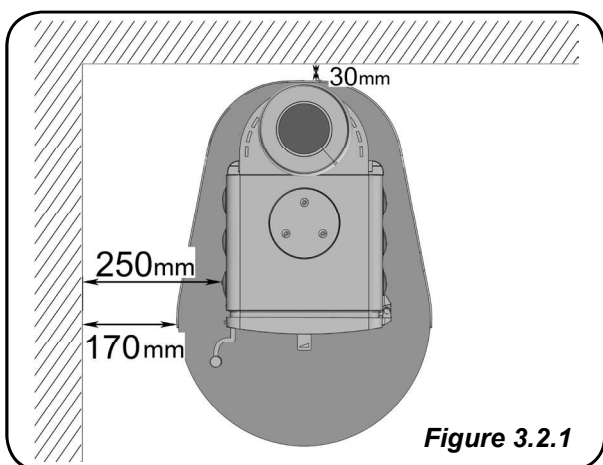

-If it is necessary to use a short length of single skin pipe first, then the distance to rear of enclosure, from the wall should be increased to 50mm minimum. See **Figure 3.2.2**

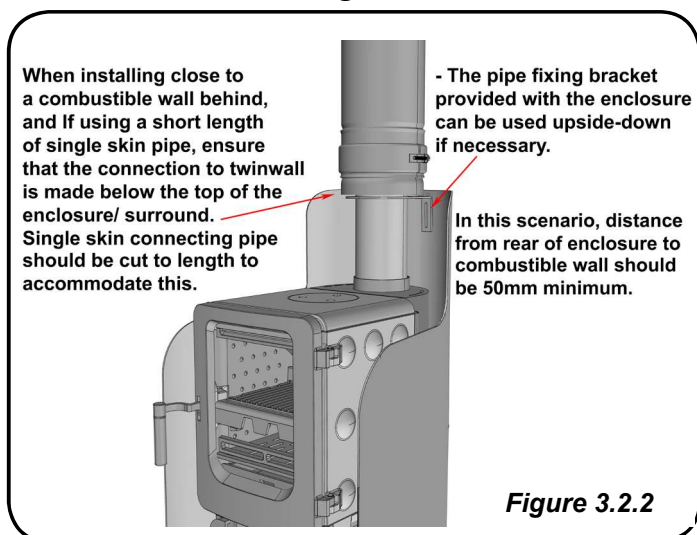

**Scenario H)** Stove in enclosure system using rear-vertical flue adaptor and either single skin or insulated flue. Enclosure is in a corner position at 45 degree angles to each wall: see **Figure 3.2.3**

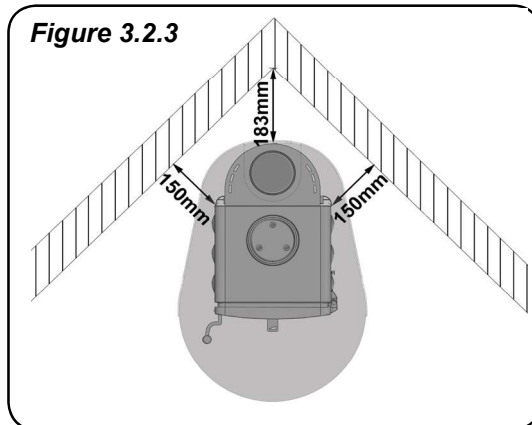

**Scenario I)** Stove in enclosure system using top flue outlet and either single skin or insulated flue. Enclosure is in a corner position at 45 degree angles to each wall: see **Figure 3.2.4**

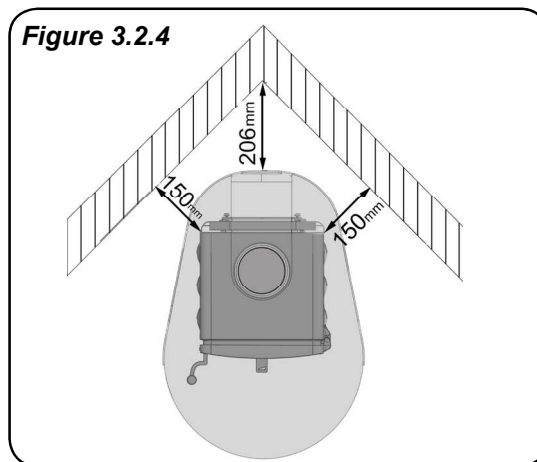

**When there is a requirement to position the stove closer than these minimum clearances from combustibles:**

In the event that the above safe distances to combustibles cannot be achieved, additional heat-shields can be attached to the wall, allowing the stove to sit much closer to adjacent walls.

Consult your installer, speak to Ekol, or consult the relevant HETAS guidance.



## Hearth Requirements

### When using the ApplePie in the enclosure:

When using the optional enclosure, ensure the stove is centrally placed in the enclosure with equal distances to left and right between stove body and enclosure walls.

Use the enclosure flue-pipe-bracket supplied wherever possible (NOT used when insulated flue comes all the way to the stove flue outlet).

This bracket ensures correct distance between the stove and the rear of the enclosure.

The base of the enclosure at the front needs in any case to be a minimum of 225mm in front of the stove.

If the enclosure is sitting on a combustible floor surface, a 12mm fireproof board such as calcium silicate or cement board should be cut to shape and placed under the enclosure - include 4x cut outs for the leg levelling feet.

### Without optional enclosure:

The stove should be sat on a solid non-combustible hearth material of at least 12mm thickness, projecting a minimum 225mm in front of the stove and 150mm either side of the stove.

When fitted in a house or other permanent domestic dwelling in the UK, consider additional UK Building Regulations.

When installed on a boat, the optional *Ekol--Pie-Boat-Enclosure* system can be used as a complete hearth. Alternatively refer to **BS 8511:2010 Code of practice for the installation of solid fuel heating and cooking appliances in small craft.**

## Flue/Chimney Connection

**We recommend that the ApplePie stove is installed with a minimum flue height of 3metres, measured from the top of the stove at the flue outlet. It may be possible to install on slightly shorter flue heights but weakened flue draught will result. In this case consult with a chimney expert at the design stage.**

Due to the high efficiency of modern, clean-burning stoves, we recommend a flue system be well insulated to avoid cooling of the flue gases, flue condensation and reduced draught strength.

Horizontal runs of flue cannot be used. Bends and offsets should be kept to a minimum with bends being ideally 30° (150°) and a maximum 45° (135°).

If using a short length of single skin connecting pipe off the top of the stove, this should convert to the main flue system as soon as possible.

A method of simple disconnection from the stove should always be incorporated - this could for example be via an adjustable / telescopic length of flue.

Flues should always terminate a minimum 1.8 metres above any **combustible** roof surface.

### Scenario 1) Connecting to an existing Class1 (usually brick/block/masonry) type chimney:

The first length of pipe from the top of the stove should be either suitable stainless steel or vitreous enamel rigid pipe, in 4" (100mm) diameter.

In order to comply with domestic UK Building Regulations, a minimum 5" flue system should then be used. We do not recommend using larger flues unless adequate draught strength can be assured.

This type of chimney should be re-lined with suitable 5" diameter stainless steel liner. Insulating around the liner with suitable material will ensure a stronger, more consistent flue draught with reduced condensation.

In this type of installation we recommend a target flue height of 4.5 metres + above the stove flue outlet.

**Scenario 2) Installation without existing chimney into temporary accommodation such as yurt, glamping pod, timber cabin etc:**

Short flues and structures that are naturally poorly insulated (such as tents) will have a naturally weaker draught strength than taller flues in better insulated buildings. Some of this reduced draught can be mitigated by ensuring the flue gases stay as hot as possible until they exit the flue. This can be achieved using an insulated flue system for the entire length or as much as the length as is possible in the case of using a short single skin pipe off the stove first.

Once the flue becomes insulated, under no circumstances should the flue revert to non-insulated pipe higher up.

Flue systems need to be fully self supporting via appropriate support brackets.

In scenarios such as bell-tents, the lack of available rigid fixing points requires a suitable alternative such as a guy-wire system or a vertical post to be rigidly fixed to the ground and positioned close to the flue. Support clamps can then be secured to this independent post structure.

### Scenario 3) Boats:

Most of the same principles apply to boats when compared to low-height temporary accommodation - however additional guidelines available from document *BS8511:2010* should be observed.

Generally boats are very well sealed and generally have limited living space therefore ventilation and efficient evacuation of the flue gases in boats are of crucial importance.

Increased flue length and the use of suitable insulated flue on a 4" (100mm) diameter system will help ensure stronger flue draught strength.

### Scenario 4) Domestic/ permanent dwelling without existing chimney (using pre-fabricated insulated chimney):

When installing into a single storey building or extension, a minimum 3m flue height from top of stove should be observed. In the event of bends and offsets being required, this will weaken the flue draught and additional flue height may need to be added to compensate.

Suitable 5" internal diameter insulated flue should be used in this scenario, with maximum 1.5m uninsulated stove pipe connection, either in 4"(100mm) or 5"(125mm) diameter (using suitable 4-5" increaser at the stove outlet.

## Cooking

Your ApplePie stove comes as standard ready to cook in various ways using the internal (removable) cookshelf which has a flat side for pizza cooking and a griddle side for steaks, griddled vegetables etc.

Cooking on here as well as on any of the optional add-on cook options, with a bit of practice will reward you with some amazing food and an experience unrivalled on any regular domestic oven.

There are however more variables, specifically temperature control, which will require a little understanding and practice.

When using the direct-firebox method with included pizza/griddle shelf, internal temperatures will be anywhere up to 350°C - substantially hotter than a regular domestic oven, and closer to the temperatures of a commercial wood-fired pizza oven - Food at this temperature will cook quickly!

Additional pizza stones can be used on top of the plate to allow more even cooking of the pizza or breads. Alternatively, wait until the firebox temperature has reduced and breads can be cooked direct on the cast iron plate without burning the bottom.

To prepare the stove for cooking with the shelf, first light a kindling fire followed by four small logs (around 200grams per log). After around 35 minutes the logs should tamp down and break up easily when hit gently with a poker.

Once all the flame has gone and the wood burnt through, with glowing hot embers, the firebox should be ready to insert the shelf onto the lowest available shelf support lugs - Wear the heat resistant glove to do this and take care to position the shelf correctly so it is neither too far forward nor too far back (see **Figure 4.1**)

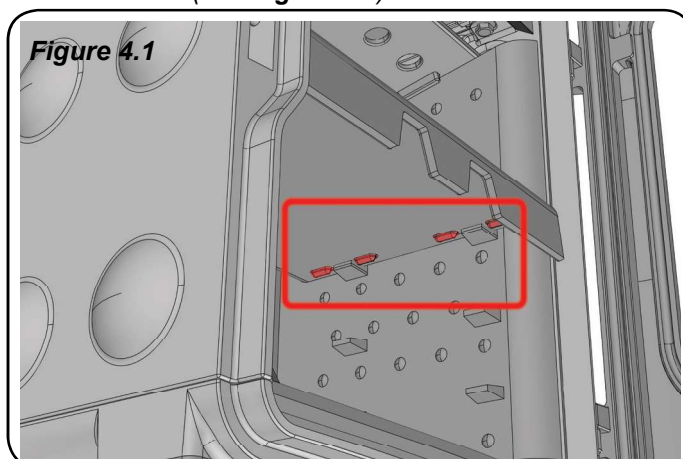

Secure the door and wait 5 minutes. The cook plate should now be up to temperature - We recommend the use of a digital-laser-thermometer to help learn ideal cooking



temperatures and this will fine tune your wood-fired cooking skills.

Use a suitable implement (such as pizza paddle) as well as heat resistant glove or mitt to place the food onto the cook shelf.

For food such as raw meat, we suggest using a digital meat-thermometer probe to ensure safe cooking.

Ekol can supply pizza paddles for example, correctly sized for the Pie stove to make the perfect 8" pizza.

It is important to avoid excessively fatty foods such as burgers and fatty meats as this will smoke and spit, leaving deposits inside the stove and on the glass. Never use oil to cook on the plate as this will create a lot of smoke at such high temperatures.

Typically a pizza can be cooked in around 2 to 5 minutes depending on internal firebox temperatures and dough thickness. Go easy on the pizza toppings! Too much sauce or moisture in the toppings will make your pizza dough soggy in the middle.

If cooking for a lot of people or if cooking something which takes a long time such as when using a Dutch oven inside the stove, the temperature can be kept up by using small stick wood or smaller pieces of well split logs, one or two at a time. - It is important NOT to add large fuel loads once the cook shelf is in place.

Once cooking is finished, if you intend to refuel the stove for heating, you will need to first carefully remove the cook-shelf and place it somewhere safely - DO NOT quench the hot cast iron plate straight into water as you risk cracking it. First let it cool fully.

### Using top oven on "Baked Apple"

The top oven option although smaller (think portion control!) will be more similar to a regular domestic oven in terms of cooking temperatures. It also will not have the 'smoky wood' flavour compared to cooking directly in the firebox.

Being a heavy cast iron construction, the stove will need to be on and well fuelled for at least an hour or so before the top oven is up to around 200°C internally.

Light your fire in the normal way and refuel as required. Again, using a digital laser thermometer will help the internal cooking temperatures.

Refuel the firebox as necessary to keep the top oven up to temperature.

### Using optional Top cook/warming plate

When specified on an "Apple Core" or "Apple Stack" (without top oven), the optional stainless steel plate will under normal firing conditions get hot enough to boil a pot of water or to cook on using for example a 'Dutch-oven'.

To achieve full temperature on the plate, the stove would normally have been in use for 1 hour +.

Cooking food directly onto the plate without pots/ pans is NOT advised as it will make a mess and could damage paintwork.

Pat dry (but DON'T RUB!) the stove top/ body immediately if there are any liquid spills.

When cooking using the top plate, we recommend the use of heavy cast iron pots/ pans or heavy copper based pans for maximum heat absorption, retention and for even heat distribution.

Cast iron Dutch ovens (cast iron pot with cast iron lid) are great for slow-cooking roasts and casseroles).

When a top plate is specified with a top oven ("Baked Apple" or "Baked Apple Stack"), then the plate is only expected to be a warming plate and is unlikely to get hot enough to boil a kettle or to cook on.

See [www.applepiestove.com](http://www.applepiestove.com) for recipe ideas - we will keep adding to these constantly for your inspiration! If you have your own recipes or beautiful images of cooking with your ApplePie stove, please email them to us for a chance to win prizes in our regular photo competitions!

# ApplePie Exploded View / Spare Parts

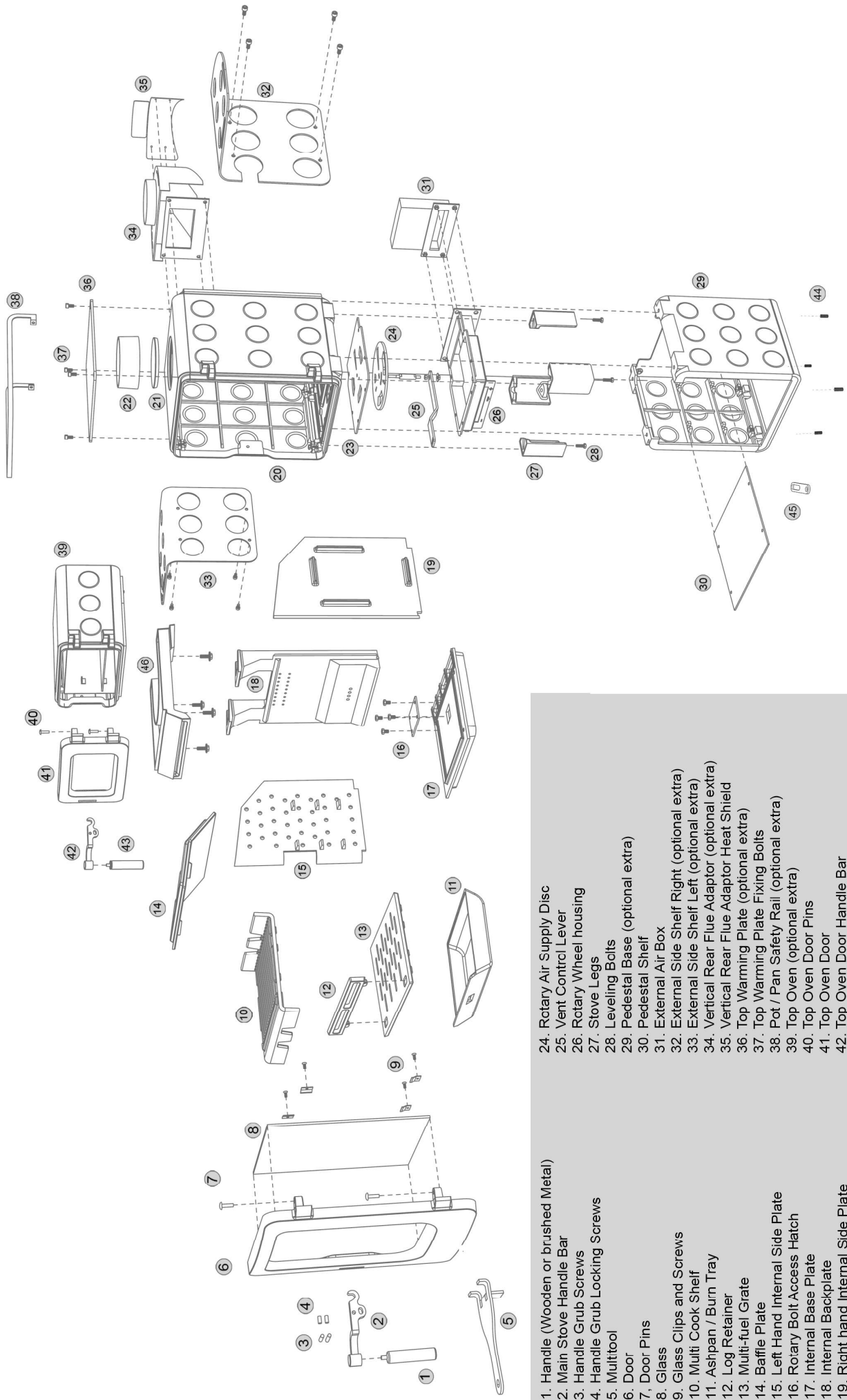

- 1. Handle (Wooden or brushed Metal)
- 2. Main Stove Handle Bar
- 3. Handle Grub Screws
- 4. Handle Grub Locking Screws
- 5. Multitool
- 6. Door
- 7. Door Pins
- 8. Glass
- 9. Glass Clips and Screws
- 10. Multi Cook Shelf
- 11. Ashpan / Burn Tray
- 12. Log Retainer
- 13. Multi-fuel Grate
- 14. Baffle Plate
- 15. Left Hand Internal Side Plate
- 16. Rotary Bolt Access Hatch
- 17. Internal Base Plate
- 18. Internal Backplate
- 19. Right hand Internal Side Plate
- 20. Main Stove Body
- 21. Blanking Plate
- 22. Collar
- 23. Rotary Plate

- 24. Rotary Air Supply Disc
- 25. Vent Control Lever
- 26. Rotary Wheel housing
- 27. Stove Legs
- 28. Leveling Bolts
- 29. Pedestal Base (optional extra)
- 30. Pedestal Shelf
- 31. External Air Box
- 32. External Side Shelf Right (optional extra)
- 33. External Side Shelf Left (optional extra)
- 34. Vertical Rear Flue Adaptor (optional extra)
- 35. Vertical Rear Flue Adaptor Heat Shield
- 36. Top Warming Plate (optional extra)
- 37. Top Warming Plate Fixing Bolts
- 38. Pot / Pan Safety Rail (optional extra)
- 39. Top Oven (optional extra)
- 40. Top Oven Door Pins
- 41. Top Oven Door
- 42. Top Oven Door Handle Bar
- 43. Top Oven Door Handle (Wooden or brushed Metal)
- 44. Pedestal Levelling Bolts
- 45. Floor Fixing Bracket (optional extra)
- 46. Internal top air channel plate



# Service Records (to be completed by Service Engineer)

## 1st SERVICE

Date of Service:.....

Next Service Due:.....

Details of Service work completed:

Signed:.....

Dealer's Stamp/HETAS Registration Number:

## 2nd SERVICE

Date of Service:.....

Next Service Due:.....

Details of Service work completed:

Signed:

Dealer's Stamp/HETAS Registration Number:

## 3rd SERVICE

Date of Service:.....

Next Service Due:.....

Details of Service work completed:

Signed:

Dealer's Stamp/HETAS Registration Number:

## 4th SERVICE

Date of Service:.....

Next Service Due:.....

Details of Service work completed:

Signed:

Dealer's Stamp/HETAS Registration Number:

## 5th SERVICE

Date of Service:.....

Next Service Due:.....

Details of Service work completed:

Signed:

Dealer's Stamp/HETAS Registration Number:

## 6th SERVICE

Date of Service:.....

Next Service Due:.....

Details of Service work completed:

Signed:.....

Dealer's Stamp/HETAS Registration Number:

## 7th SERVICE

Date of Service:.....

Next Service Due:.....

Details of Service work completed:

Signed:

Dealer's Stamp/HETAS Registration Number:

## 8th SERVICE

Date of Service:.....

Next Service Due:.....

Details of Service work completed:

Signed:

Dealer's Stamp/HETAS Registration Number:

## 9th SERVICE

Date of Service:.....

Next Service Due:.....

Details of Service work completed:

Signed:

Dealer's Stamp/HETAS Registration Number:

## 10th SERVICE

Date of Service:.....

Next Service Due:.....

Details of Service work completed:

Signed:

Dealer's Stamp/HETAS Registration Number:



# Warranty

When purchased new from an Authorised Ekol Retailer your new ApplePie stove includes an Extended 10 year limited warranty on the main body of the stove.

Details of Authorised Retailers can be found at [www.defrastoves.com](http://www.defrastoves.com) or [www.applepiestove.com](http://www.applepiestove.com)

Your warranty needs to be registered within 30 days of purchase and will be effective from date of purchase.

Your stove can be registered online:  
<http://www.defrastoves.com>

Appliances purchased outside of the Authorised Ekol Retailer network will carry the standard 12 month warranty.

If you do not register in time, or have not purchased through an Authorised Retailer don't worry - our stoves are built to last and you are unlikely to have any issues. In the unlikely event you do encounter any problems, we will still be here to help.

The Extended Warranty is valid for the first owner at the first fitted domestic location only. Installations into commercial premises, rental accommodation or where the primary user of the appliance will change on a regular basis will be covered by a limited 12 month warranty only.

To qualify, the appliance has to be installed to the relevant Building Regulations standards by a suitably trained competent person (such as a HETAS installer in the UK). Certificate of installation and the commissioning report along with proof of purchase will be required to register the warranty.

Any use of the appliance contrary to any instructions in this manual will invalidate the warranty.

The Warranty guarantees the main stove body be free of manufacturing defects for the relevant period.

**Excluded** from any warranty are:

1) Paint finish discolouration can occur normally and is not considered a fault. Paint which has failed to cure properly due to initial over or under firing is excluded from warranty.

2) Consumable items including but not limited to internal firebricks, glass, baffle plates, log retaining bars, paint and surface finishes, door and glass rope seals.

3) Damage caused by incorrect use, incorrect/ non-recommended fuel, over-firing or poor maintenance will not be covered and will invalidate the warranty.

4) Damage caused by unauthorised modifications or repair.

5) Faults or defects caused by local specific conditions such as draught problems or chimney defects.

6) Damage caused by corrosion due to the appliance being stored in unheated damp environments or by excessive moisture ingress via flue system.

7) Bioethanol burner units where fitted, are excluded from the Extended Warranty.

8) Warranty claims are limited to the repair or supply of replacement parts or entire appliance where necessary (to be determined by Ekol) including shipping costs (UK mainland only), and fitment of the replaced or repaired part if required, at the Ekol factory. This is not an 'on-site' warranty and any installation or removal costs or incidental costs will neither be covered nor accepted.

In the event of a successful warranty claim Ekol reserve the right to either (at their discretion) replace, repair or refund the purchase price of the goods in question.

Replaced or repaired parts are covered for the remainder of the Warranty period.

Should you encounter any problems with your system and if there is any doubt as to the cause of the issue, first contact your installer.

If the appliance is suspected to be at fault, contact your Ekol Retailer from whom you purchased the appliance - They will be able to help you quickly or contact us at Ekol on your behalf. You will need to provide a copy of your original sales receipt, installation certificate (i.e. from HETAS)/ or Building Control Certificate, and Service Record (see previous pages of this manual).

# Apple-Core General Dimensions

- Pedestal of Apple-Stack adds 209mm to the overall height
- Top oven of Baked-Apple adds 171mm to the overall height

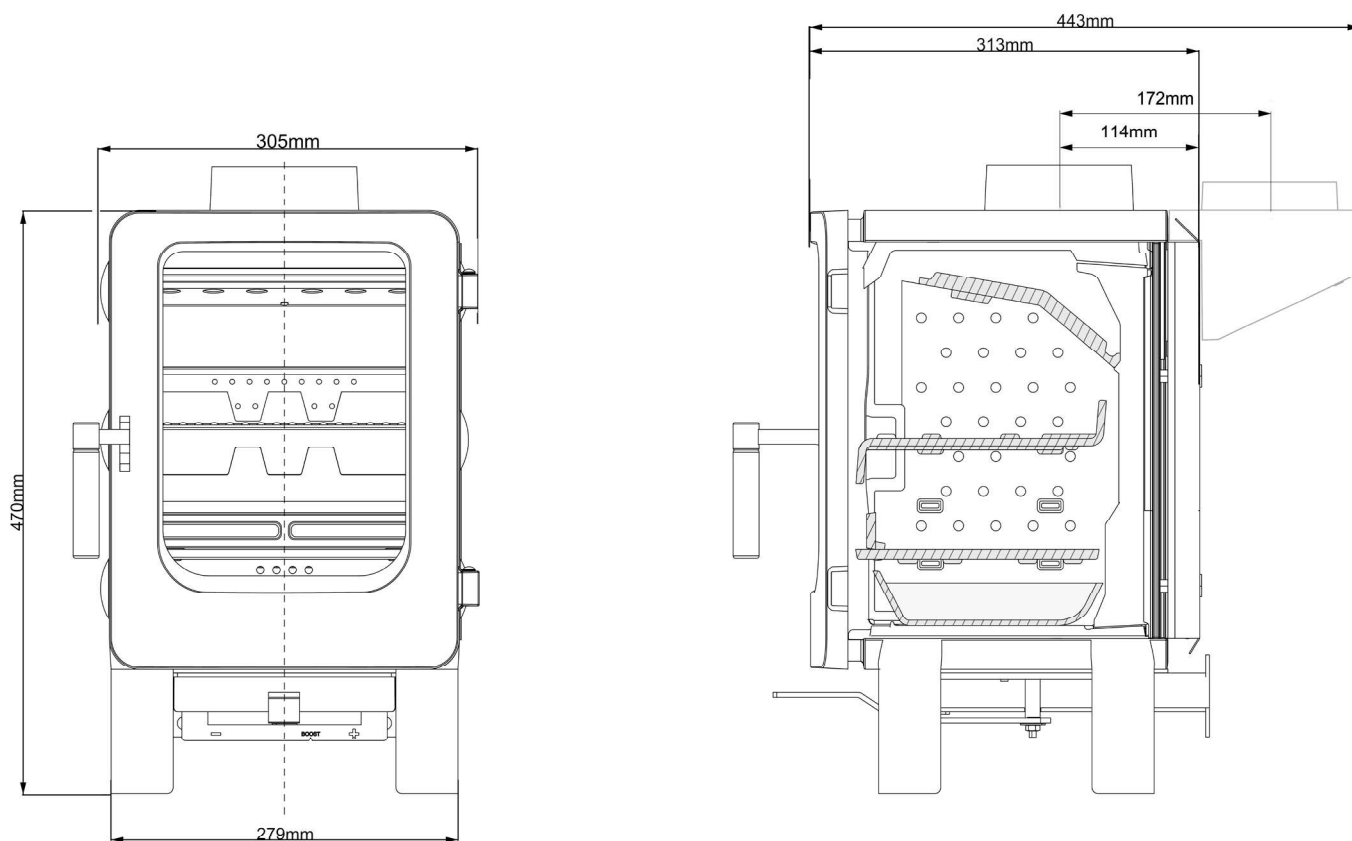

Ekol Stoves, (Part of the Saltfire Stoves Group) Station Works, Johns Road, Wareham,  
Dorset, UK, BH20 4BG  
[enquiries@defrastoves.com](mailto:enquiries@defrastoves.com) +44 (0)1929 555211

