

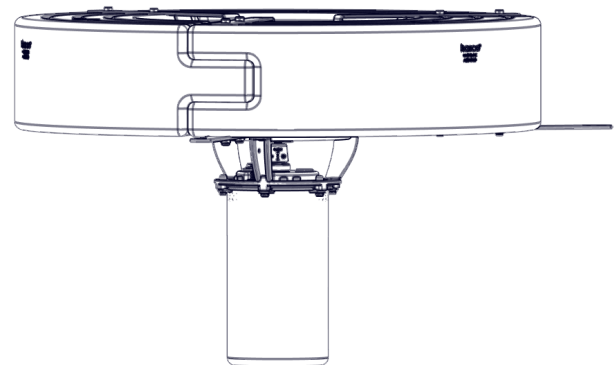

# 5.3AF SURFACE AERATOR

## OVERVIEW

- Complete package includes assembled motor unit, float, three mooring lines, and power cable.
- Operates in 26" (66cm) of water.
- Total package Listed by ETL to UL/CSA standards
- Corrosion protection for saltwater applications
- Intake near surface allows for shallow operation
- Optional lighting



## MOTOR UNIT

- 5HP, 208-240V, three phase
- 1750 RPM
- Oil cooled, continuous duty rated
- 17mm top and 20mm bottom bearings
- Thermal overload protection
- Dual, fully unitized heavy-duty carbon ceramic mechanical seal
- Series 300 Austenitic stainless steel can
- Cast stainless steel motor top
- Sacrificial anode
- Custom-engineered UV-resistant thermoplastic 2-blade weedless propeller

## POWER CABLE

- UL, CSA & NEC approved underwater rated cable
- SOOW Rated Power Cable
- 4 wire (L1, L2, G, N)
- Quick Disconnect
- Stainless steel strain relief
- 6' flex sleeving protection

## FLOAT

- UV-resistant high-density thermoplastic
- Three-piece lap joint
- Series 300 coated stainless steel hardware
- Three 50' braided nylon mooring ropes
- Optional coated stainless steel bottom screen

## CA-3235 CONTROL PANEL (OPTIONAL WITH U MODELS)

- UL type 3R/4X thermoplastic enclosure
- UL 508 Listed
- GFCI protection with 5ma trip level
- Surge protector
- Motor starter with adjustable overload
- Hand-Off-Auto switch
- 24-hour mechanical aerator timer
- Terminal block wiring
- 5-wire power required (L1, L2, L3, N, G)
- Use CF-3235 if purchasing optional lighting

# 5.3AF SURFACE AERATOR

HP	Voltage / Phase / Hz	Running Amps	Locked Rotor Amps	Suggested Pond Size (SA)*	Min. Depth of Operation (in.)
5	208-240V / 3 / 60	13	97	Up to 5	26"

\*Surface Acreage; also consider pond shape, depth, and oxygen demand.

## MODEL SPECIFICATIONS

Model	Cord Length	Cord Gauge	Number of Boxes*	Shipping Weight*
5.3AF100	100 ft.	14/4	4	163 lbs.
5.3AF150	150 ft.	12/4	4	173 lbs.
5.3AF200	200 ft.	10/4	4	184 lbs.
5.3AF250	250 ft.	10/4	4**	217 lbs.
5.3AF300	300 ft.	8/4	4**	269 lbs.
5.3AF400	400 ft.	8/4	4**	286 lbs.
5.3AF500	500 ft.	6/4	4**	323 lbs.

\* Subtract 1 box and 19 lbs. for U models.

\*\* Ships motor freight only.

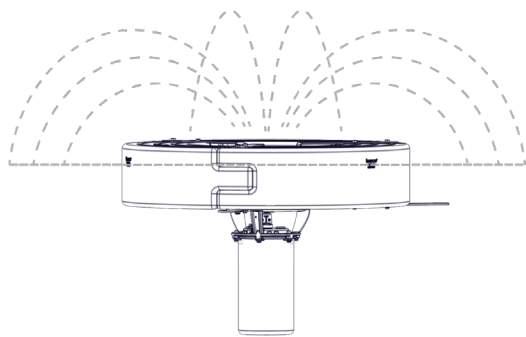

Pattern = 60" H x 148" W

