

# **DIECI**

## **2018 Equipment catalog**





# Table of Contents

<b>1</b>	<b>Symbols key.....</b>	<b>5</b>
<b>2</b>	<b>Tools.....</b>	<b>6</b>
2.1	Bucket.....	6
2.1.1	Bucket for light materials.....	6
2.1.2	Excavating bucket with teeth.....	10
2.1.3	Excavating bucket without teeth.....	12
2.2	Special items.....	16
2.2.1	Material basket.....	16
2.3	Counterplates.....	18
2.3.1	Counterplate.....	18
2.3.2	Counterplate with FEM forks.....	20
2.3.3	Counterplate with floating forks.....	22
2.4	Forks.....	24
2.4.1	Floating forks.....	24
2.4.2	Fork with two prongs.....	28
2.4.3	Fork with three prongs.....	30
<b>3</b>	<b>Equipment.....</b>	<b>32</b>
3.1	Fork positioner.....	32
3.1.1	Fork spreader.....	32
3.1.2	Forks spreader shifter.....	34
3.1.3	Forks shifting unit.....	36
3.2	Bucket.....	38
3.2.1	4 in 1 bucket.....	38
3.2.2	Bucket for silage with grab.....	42
3.2.3	Bucket for manure and generic material with grab.....	44
3.2.4	Bucket for fodder with grab.....	48
3.2.5	Mixing bucket.....	50
3.2.6	Ladle.....	52
3.3	Forks.....	54
3.3.1	Fork for logs.....	54
3.3.2	Multipurpose fork with holder.....	56
3.4	Blades.....	58
3.4.1	Angledozer blade.....	58
3.4.2	Snow plough.....	60
3.4.3	Tiltadozer blade.....	62
3.5	Grippers.....	64
3.5.1	Clamp for big wrapped bales.....	64
3.5.2	Gripper for cylinders.....	66
3.5.3	Grab clamp for two roll bales.....	68
3.5.4	Gripper for tires.....	70
3.5.5	Orange-peel grabber.....	72
3.5.6	Centring handler.....	74
3.5.7	Gripper for pipe.....	76
3.6	Special items.....	78
3.6.1	Angled sweeper.....	78
3.6.2	Sweeper box with collection.....	80
3.6.3	Front shredder.....	82
3.6.4	Two-stage turbine snow blower.....	84
<b>4</b>	<b>Lifting equipment.....</b>	<b>86</b>
4.1	Winches.....	86

## Table of Contents

---

4.1.1	Winch for forks holding plate .....	86
4.1.2	Crane extension with winch.....	88
4.2	Hooks .....	90
4.2.1	Hook for forks holding plate.....	90
4.2.2	Crane extension with hook.....	92
4.2.3	Jib with hook.....	94
<b>5</b>	<b>Baskets.....</b>	<b>96</b>
5.1	Front baskets.....	96
5.1.1	Front Basket .....	96
5.1.2	Extensible Front basket.....	98
5.2	Trilateral baskets.....	100
5.2.1	Trilateral Basket .....	100
5.2.2	Extensible Trilateral basket .....	102
5.2.3	Trilateral basket for tunnels.....	106
5.2.4	Volvo type basket.....	108
5.3	Positive / Negative jib .....	110
5.3.1	Positive / Negative jib .....	110
5.4	Baskets with lifting equipment.....	112
5.4.1	Extensible Trilateral basket with winch.....	112
5.5	Baskets for landing at high altitude .....	114
5.5.1	Extensible Trilateral basket with front opening.....	114
<b>6</b>	<b>Accessories .....</b>	<b>116</b>
6.1	Bucket.....	116
6.1.1	Level indicator.....	116
6.1.2	Blade protector and/or teeth cover.....	118
6.1.3	Full rear guard.....	120
6.1.4	Split rear guard.....	122
	<b>Detailed table of contents .....</b>	<b>124</b>



## Symbols key



Width



Height



Length



Equipment weight



Equipment capacity



Maximum walking surface width



Walking surface width



Walking surface length



Number of persons transported



Extension type



Forks cross section, width



Forks cross section, height



Forks length from tip to heel



Center of gravity of the load



Rope pull type



SAE heap capacity



Capacity (level)



Load maximum density



Number of teeth



Load yield

## Tools

### Bucket

#### Bucket for light materials

Indispensable tool for loading and handling material with a low specific weight, such as cereals, compost and shavings of various kinds.

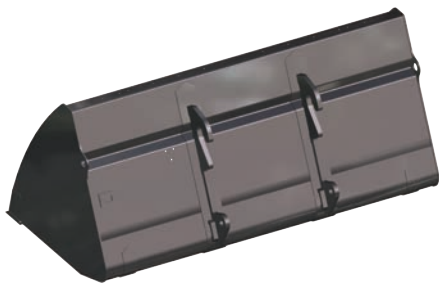

#### Optionals:

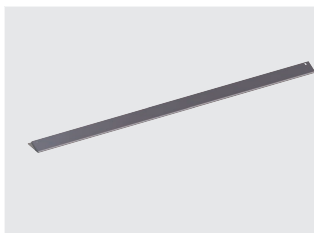

Blade cover

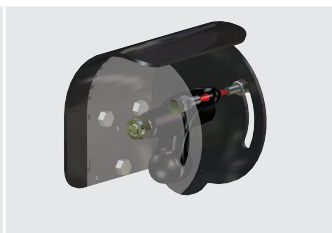





Mobile level indicator

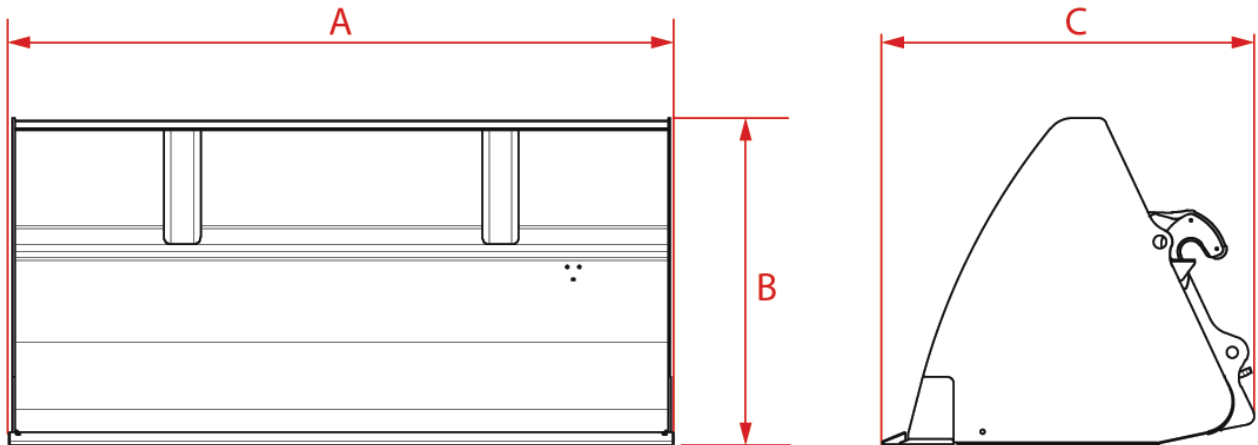

Full rear guard

**Technical Data**



	Code	A	B	C			
BUB2656	TBN0198	2450 mm (96,5 in)	1200 mm (47,2 in)	1308 mm (51,5 in)	2,5 m <sup>3</sup> (88 ft <sup>3</sup> )	800 kg/m <sup>3</sup> (50 lb/ft <sup>3</sup> )	680 kg (1499 lb)
BUB2656-S	TBN0202	2450 mm (96,5 in)	1200 mm (47,2 in)	1308 mm (51,5 in)	2,5 m <sup>3</sup> (88 ft <sup>3</sup> )	800 kg/m <sup>3</sup> (50 lb/ft <sup>3</sup> )	748,5 kg (1650 lb)
BUB2657	TBN0207	2450 mm (96,5 in)	1300 mm (51,2 in)	1680 mm (66,1 in)	3,5 m <sup>3</sup> (124 ft <sup>3</sup> )	500 kg/m <sup>3</sup> (31 lb/ft <sup>3</sup> )	796 kg (1755 lb)
BUB2657-S	TBN0212	2450 mm (96,5 in)	1300 mm (51,2 in)	1680 mm (66,1 in)	3,5 m <sup>3</sup> (124 ft <sup>3</sup> )	500 kg/m <sup>3</sup> (31 lb/ft <sup>3</sup> )	864,5 kg (1906 lb)
BUB2664	TBN0124	1980 mm (78 in)	925 mm (36,4 in)	1120 mm (44,1 in)	1,25 m <sup>3</sup> (44 ft <sup>3</sup> )	800 kg/m <sup>3</sup> (50 lb/ft <sup>3</sup> )	332 kg (732 lb)
BUB2664-S	TBN0114	1980 mm (78 in)	925 mm (36,4 in)	1120 mm (44,1 in)	1,25 m <sup>3</sup> (44 ft <sup>3</sup> )	800 kg/m <sup>3</sup> (50 lb/ft <sup>3</sup> )	365,5 kg (806 lb)
BUB2665	TBN0127	1980 mm (78 in)	1000 mm (39,4 in)	1245 mm (49 in)	1,5 m <sup>3</sup> (53 ft <sup>3</sup> )	500 kg/m <sup>3</sup> (31 lb/ft <sup>3</sup> )	367 kg (809 lb)
BUB2665-S	TBN0128	1980 mm (78 in)	1000 mm (39,4 in)	1245 mm (49 in)	1,5 m <sup>3</sup> (53 ft <sup>3</sup> )	500 kg/m <sup>3</sup> (31 lb/ft <sup>3</sup> )	401 kg (884 lb)
BUB2678	TBN0195	2400 mm (94,5 in)	950 mm (37,4 in)	1087 mm (42,8 in)	1,5 m <sup>3</sup> (53 ft <sup>3</sup> )	800 kg/m <sup>3</sup> (50 lb/ft <sup>3</sup> )	535 kg (1179 lb)
BUB2678-S	TBN0199	2400 mm (94,5 in)	950 mm (37,4 in)	1087 mm (42,8 in)	1,5 m <sup>3</sup> (53 ft <sup>3</sup> )	800 kg/m <sup>3</sup> (50 lb/ft <sup>3</sup> )	602 kg (1327 lb)
BUB2679	TBN0203	2400 mm (94,5 in)	1150 mm (45,3 in)	1387 mm (54,6 in)	2,5 m <sup>3</sup> (88 ft <sup>3</sup> )	500 kg/m <sup>3</sup> (31 lb/ft <sup>3</sup> )	673 kg (1484 lb)
BUB2679-S	TBN0208	2400 mm (94,5 in)	1150 mm (45,3 in)	1387 mm (54,6 in)	2,5 m <sup>3</sup> (88 ft <sup>3</sup> )	500 kg/m <sup>3</sup> (31 lb/ft <sup>3</sup> )	740 kg (1631 lb)

BUB2684	TBN0204	2400 mm (94,5 in)	1150 mm (45,3 in)	1365 mm (53,7 in)	2,5 m <sup>3</sup> (88 ft <sup>3</sup> )	500 kg/m <sup>3</sup> (31 lb/ft <sup>3</sup> )	674 kg (1486 lb)
BUB2684-S	TBN0209	2400 mm (94,5 in)	1150 mm (45,3 in)	1365 mm (53,7 in)	2,5 m <sup>3</sup> (88 ft <sup>3</sup> )	500 kg/m <sup>3</sup> (31 lb/ft <sup>3</sup> )	741 kg (1634 lb)
BUB2692	TBN0196	2400 mm (94,5 in)	950 mm (37,4 in)	1065 mm (41,9 in)	1,5 m <sup>3</sup> (53 ft <sup>3</sup> )	800 kg/m <sup>3</sup> (50 lb/ft <sup>3</sup> )	536,5 kg (1183 lb)
BUB2692-S	TBN0200	2400 mm (94,5 in)	950 mm (37,4 in)	1065 mm (41,9 in)	1,5 m <sup>3</sup> (53 ft <sup>3</sup> )	800 kg/m <sup>3</sup> (50 lb/ft <sup>3</sup> )	603 kg (1329 lb)
BUB2701	TBN0165	2100 mm (82,7 in)	925 mm (36,4 in)	1084 mm (42,7 in)	1,35 m <sup>3</sup> (48 ft <sup>3</sup> )	800 kg/m <sup>3</sup> (50 lb/ft <sup>3</sup> )	354,5 kg (782 lb)
BUB2701-S	TBN0167	2100 mm (82,7 in)	925 mm (36,4 in)	1084 mm (42,7 in)	1,35 m <sup>3</sup> (48 ft <sup>3</sup> )	800 kg/m <sup>3</sup> (50 lb/ft <sup>3</sup> )	390 kg (860 lb)
BUB2706	TBN0169	2100 mm (82,7 in)	1000 mm (39,4 in)	1209 mm (47,6 in)	1,65 m <sup>3</sup> (58 ft <sup>3</sup> )	500 kg/m <sup>3</sup> (31 lb/ft <sup>3</sup> )	390 kg (860 lb)
BUB2706-S	TBN0171	2100 mm (82,7 in)	1000 mm (39,4 in)	1209 mm (47,6 in)	1,65 m <sup>3</sup> (58 ft <sup>3</sup> )	500 kg/m <sup>3</sup> (31 lb/ft <sup>3</sup> )	425,5 kg (938 lb)
BUB2713	TBN0166	1980 mm (78 in)	925 mm (36,4 in)	1170 mm (46,1 in)	1,25 m <sup>3</sup> (44 ft <sup>3</sup> )	800 kg/m <sup>3</sup> (50 lb/ft <sup>3</sup> )	342 kg (754 lb)
BUB2713-S	TBN0168	1980 mm (78 in)	925 mm (36,4 in)	1170 mm (46,1 in)	1,25 m <sup>3</sup> (44 ft <sup>3</sup> )	800 kg/m <sup>3</sup> (50 lb/ft <sup>3</sup> )	375,5 kg (828 lb)
BUB2714	TBN0170	1980 mm (78 in)	1000 mm (39,4 in)	1295 mm (51 in)	1,5 m <sup>3</sup> (53 ft <sup>3</sup> )	500 kg/m <sup>3</sup> (31 lb/ft <sup>3</sup> )	377 kg (831 lb)
BUB2714-S	TBN0172	1980 mm (78 in)	1000 mm (39,4 in)	1295 mm (51 in)	1,5 m <sup>3</sup> (53 ft <sup>3</sup> )	500 kg/m <sup>3</sup> (31 lb/ft <sup>3</sup> )	410,5 kg (905 lb)
BUB2719	TBN0106	2400 mm (94,5 in)	950 mm (37,4 in)	1087 mm (42,8 in)	1,5 m <sup>3</sup> (53 ft <sup>3</sup> )	800 kg/m <sup>3</sup> (50 lb/ft <sup>3</sup> )	535 kg (1179 lb)
BUB2719-S	TBN0107	2400 mm (94,5 in)	950 mm (37,4 in)	1087 mm (42,8 in)	1,5 m <sup>3</sup> (53 ft <sup>3</sup> )	800 kg/m <sup>3</sup> (50 lb/ft <sup>3</sup> )	602 kg (1327 lb)
BUB2720	TBN0108	2400 mm (94,5 in)	1150 mm (45,3 in)	1387 mm (54,6 in)	2,5 m <sup>3</sup> (88 ft <sup>3</sup> )	500 kg/m <sup>3</sup> (31 lb/ft <sup>3</sup> )	673 kg (1484 lb)
BUB2720-S	TBN0109	2400 mm (94,5 in)	1150 mm (45,3 in)	1387 mm (54,6 in)	2,5 m <sup>3</sup> (88 ft <sup>3</sup> )	500 kg/m <sup>3</sup> (31 lb/ft <sup>3</sup> )	740 kg (1631 lb)
BUB2751	TBN0197	2450 mm (96,5 in)	1050 mm (41,3 in)	1237 mm (48,7 in)	2,0 m <sup>3</sup> (71 ft <sup>3</sup> )	800 kg/m <sup>3</sup> (50 lb/ft <sup>3</sup> )	600 kg (1323 lb)
BUB2751-S	TBN0201	2450 mm (96,5 in)	1050 mm (41,3 in)	1237 mm (48,7 in)	2,0 m <sup>3</sup> (71 ft <sup>3</sup> )	800 kg/m <sup>3</sup> (50 lb/ft <sup>3</sup> )	680 kg (1499 lb)
BUB2753	TBN0205	2450 mm (96,5 in)	1225 mm (48,2 in)	1498 mm (59 in)	3,0 m <sup>3</sup> (106 ft <sup>3</sup> )	500 kg/m <sup>3</sup> (31 lb/ft <sup>3</sup> )	732 kg (1614 lb)
BUB2753-S	TBN0210	2450 mm (96,5 in)	1225 mm (48,2 in)	1498 mm (59 in)	3,0 m <sup>3</sup> (106 ft <sup>3</sup> )	500 kg/m <sup>3</sup> (31 lb/ft <sup>3</sup> )	815 kg (1797 lb)
BUB2754	TBN0206	2450 mm (96,5 in)	1225 mm (48,2 in)	1498 mm (59 in)	3,0 m <sup>3</sup> (106 ft <sup>3</sup> )	500 kg/m <sup>3</sup> (31 lb/ft <sup>3</sup> )	732 kg (1614 lb)
BUB2754-S	TBN0211	2450 mm (96,5 in)	1225 mm (48,2 in)	1498 mm (59 in)	3,0 m <sup>3</sup> (106 ft <sup>3</sup> )	500 kg/m <sup>3</sup> (31 lb/ft <sup>3</sup> )	815 kg (1797 lb)



## Excavating bucket with teeth

The excavating bucket with teeth has been designed for excavating and loading high density soils, such as earth, sand gravel and compact clay.

The teeth are interchangeable and provide excellent penetration, essential for working with high density material.





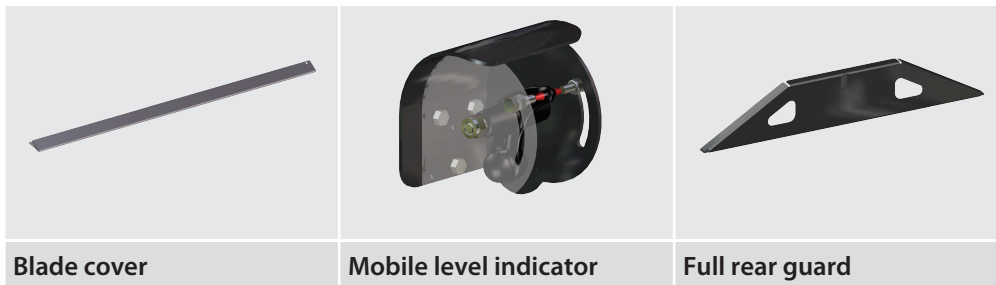

### Optionals:

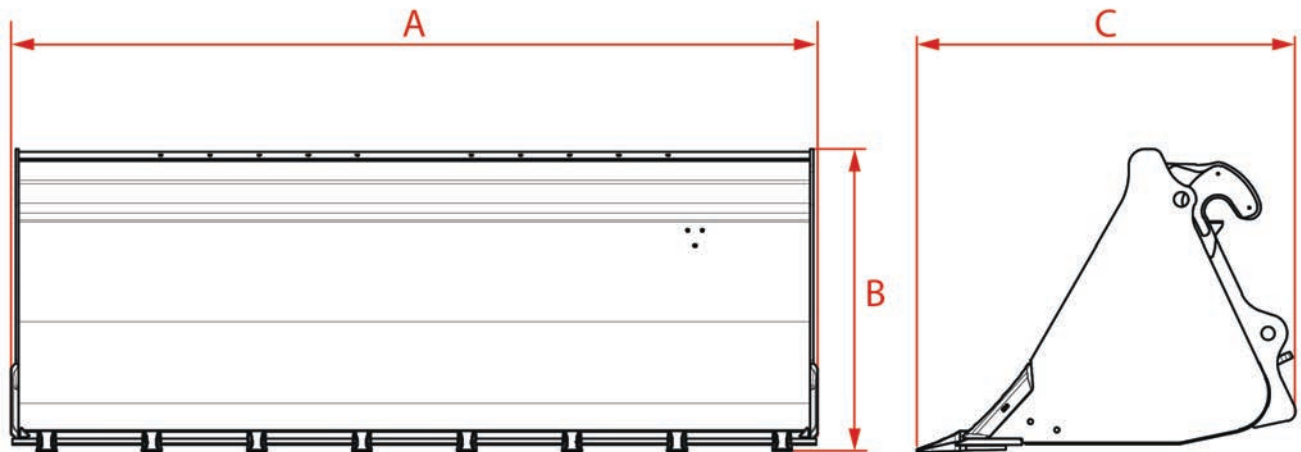

**Technical Data**



	Code	A	B	C				
BUB2655	TBN0194	2450 mm (96,5 in)	900 mm (35,4 in)	1033 mm (40,7 in)	1,25 m <sup>3</sup> (44 ft <sup>3</sup> )	1800 kg/m <sup>3</sup> (112 lb/ft <sup>3</sup> )	8	580 kg (1279 lb)
BUB2662	TBN0117	1980 mm (78 in)	850 mm (33,5 in)	945 mm (37,2 in)	0,85 m <sup>3</sup> (30 ft <sup>3</sup> )	1800 kg/m <sup>3</sup> (112 lb/ft <sup>3</sup> )	6	297 kg (655 lb)
BUB2676	TBN0191	2400 mm (94,5 in)	893 mm (35,2 in)	987 mm (38,9 in)	1,0 m <sup>3</sup> (35 ft <sup>3</sup> )	1800 kg/m <sup>3</sup> (112 lb/ft <sup>3</sup> )	8	512,5 kg (1130 lb)
BUB2680	TBN0102	2300 mm (90,6 in)	893 mm (35,2 in)	965 mm (38 in)	1,2 m <sup>3</sup> (42 ft <sup>3</sup> )	1800 kg/m <sup>3</sup> (112 lb/ft <sup>3</sup> )	7	488,2 kg (1076 lb)
BUB2691	TBN0192	2100 mm (82,7 in)	893 mm (35,2 in)	965 mm (38 in)	1,1 m <sup>3</sup> (39 ft <sup>3</sup> )	1800 kg/m <sup>3</sup> (112 lb/ft <sup>3</sup> )	7	467,5 kg (1031 lb)
BUB2696	TBN0193	2400 mm (94,5 in)	893 mm (35,2 in)	965 mm (38 in)	1,25 m <sup>3</sup> (44 ft <sup>3</sup> )	1800 kg/m <sup>3</sup> (112 lb/ft <sup>3</sup> )	8	506,7 kg (1117 lb)
BUB2698	TBN0121	1900 mm (74,8 in)	850 mm (33,5 in)	945 mm (37,2 in)	0,8 m <sup>3</sup> (28 ft <sup>3</sup> )	1800 kg/m <sup>3</sup> (112 lb/ft <sup>3</sup> )	6	289 kg (637 lb)
BUB2700	TBN0162	2100 mm (82,7 in)	850 mm (33,5 in)	909 mm (35,8 in)	0,9 m <sup>3</sup> (32 ft <sup>3</sup> )	1800 kg/m <sup>3</sup> (112 lb/ft <sup>3</sup> )	6	318 kg (701 lb)
BUB2712	TBN0161	1900 mm (74,8 in)	850 mm (33,5 in)	995 mm (39,2 in)	0,8 m <sup>3</sup> (28 ft <sup>3</sup> )	1800 kg/m <sup>3</sup> (112 lb/ft <sup>3</sup> )	6	298,8 kg (659 lb)
BUB2716	TBN0163	2100 mm (82,7 in)	850 mm (33,5 in)	995 mm (39,2 in)	0,9 m <sup>3</sup> (32 ft <sup>3</sup> )	1800 kg/m <sup>3</sup> (112 lb/ft <sup>3</sup> )	6	318 kg (701 lb)
BUB2718	TBN0105	2400 mm (94,5 in)	893 mm (35,2 in)	987 mm (38,9 in)	1,0 m <sup>3</sup> (35 ft <sup>3</sup> )	1800 kg/m <sup>3</sup> (112 lb/ft <sup>3</sup> )	8	512,5 kg (1130 lb)
BUB2745	TBN0148	1980 mm (78 in)	850 mm (33,5 in)	945 mm (37,2 in)	0,85 m <sup>3</sup> (30 ft <sup>3</sup> )	1800 kg/m <sup>3</sup> (112 lb/ft <sup>3</sup> )	6	297 kg (655 lb)
BUB2750	TBN0164	1500 mm (59,1 in)	850 mm (33,5 in)	945 mm (37,2 in)	0,6 m <sup>3</sup> (21 ft <sup>3</sup> )	1800 kg/m <sup>3</sup> (112 lb/ft <sup>3</sup> )	6	247,5 kg (546 lb)

## Excavating bucket without teeth



The excavating bucket has been designed for excavating and loading high density soils, such as earth, sand gravel and compact clay.

The bucket shape provides excellent penetration, with consequent maximization of the load to move it in a stable way.

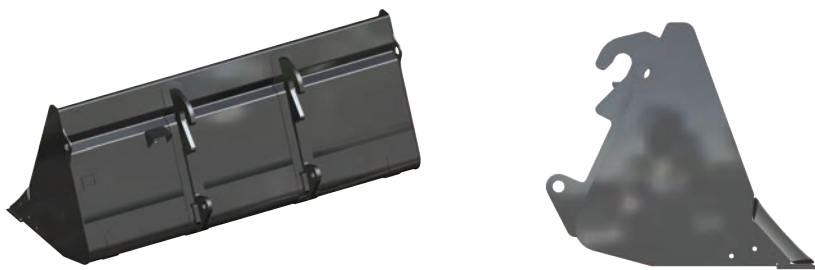



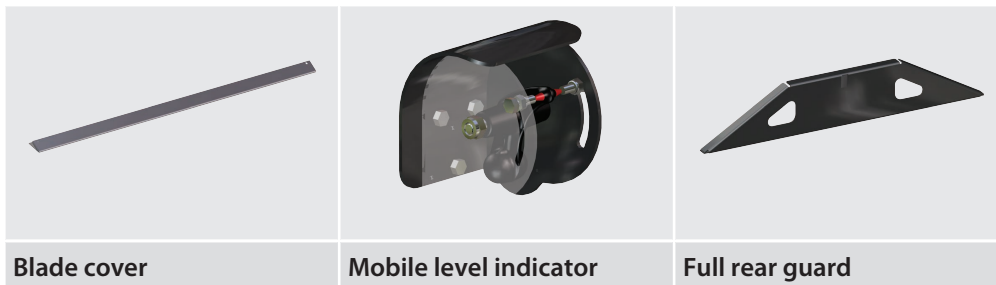

### Optionals:



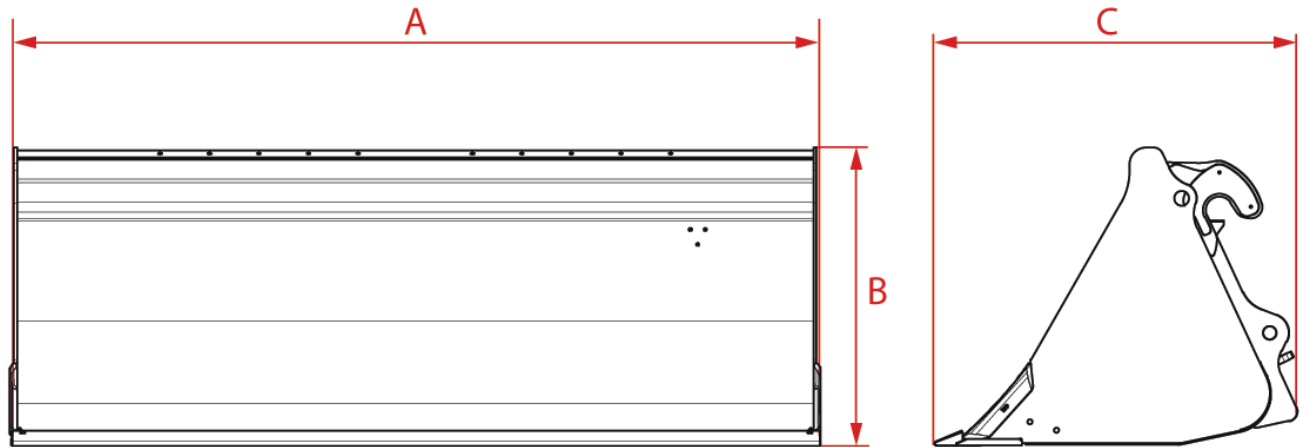

**Technical Data**



	Code	A	B	C			
BUB2654	TBN0185	2450 mm (96,5 in)	900 mm (35,4 in)	1033 mm (40,7 in)	1,25 m <sup>3</sup> (44 ft <sup>3</sup> )	1800 kg/m <sup>3</sup> (112 lb/ft <sup>3</sup> )	559 kg (1232 lb)
BUB2654-S	TBN0190	2450 mm (96,5 in)	900 mm (35,4 in)	1033 mm (40,7 in)	1,25 m <sup>3</sup> (44 ft <sup>3</sup> )	1800 kg/m <sup>3</sup> (112 lb/ft <sup>3</sup> )	627,5 kg (1383 lb)
BUB2661	TBN0115	1980 mm (78 in)	850 mm (33,5 in)	945 mm (37,2 in)	0,85 m <sup>3</sup> (30 ft <sup>3</sup> )	1800 kg/m <sup>3</sup> (112 lb/ft <sup>3</sup> )	286,5 kg (632 lb)
BUB2661-S	TBN0116	1980 mm (78 in)	850 mm (33,5 in)	945 mm (37,2 in)	0,85 m <sup>3</sup> (30 ft <sup>3</sup> )	1800 kg/m <sup>3</sup> (112 lb/ft <sup>3</sup> )	320 kg (705 lb)
BUB2677	TBN0181	2400 mm (94,5 in)	893 mm (35,2 in)	987 mm (38,9 in)	1,0 m <sup>3</sup> (35 ft <sup>3</sup> )	1800 kg/m <sup>3</sup> (112 lb/ft <sup>3</sup> )	490 kg (1080 lb)
BUB2677-S	TBN0186	2400 mm (94,5 in)	893 mm (35,2 in)	987 mm (38,9 in)	1,0 m <sup>3</sup> (35 ft <sup>3</sup> )	1800 kg/m <sup>3</sup> (112 lb/ft <sup>3</sup> )	557 kg (1228 lb)
BUB2690	TBN0182	2100 mm (82,7 in)	893 mm (35,2 in)	965 mm (38 in)	1,1 m <sup>3</sup> (39 ft <sup>3</sup> )	1800 kg/m <sup>3</sup> (112 lb/ft <sup>3</sup> )	445 kg (981 lb)
BUB2690-S	TBN0187	2100 mm (82,7 in)	893 mm (35,2 in)	965 mm (38 in)	1,1 m <sup>3</sup> (39 ft <sup>3</sup> )	1800 kg/m <sup>3</sup> (112 lb/ft <sup>3</sup> )	505 kg (1113 lb)
BUB2694	TBN0183	2300 mm (90,6 in)	893 mm (35,2 in)	965 mm (38 in)	1,2 m <sup>3</sup> (42 ft <sup>3</sup> )	1800 kg/m <sup>3</sup> (112 lb/ft <sup>3</sup> )	470 kg (1036 lb)
BUB2694-S	TBN0188	2300 mm (90,6 in)	893 mm (35,2 in)	965 mm (38 in)	1,2 m <sup>3</sup> (42 ft <sup>3</sup> )	1800 kg/m <sup>3</sup> (112 lb/ft <sup>3</sup> )	534 kg (1177 lb)
BUB2695	TBN0184	2400 mm (94,5 in)	893 mm (35,2 in)	965 mm (38 in)	1,25 m <sup>3</sup> (44 ft <sup>3</sup> )	1800 kg/m <sup>3</sup> (112 lb/ft <sup>3</sup> )	488,5 kg (1077 lb)
BUB2695-S	TBN0189	2400 mm (94,5 in)	893 mm (35,2 in)	965 mm (38 in)	1,25 m <sup>3</sup> (44 ft <sup>3</sup> )	1800 kg/m <sup>3</sup> (112 lb/ft <sup>3</sup> )	555,5 kg (1225 lb)

BUB2697	TBN0122	1900 mm (74,8 in)	850 mm (33,5 in)	945 mm (37,2 in)	0,8 m <sup>3</sup> (28 ft <sup>3</sup> )	1800 kg/m <sup>3</sup> (112 lb/ft <sup>3</sup> )	278,5 kg (614 lb)
BUB2697-S	TBN0123	1900 mm (74,8 in)	850 mm (33,5 in)	945 mm (37,2 in)	0,8 m <sup>3</sup> (28 ft <sup>3</sup> )	1800 kg/m <sup>3</sup> (112 lb/ft <sup>3</sup> )	310 kg (683 lb)
BUB2699	TBN0150	2100 mm (82,7 in)	850 mm (33,5 in)	909 mm (35,8 in)	0,9 m <sup>3</sup> (32 ft <sup>3</sup> )	1800 kg/m <sup>3</sup> (112 lb/ft <sup>3</sup> )	307 kg (677 lb)
BUB2699-S	TBN0151	2100 mm (82,7 in)	850 mm (33,5 in)	909 mm (35,8 in)	0,9 m <sup>3</sup> (32 ft <sup>3</sup> )	1800 kg/m <sup>3</sup> (112 lb/ft <sup>3</sup> )	342,5 kg (755 lb)
BUB2711	TBN0152	1900 mm (74,8 in)	850 mm (33,5 in)	995 mm (39,2 in)	0,8 m <sup>3</sup> (28 ft <sup>3</sup> )	1800 kg/m <sup>3</sup> (112 lb/ft <sup>3</sup> )	288 kg (635 lb)
BUB2711-S	TBN0153	1900 mm (74,8 in)	850 mm (33,5 in)	995 mm (39,2 in)	0,8 m <sup>3</sup> (28 ft <sup>3</sup> )	1800 kg/m <sup>3</sup> (112 lb/ft <sup>3</sup> )	320 kg (705 lb)
BUB2715	TBN0156	2100 mm (82,7 in)	850 mm (33,5 in)	995 mm (39,2 in)	0,9 m <sup>3</sup> (32 ft <sup>3</sup> )	1800 kg/m <sup>3</sup> (112 lb/ft <sup>3</sup> )	307 kg (677 lb)
BUB2715-S	TBN0157	2100 mm (82,7 in)	850 mm (33,5 in)	995 mm (39,2 in)	0,9 m <sup>3</sup> (32 ft <sup>3</sup> )	1800 kg/m <sup>3</sup> (112 lb/ft <sup>3</sup> )	342,5 kg (755 lb)
BUB2749	TBN0158	1500 mm (59,1 in)	850 mm (33,5 in)	945 mm (37,2 in)	0,6 m <sup>3</sup> (21 ft <sup>3</sup> )	1800 kg/m <sup>3</sup> (112 lb/ft <sup>3</sup> )	238,5 kg (526 lb)
BUB2749-S	TBN0159	1500 mm (59,1 in)	850 mm (33,5 in)	945 mm (37,2 in)	0,6 m <sup>3</sup> (21 ft <sup>3</sup> )	1800 kg/m <sup>3</sup> (112 lb/ft <sup>3</sup> )	263,5 kg (581 lb)



## Special items



### Material basket

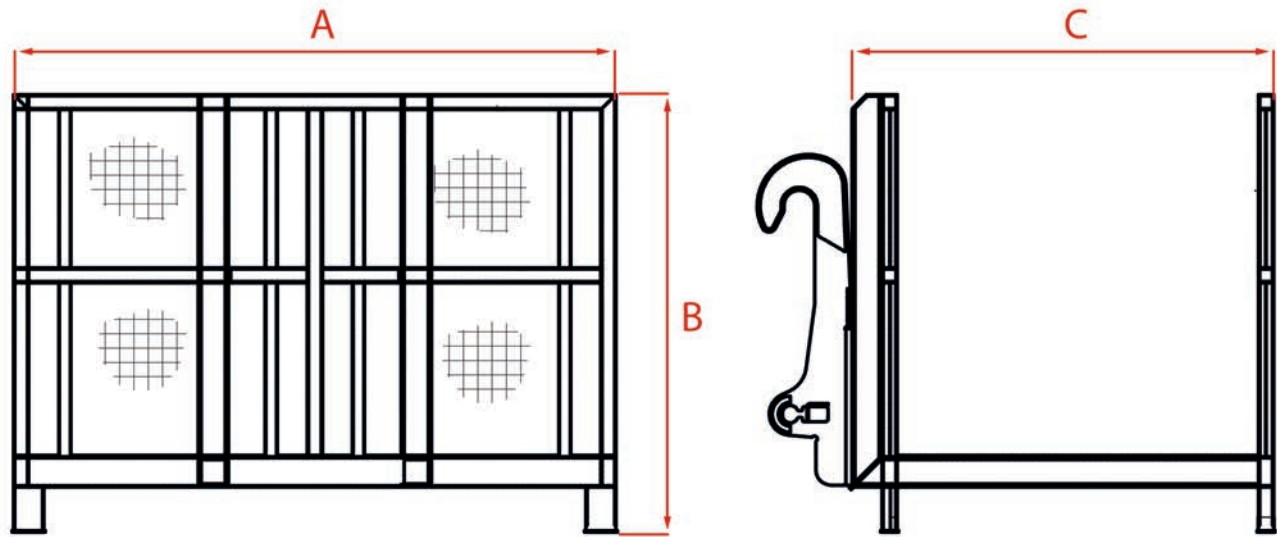

This equipment is used to transport inert material at height quickly and safely.

**Technical Data**



	Code	<b>A</b>	<b>B</b>	<b>C</b>		
BUD6217	TCS0016	2010 mm (79,1 in)	1450 mm (57,1 in)	1620 mm (63,8 in)	1000 kg (2205 lb)	685 kg (1510 lb)
BUD6218	TCS0002	2010 mm (79,1 in)	1450 mm (57,1 in)	1620 mm (63,8 in)	1000 kg (2205 lb)	755 kg (1664 lb)
BUD6280	TCS0045	2010 mm (79,1 in)	1450 mm (57,1 in)	1620 mm (63,8 in)	500 kg (1102 lb)	395 kg (871 lb)
BUD6352	TCS0067	2010 mm (79,1 in)	1450 mm (57,1 in)	1620 mm (63,8 in)	1500 kg (3307 lb)	535 kg (1179 lb)





## Counterplates

### Counterplate

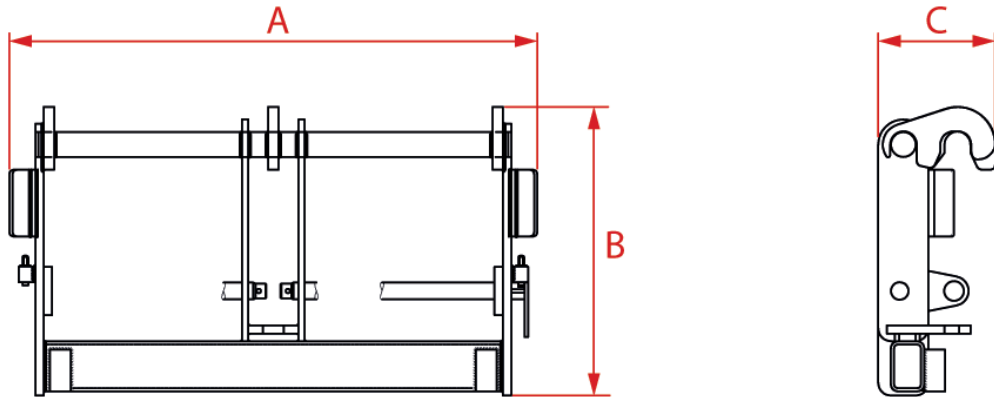

**Technical Data**



	Code				
BCV8238	TCV0002	1265 mm (49,8 in)	690 mm (27,2 in)	280 mm (11 in)	125 kg (276 lb)
BCV8279	TCV0007	1405 mm (55,3 in)	720 mm (28,3 in)	200 mm (7,9 in)	132 kg (291 lb)
BCV8276	TCV0011	1415 mm (55,7 in)	760 mm (29,9 in)	350 mm (13,8 in)	210 kg (463 lb)

## Counterplate with FEM forks



Counterplate with forks and FEM coupling, equipped with lower hooks and upper positioning fasteners to be adapted to the width of the load.



**Technical Data**

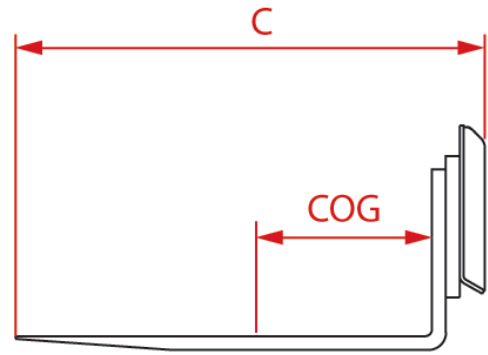
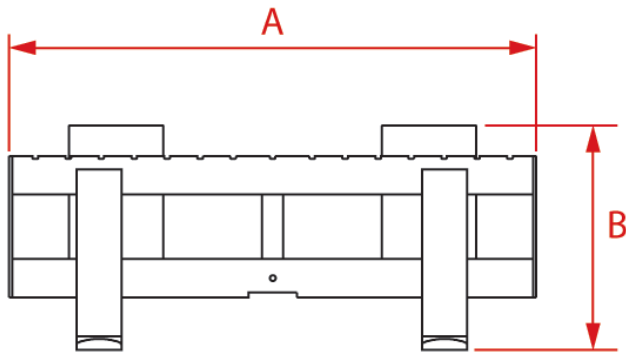

	Code	A	B	C			COG	
BCV8282	TCV0018	1520 mm (59,8 in)	650 mm (25,6 in)	1540 mm (60,6 in)	120 mm (4,7 in)	50 mm (2 in)	500 mm (19,7 in)	255 kg (562 lb)

## Counterplate with floating forks









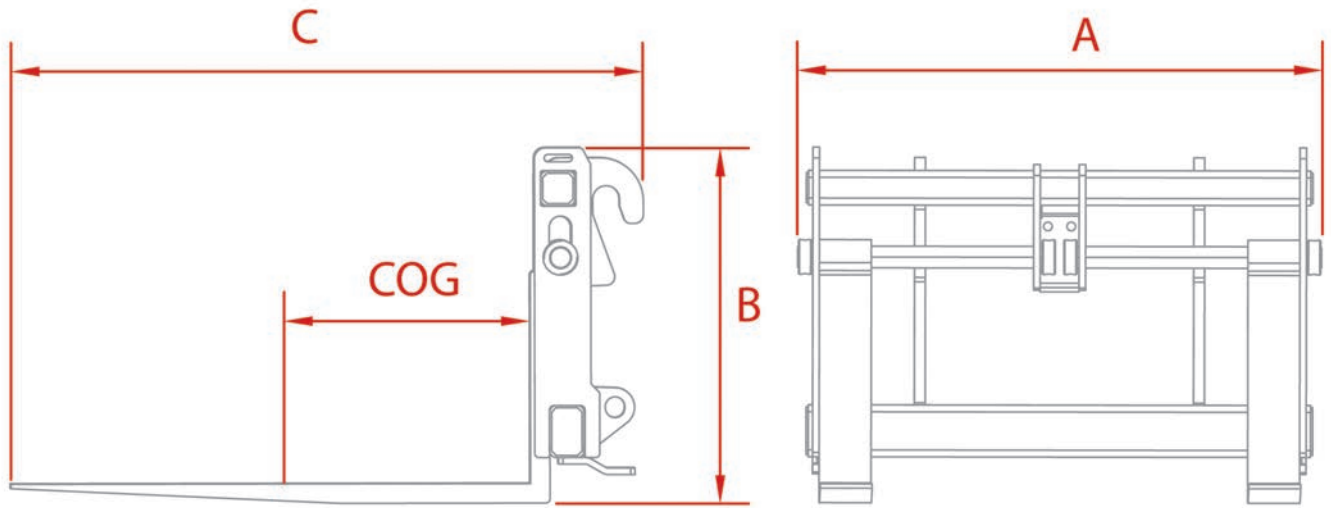

Counterplate with floating forks, which can self-adjust vertically to adapt to non-level operational load conditions.



**Technical Data**



	Code								
BCV8281	TCV0017	1216 mm (47,9 in)	820 mm (32,3 in)	1445 mm (56,9 in)	120 mm (4,7 in)	45 mm (1,8 in)	500 mm (19,7 in)	2600 kg (5732 lb)	263 kg (580 lb)

## Forks

### Floating forks



The floating forks are used for loading and unloading pallets even from inclined and uneven surfaces such as trucks with heavy gradients and rough terrain, they adapt perfectly to the support surface of the material to be moved thanks to their vertical sliding movement.



**Technical Data**

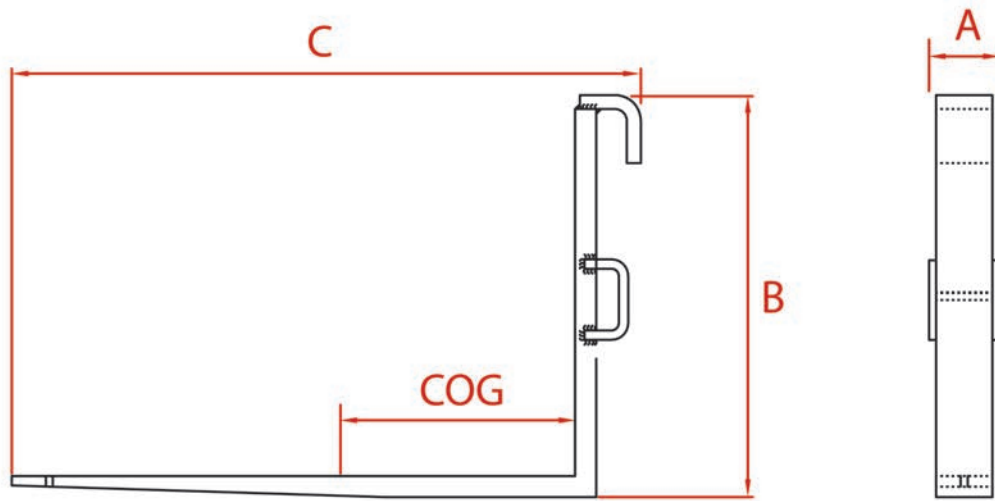

	Code	A	B	C				COG		
BUD1059	TFR0008	150 mm (5,9 in)	855 mm (33,7 in)	1340 mm (52,8 in)	120 mm (4,7 in)	45 mm (1,8 in)	1200 mm (47,2 in)	500 mm (19,7 in)	3800 kg (8378 lb)	85 kg (187 lb)
BUD1060	TFR0001	150 mm (5,9 in)	855 mm (33,7 in)	1340 mm (52,8 in)	120 mm (4,7 in)	45 mm (1,8 in)	1200 mm (47,2 in)	500 mm (19,7 in)	3800 kg (8378 lb)	82 kg (181 lb)
BUD1074	TFR0006	100 mm (3,9 in)	650 mm (25,6 in)	1100 mm (43,3 in)	100 mm (3,9 in)	50 mm (2 in)	1050 mm (41,3 in)	600 mm (23,6 in)	3900 KG (8598 lb)	110 KG (243 lb)
BUD1077	TFR0007	150 mm (5,9 in)	865 mm (34,1 in)	1345 mm (53 in)	120 mm (4,7 in)	50 mm (2 in)	1200 mm (47,2 in)	500 mm (19,7 in)	4500 kg (9921 lb)	97 kg (214 lb)
BUD1079	TFR0004	150 mm (5,9 in)	860 mm (33,9 in)	1345 mm (53 in)	120 mm (4,7 in)	50 mm (2 in)	1200 mm (47,2 in)	500 mm (19,7 in)	4000 kg (8818 lb)	85 kg (187 lb)
BUD1085	TFR0022	200 mm (7,9 in)	1100 mm (43,3 in)	2025 mm (79,7 in)	200 mm (7,9 in)	70 mm (2,8 in)	1800 mm (70,9 in)	600 mm (23,6 in)	12000 kg (26455 lb)	320 kg (705 lb)
BUD1091	TFR0023	200 mm (7,9 in)	1130 mm (44,5 in)	2645 mm (104,1 in)	200 mm (7,9 in)	80 mm (3,1 in)	2400 mm (94,5 in)	600 mm (23,6 in)	16000 kg (35274 lb)	444 kg (979 lb)
BUD1093	TFR0021	200 mm (7,9 in)	1100 mm (43,3 in)	1425 mm (56,1 in)	200 mm (7,9 in)	70 mm (2,8 in)	1200 mm (47,2 in)	600 mm (23,6 in)	12000 kg (26455 lb)	257 kg (567 lb)
BUD1104	TFR0024	200 mm (7,9 in)	1160 mm (45,7 in)	2059 mm (81,1 in)	200 mm (7,9 in)	95 mm (3,7 in)	1800 mm (70,9 in)	900 mm (35,4 in)	21000 kg (46297 lb)	440 kg (970 lb)
BUD1105	TFR0025	200 mm (7,9 in)	1160 mm (45,7 in)	2659 mm (104,7 in)	200 mm (7,9 in)	95 mm (3,7 in)	2400 mm (94,5 in)	900 mm (35,4 in)	21000 kg (46297 lb)	530 kg (1168 lb)

BUD1187	TFR0010	180 mm (7,1 in)	890 mm (35 in)	1375 mm (54,1 in)	150 mm (5,9 in)	60 mm (2,4 in)	1200 mm (47,2 in)	600 mm (23,6 in)	7500 kg (16535 lb)	140 kg (309 lb)
BUD1188	TFR0018	230 mm (9,1 in)	890 mm (35 in)	1575 mm (62 in)	200 mm (7,9 in)	60 mm (2,4 in)	1400 mm (55,1 in)	600 mm (23,6 in)	7500 kg (16535 lb)	220 kg (485 lb)
BUD1219	TFR0027	150 mm (5,9 in)	890 mm (35 in)	1355 mm (53,3 in)	120 mm (4,7 in)	45 mm (1,8 in)	1200 mm (47,2 in)	600 mm (23,6 in)	4500 kg (9921 lb)	410 kg (904 lb)





## Fork with two prongs



Tool suitable for handling round or square hay or fodder bales.

The front tips can be turned up for road circulation.





The frame is equipped with an upper (extensible) protection to prevent material from falling.



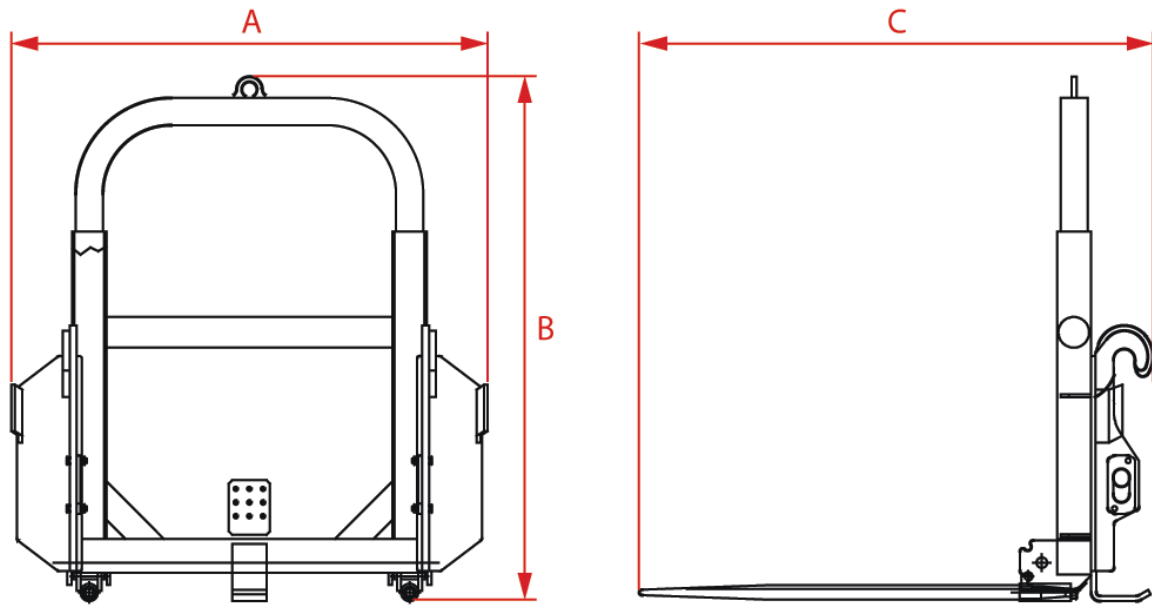

**Technical Data**



	Code					
BUB2615	TGN0007	1400 mm (55,1 in)	1500 mm (59,1 in)	1500 mm (59,1 in)	600 kg (1323 lb)	196 kg (432 lb)
BUB2623	TGN0036	1400 mm (55,1 in)	1500 mm (59,1 in)	1500 mm (59,1 in)	600 kg (1323 lb)	196 kg (432 lb)
BUB2643	TGN0018	1400 mm (55,1 in)	1500 mm (59,1 in)	1500 mm (59,1 in)	600 kg (1323 lb)	196 kg (432 lb)

## Fork with three prongs



Tool suitable for handling round or square hay or fodder bales.



The front tips can be turned up for road circulation.

The frame is equipped with an upper (extensible) protection to prevent material from falling.

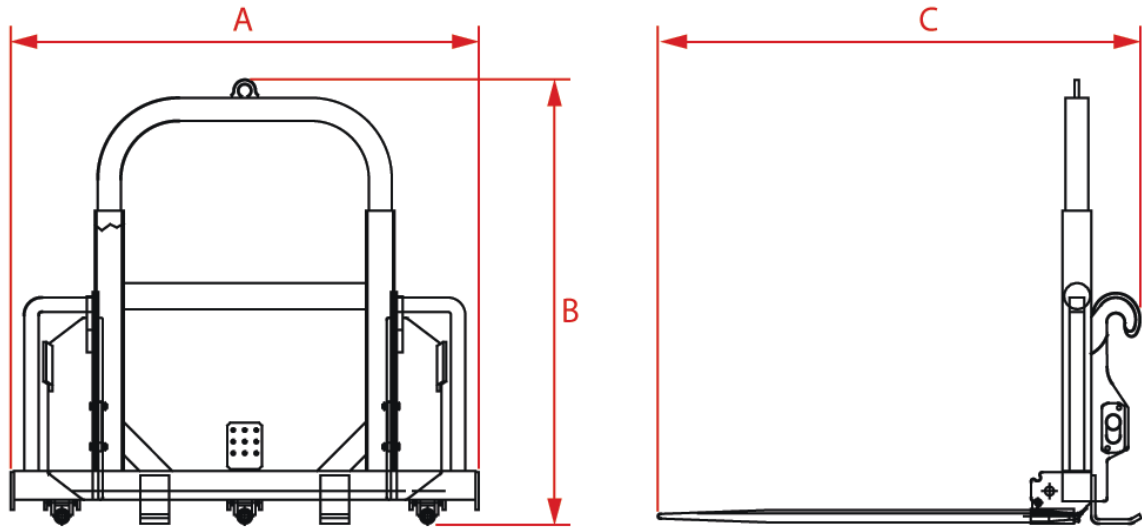

**Technical Data**



	Code	<b>A</b>	<b>B</b>	<b>C</b>		
BUB2611	TGN0063	1650 mm (65 in)	1500 mm (59,1 in)	1500 mm (59,1 in)	600 kg (1323 lb)	230 kg (507 lb)
BUB2616	TGN0008	1650 mm (65 in)	1500 mm (59,1 in)	1500 mm (59,1 in)	1200 kg (2646 lb)	230 kg (507 lb)
BUB2620	TGN0019	1650 mm (65 in)	1500 mm (59,1 in)	1500 mm (59,1 in)	600 kg (1323 lb)	230 kg (507 lb)

## Equipment

### Fork positioner







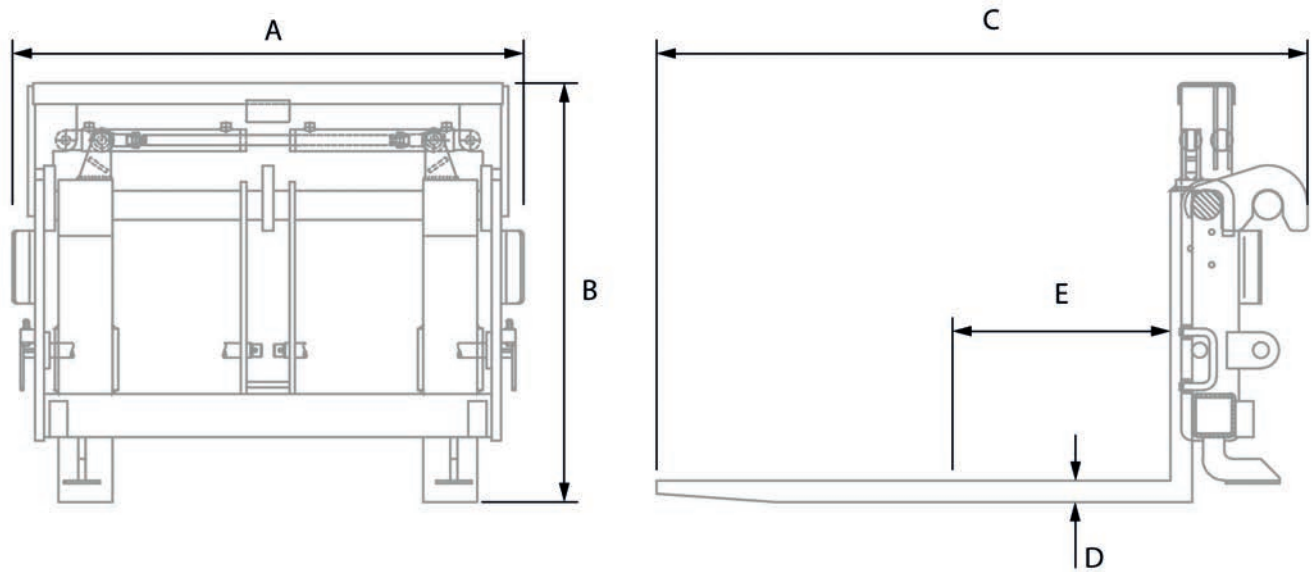

### Fork spreader



This equipment is used to widen or tighten the forks by means of a hydraulic control from the cab.

**Technical Data**



	Code								
BCV8063	TCV0001	1270 mm (50 in)	1123 mm (44,2 in)	1473 mm (58 in)	120 mm (4,7 in)	45 mm (1,8 in)	500 mm (19,7 in)	3800 kg (8378 lb)	390 kg (860 lb)
BCV8069	TCV0008	1410 mm (55,5 in)	1128 mm (44,4 in)	1500 mm (59,1 in)	120 mm (4,7 in)	50 mm (2 in)	500 mm (19,7 in)	5000 kg (11023 lb)	545 kg (1202 lb)
BCV8092	TCV0009	1405 mm (55,3 in)	1086 mm (42,8 in)	1400 mm (55,1 in)	120 mm (4,7 in)	45 mm (1,8 in)	500 mm (19,7 in)	3800 kg (8378 lb)	425 kg (937 lb)
BCV8294	TCV0010	1420 mm (55,9 in)	1150 mm (45,3 in)	1580 mm (62,2 in)	150 mm (5,9 in)	60 mm (2,4 in)	600 mm (23,6 in)	7500 kg (16535 lb)	555 kg (1224 lb)







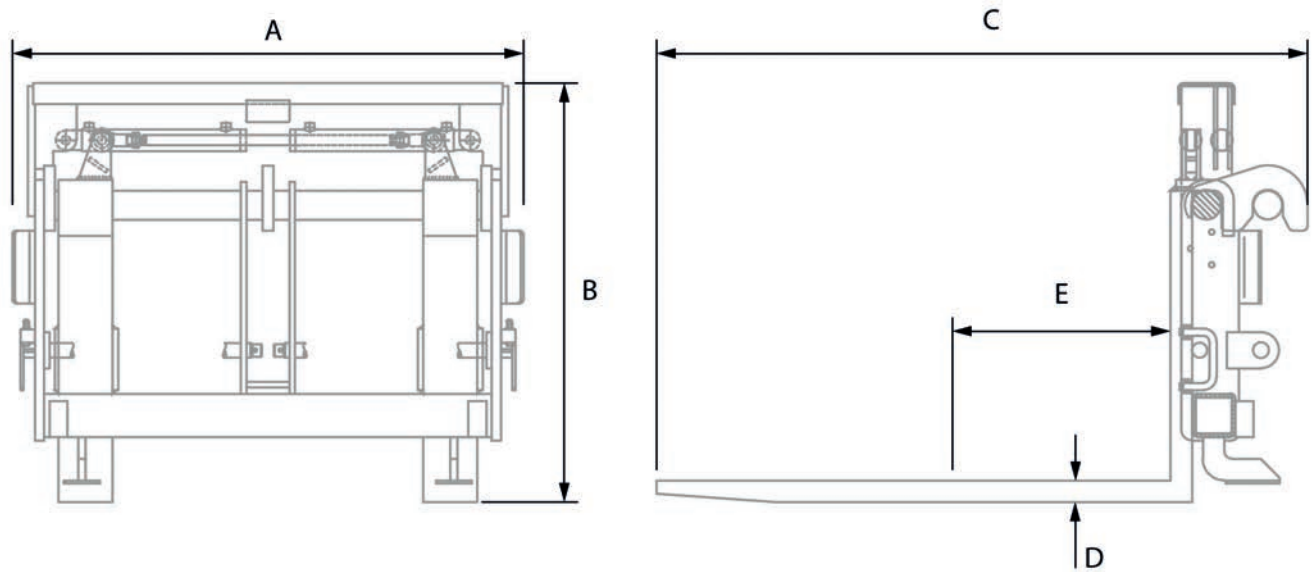

## Forks spreader shifter



This equipment is used to widen, tighten and move the forks to the right or left by a hydraulic control from the cab.

**Technical Data**



	Code								
BCV8286	TCV0019	2370 mm (93,3 in)	1462 mm (57,6 in)	1655 mm (65,2 in)	200 mm (7,9 in)	70 mm (2,8 in)	600 mm (23,6 in)	10000 kg (22046 lb)	1663 kg (3666 lb)
BCV8287	TCV0020	2370 mm (93,3 in)	1462 mm (57,6 in)	2255 mm (88,8 in)	200 mm (7,9 in)	70 mm (2,8 in)	900 mm (35,4 in)	8150 kg (17968 lb)	1800 kg (3968 lb)
BCV8288	TCV0021	2370 mm (93,3 in)	1592 mm (62,7 in)	2865 mm (112,8 in)	200 mm (7,9 in)	80 mm (3,1 in)	1200 mm (47,2 in)	8500 kg (18739 lb)	2000 kg (4409 lb)
BCV8302	TCV0022	2370 mm (93,3 in)	1592 mm (62,7 in)	2255 mm (88,8 in)	200 mm (7,9 in)	95 mm (3,7 in)	900 mm (35,4 in)	20000 kg (44092 lb)	2000 kg (4409 lb)
BCV8303	TCV0023	2370 mm (93,3 in)	1592 mm (62,7 in)	2865 mm (112,8 in)	200 mm (7,9 in)	95 mm (3,7 in)	1200 mm (47,2 in)	17300 kg (38140 lb)	2200 kg (4850 lb)



## Forks shifting unit









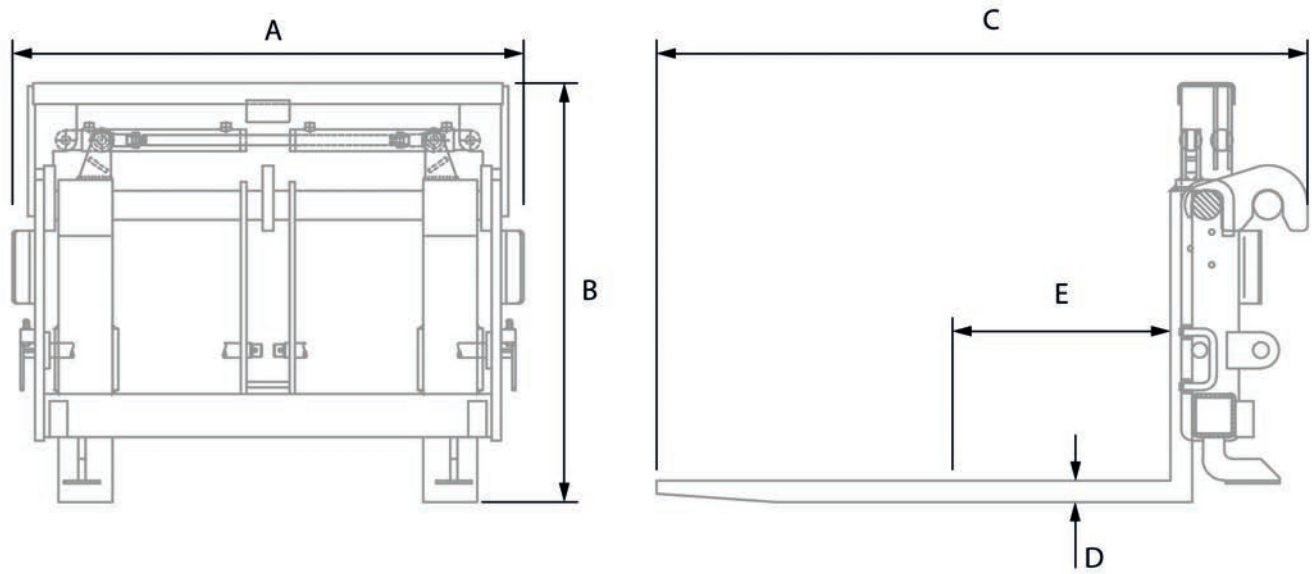

This equipment used to move the forks to the left or right by a hydraulic control from the cab.





**Technical Data**



	Code								
BCV8070	TCV0015	1170 mm (46,1 in)	755 mm (29,7 in)	1540 mm (60,6 in)	120 mm (4,7 in)	45 mm (1,8 in)	500 mm (19,7 in)	2500 kg (5512 lb)	320 kg (705 lb)
BCV8077	TCV0016	1470 mm (57,9 in)	755 mm (29,7 in)	1540 mm (60,6 in)	120 mm (4,7 in)	45 mm (1,8 in)	500 mm (19,7 in)	2500 kg (5512 lb)	350 kg (772 lb)

## Bucket

### 4 in 1 bucket



This equipment is suitable for loading and unloading operations. Thanks to the hydraulic opening it is suitable to grasp objects (also cylindrical), to dose aggregates unloading and to level the ground.

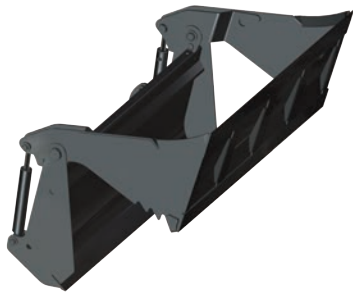



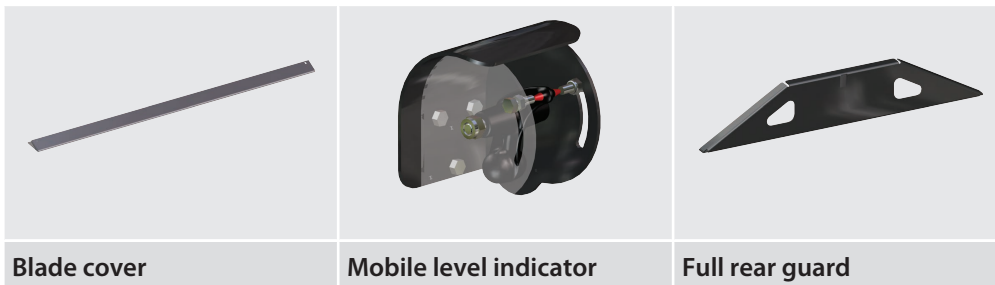

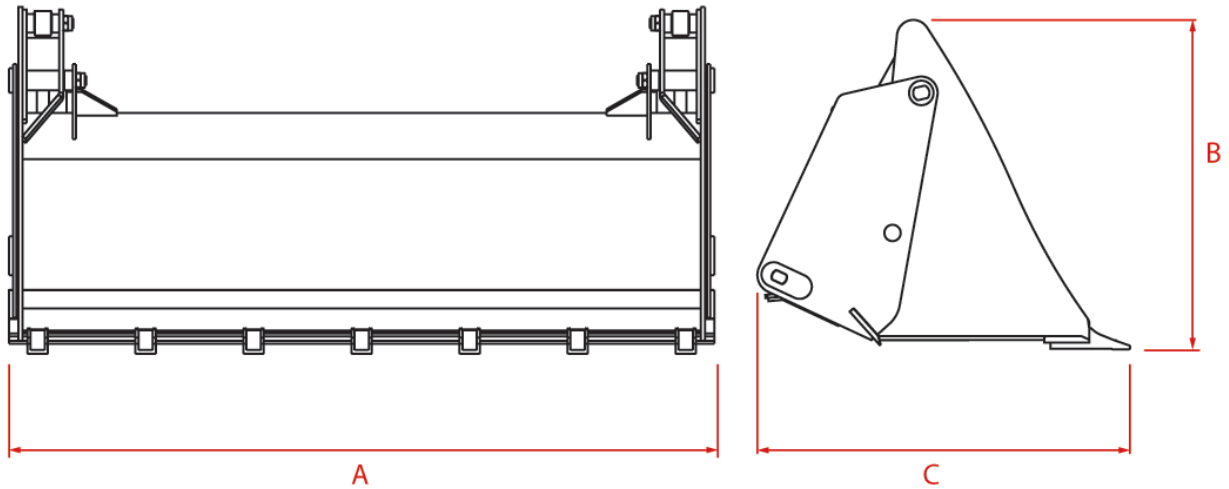

#### Optionals:



**Technical Data**



	Code							
BUB2669	TBN0215	2450 mm (96,5 in)	1313 mm (51,7 in)	1227 mm (48,3 in)	1,25 m <sup>3</sup> (44 ft <sup>3</sup> )	800 kg/m <sup>3</sup> (50 lb/ft <sup>3</sup> )	8	812 kg (1790 lb)
BUB2682	TBN0120	1980 mm (78 in)	1100 mm (43,3 in)	945 mm (37,2 in)	0,85 m <sup>3</sup> (30 ft <sup>3</sup> )	800 kg/m <sup>3</sup> (50 lb/ft <sup>3</sup> )	6	420 kg (926 lb)
BUB2682-S	TBN0118	1980 mm (78 in)	1100 mm (43,3 in)	945 mm (37,2 in)	0,85 m <sup>3</sup> (30 ft <sup>3</sup> )	800 kg/m <sup>3</sup> (50 lb/ft <sup>3</sup> )	6	453,5 kg (1000 lb)
BUB2683	TBN0119	1980 mm (78 in)	1105 mm (43,5 in)	945 mm (37,2 in)	0,85 m <sup>3</sup> (30 ft <sup>3</sup> )	800 kg/m <sup>3</sup> (50 lb/ft <sup>3</sup> )	6	431 kg (950 lb)
BUB2685	TBN0213	2400 mm (94,5 in)	1210 mm (47,6 in)	1024 mm (40,3 in)	1,0 m <sup>3</sup> (35 ft <sup>3</sup> )	800 kg/m <sup>3</sup> (50 lb/ft <sup>3</sup> )	8	658 kg (1451 lb)
BUB2685-S	TBN0216	2400 mm (94,5 in)	1210 mm (47,6 in)	1024 mm (40,3 in)	1,0 m <sup>3</sup> (35 ft <sup>3</sup> )	800 kg/m <sup>3</sup> (50 lb/ft <sup>3</sup> )	8	725 kg (1598 lb)
BUB2686	TBN0214	2400 mm (94,5 in)	1210 mm (47,6 in)	1120 mm (44,1 in)	1,0 m <sup>3</sup> (35 ft <sup>3</sup> )	800 kg/m <sup>3</sup> (50 lb/ft <sup>3</sup> )	8	655 kg (1444 lb)
BUB2686-S	TBN0217	2400 mm (94,5 in)	1210 mm (47,6 in)	1120 mm (44,1 in)	1,0 m <sup>3</sup> (35 ft <sup>3</sup> )	800 kg/m <sup>3</sup> (50 lb/ft <sup>3</sup> )	8	741 kg (1634 lb)
BUB2721	TBN0134	2400 mm (94,5 in)	1210 mm (47,6 in)	1024 mm (40,3 in)	1 m <sup>3</sup> (35 ft <sup>3</sup> )	800 kg/m <sup>3</sup> (50 lb/ft <sup>3</sup> )	8	658 kg (1451 lb)
BUB2721-S	TBN0135	2400 mm (94,5 in)	1210 mm (47,6 in)	1024 mm (40,3 in)	1 m <sup>3</sup> (35 ft <sup>3</sup> )	800 kg/m <sup>3</sup> (50 lb/ft <sup>3</sup> )	8	725 kg (1598 lb)
BUB2723	TBN0173	1980 mm (78 in)	1105 mm (43,5 in)	910 mm (35,8 in)	0,85 m <sup>3</sup> (30 ft <sup>3</sup> )	800 kg/m <sup>3</sup> (50 lb/ft <sup>3</sup> )	6	427 kg (941 lb)
BUB2723-S	TBN0175	1980 mm (78 in)	1105 mm (43,5 in)	910 mm (35,8 in)	0,85 m <sup>3</sup> (30 ft <sup>3</sup> )	800 kg/m <sup>3</sup> (50 lb/ft <sup>3</sup> )	6	462,5 kg (1020 lb)

BUB2724	TBN0174	1980 mm (78 in)	1105 mm (43,5 in)	995 mm (39,2 in)	0,85 m <sup>3</sup> (30 ft <sup>3</sup> )	800 kg/m <sup>3</sup> (50 lb/ft <sup>3</sup> )	6	430 kg (948 lb)
BUB2724-S	TBN0176	1980 mm (78 in)	1105 mm (43,5 in)	995 mm (39,2 in)	0,85 m <sup>3</sup> (30 ft <sup>3</sup> )	800 kg/m <sup>3</sup> (50 lb/ft <sup>3</sup> )	6	469,5 kg (1035 lb)
BUB2740	TBN0133	2400 mm (94,5 in)	1210 mm (47,6 in)	1024 mm (40,3 in)	1 m <sup>3</sup> (35 ft <sup>3</sup> )	800 kg/m <sup>3</sup> (50 lb/ft <sup>3</sup> )	8	680,5 kg (1500 lb)



## Bucket for silage with grab





This equipment is intended for loading, unloading and handling bulk materials, such as silage, grains and chips.

Thanks to the use of the holder, the bucket is used to its full potential, thus providing a greater load capacity, as the material is held in the bucket volumetric load capacity.



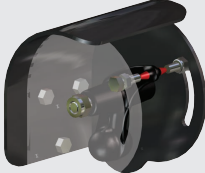

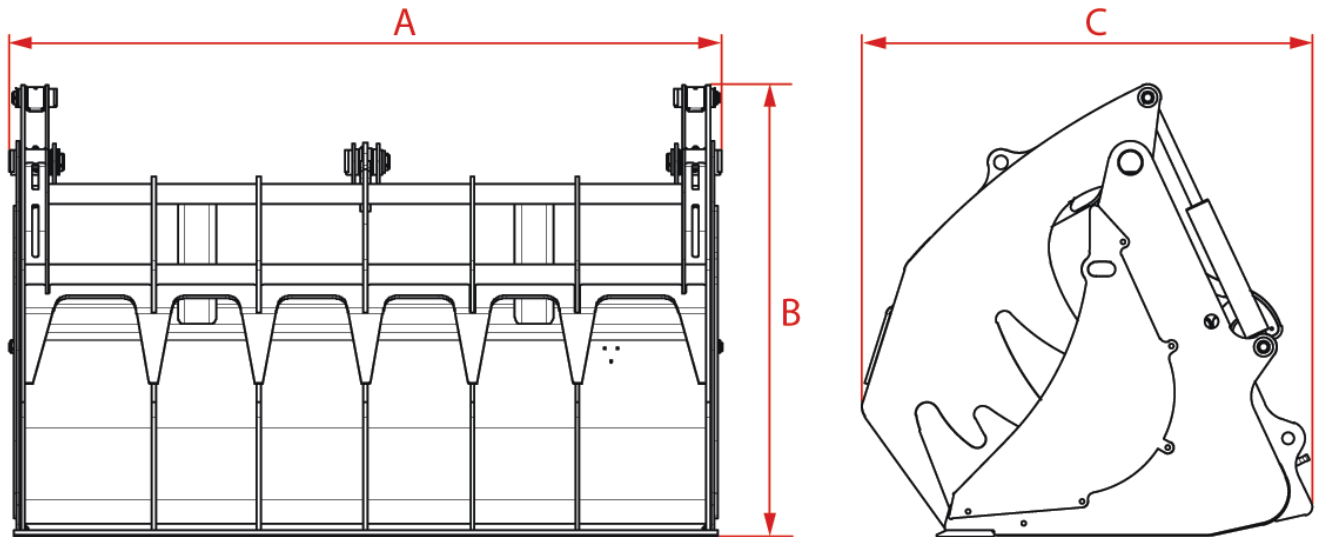

### Optionals:

		
<p>Blade cover</p>	<p>Mobile level indicator</p>	<p>Split rear guard</p>

**Technical Data**



	Code	A	B	C				
BUB2667	TBN0226	2450 mm (96,5 in)	1570 mm (61,8 in)	1570 mm (61,8 in)	2,5 m <sup>3</sup> (88 ft <sup>3</sup> )	800 kg/m <sup>3</sup> (50 lb/ft <sup>3</sup> )	8	1200,5 kg (2647 lb)
BUB2667-S	TBN0229	2450 mm (96,5 in)	1570 mm (61,8 in)	1570 mm (61,8 in)	2,5 m <sup>3</sup> (88 ft <sup>3</sup> )	800 kg/m <sup>3</sup> (50 lb/ft <sup>3</sup> )	8	1269 kg (2798 lb)
BUB2736	TBN0224	2400 mm (94,5 in)	1260 mm (49,6 in)	1000 mm (39,4 in)	1,5 m <sup>3</sup> (53 ft <sup>3</sup> )	800 kg/m <sup>3</sup> (50 lb/ft <sup>3</sup> )	8	836,5 kg (1844 lb)
BUB2736-S	TBN0227	2400 mm (94,5 in)	1260 mm (49,6 in)	1000 mm (39,4 in)	1,5 m <sup>3</sup> (53 ft <sup>3</sup> )	800 kg/m <sup>3</sup> (50 lb/ft <sup>3</sup> )	8	903,5 kg (1992 lb)
BUB2737	TBN0139	2400 mm (94,5 in)	1260 mm (49,6 in)	1080 mm (42,5 in)	1,5 m <sup>3</sup> (53 ft <sup>3</sup> )	800 kg/m <sup>3</sup> (50 lb/ft <sup>3</sup> )	8	836,5 kg (1844 lb)
BUB2737-S	TBN0140	2400 mm (94,5 in)	1260 mm (49,6 in)	1080 mm (42,5 in)	1,5 m <sup>3</sup> (53 ft <sup>3</sup> )	800 kg/m <sup>3</sup> (50 lb/ft <sup>3</sup> )	8	903,5 kg (1992 lb)
BUB2738	TBN0225	2400 mm (94,5 in)	1260 mm (49,6 in)	1060 mm (41,7 in)	1,5 m <sup>3</sup> (53 ft <sup>3</sup> )	800 kg/m <sup>3</sup> (50 lb/ft <sup>3</sup> )	8	832 kg (1834 lb)
BUB2738-S	TBN0228	2400 mm (94,5 in)	1260 mm (49,6 in)	1060 mm (41,7 in)	1,5 m <sup>3</sup> (53 ft <sup>3</sup> )	800 kg/m <sup>3</sup> (50 lb/ft <sup>3</sup> )	8	899 kg (1982 lb)

## Bucket for manure and generic material with grab



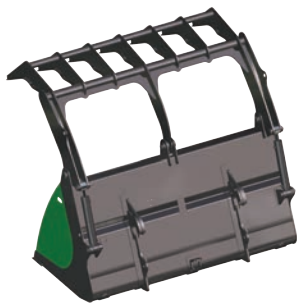

This equipment is intended for loading, unloading and handling bulk materials, such as manure, non-hazardous waste in a compactable form and timber.

Thanks to the use of the holder the bucket is used at its full potential, thus providing a greater load capacity, as the material can be compressed and held in the bucket volumetric load capacity.



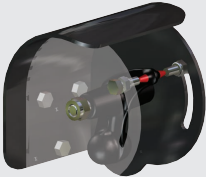



### Optionals:

		
Blade cover	Mobile level indicator	Split rear guard

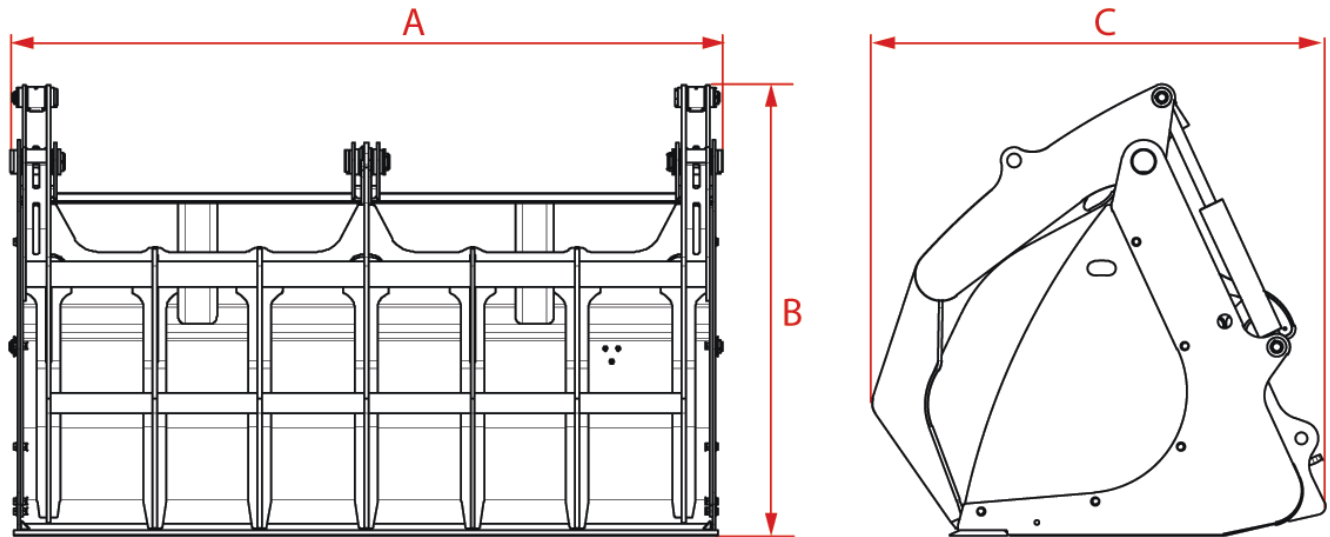

**Technical Data**



	Code	A	B	C				
BUB2666	TBN0220	2450 mm (96,5 in)	1600 mm (63 in)	1780 mm (70,1 in)	2,5 m <sup>3</sup> (88 ft <sup>3</sup> )	800 kg/m <sup>3</sup> (50 lb/ft <sup>3</sup> )	8	1169,5 kg (2578 lb)
BUB2666-S	TBN0223	2450 mm (96,5 in)	1600 mm (63 in)	1780 mm (70,1 in)	2,5 m <sup>3</sup> (88 ft <sup>3</sup> )	800 kg/m <sup>3</sup> (50 lb/ft <sup>3</sup> )	8	1237,5 kg (2728 lb)
BUB2672	TBN0126	1980 mm (78 in)	1200 mm (47,2 in)	1270 mm (50 in)	1,25 m <sup>3</sup> (44 ft <sup>3</sup> )	800 kg/m <sup>3</sup> (50 lb/ft <sup>3</sup> )	6	571 kg (1259 lb)
BUB2672-S	TBN0113	1980 mm (78 in)	1200 mm (47,2 in)	1270 mm (50 in)	1,25 m <sup>3</sup> (44 ft <sup>3</sup> )	800 kg/m <sup>3</sup> (50 lb/ft <sup>3</sup> )	6	604,5 kg (1333 lb)
BUB2687	TBN0218	2400 mm (94,5 in)	1260 mm (49,6 in)	1255 mm (49,4 in)	1,5 m <sup>3</sup> (53 ft <sup>3</sup> )	800 kg/m <sup>3</sup> (50 lb/ft <sup>3</sup> )	8	811 kg (1788 lb)
BUB2687-S	TBN0221	2400 mm (94,5 in)	1260 mm (49,6 in)	1255 mm (49,4 in)	1,5 m <sup>3</sup> (53 ft <sup>3</sup> )	800 kg/m <sup>3</sup> (50 lb/ft <sup>3</sup> )	8	878 kg (1936 lb)
BUB2688	TBN0219	2400 mm (94,5 in)	1250 mm (49,2 in)	1245 mm (49 in)	1,5 m <sup>3</sup> (53 ft <sup>3</sup> )	800 kg/m <sup>3</sup> (50 lb/ft <sup>3</sup> )	8	811 kg (1788 lb)
BUB2688-S	TBN0222	2400 mm (94,5 in)	1250 mm (49,2 in)	1245 mm (49 in)	1,5 m <sup>3</sup> (53 ft <sup>3</sup> )	800 kg/m <sup>3</sup> (50 lb/ft <sup>3</sup> )	8	878 kg (1936 lb)
BUB2722	TBN0137	2400 mm (94,5 in)	1255 mm (49,4 in)	1255 mm (49,4 in)	1,5 m <sup>3</sup> (53 ft <sup>3</sup> )	800 kg/m <sup>3</sup> (50 lb/ft <sup>3</sup> )	8	811 kg (1788 lb)
BUB2722-S	TBN0138	2400 mm (94,5 in)	1255 mm (49,4 in)	1255 mm (49,4 in)	1,5 m <sup>3</sup> (53 ft <sup>3</sup> )	800 kg/m <sup>3</sup> (50 lb/ft <sup>3</sup> )	8	878 kg (1936 lb)
BUB2725	TBN0177	1980 mm (78 in)	1205 mm (47,4 in)	1235 mm (48,6 in)	1,25 m <sup>3</sup> (44 ft <sup>3</sup> )	800 kg/m <sup>3</sup> (50 lb/ft <sup>3</sup> )	6	582 kg (1283 lb)
BUB2725-S	TBN0179	1980 mm (78 in)	1205 mm (47,4 in)	1235 mm (48,6 in)	1,25 m <sup>3</sup> (44 ft <sup>3</sup> )	800 kg/m <sup>3</sup> (50 lb/ft <sup>3</sup> )	6	617,5 kg (1361 lb)

BUB2726	TBN0178	1980 mm (78 in)	1205 mm (47,4 in)	1320 mm (52 in)	1,25 m <sup>3</sup> (44 ft <sup>3</sup> )	800 kg/m <sup>3</sup> (50 lb/ft <sup>3</sup> )	6	582 kg (1283 lb)
BUB2726-S	TBN0180	1980 mm (78 in)	1205 mm (47,4 in)	1320 mm (52 in)	1,25 m <sup>3</sup> (44 ft <sup>3</sup> )	800 kg/m <sup>3</sup> (50 lb/ft <sup>3</sup> )	6	617,5 kg (1361 lb)



## Bucket for fodder with grab

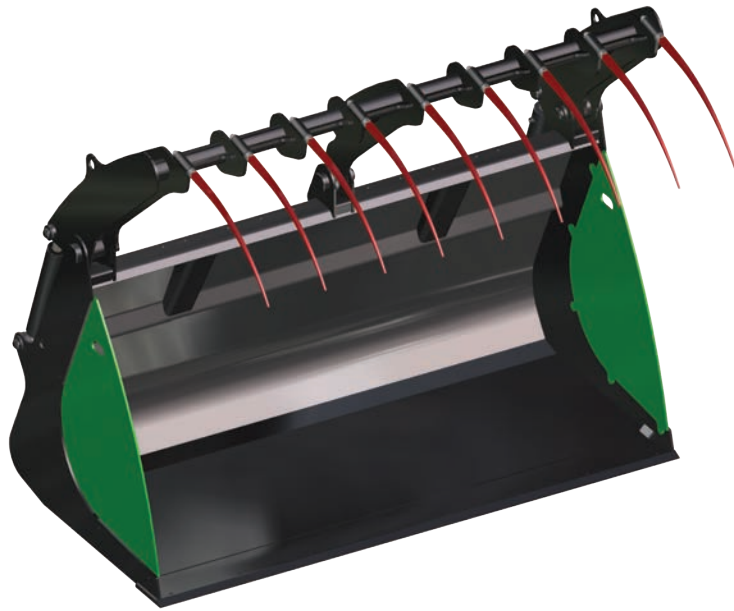



This equipment is intended for loading, unloading and handling bulk fodder.

Thanks to the use of the holder, the bucket is used to its full potential, thus providing a greater load capacity, as the material is held in the bucket volumetric load capacity.



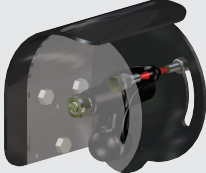



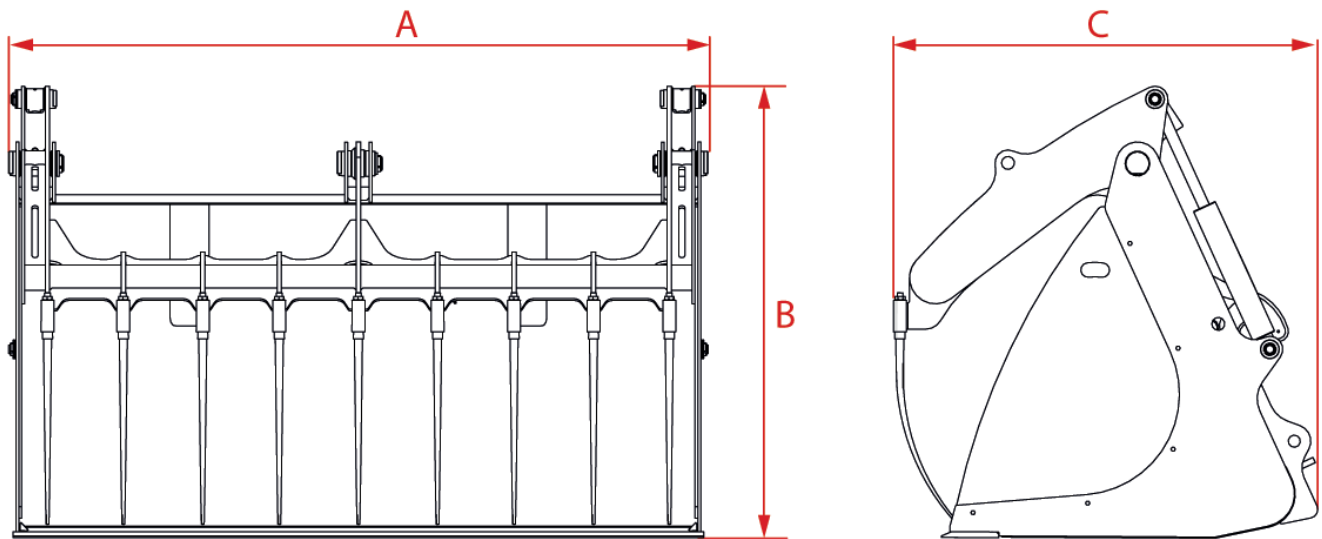

### Optionals:

		
<p>Blade cover</p>	<p>Mobile level indicator</p>	<p>Split rear guard</p>

**Technical Data**



	Code						
BUB2765	TBN0254	2450 mm (96,5 in)	1370 mm (53,9 in)	1475 mm (58,1 in)	2,5 m <sup>3</sup> (88 ft <sup>3</sup> )	8	1055 kg (2326 lb)
BUB2727	TBN0246	2400 mm (94,5 in)	1250 mm (49,2 in)	1180 mm (46,5 in)	1,5 m <sup>3</sup> (53 ft <sup>3</sup> )	8	748,5 kg (1650 lb)
BUB2728	-	2400 mm (94,5 in)	1250 mm (49,2 in)	1170 mm (46,1 in)	1,5 m <sup>3</sup> (53 ft <sup>3</sup> )	8	748,5 kg (1650 lb)
BUB2729	TBN0259	2400 mm (94,5 in)	1250 mm (49,2 in)	1170 mm (46,1 in)	1,5 m <sup>3</sup> (53 ft <sup>3</sup> )	8	744 kg (1640 lb)

## Mixing bucket







The mixing bucket is the ideal device to produce fresh cement in any condition with unparalleled ease and speed. In addition to the significant reduction in operating costs, using this equipment is essential in many cases, for example when there is no electric current available for using classic concrete mixer.

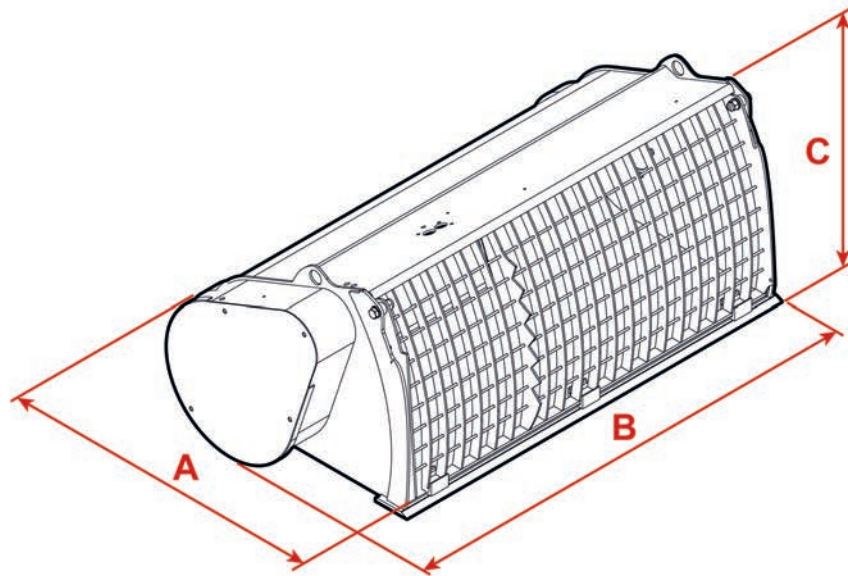

**Technical Data**



	Code					
BUD3040	TBN0051	1700 mm (66,9 in)	720 mm (28,3 in)	820 mm (32,3 in)	500 L (132,09 gal)	680 kg (1499 lb)
BUD3057	TBN0079	1700 mm (66,9 in)	630 mm (24,8 in)	750 mm (29,5 in)	350 L (92,46 gal)	400 kg (882 lb)
BUD3058	TBN0077	1700 mm (66,9 in)	630 mm (24,8 in)	750 mm (29,5 in)	350 L (92,46 gal)	447 kg (985 lb)
BUD3060	TBN0034	1700 mm (66,9 in)	630 mm (24,8 in)	750 mm (29,5 in)	350 L (92,46 gal)	440 kg (970 lb)
BUD3062	TBN0088	1700 mm (66,9 in)	630 mm (24,8 in)	750 mm (29,5 in)	350 L (92,46 gal)	440 kg (970 lb)
BUD3063	TBN0035	1700 mm (66,9 in)	720 mm (28,3 in)	820 mm (32,3 in)	500 L (132,09 gal)	680 kg (1499 lb)
BUD3065	TBN0089	1700 mm (66,9 in)	720 mm (28,3 in)	820 mm (32,3 in)	500 L (132,09 gal)	680 kg (1499 lb)
BUD3066	TBN0066	1760 mm (69,3 in)	720 mm (28,3 in)	820 mm (32,3 in)	600 L (158,5 gal)	700 kg (1543 lb)



## Ladle



This equipment is ideal for loading and transporting concrete, or for cleaning and emptying facilities from construction waste.



Equipped with hydraulic opening that can be operated from the cab.



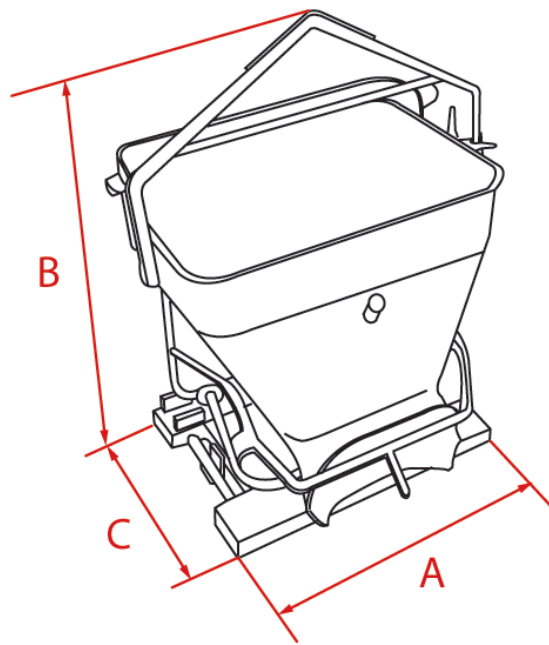

**Technical Data**



	Code	<b>A</b>	<b>B</b>	<b>C</b>		
BUD3020	TGN0012	1200 mm (47,2 in)	1460 mm (57,5 in)	1400 mm (55,1 in)	400 L (105,67 gal)	212 kg (467 lb)
BUD3021	TGN0015	1200 mm (47,2 in)	1260 mm (49,6 in)	1400 mm (55,1 in)	600 L (158,5 gal)	228 kg (503 lb)

## Forks





### Fork for logs

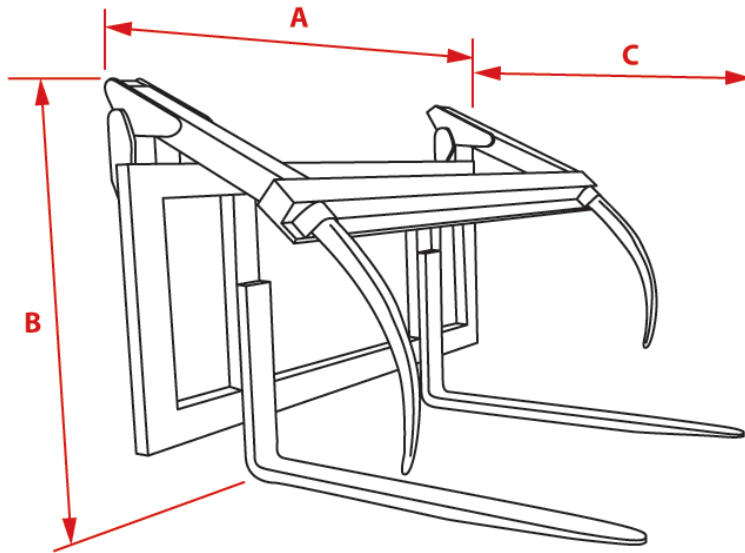

Equipment suitable for feeding forest separation plants, in industrial sawmills and for handling and storing wood and log stacks. Equipped with a hydraulically operated closing grid, it is also effective for unloading timber from trailers and for sorting whole logs.

**Technical Data**



	Code	A 	B 	C 	
BUD1033	TGN0009	1300 mm (51,2 in)	960 mm (37,8 in)	1446 mm (56,9 in)	300 kg (661 lb)
BUD1168	TGN0020	1300 mm (51,2 in)	960 mm (37,8 in)	1563 mm (61,5 in)	340 kg (750 lb)

## Multipurpose fork with holder

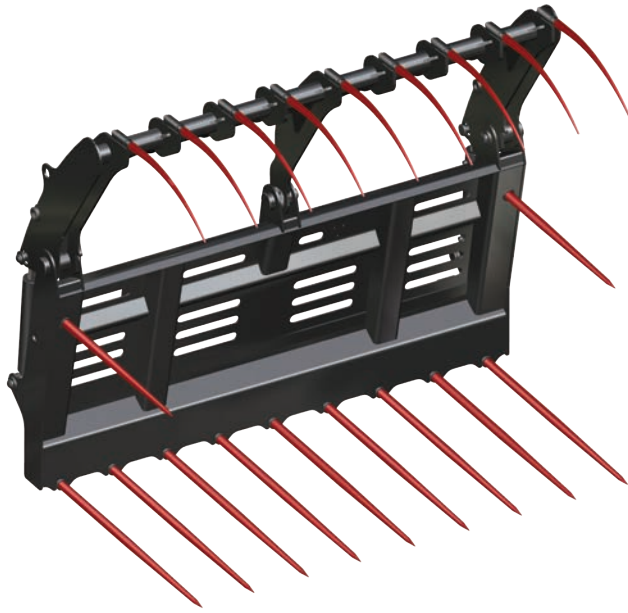

This equipment is ideal for use in handling very dense semi-solid material such as manure, peat, wet wood chips and more. The reduced distance between the teeth almost completely eliminates the outflow of the material. The holder has a double function, on the one hand it facilitates the detachment of the material from the pile and on the other, once tightened, it holds it firmly to the fork.

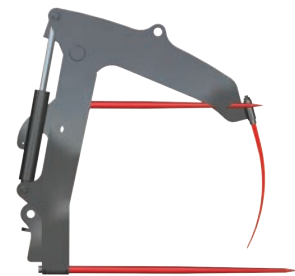
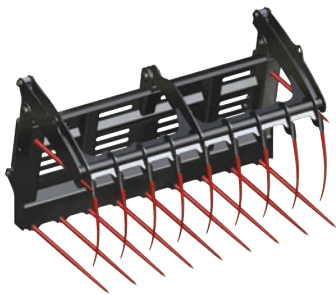

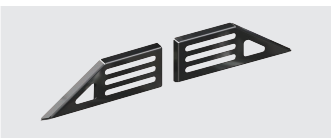

### Optionals:

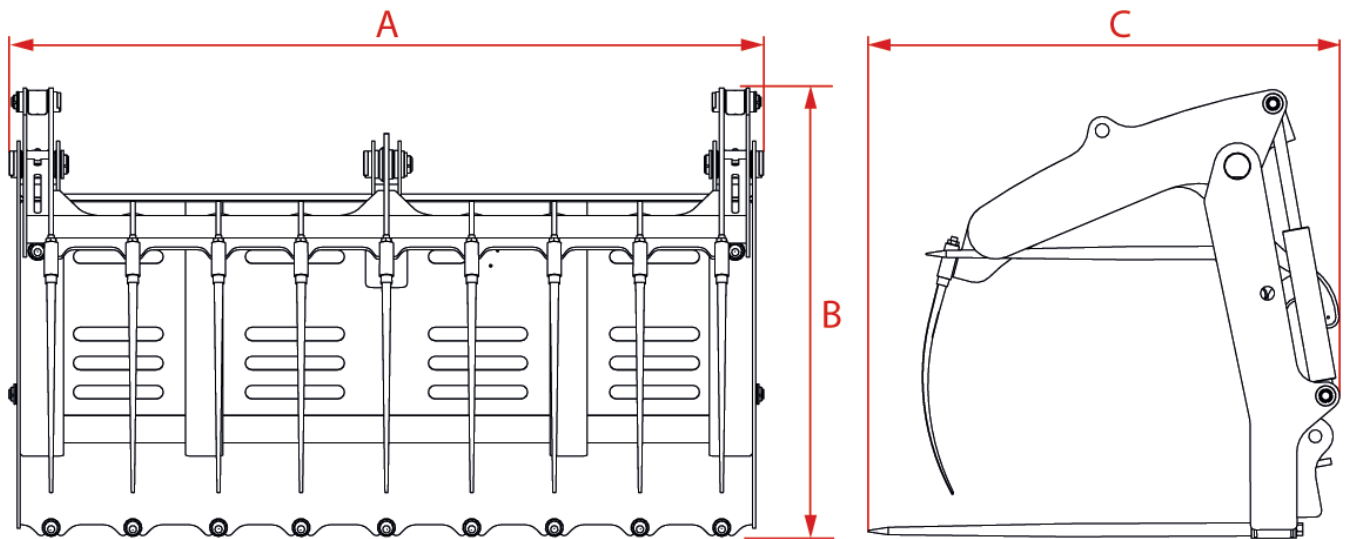

Split rear guard

**Technical Data**



	Code	A	B	C		
BUD1028	TGN0013	2420 mm (95,3 in)	1100 mm (43,3 in)	970 mm (38,2 in)	850 kg (1874 lb)	450 kg (992 lb)
BUD1031	TGN0010	2420 mm (95,3 in)	1100 mm (43,3 in)	960 mm (37,8 in)	850 kg (1874 lb)	370 kg (816 lb)
BUD1070	TGN0037	2420 mm (95,3 in)	1100 mm (43,3 in)	950 mm (37,4 in)	850 kg (1874 lb)	350 kg (772 lb)
BUD1073	TGN0021	2420 mm (95,3 in)	1100 mm (43,3 in)	970 mm (38,2 in)	850 kg (1874 lb)	450 kg (992 lb)

## Blades

### Angledozer blade



Blade suitable for excavation, spreading and leveling of soil with double-acting hydraulic cylinders for left and right angles.

**Technical Data**

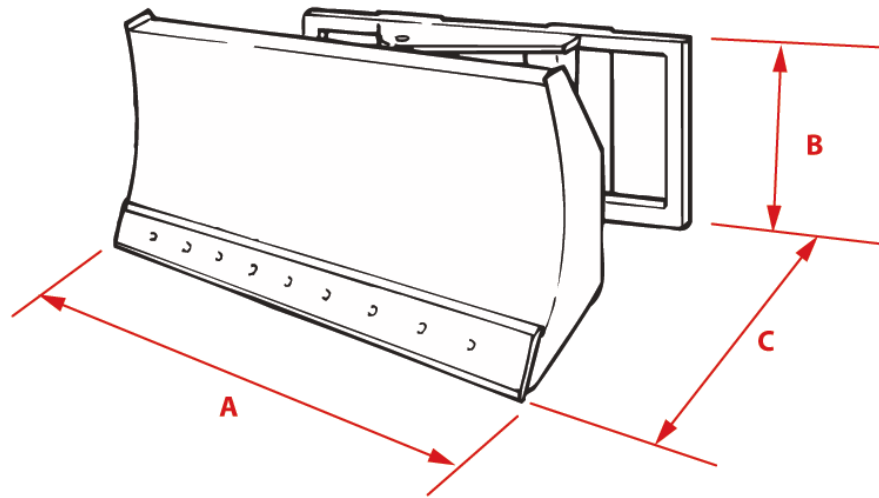

	Code	<b>A</b>	<b>B</b>	<b>C</b>	
BUD1170	-	1820 mm (71,7 in)	563 mm (22,2 in)	611 mm (24,1 in)	188 kg (414 lb)
BUD1171	-	1820 mm (71,7 in)	563 mm (22,2 in)	611 mm (24,1 in)	188 kg (414 lb)
BUD1175	TGN0043	2120 mm (83,5 in)	660 mm (26 in)	611 mm (24,1 in)	213 kg (470 lb)
BUD1176	TGN0039	2100 mm (82,7 in)	660 mm (26 in)	611 mm (24,1 in)	213 kg (470 lb)
BUD1195	TGN0026	2400 mm (94,5 in)	660 mm (26 in)	611 mm (24,1 in)	315 kg (694 lb)

## Snow plough

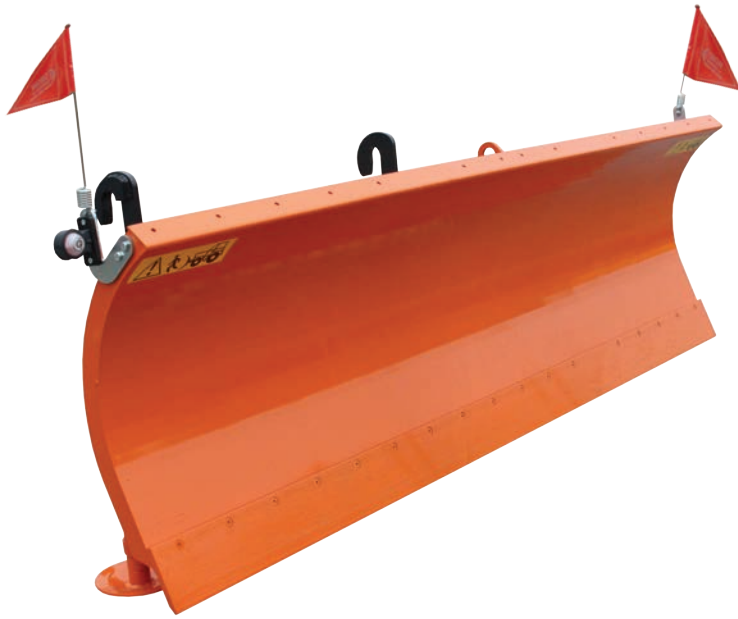



Snow plough with shock-proof tipping system with spring return, horizontal self leveling and left-right rotation.



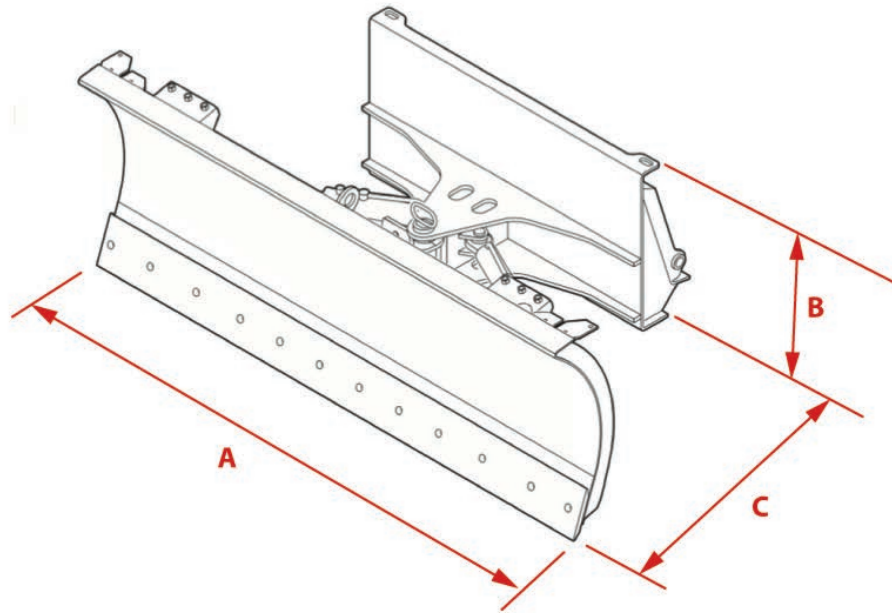

**Technical Data**



	Code	<b>A</b>	<b>B</b>	<b>C</b>	
BUD1166	-	1800 mm (70,9 in)	700 mm (27,6 in)	900 mm (35,4 in)	280 kg (617 lb)
BUD1172	-	1800 mm (70,9 in)	700 mm (27,6 in)	900 mm (35,4 in)	280 kg (617 lb)
BUD1217	TGN0072	2700 mm (106,3 in)	800 mm (31,5 in)	900 mm (35,4 in)	450 kg (992 lb)
BUD1196	TGN0027	2400 mm (94,5 in)	700 mm (27,6 in)	900 mm (35,4 in)	410 kg (904 lb)
BUD1179	TGN0044	2100 mm (82,7 in)	820 mm (32,3 in)	1130 mm (44,5 in)	480 kg (1058 lb)
BUD1180	TGN0040	2100 mm (82,7 in)	820 mm (32,3 in)	1130 mm (44,5 in)	480 kg (1058 lb)

## Tiltadozer blade

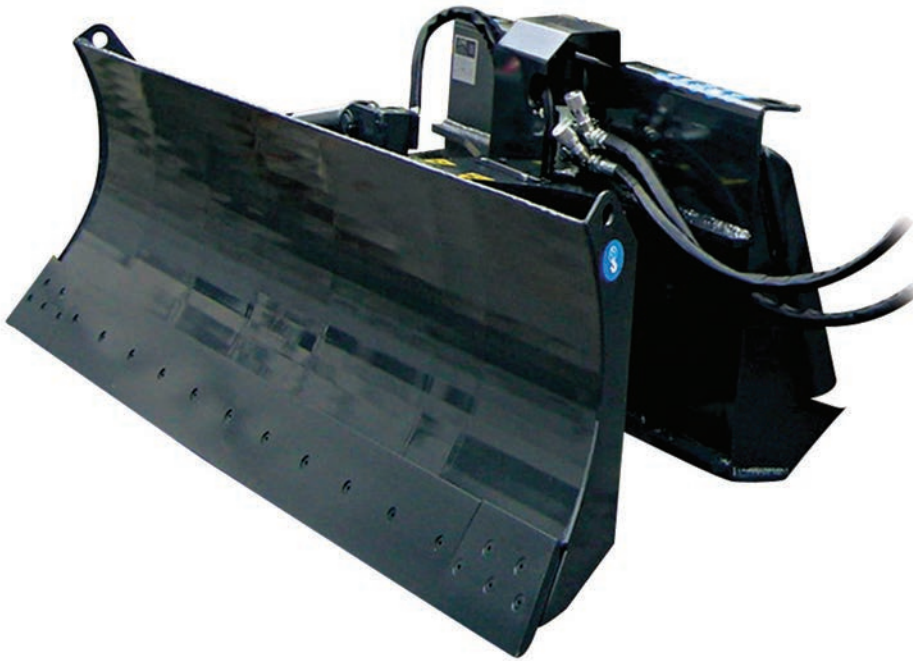

This blade is used to level the ground with absolute accuracy ensuring maximum productivity even in small spaces with double-acting cylinders for oscillation (TILT) and left-right hydraulic angle.

**Technical Data**

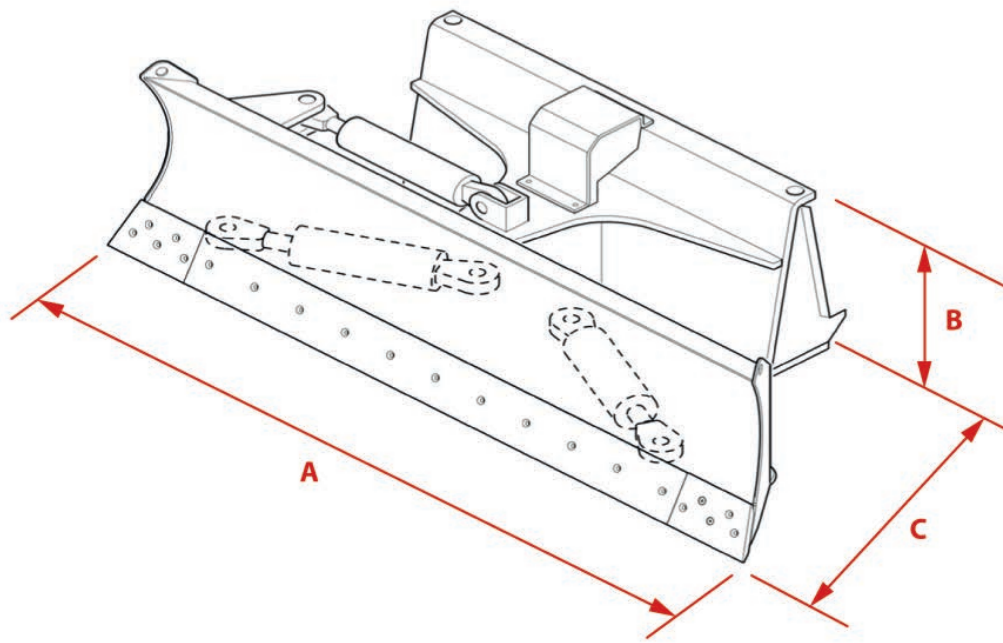

	Code	<b>A</b>	<b>B</b>	<b>C</b>	
BUD1173	-	2100 mm (82,7 in)	540 mm (21,3 in)	820 mm (32,3 in)	380 kg (838 lb)
BUD1174	-	2100 mm (82,7 in)	540 mm (21,3 in)	820 mm (32,3 in)	380 kg (838 lb)
BUD1177	TGN0045	2400 mm (94,5 in)	540 mm (21,3 in)	820 mm (32,3 in)	420 kg (926 lb)
BUD1178	TGN0038	2400 mm (94,5 in)	540 mm (21,3 in)	820 mm (32,3 in)	420 kg (926 lb)
BUD1197	TGN0028	2400 mm (94,5 in)	540 mm (21,3 in)	820 mm (32,3 in)	420 kg (926 lb)

## Grippers

### Clamp for big wrapped bales



This clamp is designed to handle wrapped hay bales, the smooth and rounded tubular structure avoids damage to the protective film.

**Technical Data**

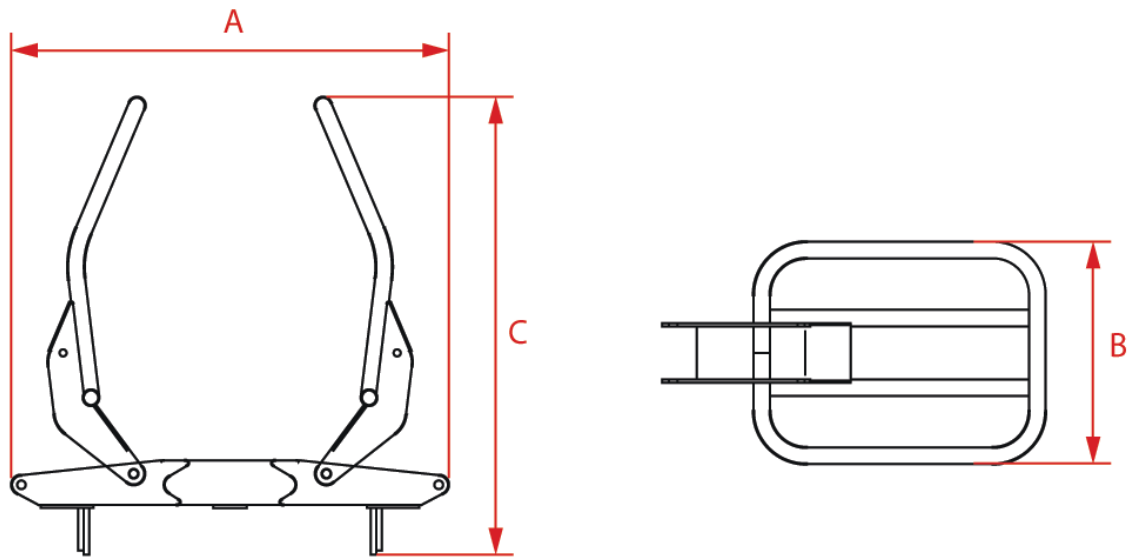

	Code	<b>A</b>	<b>B</b>	<b>C</b>	
BUD4027	TGN0035	1574 mm (62 in)	800 mm (31,5 in)	1643 mm (64,7 in)	247 kg (545 lb)
BUD4058	TGN0017	1574 mm (62 in)	800 mm (31,5 in)	1643 mm (64,7 in)	247 kg (545 lb)
BUD4075	TGN0003	1574 mm (62 in)	800 mm (31,5 in)	1643 mm (64,7 in)	247 kg (545 lb)

## Gripper for cylinders



This clamp has been designed to handle various types of cylinders. The possibility of rotating and tilting makes it indispensable in maintenance operations of large machinery such as dumpers and mine excavators.



**Technical Data**

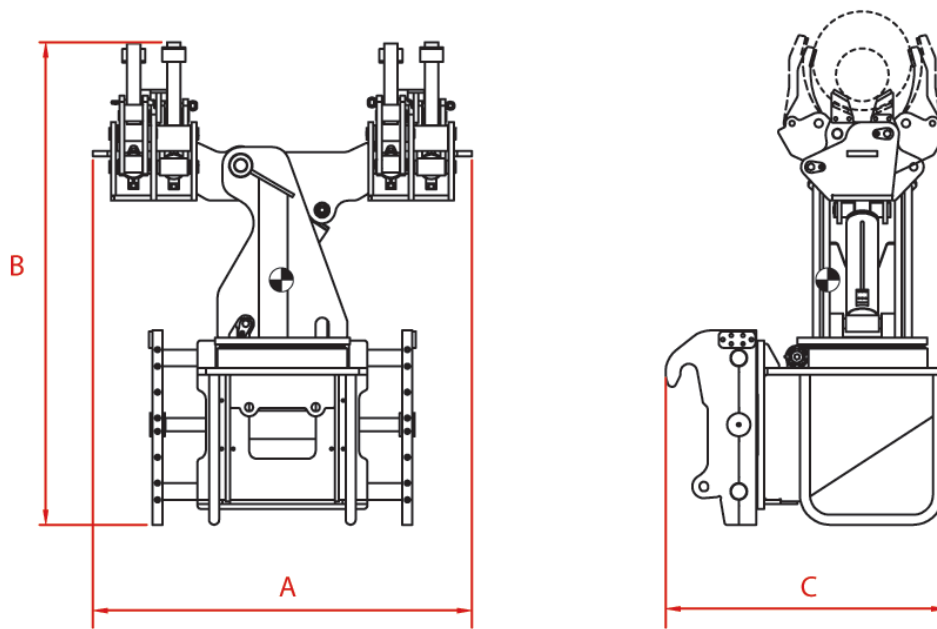

	Code	A	B	C	
BUD4056	TGN0068	2276 mm (89,6 in)	2984 mm (117,5 in)	1546 mm (60,9 in)	4320 kg (9524 lb)

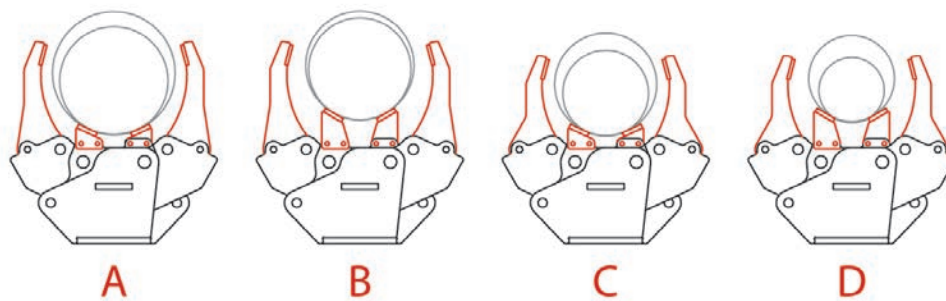

A	ASM0000355 (Long)	ASM0000357 (Low)	530 mm (20.86 in)	600 mm (23.62 in)
B	ASM0000355 (Long)	ASM0000360 (High)	530 mm (20.86 in)	500 mm (19.68 in)
C	ASM0000356 (Short)	ASM0000357 (Low)	500 mm (19.68 in)	420 mm (16.53 in)
D	ASM0000356 (Short)	ASM0000360 (High)	420 mm (16.53 in)	320 mm (12.59 in)



## Grab clamp for two roll bales





This equipment has been designed to move one or two wrapped roll bales. The combination of the equipment functionality and the vehicle capacities makes it particularly useful for loading and unloading trailers.



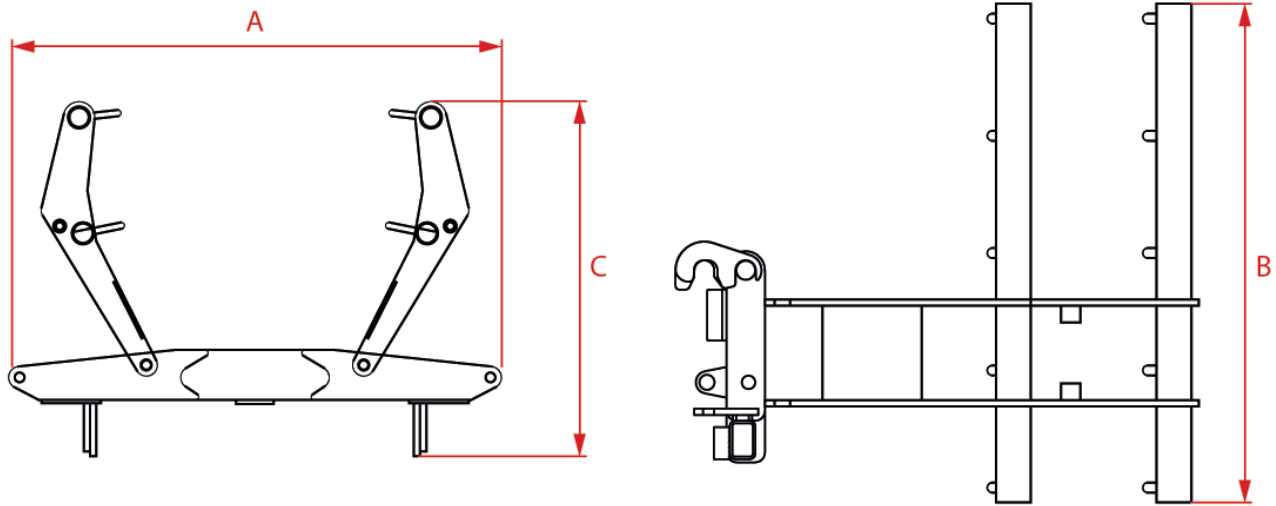

**Technical Data**



	Code	<b>A</b>	<b>B</b>	<b>C</b>	
BUD4036	TGN0034	2100 mm (82,7 in)	1550 mm (61 in)	951 mm (37,4 in)	340 kg (750 lb)
BUD4056	TGN0068	2276 mm (89,6 in)	2984 mm (117,5 in)	1546 mm (60,9 in)	4320 kg (9524 lb)
BUD4057	TGN0016	2100 mm (82,7 in)	1550 mm (61 in)	951 mm (37,4 in)	340 kg (750 lb)

## Gripper for tires

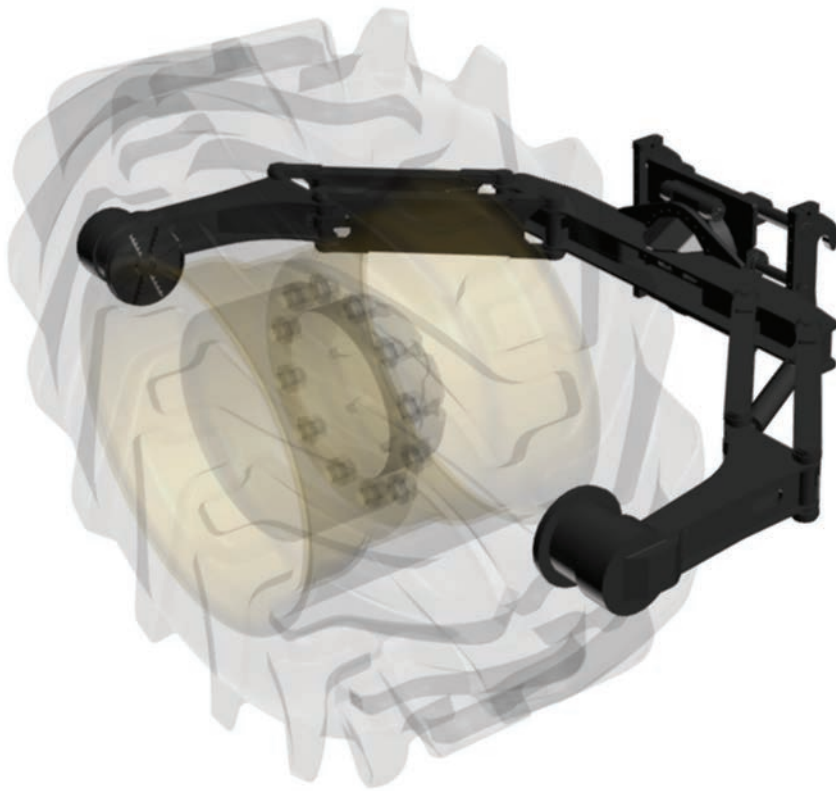

This gripper has been designed to handle various types of tires. The possibility of rotating and tilting makes it indispensable in maintenance operations of large machinery such as mine dumpers.



**Technical Data**

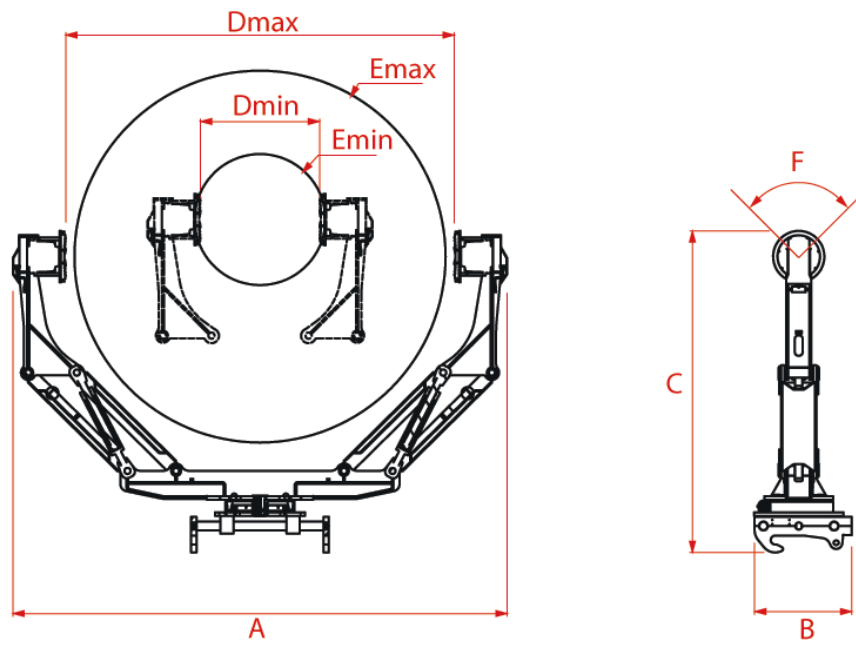

	TGN0069	0
<b>A</b>	5594 mm (220,2 in)	4144 mm (163,1 in)
<b>B</b>	1100 mm (43,3 in)	1156 mm (45,5 in)
<b>C</b>	3632 mm (143 in)	3592 mm (141,4 in)
<b>Max D</b>	4398 mm (173.1 in)	3558 mm (140.1 in)
<b>Min D</b>	1480 mm (58.3 in)	1458 mm (57.4 in)
<b>Max E</b>	4200 mm (165.4 in)	3400 mm (133.9 in)
<b>Min E</b>	1340 mm (52.8 in)	1300 mm (51.2 in)
<b>F</b>	360°	97°
<b>Weight</b>	4680 kg (10318 lb)	3350 kg (7385 lb)



## Orange-peel grabber

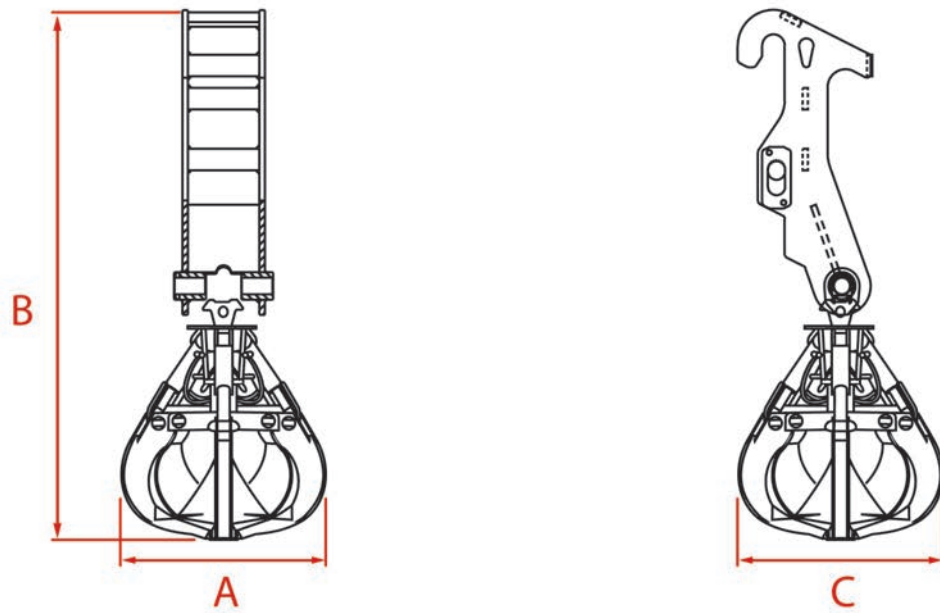

The orange-peel grabber is a hydraulic equipment suitable for handling loose materials such as scrap, urban waste, industrial waste, processing waste, boulders, paper, cardboard, plastic, wood and tires. Therefore it is mainly used in the recycling and disposal sector.

**Technical Data**



	Code	<b>A</b>	<b>B</b>	<b>C</b>		
BUB2441	TGN0023	1020 mm (40,2 in)	1700 mm (66,9 in)	1020 mm (40,2 in)	0,23 m <sup>3</sup> (8 ft <sup>3</sup> )	330 kg (728 lb)
BUB2453	TGN0057	1020 mm (40,2 in)	1750 mm (68,9 in)	1020 mm (40,2 in)	0,23 m <sup>3</sup> (8 ft <sup>3</sup> )	300 kg (661 lb)

## Centring handler

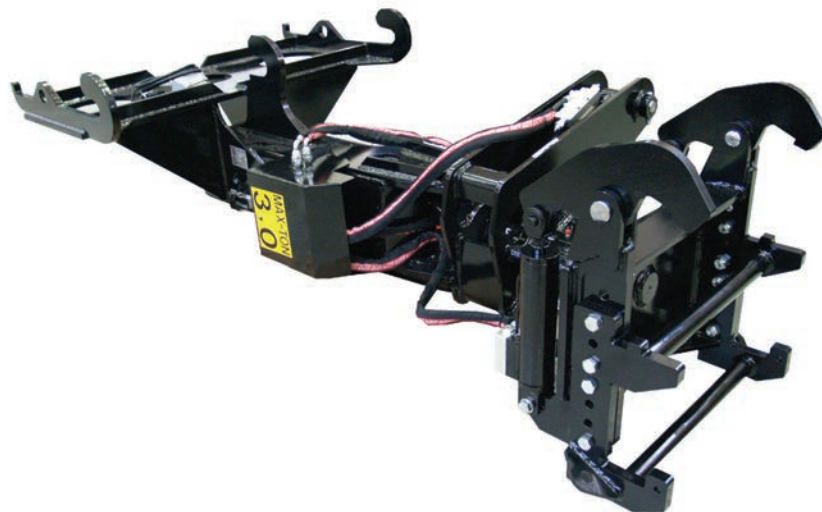

Equipment designed to position the centring arches that will form the tunnels supporting arches. The possibility of rotating and tilting maximizes the precision in laying operations. The centring handler can be adjusted to adapt to the various types of arches.

## Technical Data

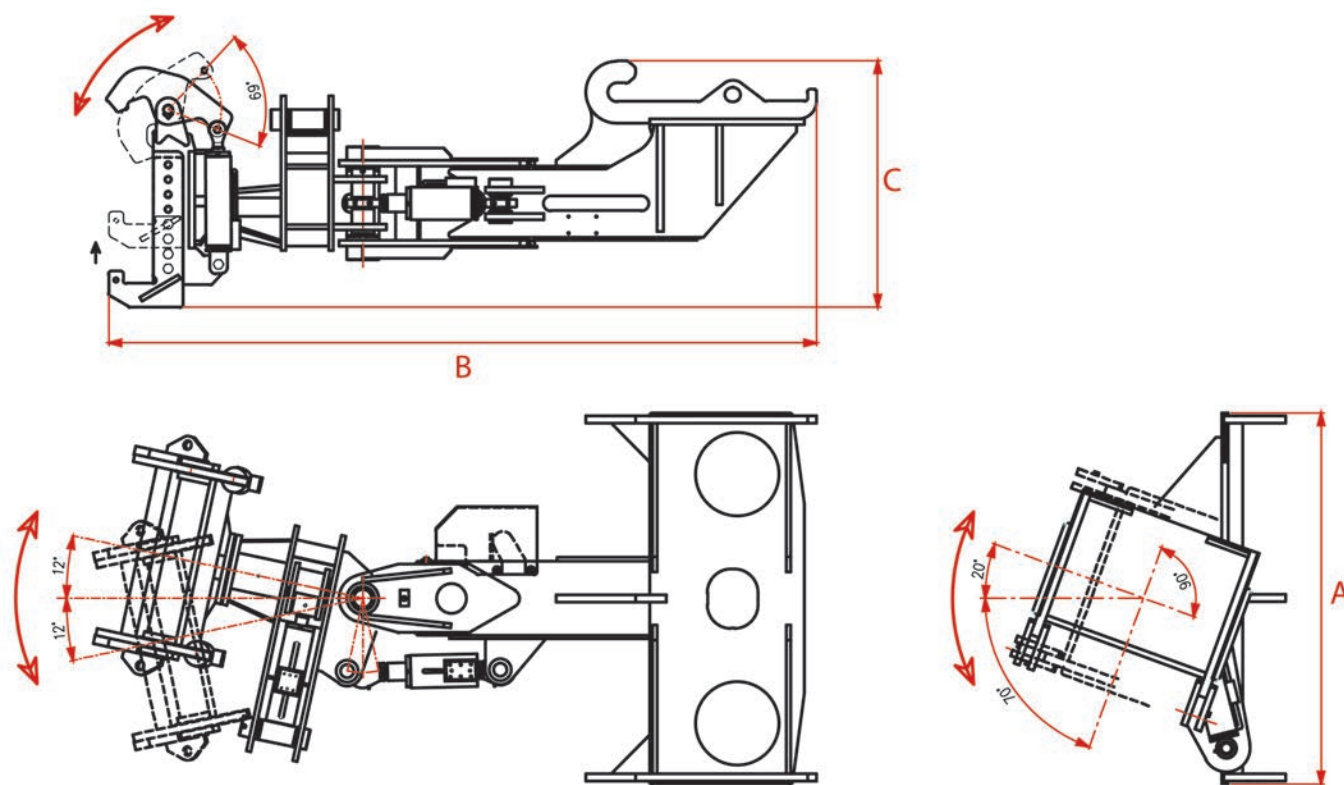

	Code					
BUD7009	TGN0022	1250 mm (49,2 in)	2385 mm (93,9 in)	830 mm (32,7 in)	3000 kg (6614 lb)	795 kg (1753 lb)
BUD7012	TGN0067	1250 mm (49,2 in)	2385 mm (93,9 in)	830 mm (32,7 in)	4000 kg (8818 lb)	795 kg (1753 lb)

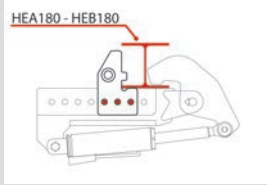
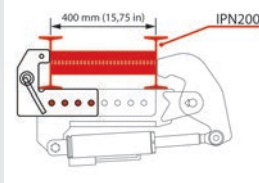
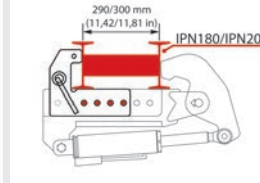
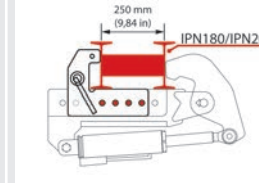
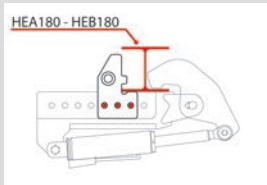
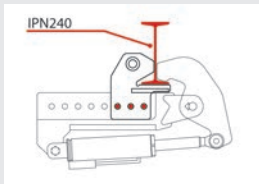
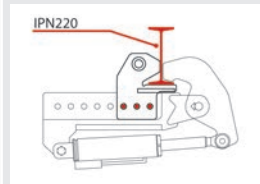
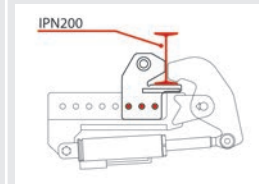
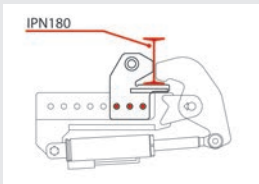
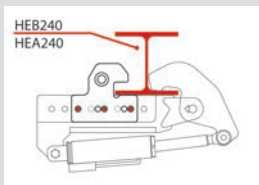
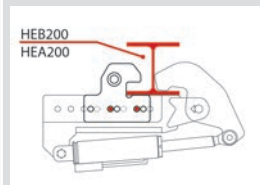
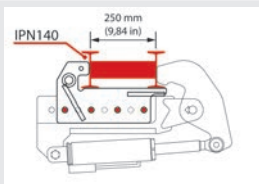
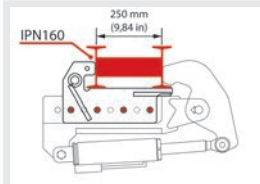
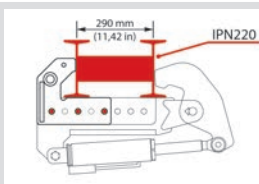
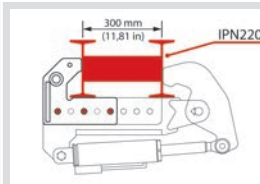
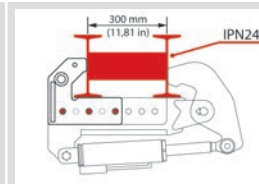
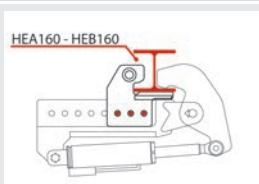
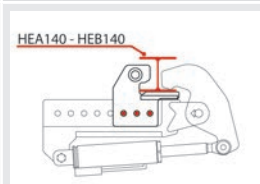
Tooth	Type of centring arc to handle			
BUD7006				
BUD7007				
BUD7011				
BUD7031				
BUD7032				
BUD7033				
BUD7034				
BUD7035				



## Gripper for pipe





Equipment designed to handle pipes of different lengths and sections. It is mainly used in the oil industry and environmental remediation.

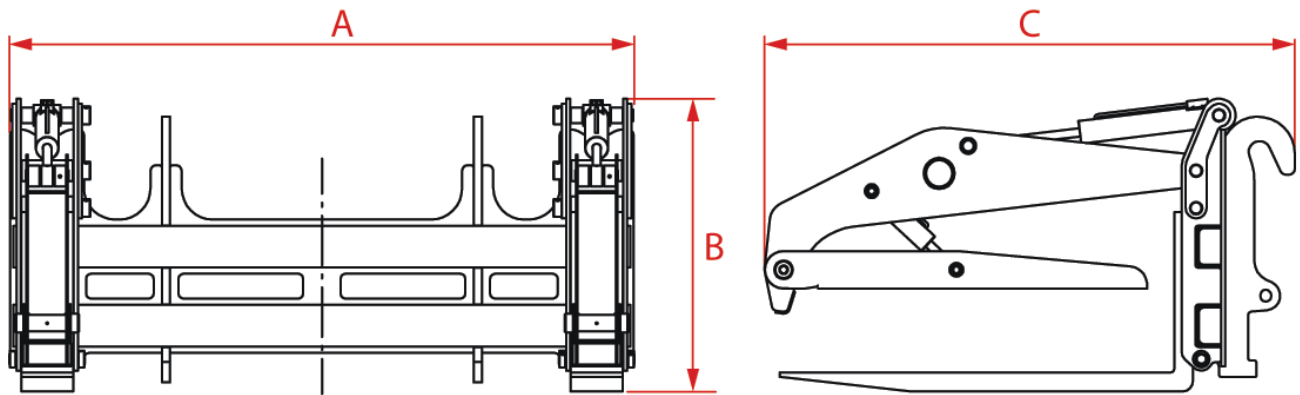

**Technical Data**



	Code	<b>A</b>	<b>B</b>	<b>C</b>		
BUD4052	TGN0065	2996 mm (118 in)	1406 mm (55,4 in)	2480 mm (97,6 in)	2370 kg (5225 lb)	8000 kg (17637 lb)
BUD4074	TGN0064	2996 mm (118 in)	1406 mm (55,4 in)	2480 mm (97,6 in)	2370 kg (5225 lb)	6000 kg (13228 lb)
BUD4077	TGN0074	3000 mm (118,1 in)	1390 mm (54,7 in)	3084 mm (121,4 in)	2480 kg (5467 lb)	6000 kg (13228 lb)
BUD4098	TGN0066	3000 mm (118,1 in)	1390 mm (54,7 in)	3084 mm (121,4 in)	2480 kg (5467 lb)	5000 kg (11023 lb)

## Special items

### Angled sweeper



The angled sweeper can be used for cleaning construction sites, roads, large court areas or thanks to the mechanical angle system as a snowplow in case of light snow.

**Technical Data**

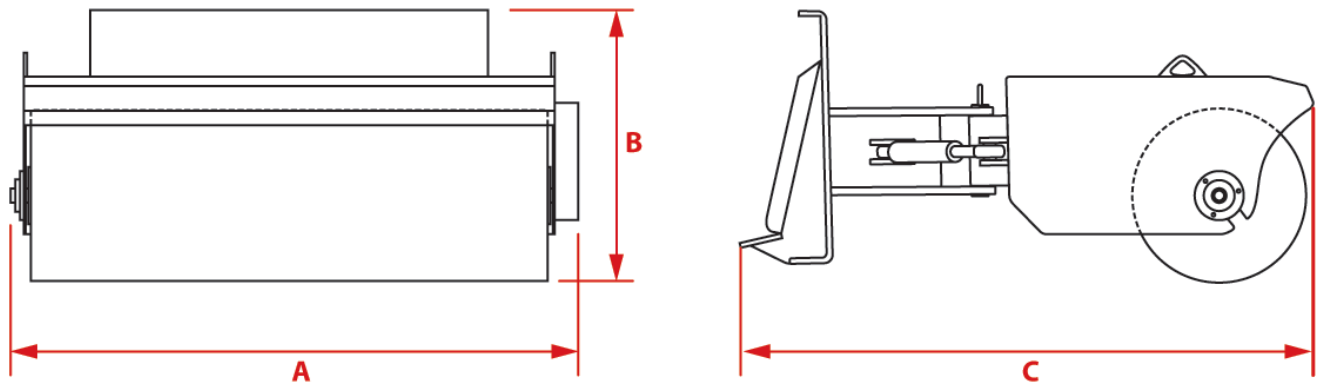

	Code	<b>A</b>	<b>B</b>	<b>C</b>	
BUD4064	-	1980 mm (78 in)	762 mm (30 in)	1272 mm (50,1 in)	370 kg (816 lb)
BUD4065	-	1980 mm (78 in)	762 mm (30 in)	1272 mm (50,1 in)	370 kg (816 lb)
BUD4072	TGN0046	2280 mm (89,8 in)	762 mm (30 in)	1272 mm (50,1 in)	410 kg (904 lb)
BUD4073	TGN0041	2280 mm (89,8 in)	762 mm (30 in)	1272 mm (50,1 in)	410 kg (904 lb)
BUD4091	TGN0029	2280 mm (89,8 in)	762 mm (30 in)	1272 mm (50,1 in)	420 kg (926 lb)

## Sweeper box with collection





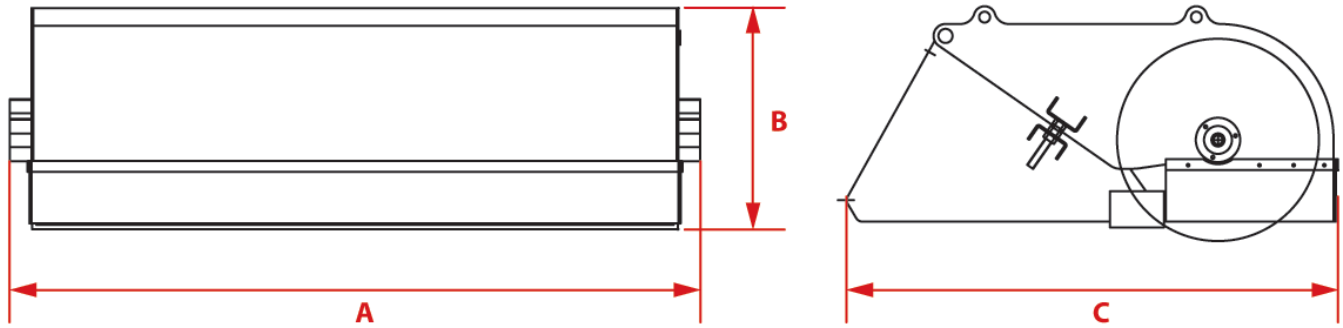

The sweeper box with collection can be used, thanks to its polypropylene brushes, for cleaning construction sites, roads, large areas of courts.

The use of the cutting edge makes it particularly suitable for scraping and collecting mud and debris from the ground.

**Technical Data**



	Code				
BUD4061	-	1920 mm (75,6 in)	612 mm (24,1 in)	1363 mm (53,7 in)	530 kg (1168 lb)
BUD4063	-	1920 mm (75,6 in)	612 mm (24,1 in)	1363 mm (53,7 in)	530 kg (1168 lb)
BUD4081	TGN0047	2220 mm (87,4 in)	612 mm (24,1 in)	1363 mm (53,7 in)	590 kg (1301 lb)
BUD4082	TGN0042	2220 mm (87,4 in)	612 mm (24,1 in)	1363 mm (53,7 in)	590 kg (1301 lb)
BUD4090	TGN0030	2220 mm (87,4 in)	612 mm (24,1 in)	1363 mm (53,7 in)	590 kg (1301 lb)

## Front shredder



This equipment stands out for its versatility of use, it is suitable for cutting grass, for cutting small shoots in vineyards or orchards and for cleaning the undergrowth.



**Technical Data**

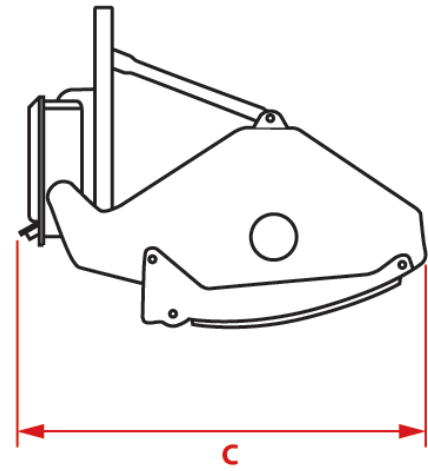
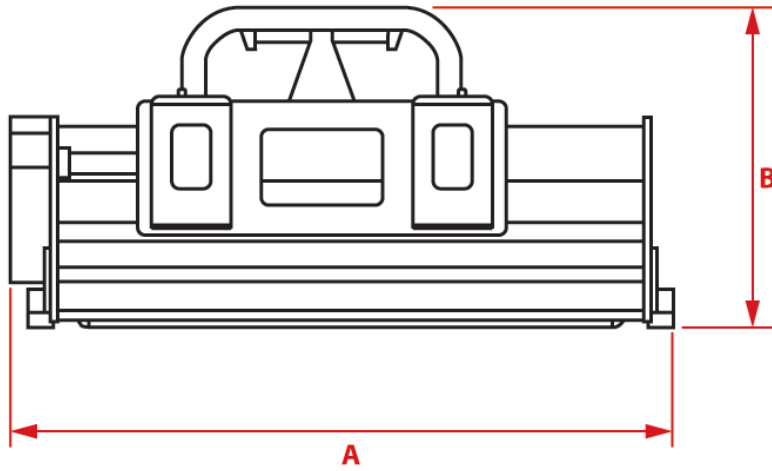

	Code	<b>A</b>	<b>B</b>	<b>C</b>	
BUD4066	-	1900 mm (74,8 in)	890 mm (35 in)	1080 mm (42,5 in)	460 kg (1014 lb)
BUD4067	-	1900 mm (74,8 in)	890 mm (35 in)	1080 mm (42,5 in)	460 kg (1014 lb)
BUD4085	TGN0052	2100 mm (82,7 in)	890 mm (35 in)	1080 mm (42,5 in)	510 kg (1124 lb)
BUD4086	TGN0053	2100 mm (82,7 in)	890 mm (35 in)	1080 mm (42,5 in)	510 kg (1124 lb)
BUD4094	TGN0033	2300 mm (90,6 in)	890 mm (35 in)	1080 mm (42,5 in)	560 kg (1235 lb)

## Two-stage turbine snow blower



This equipment has been designed for the removing large quantities of snow. The adoption of a hydraulic piston motor with torque limiter prevents the possibility of breakage due to accidental inlet of objects hidden in the snow. The notched ice-breaking propellers minimize wear caused by gravel and stones mixed with snow. The snow exit duct is equipped with mechanically adjustable flaps.

**Technical Data**

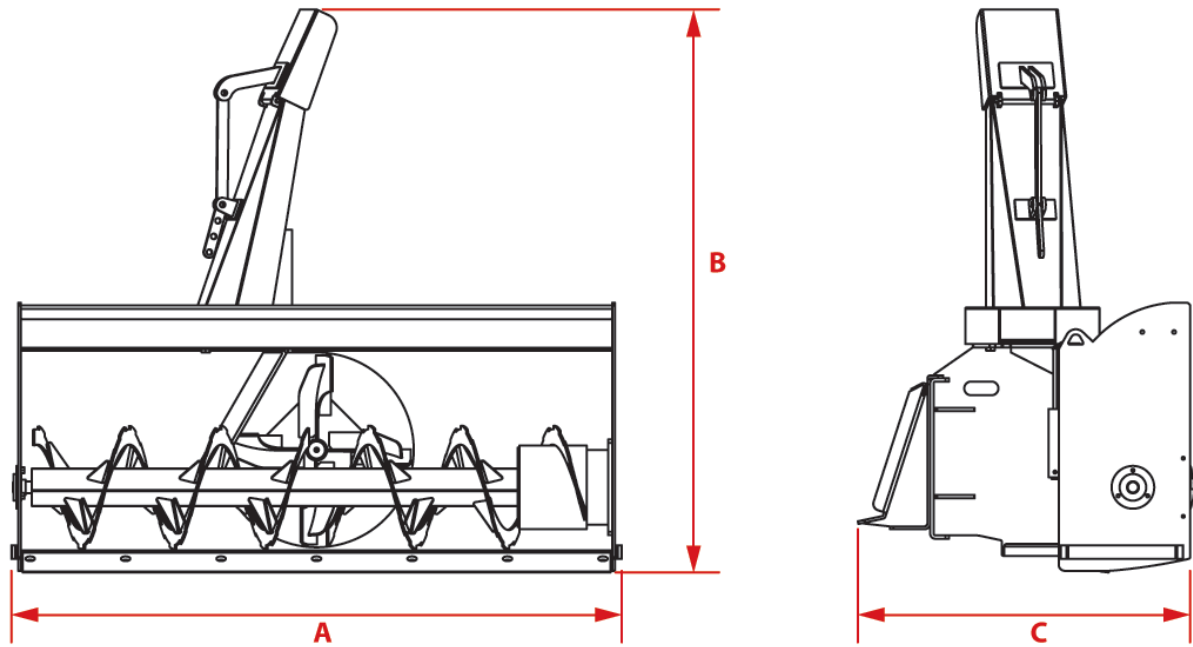

	Code	<b>A</b>	<b>B</b>	<b>C</b>	
BUD4068	TGN0048	2100 mm (82,7 in)	1650 mm (65 in)	990 mm (39 in)	890 kg (1962 lb)
BUD4069	TGN0049	2100 mm (82,7 in)	1650 mm (65 in)	990 mm (39 in)	890 kg (1962 lb)
BUD4092	TGN0031	2300 mm (90,6 in)	1650 mm (65 in)	990 mm (39 in)	950 kg (2094 lb)

## Lifting equipment

### Winches

#### Winch for forks holding plate







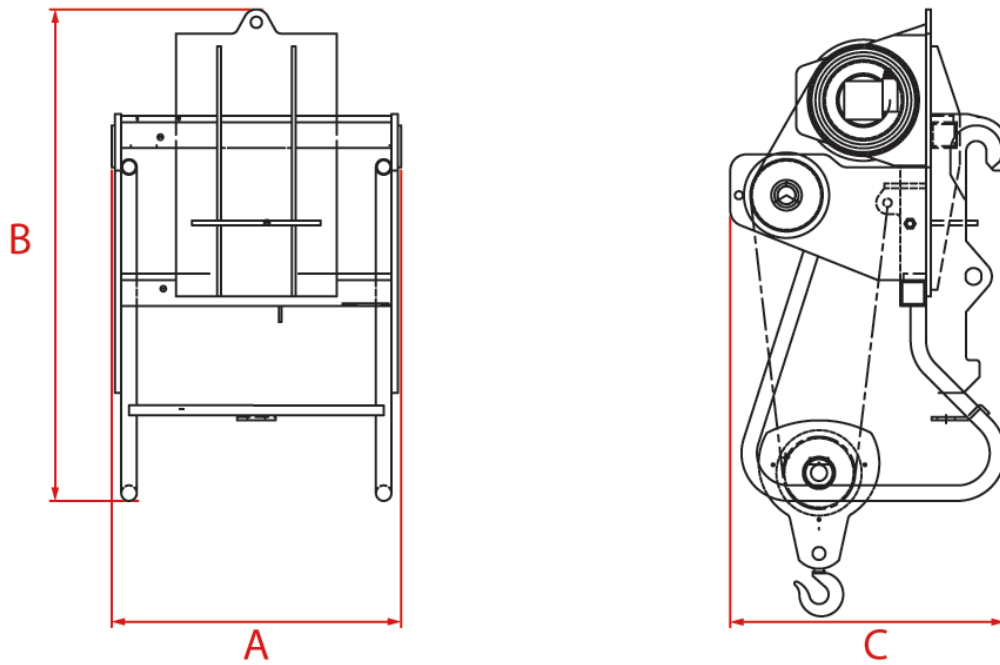

This equipment has been designed for lifting, transport and positioning suspended loads.

The block is equipped with a 360° swivel hook with locking tab.



**Technical Data**



	Code						
BUD4470	TSL0066	1302 mm (51,3 in)	1790 mm (70,5 in)	1927 mm (75,9 in)	Double, with rope guide	8000 kg (17637 lb)	1150 kg (2535 lb)
BUD4475	TSL0037	900 mm (35,4 in)	1460 mm (57,5 in)	960 mm (37,8 in)	Double, with rope guide	3000 kg (6614 lb)	410 kg (904 lb)
BUD4476	TSL0030	890 mm (35 in)	1540 mm (60,6 in)	1100 mm (43,3 in)	Double, with rope guide	4000 kg (8818 lb)	490 kg (1080 lb)
BUD4507	TSL0005	900 mm (35,4 in)	1460 mm (57,5 in)	960 mm (37,8 in)	Double, with rope guide	3000 kg (6614 lb)	410 kg (904 lb)
BUD4508	TSL0010	900 mm (35,4 in)	1525 mm (60 in)	855 mm (33,7 in)	Double, with rope guide	4000 kg (8818 lb)	490 kg (1080 lb)
BUD4515	TSL0015	900 mm (35,4 in)	1460 mm (57,5 in)	960 mm (37,8 in)	Double, with rope guide	3000 kg (6614 lb)	410 kg (904 lb)
BUD4516	TSL0016	900 mm (35,4 in)	1525 mm (60 in)	855 mm (33,7 in)	Double, with rope guide	4000 kg (8818 lb)	490 kg (1080 lb)
BUD4517	TSL0017	900 mm (35,4 in)	1525 mm (60 in)	845 mm (33,3 in)	Double, with rope guide	5000 kg (11023 lb)	490 kg (1080 lb)
BUD4540	TSL0055	900 mm (35,4 in)	1460 mm (57,5 in)	960 mm (37,8 in)	Double, with rope guide	3000 kg (6614 lb)	410 kg (904 lb)
BUD4541	TSL0056	900 mm (35,4 in)	1525 mm (60 in)	855 mm (33,7 in)	Double, with rope guide	4000 kg (8818 lb)	490 kg (1080 lb)
BUD4550	TSL0070	900 mm (35,4 in)	1525 mm (60 in)	845 mm (33,3 in)	Double, with rope guide	5000 kg (11023 lb)	490 kg (1080 lb)
BUD4562	TSL0057	900 mm (35,4 in)	1525 mm (60 in)	845 mm (33,3 in)	Double, with rope guide	5000 kg (11023 lb)	490 kg (1080 lb)



## Crane extension with winch



This equipment has been designed for lifting, transport and positioning suspended loads.



The jib crane structure helps to contain the weight of the equipment while maintaining excellent rigidity.

The block is equipped with a 360° swivel hook with locking tab.

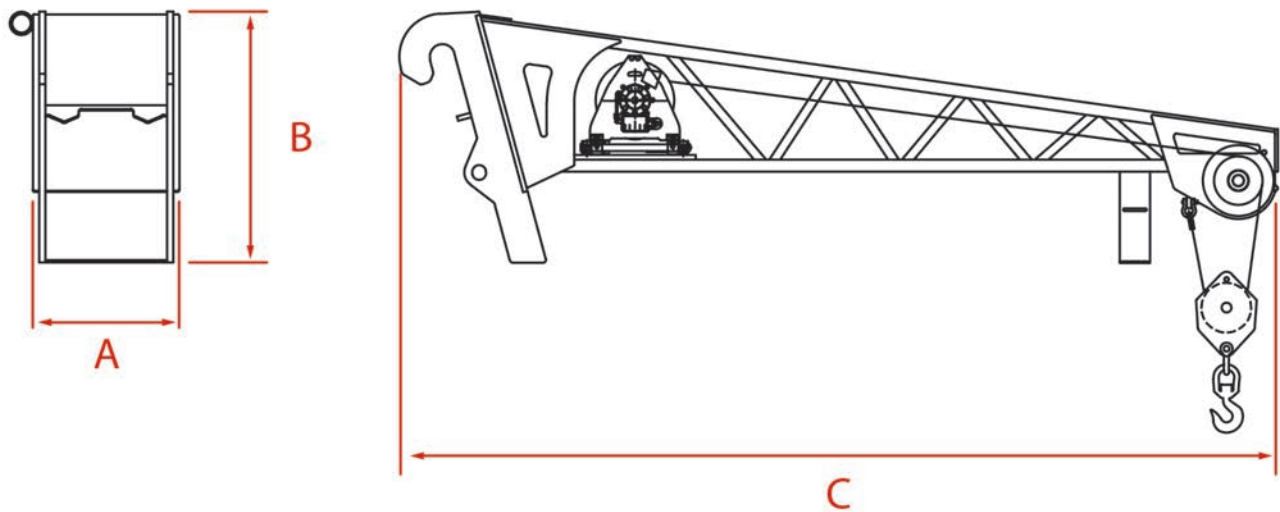

**Technical Data**



	Code	A	B	C			
BUD4548	TSL0071	550 mm (21,7 in)	1200 mm (47,2 in)	3000 mm (118,1 in)	Double	1500 kg (3307 lb)	430 kg (948 lb)
BUD4546	TSL0060	556 mm (21,9 in)	825 mm (32,5 in)	2850 mm (112,2 in)	Double	1200 kg (2646 lb)	350 kg (772 lb)
BUD4528	TSL0053	626 mm (24,6 in)	917 mm (36,1 in)	4975 mm (195,9 in)	Double	600 kg (1323 lb)	360 kg (794 lb)
BUD4532	TSL0051	556 mm (21,9 in)	825 mm (32,5 in)	2850 mm (112,2 in)	Double	1200 kg (2646 lb)	350 kg (772 lb)
BUD4529	TSL0049	480 mm (18,9 in)	825 mm (32,5 in)	1637 mm (64,4 in)	Double	2000 kg (4409 lb)	290 kg (639 lb)
BUD4520	TSL0041	776 mm (30,6 in)	825 mm (32,5 in)	2824 mm (111,2 in)	Double	1100 kg (2425 lb)	250 kg (551 lb)
BUD4518	TSL0039	776 mm (30,6 in)	825 mm (32,5 in)	1636 mm (64,4 in)	Double	1800 kg (3968 lb)	200 kg (441 lb)
BUD4454	TSL0035	720 mm (28,3 in)	1000 mm (39,4 in)	5050 mm (198,8 in)	Double	600 kg (1323 lb)	415 kg (915 lb)
BUD4452	TSL0033	556 mm (21,9 in)	825 mm (32,5 in)	2569 mm (101,1 in)	Double	1200 kg (2646 lb)	315 kg (694 lb)
BUD4474	TSL0031	640 mm (25,2 in)	900 mm (35,4 in)	1750 mm (68,9 in)	Double	2000 kg (4409 lb)	284 kg (626 lb)
BUD4560	TSL0013	556 mm (21,9 in)	825 mm (32,5 in)	2850 mm (112,2 in)	Double	1200 kg (2646 lb)	350 kg (772 lb)
BUD4509	TSL0011	640 mm (25,2 in)	900 mm (35,4 in)	1750 mm (68,9 in)	Double	2000 kg (4409 lb)	284 kg (626 lb)
BUD4505	TSL0008	626 mm (24,6 in)	917 mm (36,1 in)	4975 mm (195,9 in)	Double	600 kg (1323 lb)	360 kg (794 lb)



## Hooks

### Hook for forks holding plate



This equipment has been designed to handle suspended loads in total safety thanks to the sturdy structure and the 360° rotating hook with locking tab.



**Technical Data**

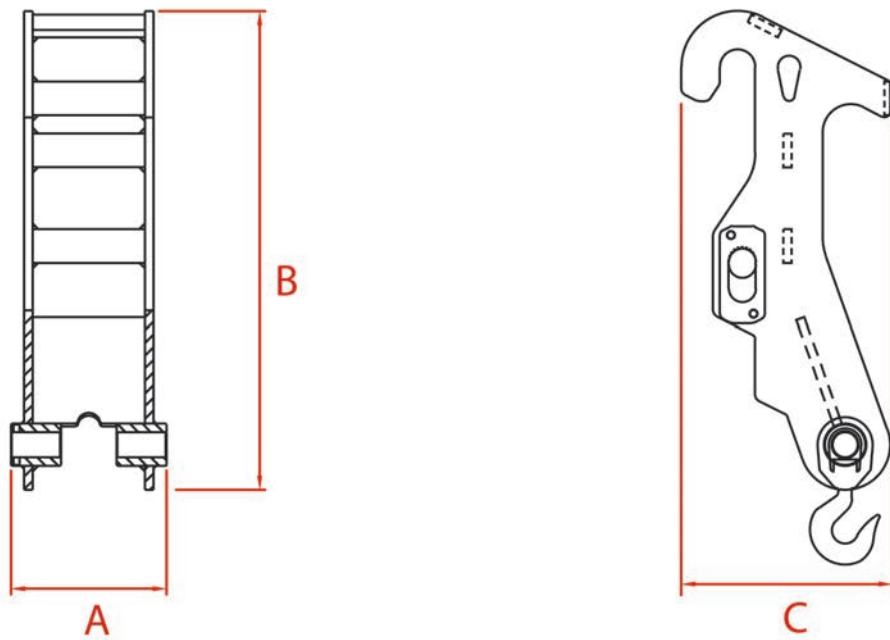

	Code	<b>A</b>	<b>B</b>	<b>C</b>	
BUB2448	TSL0007	277 mm (10,9 in)	850 mm (33,5 in)	376,5 mm (14,8 in)	60 kg (132 lb)
BUB2449	TSL0019	334 mm (13,1 in)	861,5 mm (33,9 in)	386,5 mm (15,2 in)	82 kg (181 lb)
BUB2631	TSL0045	1200 mm (47,2 in)	907 mm (35,7 in)	440 mm (17,3 in)	170 kg (375 lb)
BUB2632	TSL0046	1050 mm (41,3 in)	895 mm (35,2 in)	434 mm (17,1 in)	120 kg (265 lb)
BUB2516	TSL0067	1550 mm (61 in)	925 mm (36,4 in)	1020 mm (40,2 in)	575 kg (1268 lb)
BUB2517	TSL0068	1550 mm (61 in)	925 mm (36,4 in)	1020 mm (40,2 in)	575 kg (1268 lb)

## Crane extension with hook



This equipment has been designed for lifting, transport and positioning suspended loads.





The jib crane structure helps to contain the weight of the equipment while maintaining excellent rigidity.

The 360° swivel hook with locking tab and the standard load limiter ensure maximum safety.

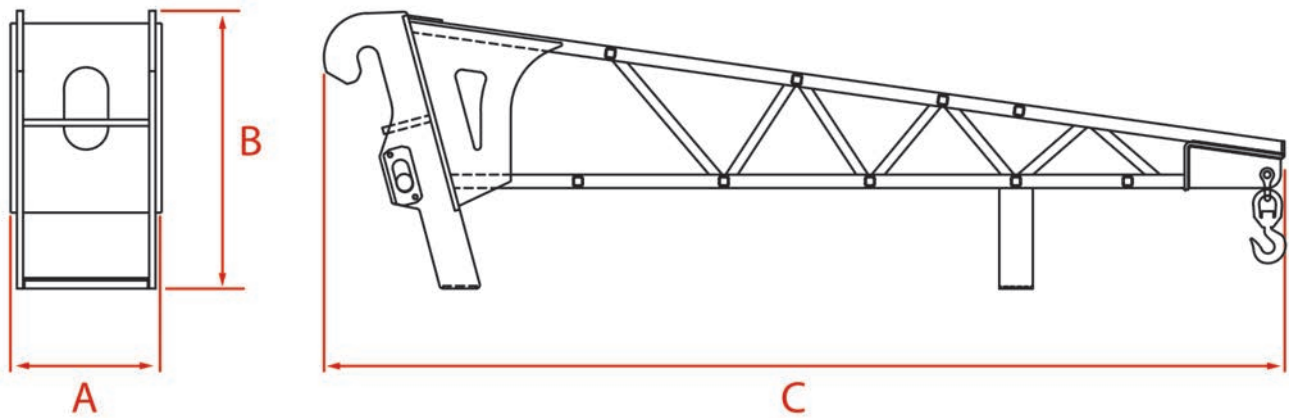

**Technical Data**



	Code					
BUD4502	TSL0002	650 mm (25,6 in)	870 mm (34,3 in)	1500 mm (59,1 in)	2000 kg (4409 lb)	160 kg (353 lb)
BUD4504	TSL0004	640 mm (25,2 in)	870 mm (34,3 in)	2850 mm (112,2 in)	1200 kg (2646 lb)	182 kg (401 lb)
BUD4506	TSL0009	730 mm (28,7 in)	950 mm (37,4 in)	5000 mm (196,9 in)	600 kg (1323 lb)	260 kg (573 lb)
BUD4510	TSL0012	480 mm (18,9 in)	825 mm (32,5 in)	1648 mm (64,9 in)	2000 kg (4409 lb)	150 kg (331 lb)
BUD4512	TSL0014	480 mm (18,9 in)	825 mm (32,5 in)	2848 mm (112,1 in)	1200 kg (2646 lb)	162 kg (357 lb)
BUD4482	TSL0032	640 mm (25,2 in)	850 mm (33,5 in)	1650 mm (65 in)	2000 kg (4409 lb)	142 kg (313 lb)
BUD4483	TSL0034	640 mm (25,2 in)	870 mm (34,3 in)	2850 mm (112,2 in)	1200 kg (2646 lb)	168 kg (370 lb)
BUD4484	TSL0036	730 mm (28,7 in)	950 mm (37,4 in)	5000 mm (196,9 in)	600 kg (1323 lb)	252 kg (556 lb)
BUD4519	TSL0040	700 mm (27,6 in)	864 mm (34 in)	1648 mm (64,9 in)	1800 kg (3968 lb)	162 kg (357 lb)
BUD4521	TSL0042	700 mm (27,6 in)	864 mm (34 in)	2821 mm (111,1 in)	1100 kg (2425 lb)	185 kg (408 lb)
BUD4487	TSL0050	480 mm (18,9 in)	825 mm (32,5 in)	1648 mm (64,9 in)	2000 kg (4409 lb)	170 kg (375 lb)
BUD4491	TSL0054	550 mm (21,7 in)	917 mm (36,1 in)	5000 mm (196,9 in)	600 kg (1323 lb)	245 kg (540 lb)
BUD4439	TSL0064	1550 mm (61 in)	1170 mm (46,1 in)	2965 mm (116,7 in)	4000 kg (8818 lb)	895 kg (1973 lb)
BUD4410	TSL0065	1150 mm (45,3 in)	1550 mm (61 in)	2965 mm (116,7 in)	6000 kg (13228 lb)	920 kg (2028 lb)

## Jib with hook





This equipment has been designed to handle heavy and cantilever loads.

Equipped with 360° rotating hook and load limiter, it is particularly suitable for the nursery sector.

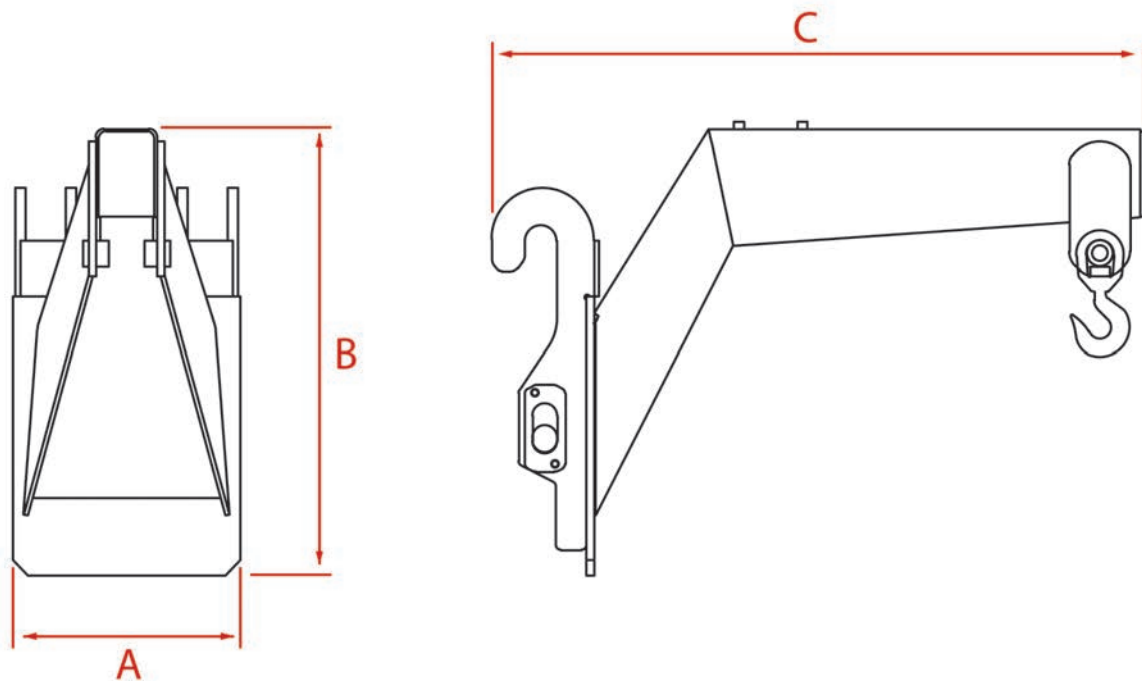

**Technical Data**



	Code	<b>A</b>	<b>B</b>	<b>C</b>		
BUD4496	TSL0006	460 mm (18,1 in)	700 mm (27,6 in)	1320 mm (52 in)	2500 kg (5512 lb)	162 kg (357 lb)
BUD4497	TSL0043	700 mm (27,6 in)	798 mm (31,4 in)	1301 mm (51,2 in)	2000 kg (4409 lb)	140 kg (309 lb)
BUD4498	TSL0018	450 mm (17,7 in)	930 mm (36,6 in)	1297 mm (51,1 in)	3000 kg (6614 lb)	160 kg (353 lb)
BUD4499	TSL0020	481 mm (18,9 in)	880 mm (34,6 in)	1697 mm (66,8 in)	3000 kg (6614 lb)	180 kg (397 lb)
BUD4479	TSL0038	460 mm (18,1 in)	700 mm (27,6 in)	1320 mm (52 in)	2500 kg (5512 lb)	162 kg (357 lb)
BUD4494	TSL0058	450 mm (17,7 in)	930 mm (36,6 in)	1297 mm (51,1 in)	3000 kg (6614 lb)	160 kg (353 lb)

## Baskets

### Front baskets

#### Front Basket



Front basket suitable to transport people and materials.





**Technical Data**

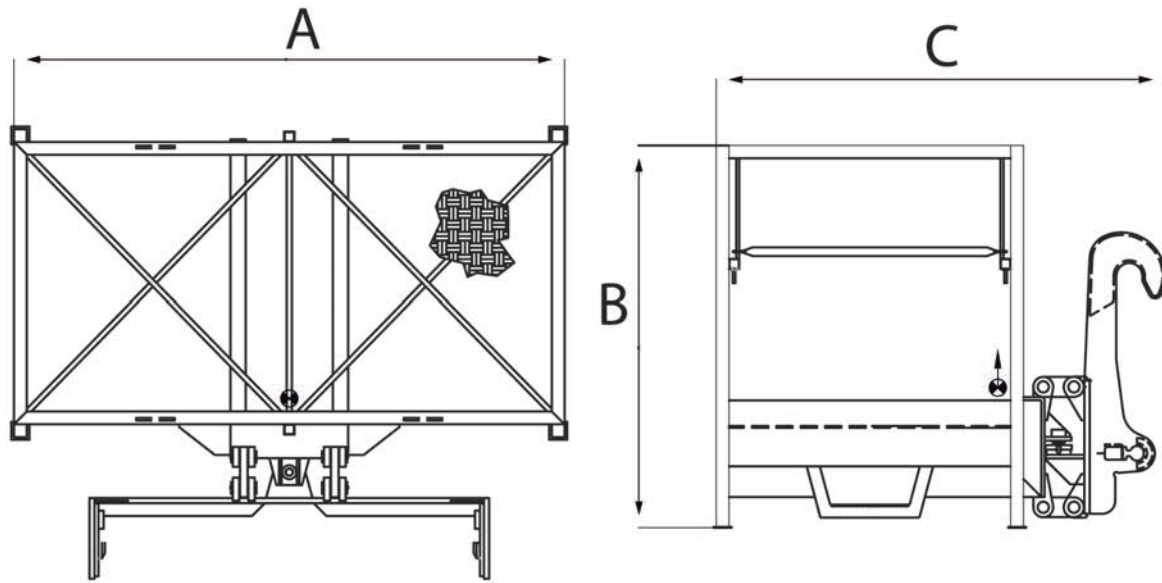

	Code	A	B	C	A	C	Person	Icon	Icon
BUD6416	TCS0022	2150 mm (84,6 in)	1490 mm (58,7 in)	1663 mm (65,5 in)	2150 mm (84,6 in)	1200 mm (47,2 in)	3	300 kg (661 lb)	405 kg (893 lb)
BUD6417	TCS0005	2150 mm (84,6 in)	1490 mm (58,7 in)	1663 mm (65,5 in)	2150 mm (84,6 in)	1200 mm (47,2 in)	3	300 kg (661 lb)	405 kg (893 lb)
BUD6445	TCS0001	1540 mm (60,6 in)	1313 mm (51,7 in)	995 mm (39,2 in)	1400 mm (55,1 in)	700 mm (27,6 in)	2	200 kg (441 lb)	110 kg (243 lb)
BUD6448	TCS0004	2150 mm (84,6 in)	1490 mm (58,7 in)	1663 mm (65,5 in)	2150 mm (84,6 in)	1200 mm (47,2 in)	3	300 kg (661 lb)	405 kg (893 lb)
BUD6465	TCS0003	2150 mm (84,6 in)	1490 mm (58,7 in)	1653 mm (65,1 in)	2150 mm (84,6 in)	1200 mm (47,2 in)	3	300 kg (661 lb)	405 kg (893 lb)
BUD6466	TCS0044	1540 mm (60,6 in)	1313 mm (51,7 in)	975 mm (38,4 in)	1400 mm (55,1 in)	700 mm (27,6 in)	2	200 kg (441 lb)	125 kg (276 lb)
BUD6469	TCS0050	2150 mm (84,6 in)	1490 mm (58,7 in)	1653 mm (65,1 in)	2150 mm (84,6 in)	1200 mm (47,2 in)	3	300 kg (661 lb)	405 kg (893 lb)
BUD6470	TCS0051	2150 mm (84,6 in)	1490 mm (58,7 in)	1653 mm (65,1 in)	2150 mm (84,6 in)	1200 mm (47,2 in)	3	300 kg (661 lb)	405 kg (893 lb)
BUD6485	TCS0017	2150 mm (84,6 in)	1490 mm (58,7 in)	1653 mm (65,1 in)	2150 mm (84,6 in)	1200 mm (47,2 in)	3	300 kg (661 lb)	405 kg (893 lb)
BUD6492	TCS0069	2150 mm (84,6 in)	1490 mm (58,7 in)	1653 mm (65,1 in)	2150 mm (84,6 in)	1200 mm (47,2 in)	3	300 kg (661 lb)	405 kg (893 lb)
BUD6494	TCS0066	2150 mm (84,6 in)	1490 mm (58,7 in)	1753 mm (69 in)	2150 mm (84,6 in)	1200 mm (47,2 in)	3	1000 kg (2205 lb)	537 kg (1184 lb)
BUD6495	TCS0071	2150 mm (84,6 in)	1490 mm (58,7 in)	1753 mm (69 in)	2150 mm (84,6 in)	1200 mm (47,2 in)	3	1000 kg (2205 lb)	537 kg (1184 lb)

## Extensible Front basket

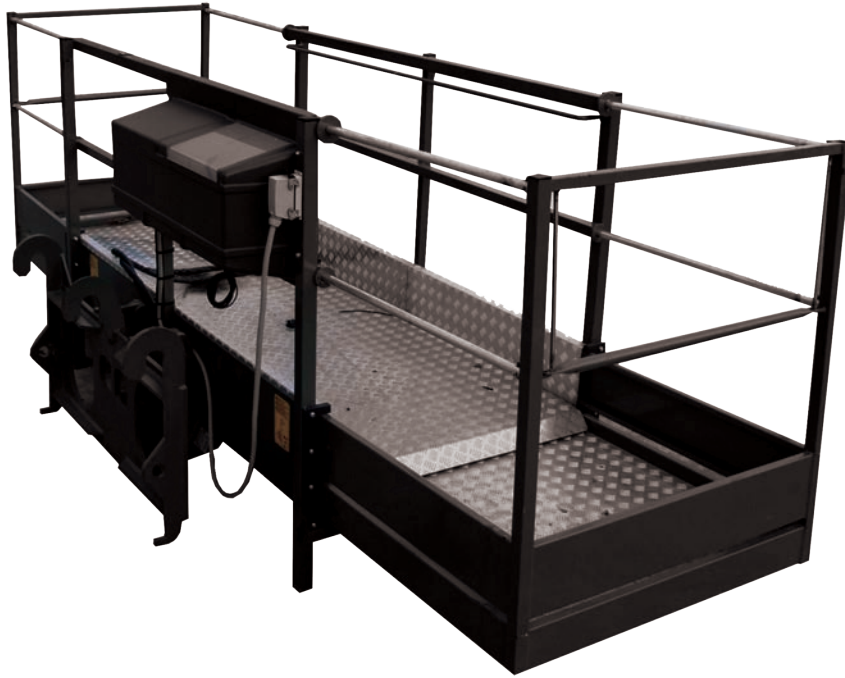

Extensible front basket hydraulically suitable for transporting people and materials.

**Technical Data**

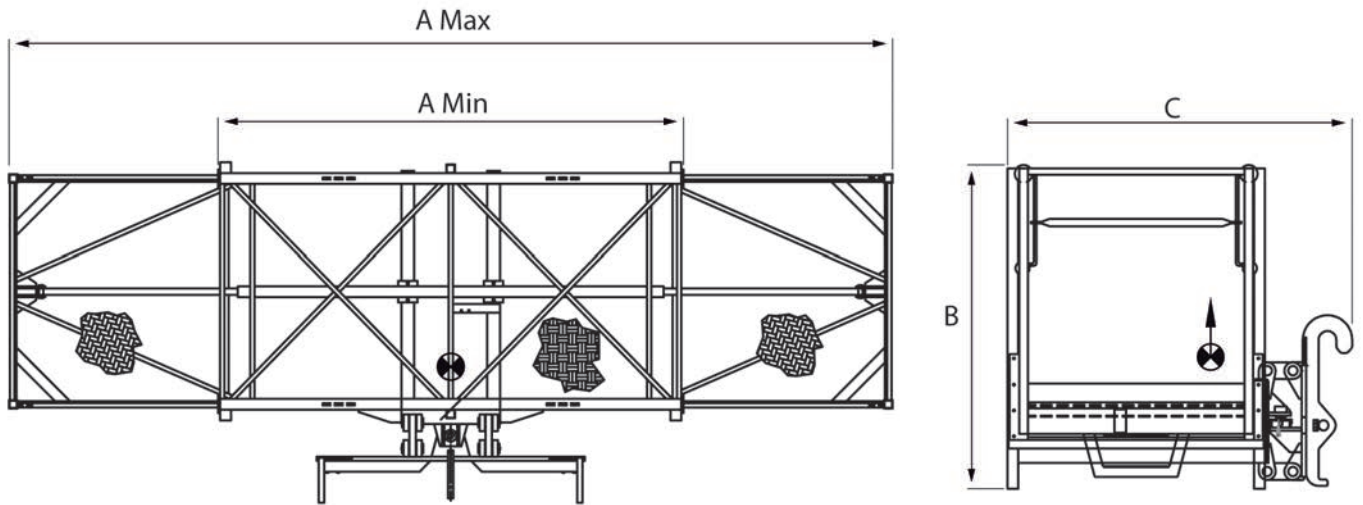

	Code	A	B	C	A	A <sup>max</sup>	C				
BUD6450	TCS0006	2410 mm (94,9 in)	1490 mm (58,7 in)	1587 mm (62,5 in)	2400 mm (94,5 in)	4120 mm (162,2 in)	1200 mm (47,2 in)	Hydraulic	3	300 kg (661 lb)	525 kg (1157 lb)
BUD6419	TCS0007	2410 mm (94,9 in)	1490 mm (58,7 in)	1587 mm (62,5 in)	2400 mm (94,5 in)	4120 mm (162,2 in)	1200 mm (47,2 in)	Hydraulic	3	300 kg (661 lb)	525 kg (1157 lb)
BUD6486	TCS0018	2410 mm (94,9 in)	1490 mm (58,7 in)	1607 mm (63,3 in)	2400 mm (94,5 in)	4120 mm (162,2 in)	1200 mm (47,2 in)	Hydraulic	3	300 kg (661 lb)	525 kg (1157 lb)
BUD6418	TCS0024	2410 mm (94,9 in)	1490 mm (58,7 in)	1587 mm (62,5 in)	2400 mm (94,5 in)	4120 mm (162,2 in)	1200 mm (47,2 in)	Hydraulic	3	300 kg (661 lb)	525 kg (1157 lb)
BUD6471	TCS0052	2410 mm (94,9 in)	1490 mm (58,7 in)	1607 mm (63,3 in)	2400 mm (94,5 in)	4120 mm (162,2 in)	1200 mm (47,2 in)	Hydraulic	3	300 kg (661 lb)	525 kg (1157 lb)
BUD6472	TCS0053	2410 mm (94,9 in)	1490 mm (58,7 in)	1607 mm (63,3 in)	2400 mm (94,5 in)	4120 mm (162,2 in)	1200 mm (47,2 in)	Hydraulic	3	300 kg (661 lb)	525 kg (1157 lb)

## Trilateral baskets







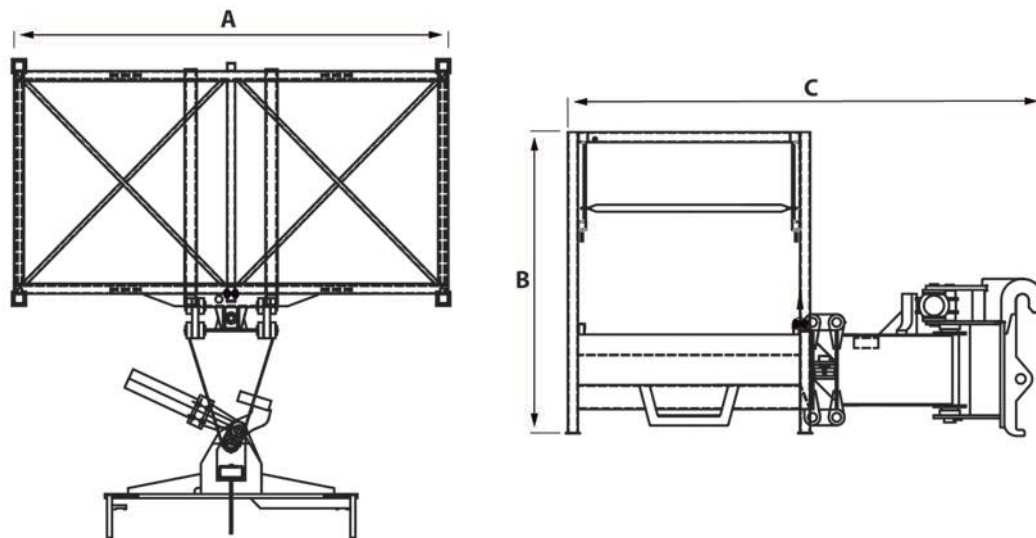

### Trilateral Basket

Trilateral hydraulic rotation basket suitable for transporting people and materials at height.



**Technical Data**



	Code								
BUD6452	TCS0008	2150 mm (84,6 in)	1490 mm (58,7 in)	2357 mm (92,8 in)	2150 mm (84,6 in)	1200 mm (47,2 in)	3	300 kg (661 lb)	550 kg (1213 lb)
BUD6453	-	2150 mm (84,6 in)	1490 mm (58,7 in)	2357 mm (92,8 in)	2150 mm (84,6 in)	1200 mm (47,2 in)	3	300 kg (661 lb)	550 kg (1213 lb)
BUD6487	TCS0019	2150 mm (84,6 in)	1490 mm (58,7 in)	2373 mm (93,4 in)	2150 mm (84,6 in)	1200 mm (47,2 in)	3	300 kg (661 lb)	550 kg (1213 lb)
BUD6422	TCS0026	2150 mm (84,6 in)	1490 mm (58,7 in)	2357 mm (92,8 in)	2150 mm (84,6 in)	1200 mm (47,2 in)	3	300 kg (661 lb)	550 kg (1213 lb)
BUD6420	TCS0047	2150 mm (84,6 in)	1490 mm (58,7 in)	2552 mm (100,5 in)	2150 mm (84,6 in)	1200 mm (47,2 in)	3	1000 kg (2205 lb)	700 kg (1543 lb)
BUD6421	TCS0048	2150 mm (84,6 in)	1490 mm (58,7 in)	2552 mm (100,5 in)	2150 mm (84,6 in)	1200 mm (47,2 in)	3	1000 kg (2205 lb)	700 kg (1543 lb)
BUD6473	TCS0054	2150 mm (84,6 in)	1490 mm (58,7 in)	1663 mm (65,5 in)	2150 mm (84,6 in)	1200 mm (47,2 in)	3	300 kg (661 lb)	405 kg (893 lb)
BUD6474	TCS0055	2150 mm (84,6 in)	1490 mm (58,7 in)	2373 mm (93,4 in)	2150 mm (84,6 in)	1200 mm (47,2 in)	3	300 kg (661 lb)	550 kg (1213 lb)
BUD6477	TCS0058	2150 mm (84,6 in)	1500 mm (59,1 in)	2552 mm (100,5 in)	2050 mm (80,7 in)	1000 mm (39,4 in)	3	800 kg (1764 lb)	685 kg (1510 lb)
BUD6478	TCS0059	2150 mm (84,6 in)	1500 mm (59,1 in)	2552 mm (100,5 in)	2050 mm (80,7 in)	1000 mm (39,4 in)	3	800 kg (1764 lb)	685 kg (1510 lb)
BUD6493	TCS0070	2150 mm (84,6 in)	1500 mm (59,1 in)	2552 mm (100,5 in)	2050 mm (80,7 in)	1000 mm (39,4 in)	3	800 kg (1764 lb)	685 kg (1510 lb)
BUD6440	TCS0075	2150 mm (84,6 in)	1500 mm (59,1 in)	2552 mm (100,5 in)	2400 mm (94,5 in)	1200 mm (47,2 in)	3	800 kg (1764 lb)	685 kg (1510 lb)
BUD6441	TCS0076	2150 mm (84,6 in)	1500 mm (59,1 in)	2552 mm (100,5 in)	2400 mm (94,5 in)	1200 mm (47,2 in)	3	800 kg (1764 lb)	685 kg (1510 lb)



## Extensible Trilateral basket



Trilateral hydraulic rotation basket, extensible by hydraulic cylinders, suitable for transporting people and materials at height.



**Technical Data**

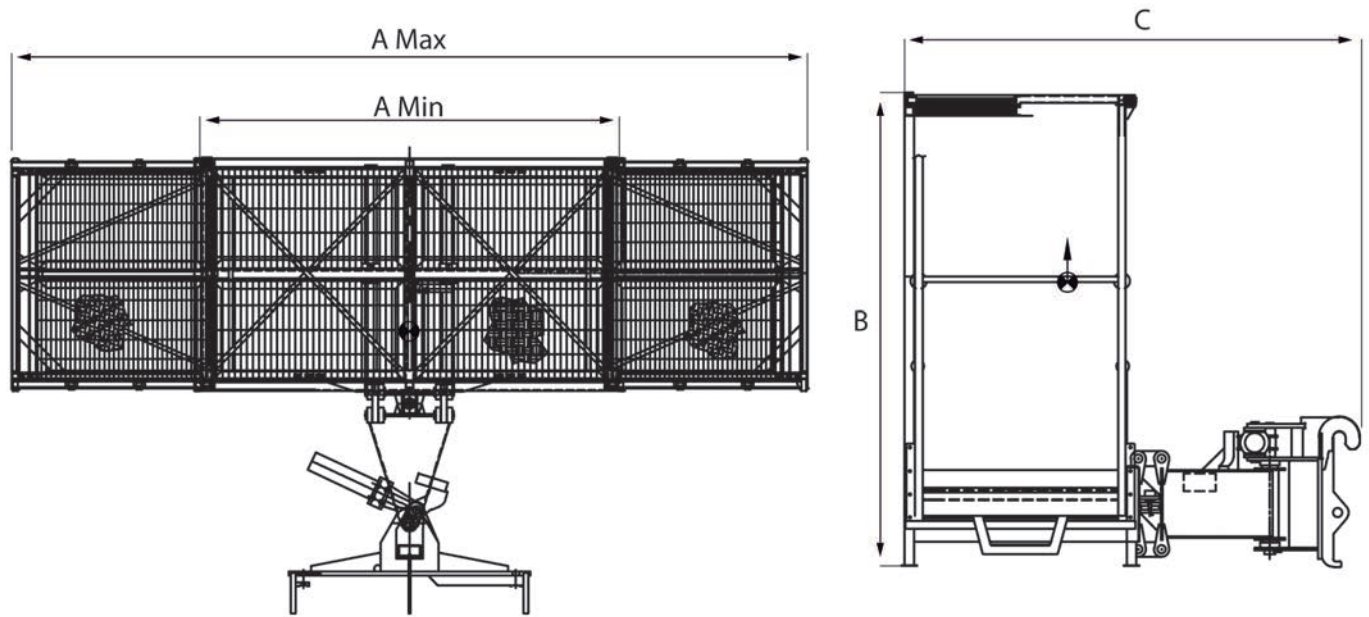

	Code	A	B	C	A	A <sup>max</sup>	C				
BUD6454	TCS0010	2410 mm (94,9 in)	1490 mm (58,7 in)	2354 mm (92,7 in)	2400 mm (94,5 in)	4120 mm (162,2 in)	1200 mm (47,2 in)	Hydraulic	3	300 kg (661 lb)	685 kg (1510 lb)
BUD6427	TCS0011	2410 mm (94,9 in)	1490 mm (58,7 in)	2354 mm (92,7 in)	2400 mm (94,5 in)	4120 mm (162,2 in)	1200 mm (47,2 in)	Hydraulic	3	300 kg (661 lb)	685 kg (1510 lb)
BUD6456	TCS0012	2400 mm (94,5 in)	1409 mm (55,5 in)	2550 mm (100,4 in)	2400 mm (94,5 in)	4116 mm (162 in)	1200 mm (47,2 in)	Hydraulic	3	800 kg (1764 lb)	985 kg (2172 lb)
BUD6429	TCS0013	2400 mm (94,5 in)	1409 mm (55,5 in)	2550 mm (100,4 in)	2400 mm (94,5 in)	4116 mm (162 in)	1200 mm (47,2 in)	Hydraulic	3	800 kg (1764 lb)	985 kg (2172 lb)
BUD6458	TCS0014	2470 mm (97,2 in)	1490 mm (58,7 in)	2552 mm (100,5 in)	2400 mm (94,5 in)	5800 mm (228,3 in)	1200 mm (47,2 in)	Hydraulic and Manual	3	300 kg (661 lb)	1165 kg (2568 lb)
BUD6425	TCS0015	2470 mm (97,2 in)	1490 mm (58,7 in)	2552 mm (100,5 in)	2400 mm (94,5 in)	5800 mm (228,3 in)	1200 mm (47,2 in)	Hydraulic and Manual	3	300 kg (661 lb)	1165 kg (2568 lb)
BUD6488	TCS0020	2410 mm (94,9 in)	1490 mm (58,7 in)	2376 mm (93,5 in)	2400 mm (94,5 in)	4120 mm (162,2 in)	1200 mm (47,2 in)	Hydraulic	3	300 kg (661 lb)	685 kg (1510 lb)



BUD6490	TCS0021	2400 mm (94,5 in)	1490 mm (58,7 in)	2572 mm (101,3 in)	2400 mm (94,5 in)	4116 mm (162 in)	1200 mm (47,2 in)	Hydraulic	3	800 kg (1764 lb)	985 kg (2172 lb)
BUD6426	TCS0028	2410 mm (94,9 in)	1490 mm (58,7 in)	2354 mm (92,7 in)	2400 mm (94,5 in)	4120 mm (162,2 in)	1200 mm (47,2 in)	Hydraulic	3	300 kg (661 lb)	685 kg (1510 lb)
BUD6428	TCS0030	2400 mm (94,5 in)	1409 mm (55,5 in)	2550 mm (100,4 in)	2400 mm (94,5 in)	4116 mm (162 in)	1200 mm (47,2 in)	Hydraulic	3	800 kg (1764 lb)	985 kg (2172 lb)
BUD6424	TCS0046	2470 mm (97,2 in)	1490 mm (58,7 in)	2552 mm (100,5 in)	2400 mm (94,5 in)	5800 mm (228,3 in)	1200 mm (47,2 in)	Hydraulic and Manual	3	300 kg (661 lb)	1165 kg (2568 lb)
BUD6475	TCS0056	2410 mm (94,9 in)	1490 mm (58,7 in)	2376 mm (93,5 in)	2400 mm (94,5 in)	4120 mm (162,2 in)	1200 mm (47,2 in)	Hydraulic	3	300 kg (661 lb)	685 kg (1510 lb)
BUD6476	TCS0057	2410 mm (94,9 in)	1490 mm (58,7 in)	2376 mm (93,5 in)	2400 mm (94,5 in)	4120 mm (162,2 in)	1200 mm (47,2 in)	Hydraulic	3	300 kg (661 lb)	685 kg (1510 lb)
BUD6479	TCS0060	2400 mm (94,5 in)	1490 mm (58,7 in)	2572 mm (101,3 in)	2400 mm (94,5 in)	4116 mm (162 in)	1200 mm (47,2 in)	Hydraulic	3	800 kg (1764 lb)	985 kg (2172 lb)
BUD6480	TCS0061	2400 mm (94,5 in)	1490 mm (58,7 in)	2572 mm (101,3 in)	2400 mm (94,5 in)	4116 mm (162 in)	1200 mm (47,2 in)	Hydraulic	3	800 kg (1764 lb)	985 kg (2172 lb)



## Trilateral basket for tunnels



Trilateral hydraulic rotation basket suitable for transporting people and materials at height equipped with a protective roof suitable for tunnel work.



**Technical Data**

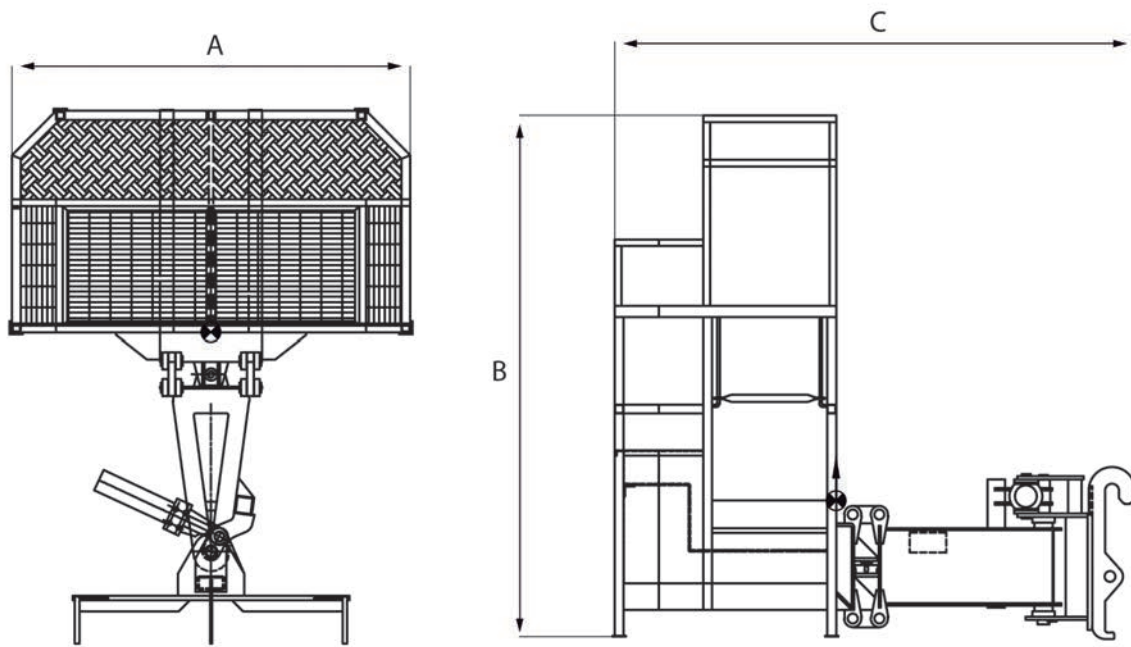

	Code	A	B	C	A	C			
BUD6446	TCS0032	2407 mm (94,8 in)	2445 mm (96,3 in)	2356 mm (92,8 in)	2400 mm (94,5 in)	1200 mm (47,2 in)	3	400 kg (882 lb)	1185 kg (2612 lb)
BUD6447	TCS0033	2407 mm (94,8 in)	2445 mm (96,3 in)	2356 mm (92,8 in)	2400 mm (94,5 in)	1200 mm (47,2 in)	3	400 kg (882 lb)	1185 kg (2612 lb)
BUD6430	TCS0034	1800 mm (70,9 in)	2350 mm (92,5 in)	2223 mm (87,5 in)	1800 mm (70,9 in)	1000 mm (39,4 in)	2	300 kg (661 lb)	775 kg (1709 lb)
BUD6431	TCS0035	1800 mm (70,9 in)	2350 mm (92,5 in)	2223 mm (87,5 in)	1800 mm (70,9 in)	1000 mm (39,4 in)	2	300 kg (661 lb)	775 kg (1709 lb)
BUD6432	TCS0036	1800 mm (70,9 in)	2350 mm (92,5 in)	2352 mm (92,6 in)	1800 mm (70,9 in)	1000 mm (39,4 in)	2	800 kg (1764 lb)	845 kg (1863 lb)
BUD6433	TCS0037	1800 mm (70,9 in)	2350 mm (92,5 in)	2352 mm (92,6 in)	1800 mm (70,9 in)	1000 mm (39,4 in)	2	800 kg (1764 lb)	845 kg (1863 lb)
BUD6481	TCS0062	1800 mm (70,9 in)	2350 mm (92,5 in)	2352 mm (92,6 in)	1800 mm (70,9 in)	1000 mm (39,4 in)	2	300 kg (661 lb)	760 kg (1676 lb)
BUD6482	TCS0063	1800 mm (70,9 in)	2350 mm (92,5 in)	2352 mm (92,6 in)	1800 mm (70,9 in)	1000 mm (39,4 in)	2	300 kg (661 lb)	760 kg (1676 lb)
BUD6483	TCS0064	1800 mm (70,9 in)	2350 mm (92,5 in)	2352 mm (92,6 in)	1800 mm (70,9 in)	1000 mm (39,4 in)	2	300 kg (661 lb)	760 kg (1676 lb)
BUD6484	TCS0065	1800 mm (70,9 in)	2350 mm (92,5 in)	2352 mm (92,6 in)	1800 mm (70,9 in)	1000 mm (39,4 in)	2	300 kg (661 lb)	760 kg (1676 lb)



## Volvo type basket

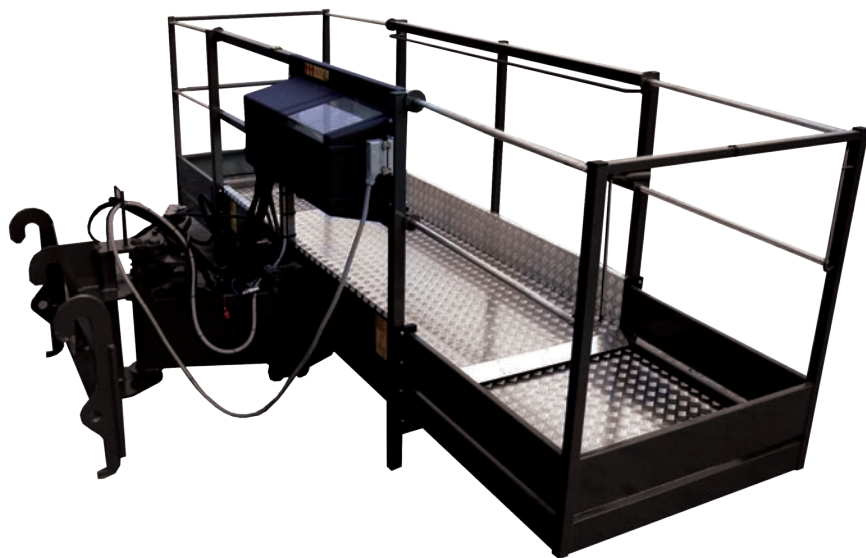

Trilateral hydraulic rotation basket, extensible by hydraulic cylinders, suitable for transporting people and materials at height.

The basket is equipped with a specific coupling which makes it compatible with Volvo brand vehicles.



**Technical Data**

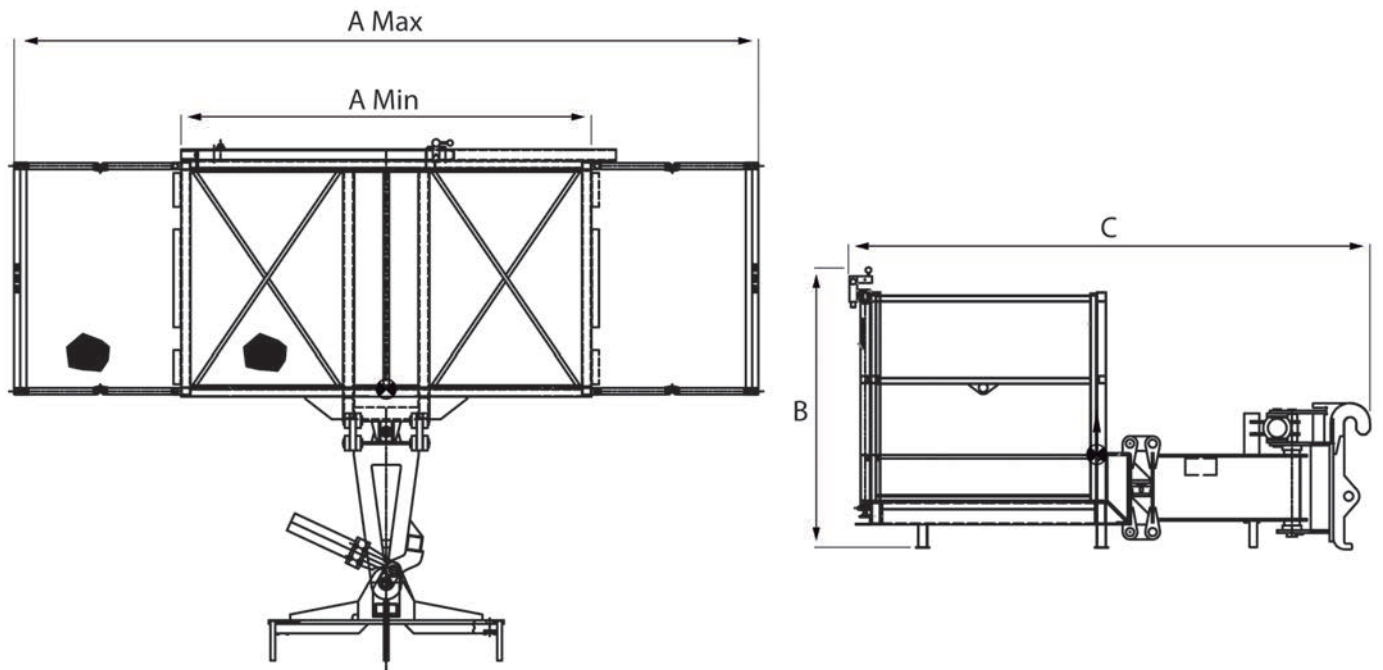

	Code	A	B	C	A	A <sup>max</sup>	C				
BUD6439	TCS0041	2410 mm (94,9 in)	1487 mm (58,5 in)	2341 mm (92,2 in)	2400 mm (94,5 in)	4120 mm (162,2 in)	1200 mm (47,2 in)	Hydraulic	3	300 kg (661 lb)	685 kg (1510 lb)
BUD6467	TCS0049	2410 mm (94,9 in)	1487 mm (58,5 in)	2341 mm (92,2 in)	2400 mm (94,5 in)	4120 mm (162,2 in)	1200 mm (47,2 in)	Hydraulic	3	300 kg (661 lb)	685 kg (1510 lb)

**Positive / Negative jib****Positive / Negative jib**

Jib equipped with basket for transporting people and materials.

The particularity of this accessory is that it allows the operator to get off under the vehicle walking surface.





**Technical Data**

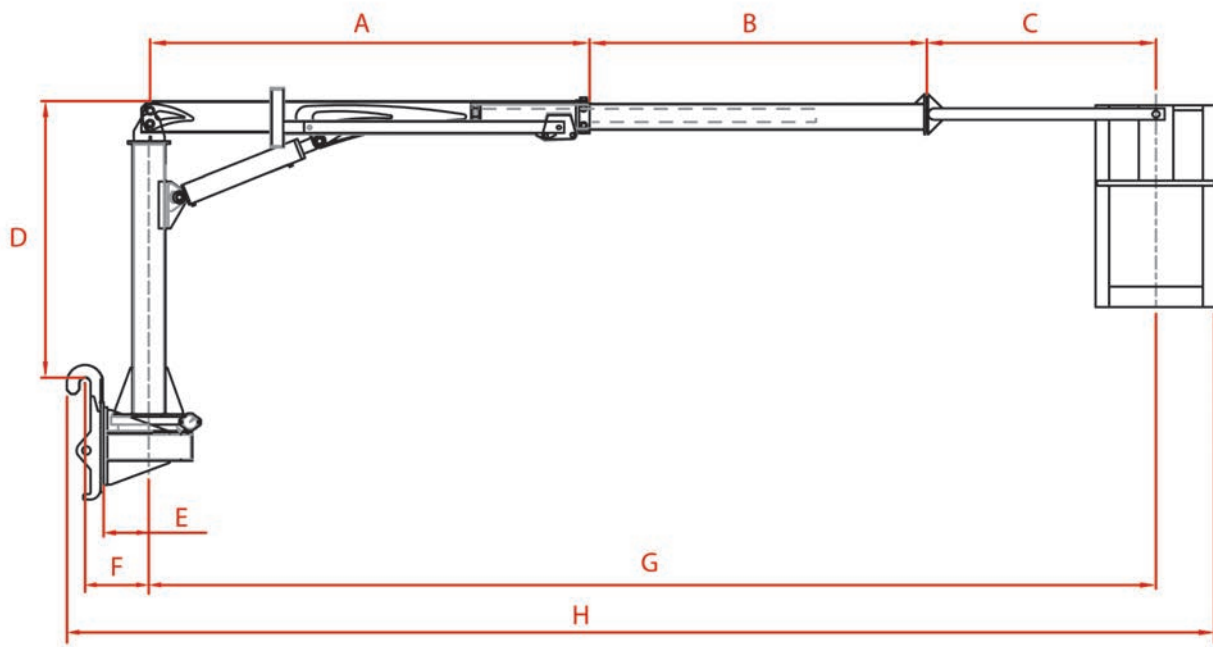

<b>A</b>	2540 mm (99.99 in)
<b>B</b>	2095 mm (82.48 in)
<b>C</b>	1323 mm (52.08 in)
<b>D</b>	1595 mm (62.79 in)
<b>E</b>	260 mm (10.23 in)
<b>F</b>	370 mm (14.56 in)
<b>G</b>	2965 mm (116.73 in)
<b>H</b>	7000 mm (275.59 in)
<b>Positive/negative Jib weight</b>	950 kg (2090 lb)
<b>Positive Jib weight</b>	750 kg (1650 lb)
<b>Maximum capacity- Maximum flow rate</b>	200 kg (440 lb)
<b>Persons</b>	2

## Baskets with lifting equipment

### Extensible Trilateral basket with winch









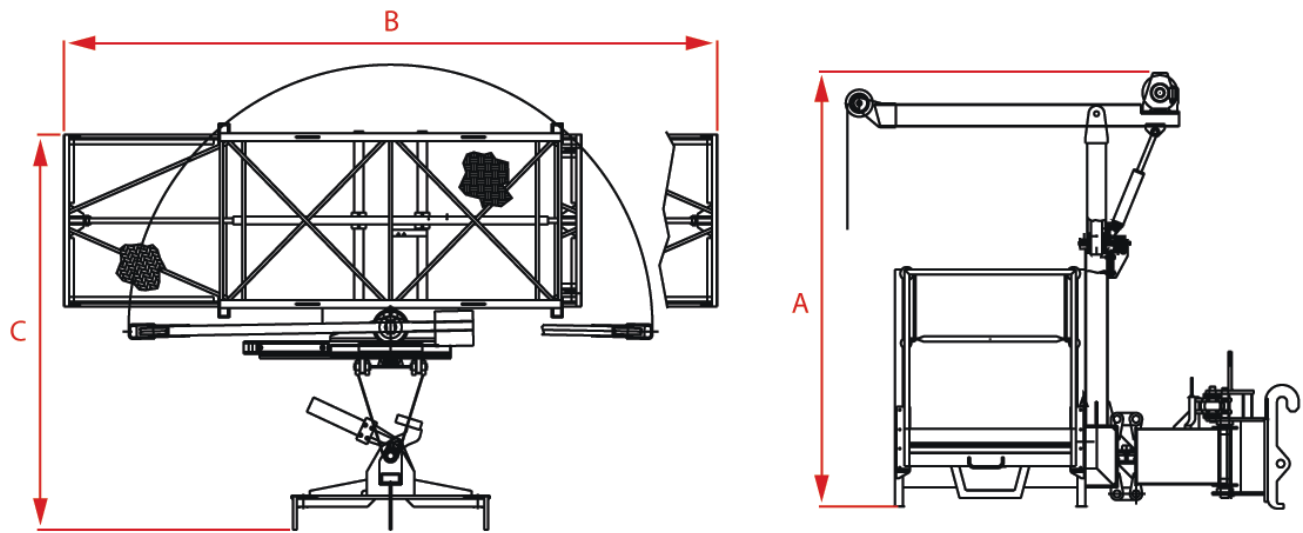



Extensible trilateral basket suitable for transporting people and materials. The basket is equipped with a jib with integrated winch that allows lifting material easily even while remaining at height.



**Technical Data**



	Code											
BUD6505	0	2406 mm (94,7 in)	2739 mm (107, 8 in)	2554 mm (100, 6 in)	2150 mm (84,6 in)	4116 mm (162 in)	1000 mm (39,4 in)	Hydraulic	3	Single	600 kg (1323 lb)	1215 kg (2679 lb)

## Baskets for landing at high altitude

### Extensible Trilateral basket with front opening



Trilateral hydraulic rotation basket, extensible by hydraulic cylinders, suitable for transporting people and materials at height.

The particular design allows opening a double swing door so that operators can get out.



**Technical Data**

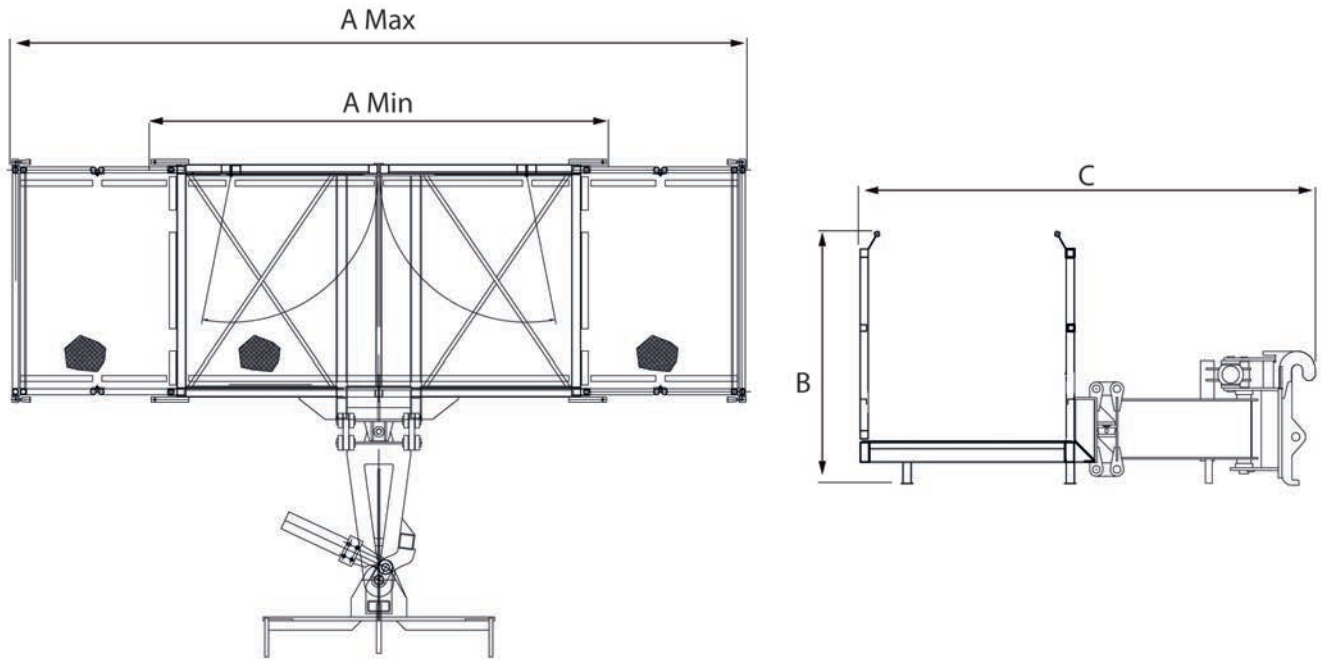

	Code	A	B	C	A	A <sup>max</sup>	C				
BUD6497	TCS0072	2180 mm (85,8 in)	1464 mm (57,6 in)	2653 mm (104,4 in)	2200 mm (86,6 in)	3960 mm (155,9 in)	1200 mm (47,2 in)	Manual	2	500 kg (1102 lb)	845 kg (1863 lb)
BUD6498	TCS0073	2180 mm (85,8 in)	1464 mm (57,6 in)	2653 mm (104,4 in)	2200 mm (86,6 in)	3960 mm (155,9 in)	1200 mm (47,2 in)	Manual	2	500 kg (1102 lb)	845 kg (1863 lb)
BUD6499	TCS0074	2180 mm (85,8 in)	1464 mm (57,6 in)	2653 mm (104,4 in)	2200 mm (86,6 in)	3960 mm (155,9 in)	1200 mm (47,2 in)	Manual	2	500 kg (1102 lb)	845 kg (1863 lb)
BUD6501	TCS0085	2180 mm (85,8 in)	1464 mm (57,6 in)	2653 mm (104,4 in)	2200 mm (86,6 in)	3960 mm (155,9 in)	1200 mm (47,2 in)	Manual	2	500 kg (1102 lb)	845 kg (1863 lb)

## Accessories

### Bucket

### Level indicator

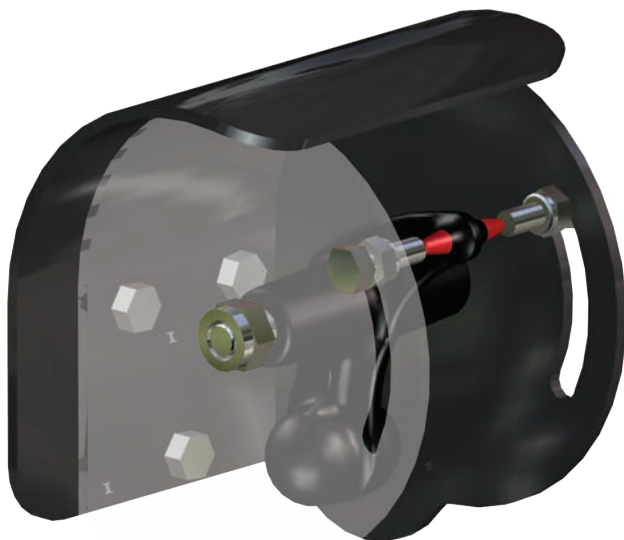

Optional equipment on all types of buckets and forks.



**Technical Data**

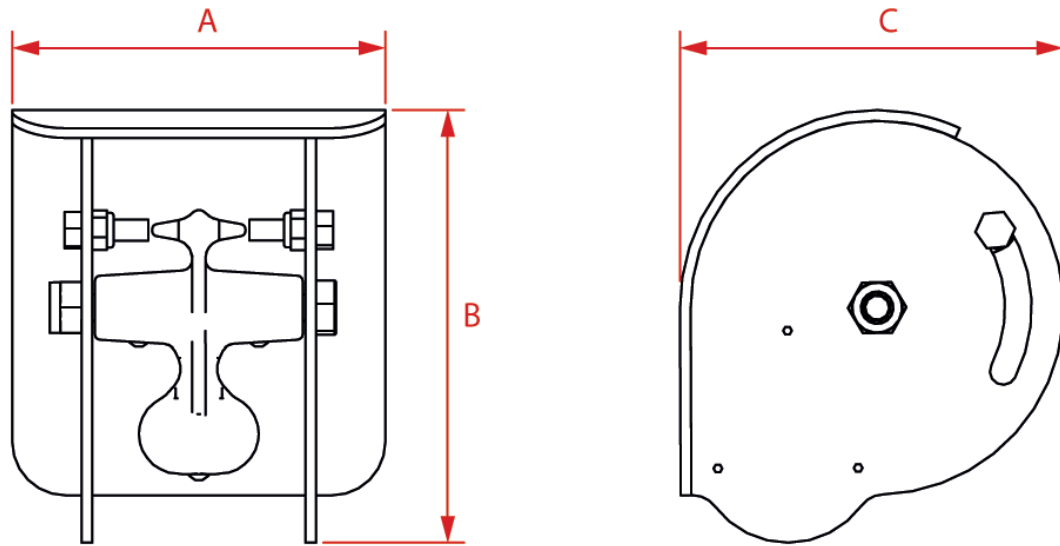

	Code	<b>A</b>	<b>B</b>	<b>C</b>	
DRE3511	TBN0132	140 mm (5,5 in)	162 mm (6,4 in)	165 mm (6,5 in)	2,6 kg (6 lb)





## Blade protector and/or teeth cover

Optional equipment on all types of buckets.

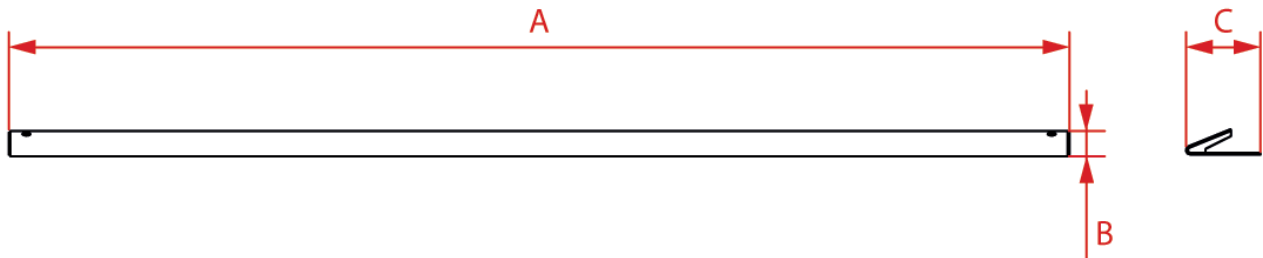

**Technical Data**



	Code				
ASMCM0000217-0G	TBN0131	1980 mm (78 in)	47 mm (1,9 in)	139 mm (5,5 in)	10,8 kg (24 lb)
ASMCM0000273-0G	TBN0230	2100 mm (82,7 in)	47 mm (1,9 in)	139 mm (5,5 in)	11,5 kg (25 lb)
ASMCM0000283-0G	TBN0231	1900 mm (74,8 in)	47 mm (1,9 in)	139 mm (5,5 in)	10,5 kg (23 lb)
ASMCM0000355-0G	TBN0235	1500 mm (59,1 in)	47 mm (1,9 in)	139 mm (5,5 in)	8,2 kg (18 lb)
ASMCM0000192-0G	TBN0144	2400 mm (94,5 in)	47 mm (1,9 in)	139 mm (5,5 in)	13,5 kg (30 lb)
ASMCM0000248-0G	TBN0143	2300 mm (90,6 in)	47 mm (1,9 in)	139 mm (5,5 in)	12,7 kg (28 lb)
ASMCM0000325-0G	TBN0234	2450 mm (96,5 in)	47 mm (1,9 in)	139 mm (5,5 in)	13,5 kg (30 lb)

## Full rear guard





### Optional equipment for:

- Bucket for light materials
- Excavating bucket with teeth
- Excavating bucket without teeth
- 4 in 1 bucket

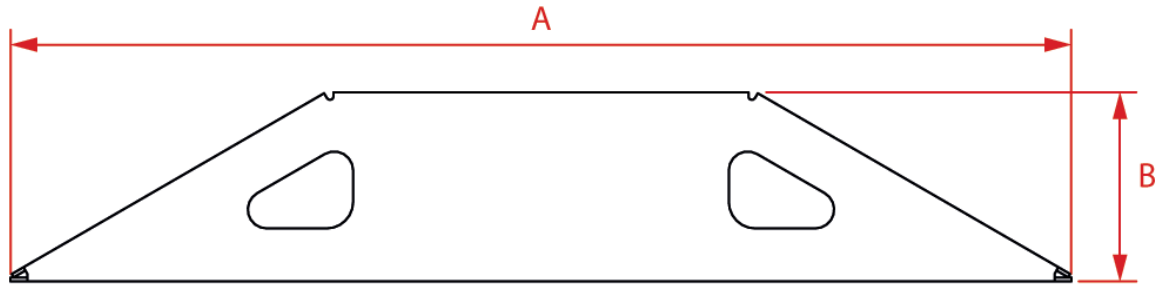
**Technical Data**



	Code	A 	B 	
ASMCM0000191-0G	TBN0129	1406 mm (55,4 in)	250 mm (9,8 in)	15 kg (33 lb)
ASMCM0000257-0G	TBN0141	1750 mm (68,9 in)	400 mm (15,7 in)	23,7 kg (52 lb)

## Split rear guard

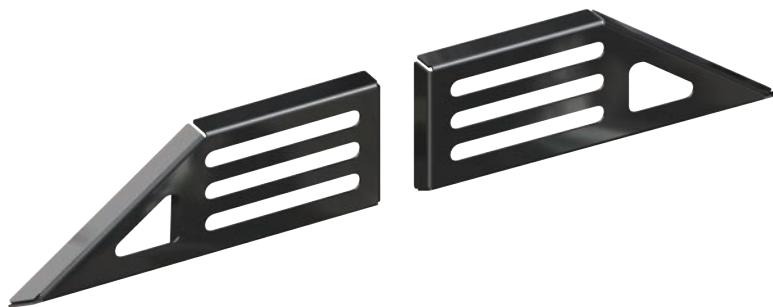



**Optional equipment for:**

- Bucket with grab
- Forks with grab

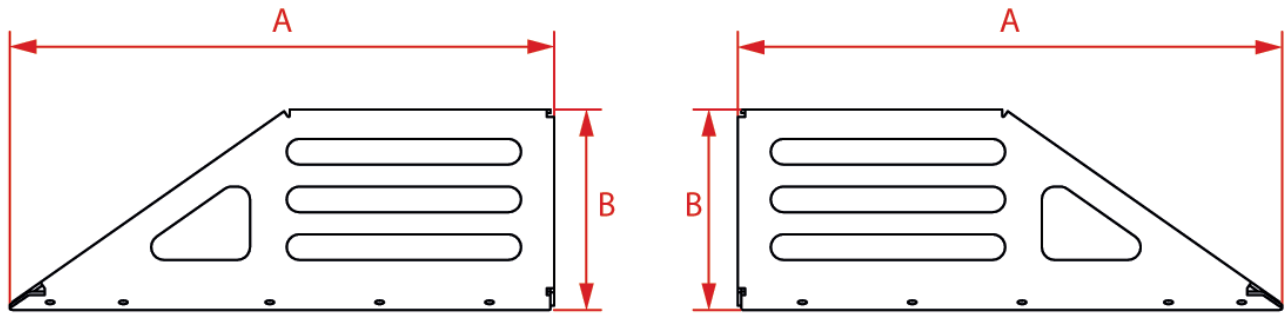

**Technical Data**



	Code	<b>A</b>	<b>B</b>	
ASMCM0000210-0G	TBN0130	743 mm (29,3 in)	273 mm (10,7 in)	7,5 kg (17 lb)
ASMCM0000211-0G	TBN0130	743 mm (29,3 in)	273 mm (10,7 in)	7,5 kg (17 lb)
ASMCM0000258-0G	TBN0142	743 mm (29,3 in)	423 mm (16,7 in)	8,7 kg (19 lb)
ASMCM0000259-0G	TBN0142	743 mm (29,3 in)	423 mm (16,7 in)	8,7 kg (19 lb)

# Detailed table of contents

BUD1166	61	TBN0129	121	TBN0182	14	TBN0227	43
BUD1170	59	TBN0130	123	TBN0183	14	TBN0228	43
BUD1171	59	TBN0131	119	TBN0184	14	TBN0229	43
BUD1172	61	TBN0132	117	TBN0185	14	TBN0230	119
BUD1173	63	TBN0133	40	TBN0186	14	TBN0231	119
BUD1174	63	TBN0134	40	TBN0187	14	TBN0234	119
BUD2728	49	TBN0135	40	TBN0188	14	TBN0235	119
BUD4061	81	TBN0137	46	TBN0189	14	TBN0246	49
BUD4063	81	TBN0138	46	TBN0190	14	TBN0254	49
BUD4064	79	TBN0139	43	TBN0191	11	TBN0259	49
BUD4065	79	TBN0140	43	TBN0192	11	TCS0001	97
BUD4066	83	TBN0141	121	TBN0193	11	TCS0002	17
BUD4067	83	TBN0142	123	TBN0194	11	TCS0003	97
BUD4564	71	TBN0143	119	TBN0195	8	TCS0004	97
BUD6453	101	TBN0144	119	TBN0196	8	TCS0005	97
BUD6505	113	TBN0148	11	TBN0197	8	TCS0006	99
TBN0034	51	TBN0150	14	TBN0198	8	TCS0007	99
TBN0035	51	TBN0151	14	TBN0199	8	TCS0008	101
TBN0051	51	TBN0152	14	TBN0200	8	TCS0010	104
TBN0066	51	TBN0153	14	TBN0201	8	TCS0011	104
TBN0077	51	TBN0156	14	TBN0202	8	TCS0012	104
TBN0079	51	TBN0157	14	TBN0203	8	TCS0013	104
TBN0088	51	TBN0158	14	TBN0204	8	TCS0014	104
TBN0089	51	TBN0159	14	TBN0205	8	TCS0015	104
TBN0102	11	TBN0161	11	TBN0206	8	TCS0016	17
TBN0105	11	TBN0162	11	TBN0207	8	TCS0017	97
TBN0106	8	TBN0163	11	TBN0208	8	TCS0018	99
TBN0107	8	TBN0164	11	TBN0209	8	TCS0019	101
TBN0108	8	TBN0165	8	TBN0210	8	TCS0020	104
TBN0109	8	TBN0166	8	TBN0211	8	TCS0021	104
TBN0113	46	TBN0167	8	TBN0212	8	TCS0022	97
TBN0114	8	TBN0168	8	TBN0213	40	TCS0024	99
TBN0115	14	TBN0169	8	TBN0214	40	TCS0026	101
TBN0116	14	TBN0170	8	TBN0215	40	TCS0028	104
TBN0117	11	TBN0171	8	TBN0216	40	TCS0030	104
TBN0118	40	TBN0172	8	TBN0217	40	TCS0032	107
TBN0119	40	TBN0173	40	TBN0218	46	TCS0033	107
TBN0120	40	TBN0174	40	TBN0219	46	TCS0034	107
TBN0121	11	TBN0175	40	TBN0220	46	TCS0035	107
TBN0122	14	TBN0176	40	TBN0221	46	TCS0036	107
TBN0123	14	TBN0177	46	TBN0222	46	TCS0037	107
TBN0124	8	TBN0178	46	TBN0223	46	TCS0041	109
TBN0126	46	TBN0179	46	TBN0224	43	TCS0044	97
TBN0127	8	TBN0180	46	TBN0225	43	TCS0045	17
TBN0128	8	TBN0181	14	TBN0226	43	TCS0046	104

TCS0047	<b>101</b>	TFR0004	<b>26</b>	TGN0046	<b>79</b>	TSL0042	<b>93</b>
TCS0048	<b>101</b>	TFR0006	<b>26</b>	TGN0047	<b>81</b>	TSL0043	<b>95</b>
TCS0049	<b>109</b>	TFR0007	<b>26</b>	TGN0048	<b>85</b>	TSL0045	<b>91</b>
TCS0050	<b>97</b>	TFR0008	<b>26</b>	TGN0049	<b>85</b>	TSL0046	<b>91</b>
TCS0051	<b>97</b>	TFR0010	<b>26</b>	TGN0052	<b>83</b>	TSL0049	<b>89</b>
TCS0052	<b>99</b>	TFR0018	<b>26</b>	TGN0053	<b>83</b>	TSL0050	<b>93</b>
TCS0053	<b>99</b>	TFR0021	<b>26</b>	TGN0057	<b>73</b>	TSL0051	<b>89</b>
TCS0054	<b>101</b>	TFR0022	<b>26</b>	TGN0063	<b>31</b>	TSL0053	<b>89</b>
TCS0055	<b>101</b>	TFR0023	<b>26</b>	TGN0064	<b>77</b>	TSL0054	<b>93</b>
TCS0056	<b>104</b>	TFR0024	<b>26</b>	TGN0065	<b>77</b>	TSL0055	<b>87</b>
TCS0057	<b>104</b>	TFR0025	<b>26</b>	TGN0066	<b>77</b>	TSL0056	<b>87</b>
TCS0058	<b>101</b>	TFR0027	<b>26</b>	TGN0067	<b>75</b>	TSL0057	<b>87</b>
TCS0059	<b>101</b>	TGN0003	<b>65</b>	TGN0068	<b>67</b>	TSL0058	<b>95</b>
TCS0060	<b>104</b>	TGN0007	<b>29</b>	TGN0069	<b>71</b>	TSL0060	<b>89</b>
TCS0061	<b>104</b>	TGN0008	<b>31</b>	TGN0072	<b>61</b>	TSL0064	<b>93</b>
TCS0062	<b>107</b>	TGN0009	<b>55</b>	TGN0074	<b>77</b>	TSL0065	<b>93</b>
TCS0063	<b>107</b>	TGN0010	<b>57</b>	TSL0002	<b>93</b>	TSL0066	<b>87</b>
TCS0064	<b>107</b>	TGN0012	<b>53</b>	TSL0004	<b>93</b>	TSL0067	<b>91</b>
TCS0065	<b>107</b>	TGN0013	<b>57</b>	TSL0005	<b>87</b>	TSL0068	<b>91</b>
TCS0066	<b>97</b>	TGN0015	<b>53</b>	TSL0006	<b>95</b>	TSL0070	<b>87</b>
TCS0067	<b>17</b>	TGN0016	<b>69</b>	TSL0007	<b>91</b>	TSL0071	<b>89</b>
TCS0069	<b>97</b>	TGN0017	<b>65</b>	TSL0008	<b>89</b>		
TCS0070	<b>101</b>	TGN0018	<b>29</b>	TSL0009	<b>93</b>		
TCS0071	<b>97</b>	TGN0019	<b>31</b>	TSL0010	<b>87</b>		
TCS0072	<b>115</b>	TGN0020	<b>55</b>	TSL0011	<b>89</b>		
TCS0073	<b>115</b>	TGN0021	<b>57</b>	TSL0012	<b>93</b>		
TCS0074	<b>115</b>	TGN0022	<b>75</b>	TSL0013	<b>89</b>		
TCS0075	<b>101</b>	TGN0023	<b>73</b>	TSL0014	<b>93</b>		
TCS0076	<b>101</b>	TGN0026	<b>59</b>	TSL0015	<b>87</b>		
TCS0085	<b>115</b>	TGN0027	<b>61</b>	TSL0016	<b>87</b>		
TCV0001	<b>33</b>	TGN0028	<b>63</b>	TSL0017	<b>87</b>		
TCV0002	<b>19</b>	TGN0029	<b>79</b>	TSL0018	<b>95</b>		
TCV0007	<b>19</b>	TGN0030	<b>81</b>	TSL0019	<b>91</b>		
TCV0008	<b>33</b>	TGN0031	<b>85</b>	TSL0020	<b>95</b>		
TCV0009	<b>33</b>	TGN0033	<b>83</b>	TSL0021	<b>111</b>		
TCV0010	<b>33</b>	TGN0034	<b>69</b>	TSL0030	<b>87</b>		
TCV0011	<b>19</b>	TGN0035	<b>65</b>	TSL0031	<b>89</b>		
TCV0015	<b>37</b>	TGN0036	<b>29</b>	TSL0032	<b>93</b>		
TCV0016	<b>37</b>	TGN0037	<b>57</b>	TSL0033	<b>89</b>		
TCV0017	<b>23</b>	TGN0038	<b>63</b>	TSL0034	<b>93</b>		
TCV0018	<b>21</b>	TGN0039	<b>59</b>	TSL0035	<b>89</b>		
TCV0019	<b>35</b>	TGN0040	<b>61</b>	TSL0036	<b>93</b>		
TCV0020	<b>35</b>	TGN0041	<b>79</b>	TSL0037	<b>87</b>		
TCV0021	<b>35</b>	TGN0042	<b>81</b>	TSL0038	<b>95</b>		
TCV0022	<b>35</b>	TGN0043	<b>59</b>	TSL0039	<b>89</b>		
TCV0023	<b>35</b>	TGN0044	<b>61</b>	TSL0040	<b>93</b>		
TFR0001	<b>26</b>	TGN0045	<b>63</b>	TSL0041	<b>89</b>		