

leto
by

GAIA
baby



IMPORTANT!

EN

**RETAIN FOR FUTURE REFERENCE:
READ CAREFULLY**

IMPORTANTE:

ES

**LEA ESTAS INSTRUCCIONES DETENIDAMENTE Y
GUÁRDELAS PARA FUTURA REFERENCIA**

IMPORTANT :

FR

**VEUILLEZ LIRE CES CONSIGNES AVEC ATTENTION ET LES
CONSERVER POUR VOUS Y REPORTER ULTÉRIEUREMENT**

ACHTUNG:

D

**BITTE LESEN SIE SICH DIESE ANWEISUNGEN
SORGFÄLTIG DURCH UND BEWAHREN SIE SIE FÜR
ZUKÜNFTIGE VERWENDUNG AUF**

IMPORTANTE:

IT







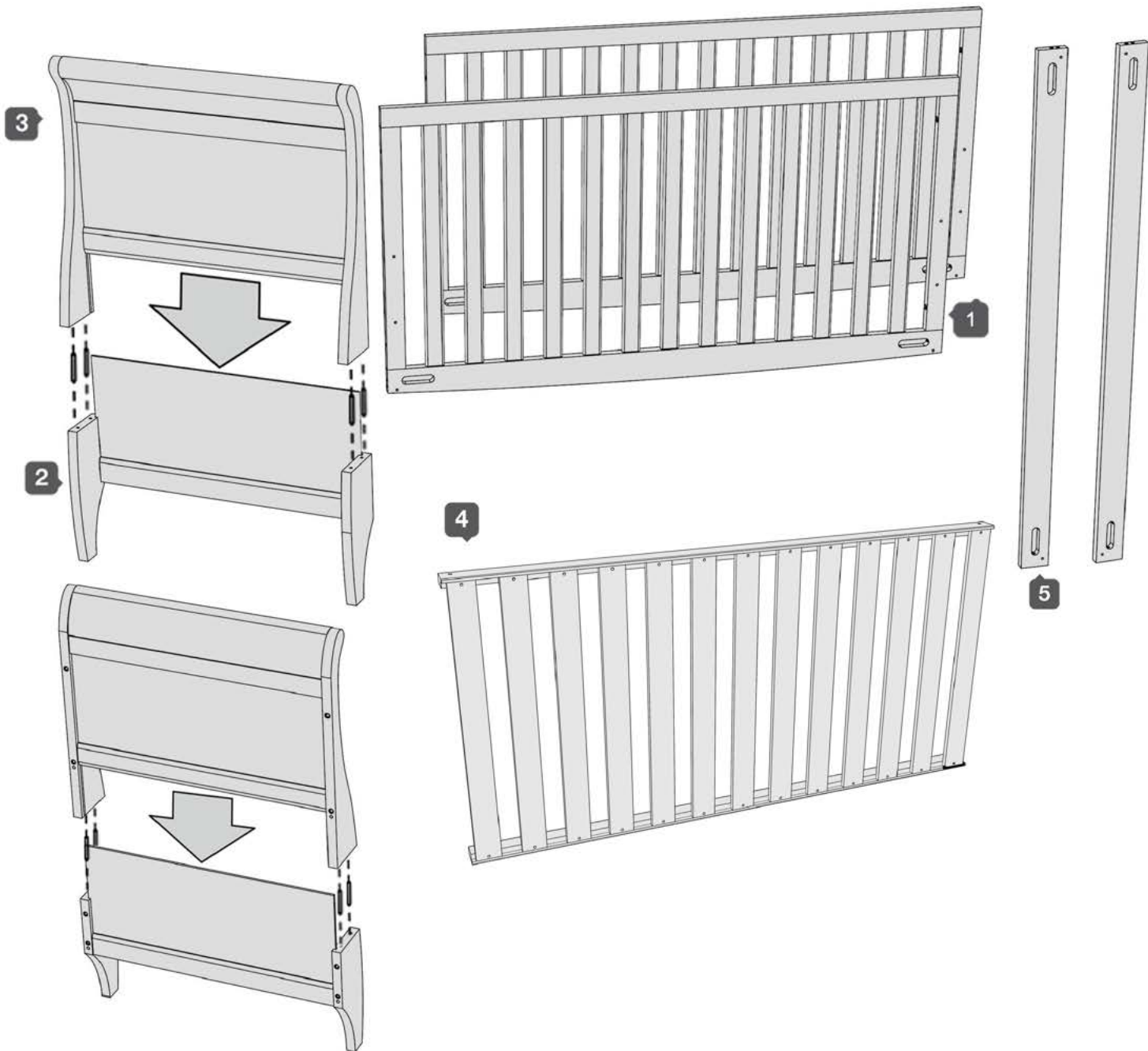

**LEGGERE ATTENTAMENTE QUESTE ISTRUZIONI E
CONSERVARLE COME RIFERIMENTO FUTURO**

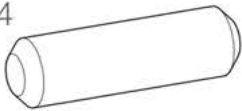
BELANGRIJK!

NL

**BEWAAR VOOR TOEKOMSTIGE REFERENTIE:
LEES DIT ZORGVULDIG DOOR**

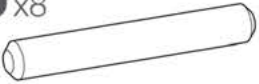

A x4 	B x8  60mm	C x1 
D x4  45mm	E x4 	F x4 
G x8 	H x4 	i x8 



1 - 9



10 - 16

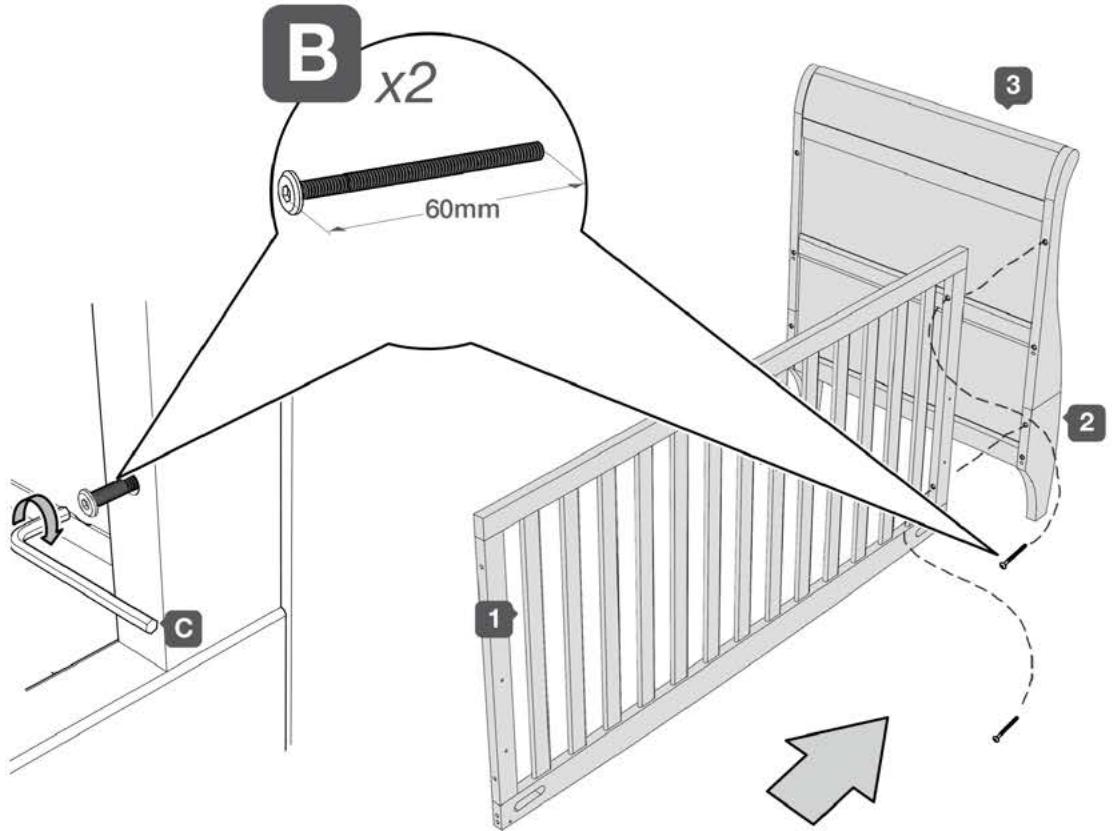
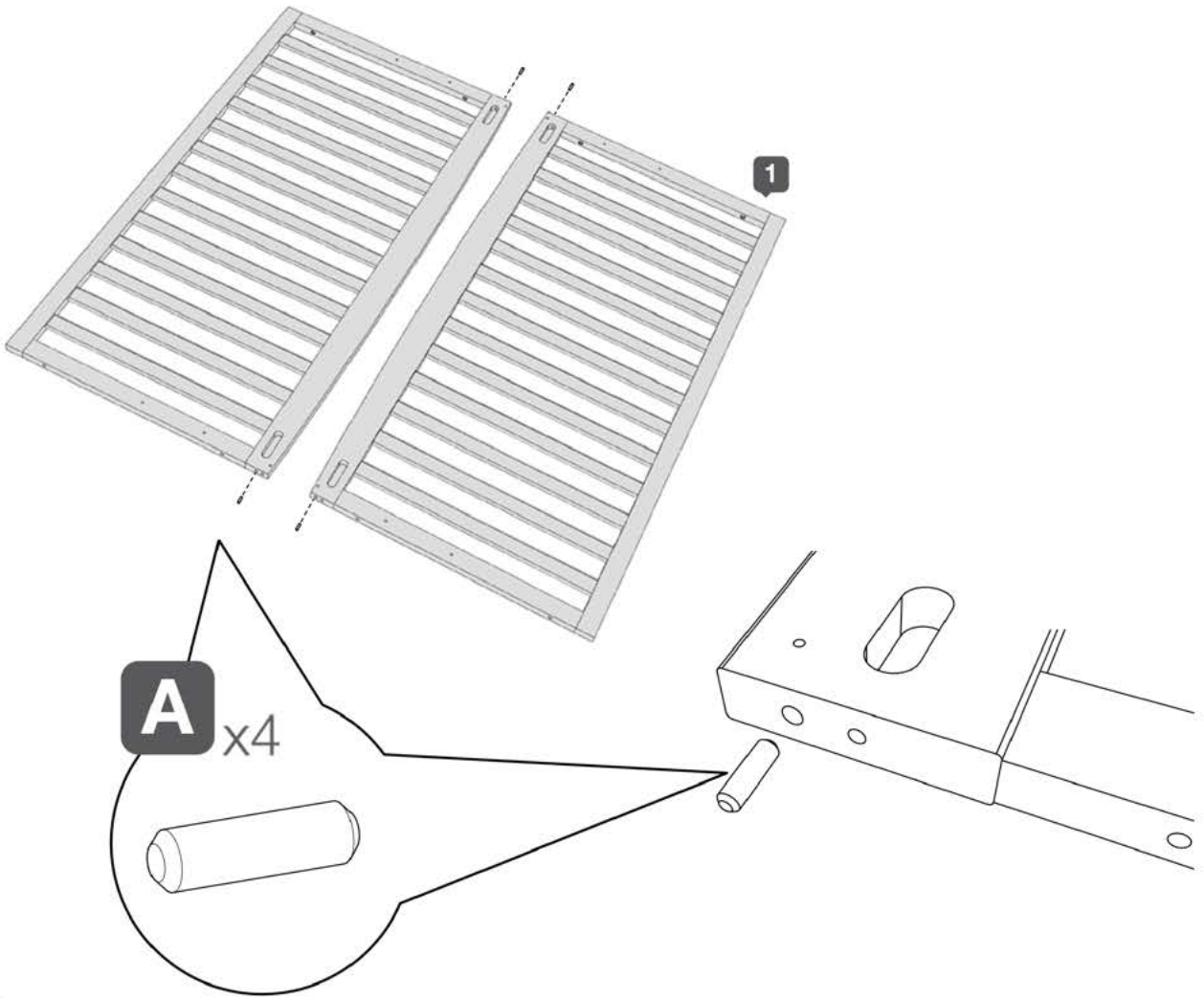

3

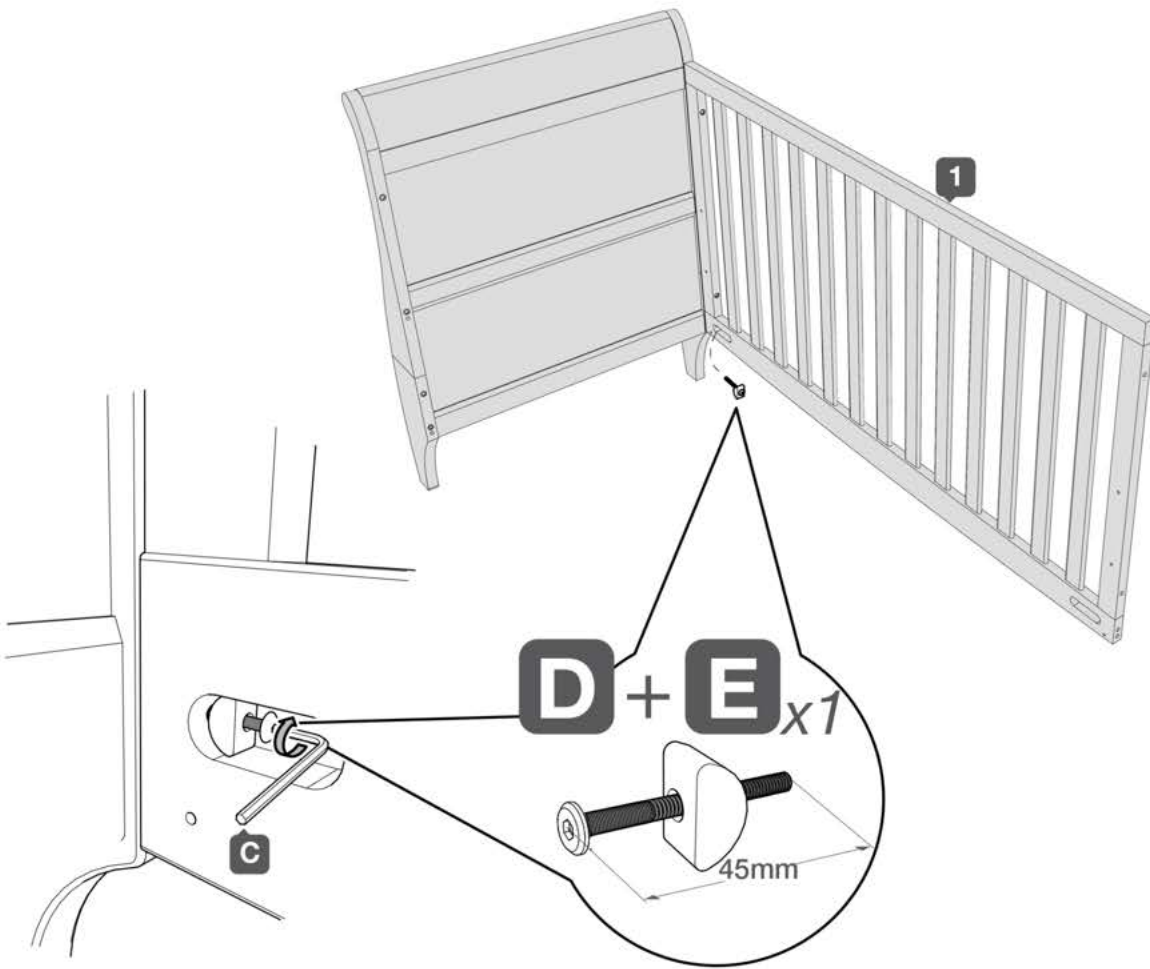

4

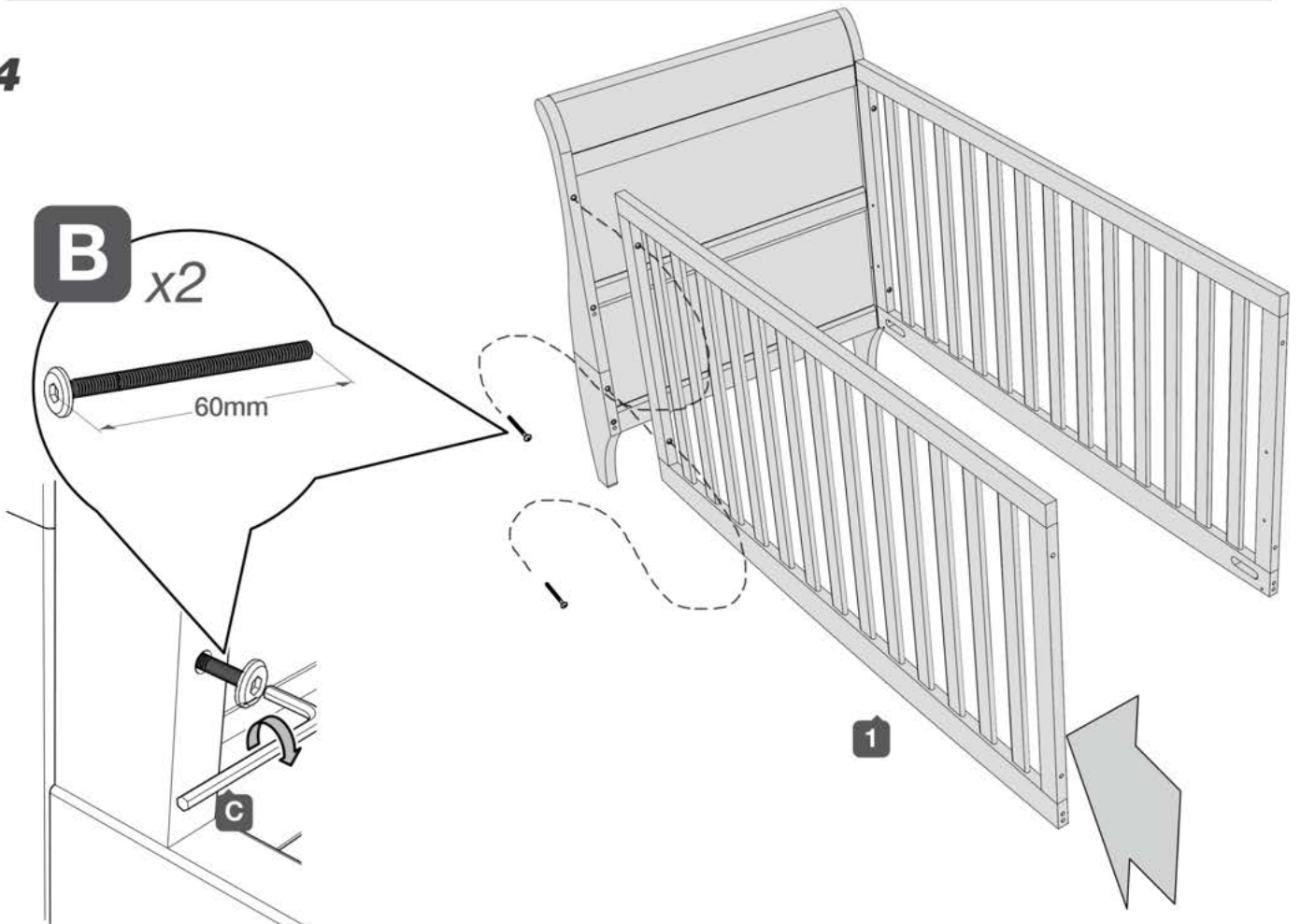

5

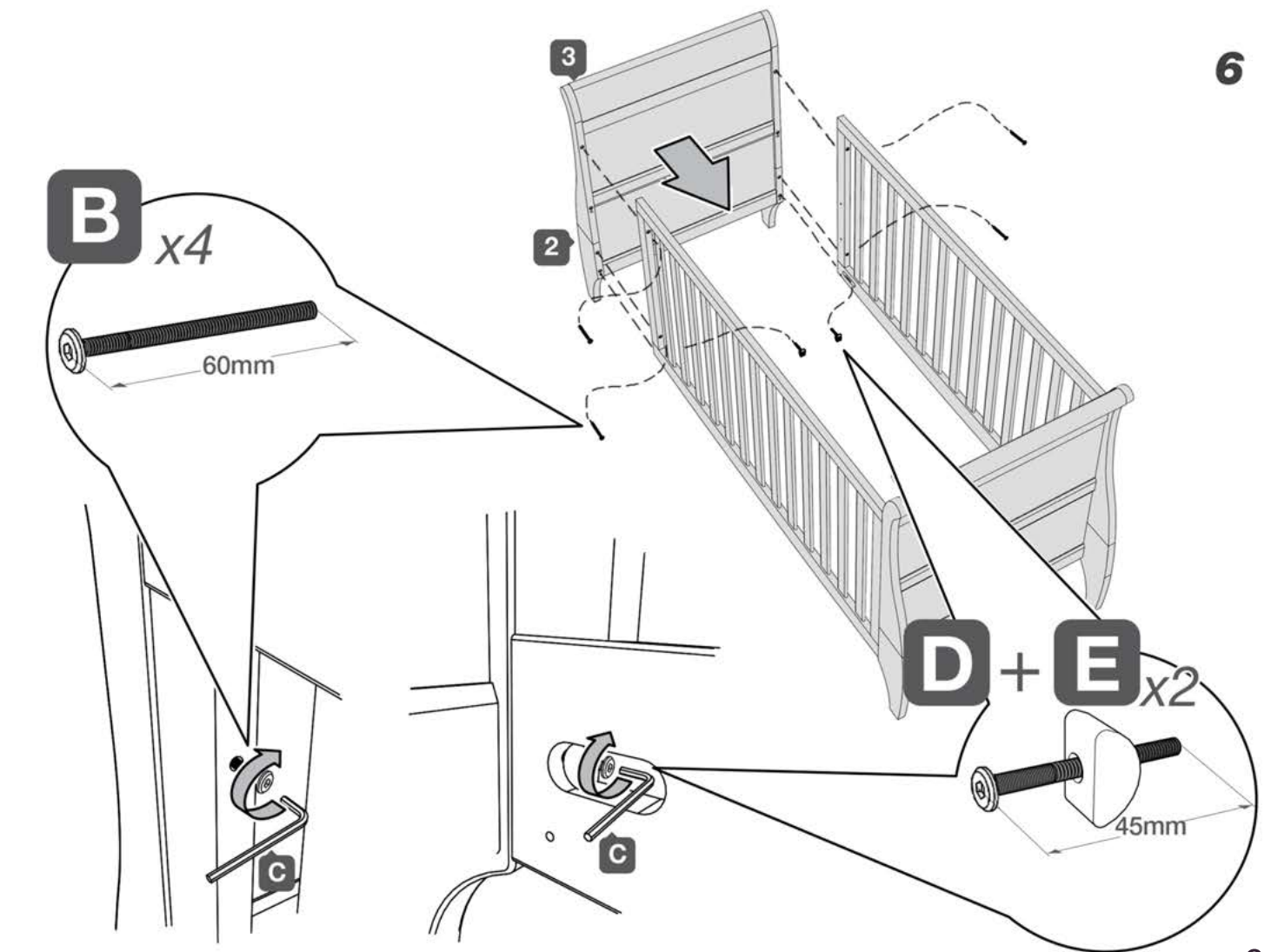
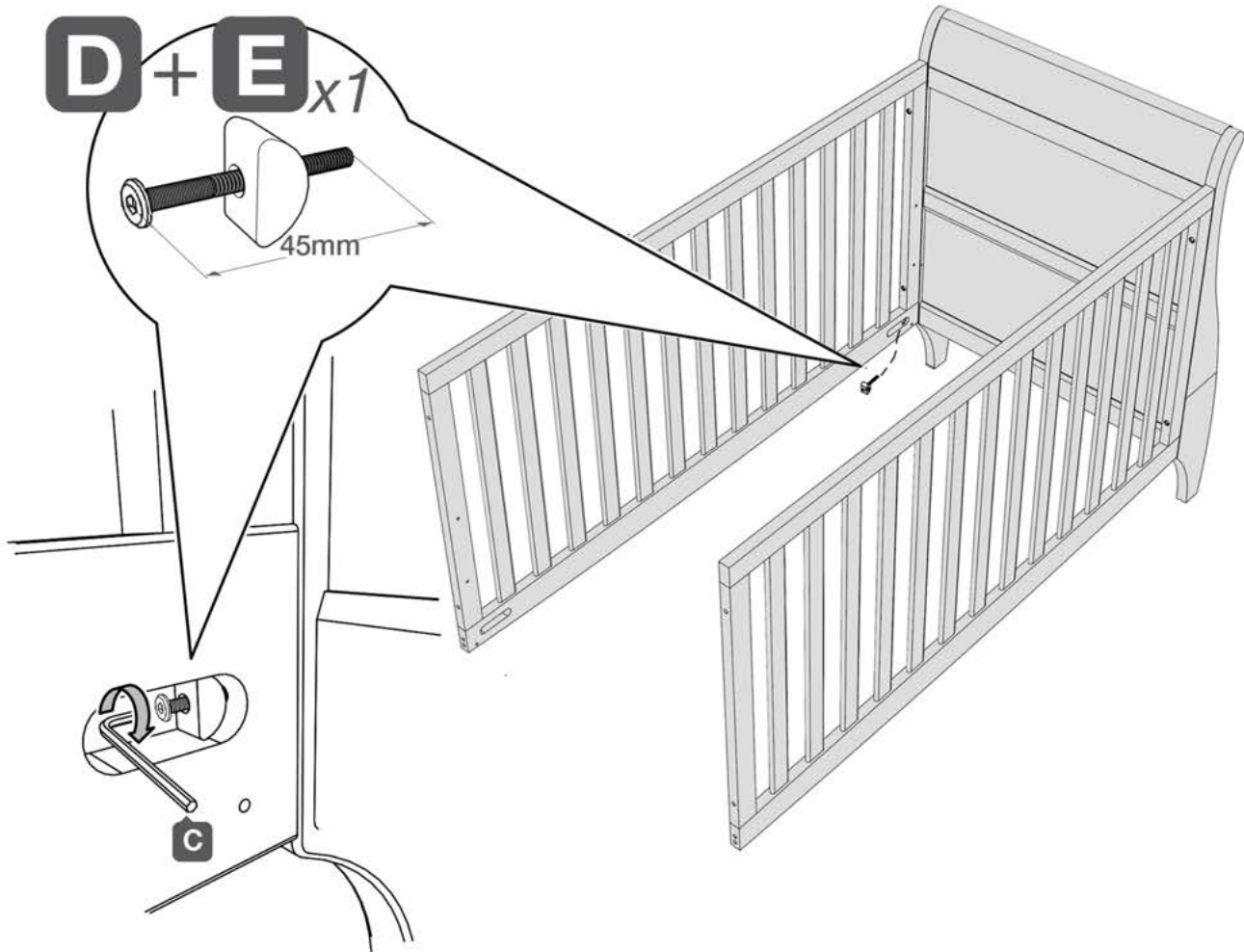

7

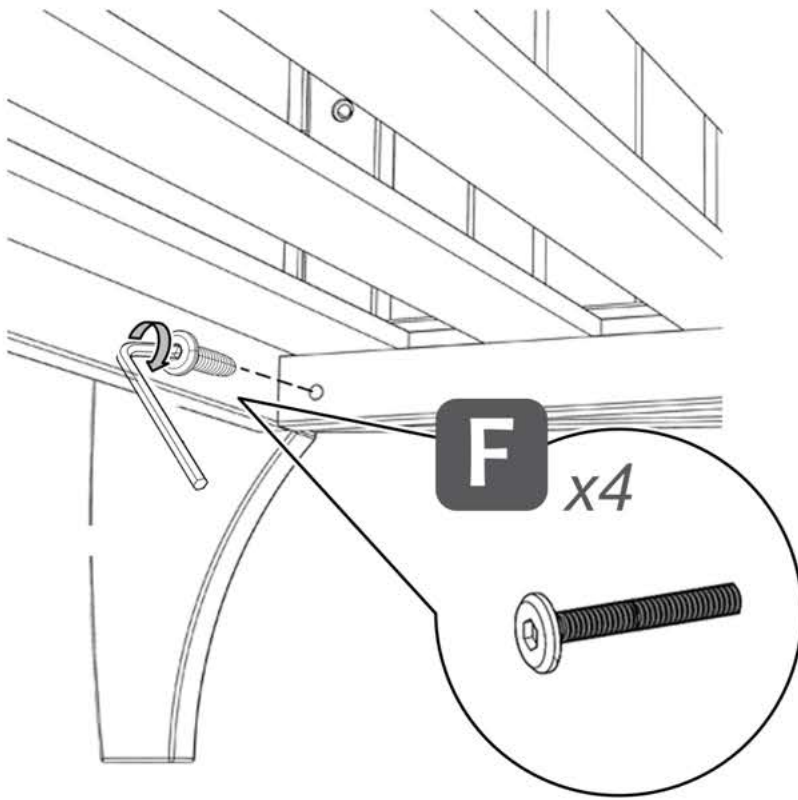

8

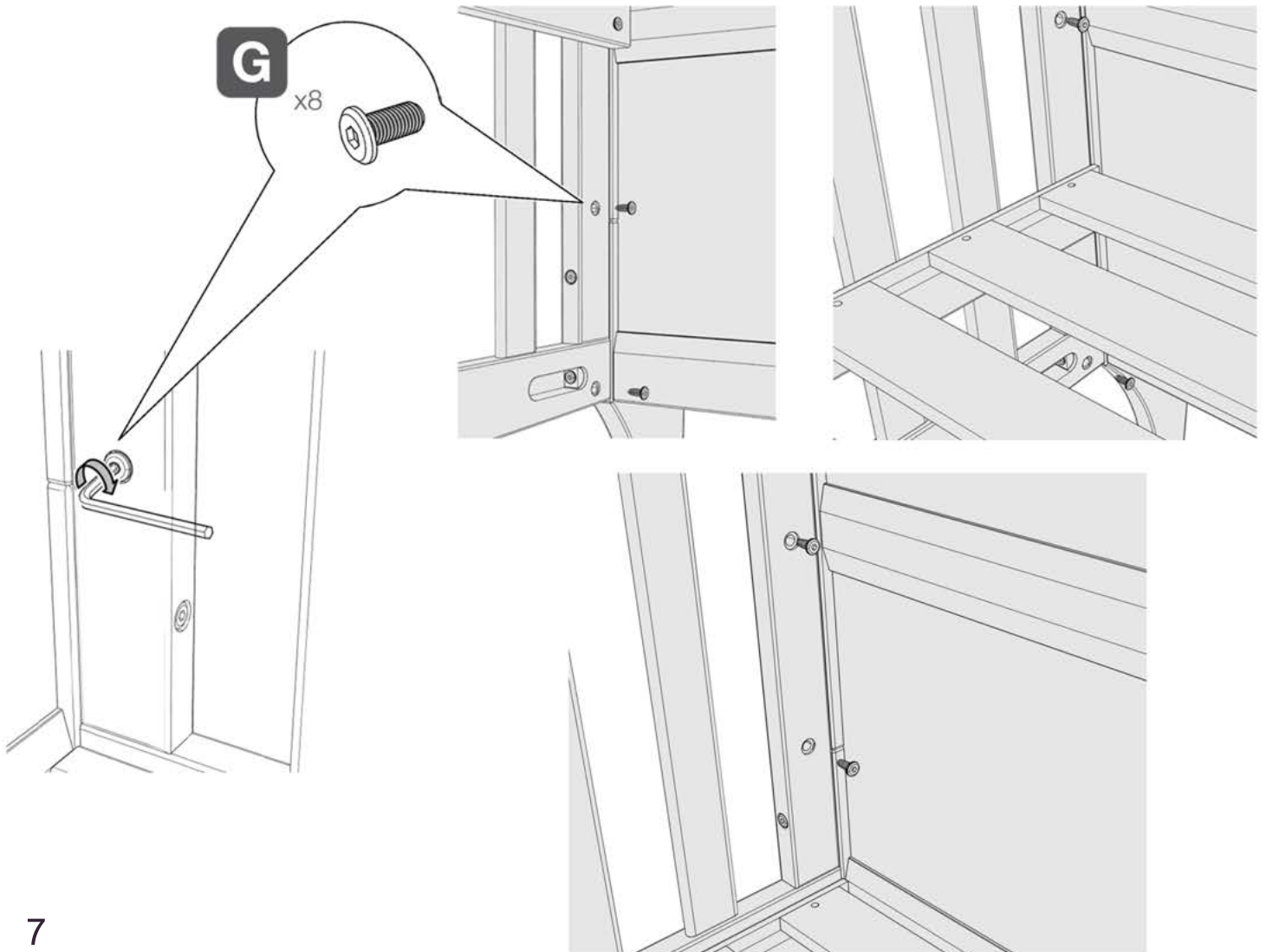

7



Finished

Concluido

Fini

Fertig

Finito

Voltooid

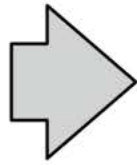

10

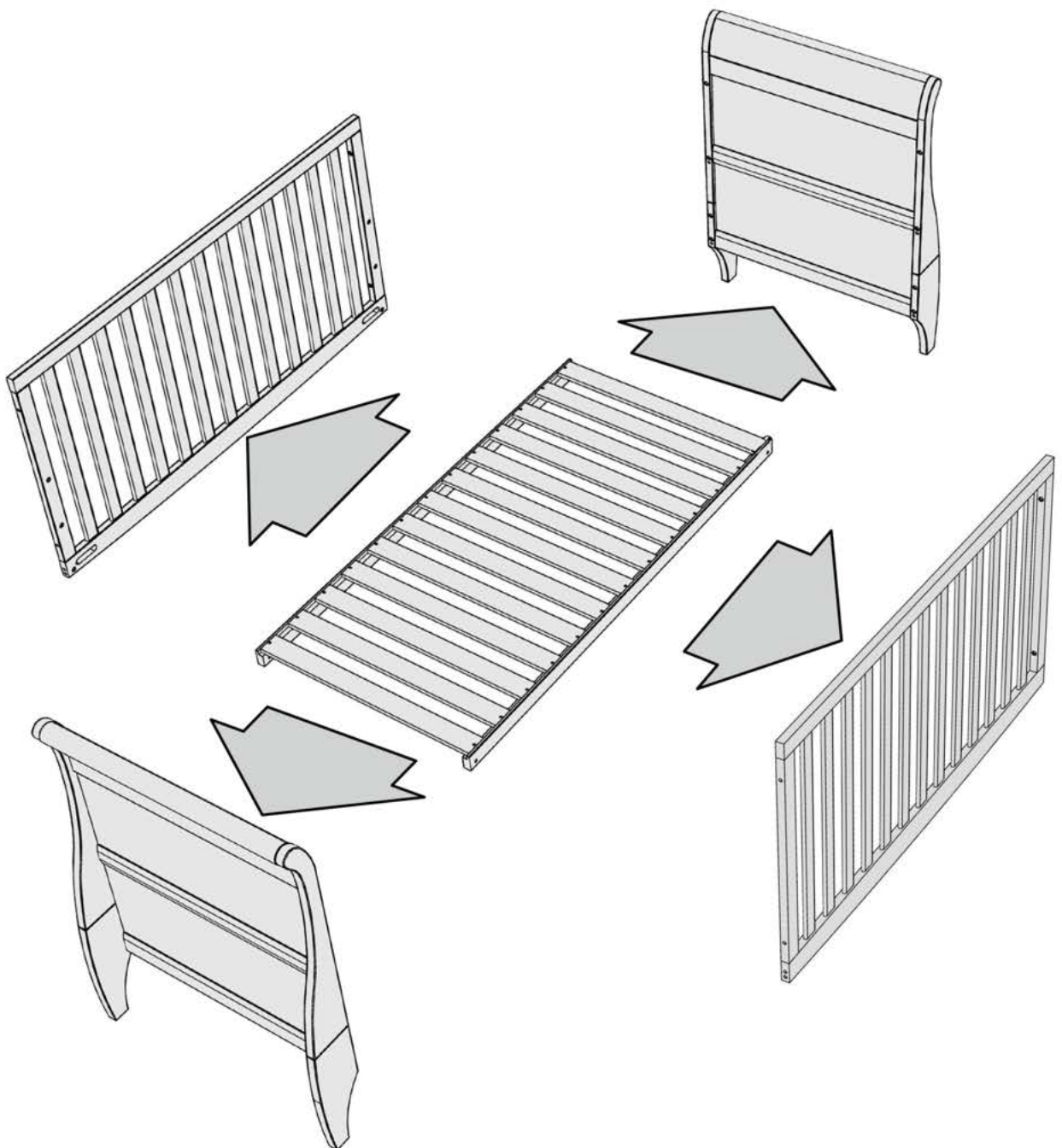

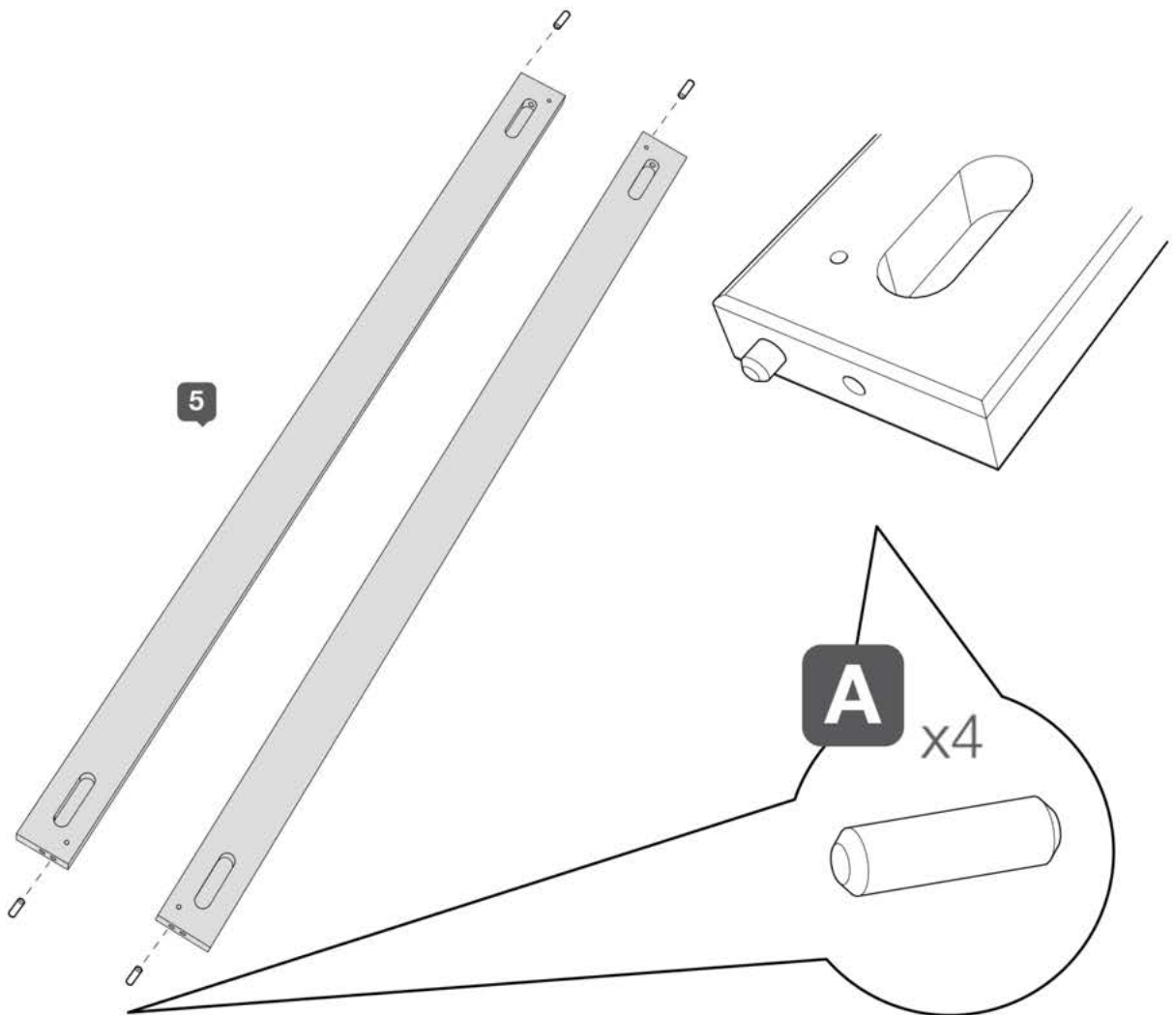
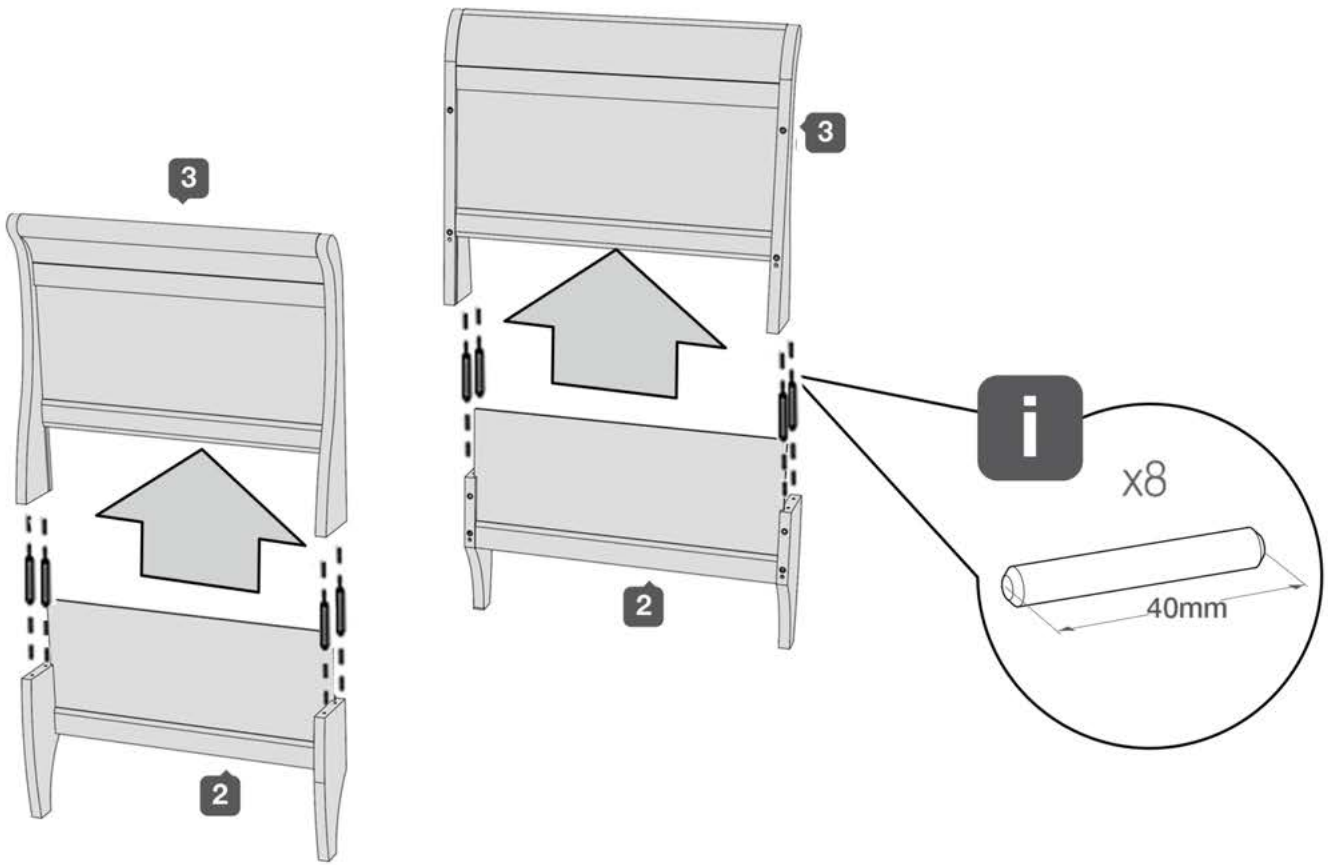

13

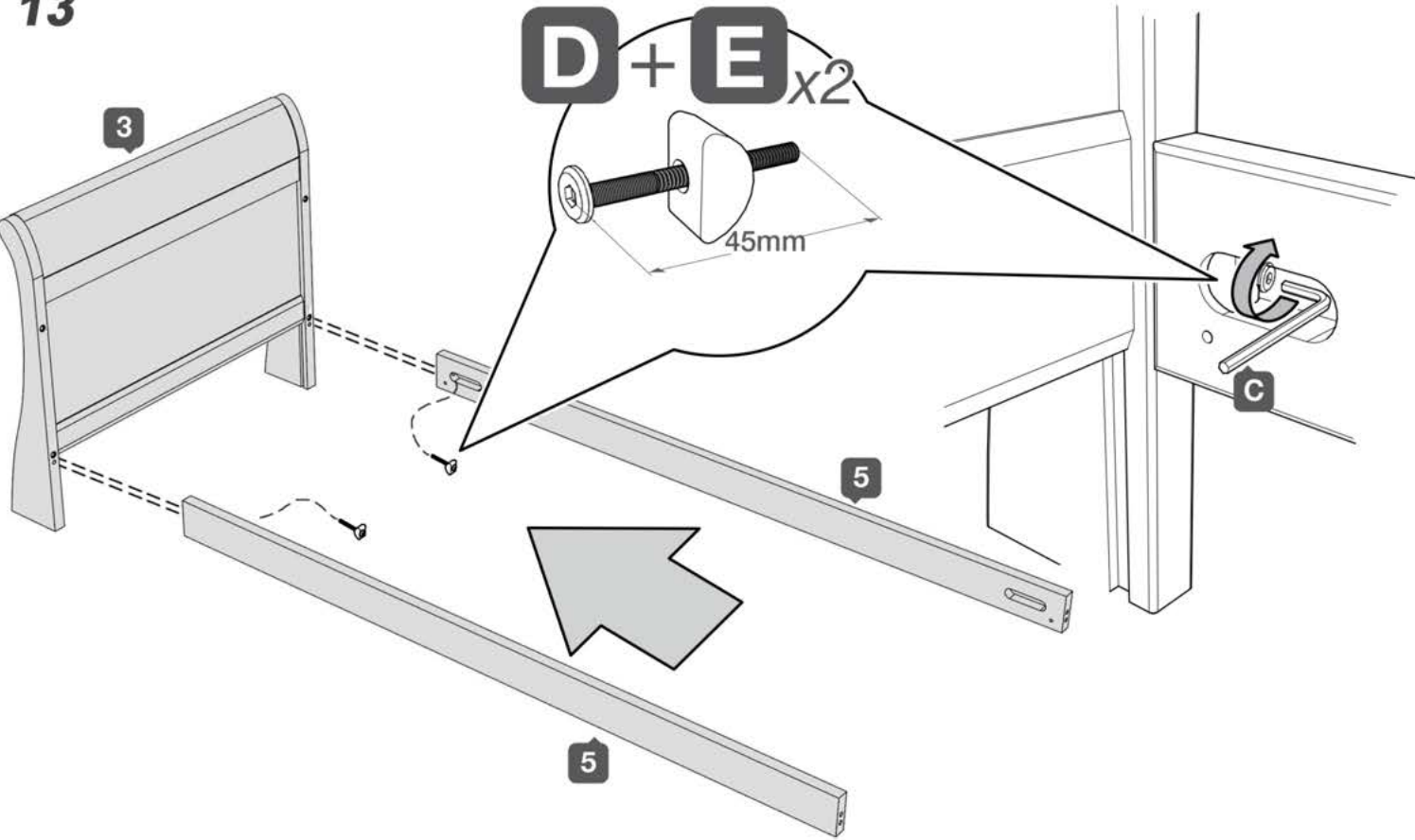

14

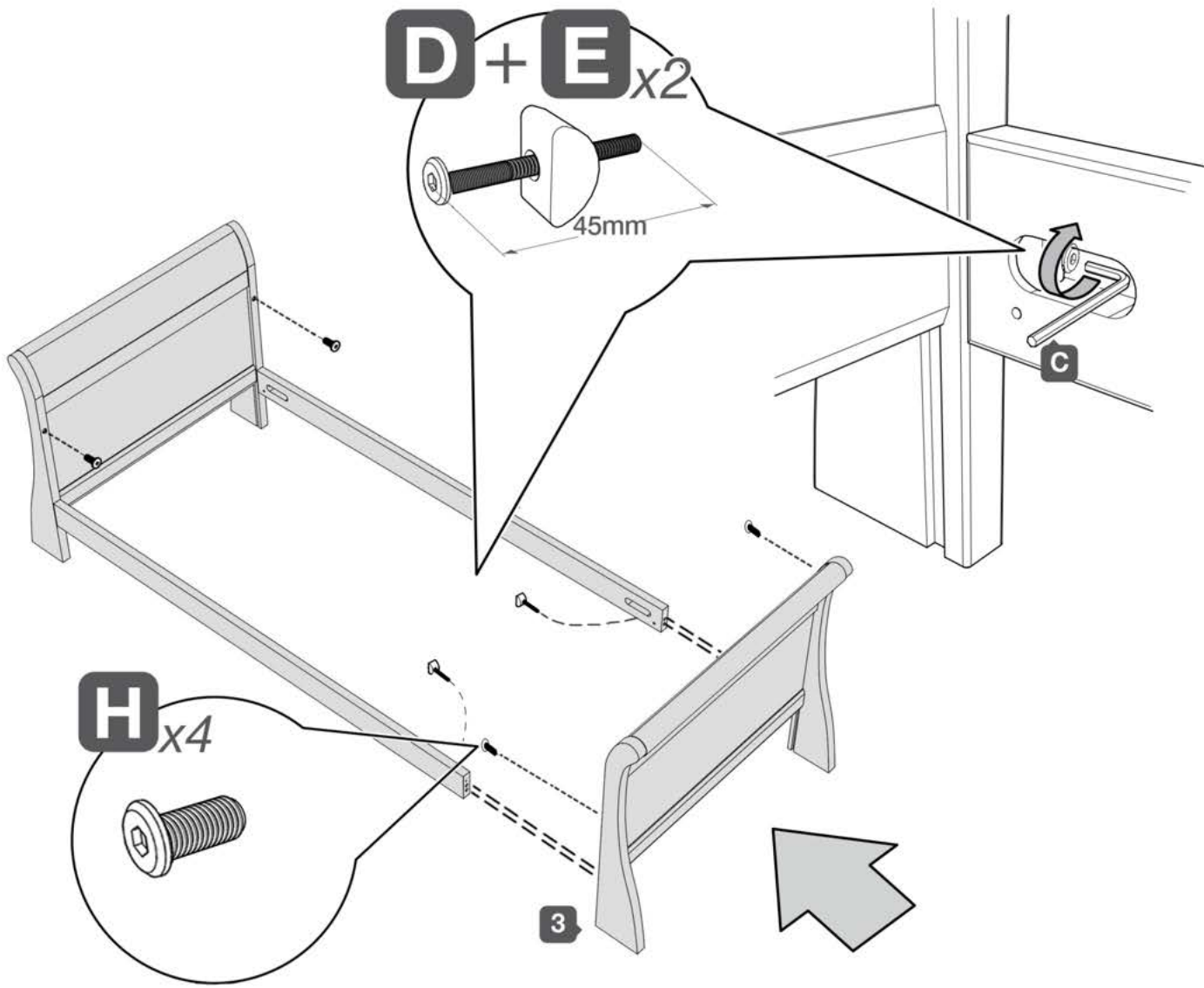

17

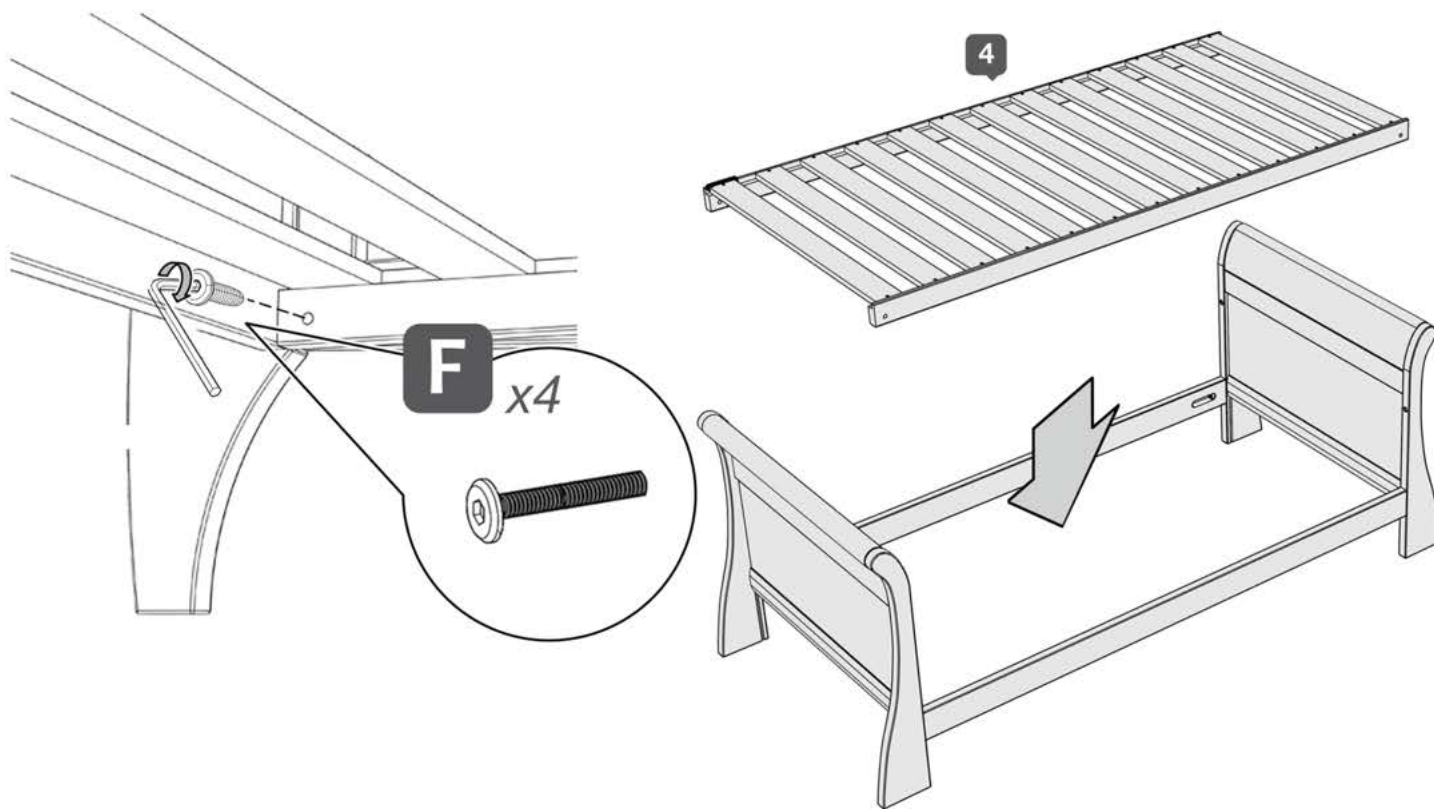

18

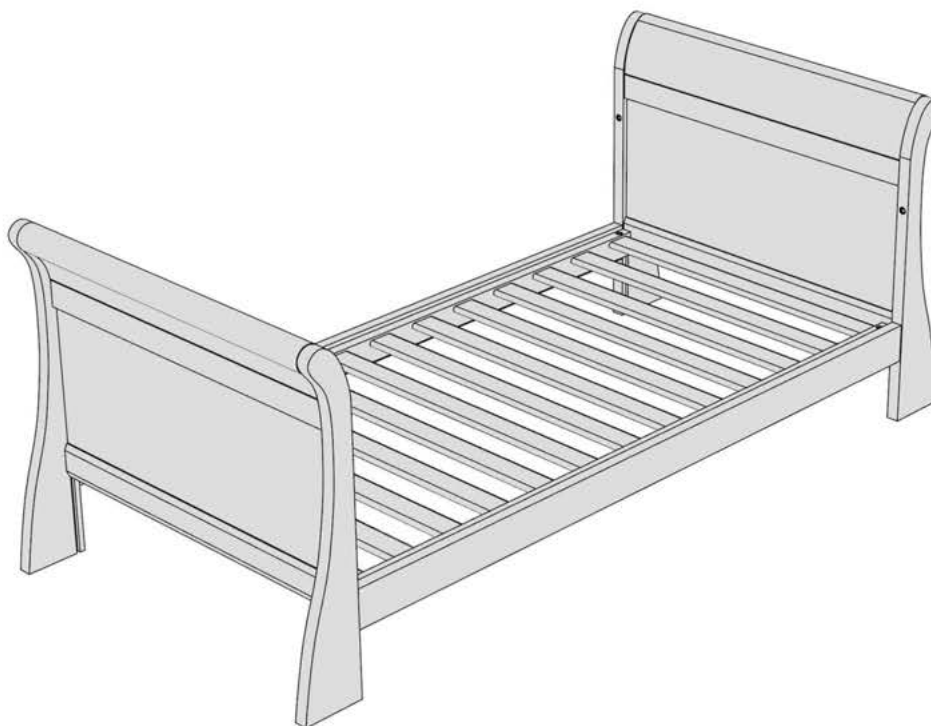

Finished

Concluido

Fini

Fertig

Finito

Voltooid

- **WARNING:** Do not use the cot if any part is broken, torn or missing and use only spare parts approved by the manufacturer.
- **WARNING:** Be aware of the risk of open fire and other sources of strong heat, such as electric bar fires, gas fires, etc. in the near vicinity of the cot.
- **WARNING:** Do not leave anything in the cot or place the cot close to another product, which could provide a foothold or present a danger of suffocation or strangulation, e.g. strings, blind/curtain cords etc.
- **WARNING:** Do not use more than one mattress in the cot.
- The lowest position is the safest. Once your child is old enough to sit up unaided the base should be used in the lowest position.
- The thickness of the mattress chosen shall be such that the integral height (surface of the mattress to the upper edge of the cot frame) is at least 500mm in the lowest position of the bed base and at least 200mm in the highest position of the bed base.
- The length and width shall be such that the gap between the mattress and the sides and ends does not exceed 30mm.
- To prevent injury from falls, once the child is able to climb out of the cot, it should no longer be used for that child.
- **WARNING.** Do not place this child's bed near heat sources, windows and other furniture.
- **WARNING.** Do not use this child's bed if any part is broken, torn or missing.
- This child's bed conforms to BS8509:2008 + A1:2011.
- When converted to a bed, this product is suitable from 18 months to 4 years
- The mattress should be no more than 30mm shorter or narrower than the internal length or width of the cot/bed.
- This child's bed is designed to be dismantled for transportation or storage.
- Periodically check that all fittings are tightened properly before use.
- This child's bed may be cleaned with a damp cloth. Never use bleach or harsh abrasives.
- Children are likely to play, bounce, jump and climb on beds, therefore the child's bed should not be placed too close to other furniture or windows, and should be placed either tight to any wall or have a gap of 300mm between the wall and the side of the bed.

- **ADVERTENCIA:** No utilice la cuna/cama infantil si alguna de las piezas está rota o estropeada, o si falta alguna pieza y use sólo piezas de repuesto aprobadas por Gaia baby.
- **ADVERTENCIA:** Debe ser consciente del riesgo de chimeneas y otras fuentes de calor fuerte como fuegos eléctricos, fuegos de gas, etc, cerca de la cuna.
- **ADVERTENCIA:** No deje nada en la cuna ni deje la cuna cerca de otro producto que pudiera servir como punto de apoyo o suponer un peligro de asfixia o estrangulamiento como por ejemplo cordeles o cordones de cortinas/persianas, etc.
- **ADVERTENCIA:** No use más de un colchón en la cuna.
- Asegúrese de que todos los herrajes estén bien apretados antes del uso. Se deberían revisar y apretar los herrajes con regularidad cuando sea necesario.
- Puede limpiar la cuna/cama con un trapo húmedo. No utilice nunca lejía ni productos abrasivos fuertes.
- La posición más baja de la base es la más segura. Una vez su hijo sea lo suficientemente mayor para sentarse sin ayuda, la base debería usarse exclusivamente en la posición más baja.
- El grosor del colchón elegido deberá ser tal que la altura interna (desde la superficie del colchón hasta el borde superior del marco de la cuna) sea de al menos 500 mm en la posición más baja de la base y al menos 200 mm en la posición más alta de la base.
- El colchón no debería ser más de 30 mm más corto o más estrecho que el largo o el ancho interior de la cuna.
- Para evitar lesiones por caídas, una vez que el niño pueda salir sólo de la cuna, ésta no debería ser utilizada más para ese niño.

- **ATTENTION:** N'utilisez pas le petit lit si une partie, quelle qu'elle soit, est cassée, déchirée ou manquante, et utilisez exclusivement des pièces de rechange agréées par Gaia baby.
- **ATTENTION:** Soyez vigilant aux risques que présentent des feux de cheminée et d'autres sources de chaleur intense (feux à barres électriques, feux au gaz, etc...) à proximité du petit lit.
- **ATTENTION:** Ne laissez rien dans le petit lit et ne posez pas le petit lit à côté d'un autre objet qui pourrait servir de marchepied ou présenter un risque d'étouffement ou de strangulation, par ex. : cordes, cordons pour store/rideaux, etc...
- **ATTENTION:** N'utilisez pas plus d'un matelas dans le petit lit.
- Vérifiez que toutes les fixations sont bien serrées avant de l'utiliser. Les fixations doivent être vérifiées et serrées régulièrement s'il y a lieu.
- Entretien : Le petit lit/lit enfant peut être nettoyé au chiffon humide. N'utilisez jamais d'eau de Javel ni d'abrasifs puissants.
- La position la plus basse du sommier est celle la plus sûre. Dès lors que votre enfant est suffisamment grand pour s'asseoir tout seul, utilisez le sommier exclusivement dans sa position la plus basse.
- L'épaisseur du matelas choisi doit être telle que la hauteur interne (écart entre la surface du matelas et le bord supérieur du cadre du petit lit) doit être d'un minimum de 50 cm sur la position la plus basse du sommier et de 20 cm dans la position la plus haute du sommier.
- Le matelas ne doit pas être plus court ni plus étroit de 3 cm par rapport à la largeur ou la longueur internes du berceau.
- Pour empêcher les blessures causées par des chutes, une fois que l'enfant est suffisamment grand pour sortir de son lit tout seul, ce lit ne lui convient plus.

- **WARNUNG:** Die Wiege bzw. das Kinderbett darf nicht verwendet werden, wenn ein Teil defekt oder deformiert ist oder vollständig fehlt. Verwenden Sie nur die von Gaia baby empfohlenen Ersatzteile.
- **WARNUNG:** Denken Sie an das Risiko durch offenes Feuer und andere starke Wärmequellen, wie zum Beispiel elektrische Feuer, Gasbrenner etc. in der unmittelbaren Nähe des Kinderbetts.
- **WARNUNG:** Lassen Sie keine Gegenstände im Kinderbett liegen und stellen Sie es nicht in die Nähe eines anderen Produkts, auf den das Kind seinen Fuß stellen könnte, oder das eine Erstickungs- oder Strangulationsgefahr – z. B. Seile, Rollladen- oder Vorhangbänder etc. – darstellen könnte.
- **WARNUNG:** Verwenden Sie in dem Kinderbett nicht mehr als eine Matratze
- Bitte stellen Sie vor der erstmaligen Verwendung sicher, dass alle Befestigungen korrekt angezogen sind. Die Beschläge sollten regelmäßig überprüft und im Bedarfsfall angezogen werden.
- Ihr Bett kann mit einem feuchten Tuch gereinigt werden. Niemals Bleichmittel oder aggressive Scheuermittel verwenden.
- In der niedrigsten Grundplatten-Position ist die Sicherheit am größten. Sobald Ihr Kind ohne Hilfe aufrecht sitzen kann, sollte die Grundplatte nur in der niedrigsten Position verwendet werden.
- Die Dicke der ausgewählten Matratze sollte sich so darstellen, dass die interne Höhe (Oberkante der Matratze bis zur Oberkante des Kinderbettrahmens) in der niedrigsten Position der Bett-Grundplatte mindestens 500mm und mindestens 200mm in der höchsten Position der Bett-Grundplatte beträgt.
- Die Matratze darf nicht mehr als 30 mm kürzer oder schmaler als die interne Länge bzw. Breite des Bettchens sein.
- Sobald das Kind in der Lage ist, aus dem Kinderbett zu klettern, sollte das Bett aus Sicherheitsgründen nicht mehr für dieses Kind verwendet werden.

- **AVVERTENZA:** Non utilizzare il lettino/letto in presenza di componenti danneggiati, lacerati o mancanti e utilizzare solo ricambi approvati da Gaia baby.
- **AVVERTENZA:** Fare attenzione alla presenza di fuochi o altre fonti di calore elevato, come fornelli elettrici, a gas, ecc. nelle vicinanze del lettino.
- **AVVERTENZA:** Non lasciare nessun oggetto nel lettino né posizionare il lettino accanto ad altri oggetti che potrebbero servire al vostro bambino da punto di appoggio per sollevarsi o rappresentare pericolo di soffocamento o strangolamento come lacci, cordoni di avvolgibili/tende, ecc.
- **AVVERTENZA:** Sistemare nel lettino un solo materasso.
- Verificare che tutti gli elementi di fissaggio siano serrati correttamente prima dell'utilizzo. Verificare e serrare gli elementi di fissaggio ove necessario.
- Pulire il lettino/letto con un panno umido. Non applicare mai sbiancanti o detergenti abrasivi.
- La posizione più bassa del lettino è quella più sicura. Quando il vostro bambino è abbastanza grande da poter stare seduto senza bisogno di aiuto, la base deve essere utilizzata esclusivamente nella posizione più bassa.
- Lo spessore del materasso scelto dovrà essere tale da avere un'altezza interna (dalla superficie del materasso al bordo superiore del telaio del lettino) di almeno 500 mm nella posizione più bassa della base del letto e almeno 200 mm nella posizione più alta.
- Il materassino non deve essere più corto o stretto di 30 mm rispetto alla lunghezza o alla larghezza interna della culla.
- Per evitare lesioni in seguito a cadute, quando il bambino è in grado di arrampicarsi e uscire dal lettino, interromperne l'utilizzo.

- **WAARSCHUWING:** Het babybedje/kinderbed niet gebruiken als een onderdeel is gebroken, gescheurd of ontbreekt. Gebruik alleen reserveonderdelen die door Mamas & Papas zijn goedgekeurd.
- **WAARSCHUWING:** Wees bewust van de risico's van open vuur en andere sterke hittebronnen, zoals elektrische straalkachels, gaskachels enzovoorts in de buurt van het babybedje.
- **WAARSCHUWING:** Laat niets in het babybedje achter en plaats het bedje niet naast een ander product dat kan dienen als een plaats om op te staan of waardoor er gevaar bestaat voor verstikking of wurging, bijv. een snoer, een rolgordijn-/gordijnkoord enz.
- **WAARSCHUWING:** Leg niet meer dan één matras in het babybedje.
- Zorg voor gebruik ervoor dat alle onderdelen stevig en goed bevestigd zijn. De onderdelen moeten regelmatig gecontroleerd worden en waar nodig nog eens stevig worden vastgemaakt.
- Het babybedje/kinderbed kan met een vochtige doek worden afgenomen. Gebruik geen bleekmiddelen of agressieve schuurmiddelen.
- De laagste stand van de bedbodem is het veiligst. Wanneer uw kind oud genoeg is om zelfstandig rechtop te zitten, gebruik dan uitsluitend de bedbodem in de laagste stand.
- De hoogte van de gekozen matras moet zodanig zijn dat de interne hoogte (bovenkant van de matras tot de bovenste rand van het frame van het babybedje) minstens 500 mm is als de bedbodem in de laagste stand staat en minstens 200 mm als de bedbodem in de hoogste stand staat.
- De matras mag niet meer dan 30 mm korter en smaller zijn dan de lengte en breedte van de binnenkant van de wieg.
- Om verwondingen door vallen te voorkomen, moet het babybedje zodra het kind eruit kan klimmen, voor hetzelfde kind niet langer worden gebruikt.

- **RECOMMENDED MATTRESS SIZE** This cot has been manufactured for use with a mattress which measures 700mm wide by 1400mm long and 100mm in thickness. The width and length are specified because it is important that the gaps between the mattress and the sides and ends of the cot will not exceed 30mm. This is to minimize the risk of a child's limb getting caught in the gap. The thickness of the mattress has been specified to ensure that the depth of the cot is greater than 500mm with the mattress base in the lowest position to minimize the risk of a child climbing or falling out of the cot.
 - **WARNING: TO PREVENT FALLS, THE MATTRESS BASE OF THIS COT SHOULD BE ADJUSTED TO THE LOWEST POSITION BEFORE THE CHILD CAN SIT UP.**
 - Read and follow the manufacturer's assembly instructions in detail before assembling this product to ensure the safety features of the cot are not compromised.
 - **WARNING:** Be aware of the risk of open fire and other sources of strong heat, such as electric bar fires, gas fires, etc. in the near vicinity of the cot.
 - Always ensure that the cot is placed at a reasonable distance from curtains, binds, heaters and power points.
 - Always keep medication, string, elastic, small toys or small items, such as money out of reach from any position in the cot.
 - Periodically check that all fittings are tightened properly before use.
 - This cot may be cleaned with a damp cloth. Never use bleach or harsh abrasives.
-



Gaia Baby Nursery



www.gaia-baby.com



UK T: +353 1 828 4823



Gaiababynursery