

GAS SERIES



TOFINO z25

Zero-Clearance
Gas Fireplace



TOFINO z25

Zero-Clearance
Gas Fireplace



The Tofino Series of gas fireplaces offers you the highest level of quality, technical innovation, and performance for your home. Designed for new construction and renovation projects, the z25 provides maximum heat and ultimate energy efficiency with easy, one-touch programmable control. Heat output and flame heights are variable, allowing you complete control over comfort and appearance. Even at the lowest settings, the Tofino z25 flames are appealingly rich and full to gently warm your environment.





TOFINO z25

Tofino z25 is offered as a fully assembled fireplace with painted black steel firebox panels and a sparkling black glass burner. Upgrade your Tofino z25 with a Driftwood logset, four firebox panel options, and a 120 cfm variable speed blower.



Optional
Driftwood Logset



Remote control
included



FIELD CONVERTIBLE
Rear Vent / Top Vent



TOFINO z25
PREMIUM

Tofino z25 Premium comes as a fully assembled fireplace with painted black steel firebox panels, 120 cfm variable speed blower, and premium high definition log set on a ember bed lighting kit. Choose from four firebox panel options to compliment your room's decor.

PREMIUM OPTIONS INCLUDED

- Premium log burner**
- Ember bed lighting kit**
- Variable speed blower standard**



Remote control
included



Premium Model with optional Red Brick Firebox Panels

FIELD CONVERTIBLE
Rear Vent / Top Vent

Specifications

STANDARD FEATURES & OPTIONS

- | | |
|--------------------------|-----------------------------|
| SIT Proflame 2 system | Easy open door latch |
| Top interior lighting | Up front venturi adjustment |
| Preinstalled burner tray | LP conversion kit |
| Remote Control | Four firebox panel options |

FIREBOX UPGRADE OPTIONS



Black Porcelain Fluted LedgeStone Red Brick

BTU INPUT

NG high 25,000 BTU/hr	P.4.1 71.7%
NG low 13,500 BTU/hr	
LP high 24,000 BTU/hr	P.4.1 69.1%
LP low 13,500 BTU/hr	

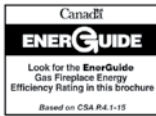

Models



Tofino z25

- Black Glass burner
- Optional Decorative Driftwood Logset
- Optional 120 cfm Variable Speed Blower

BURNER UPGRADE OPTIONS



Driftwood Logset



Tofino z25 Premium

- Premium Log Set Burner
- Ember Bed Lights
- 120 cfm Variable Speed Blower included

Dimensions & Clearances

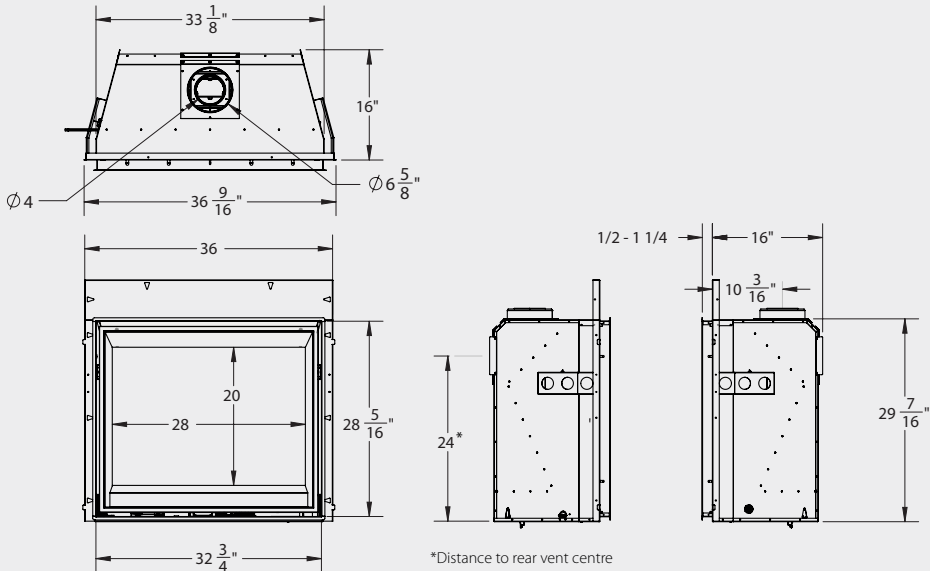

VENTING

Top Vent and Rear Vent, Field Convertible
 Rear Vent: 12" max straight, 18" max with 45°
 Vertical Vent: refer to installation manual

CLEARANCE TO COMBUSTIBLES

Ceiling from bottom of unit	65"
Chase height (top vented)	54"
Chase height (rear vented)	50"
Chase width	36"
Chase depth	16"
Clearance to sidewall from centre	22"
Objects in front of unit	36"
Hearth clearance	0"

MANTEL CLEARANCE FROM FLOOR

Mantel Depth	Mantel height from floor
2"	40"
6"	43.25"
12"	48"

For reference only. Installations should be based on manuals and rating labels.

Pacific Energy is committed to continuous product improvement and innovation. As a result, appearance and specifications of the products featured in this brochure are subject to change without notice.

For more information, please visit pacificenergy.net

SKU: 12900018 – Printed in Canada – 03/21/300



pacificenergy.net