

A50 Massage Chair

A50 User Manual

Please read all instructions before using.

Thank you for purchasing this product. Please read this user manual carefully before using to ensure proper installation and operation.

Please keep this USER MANUAL properly for future reference.





CONTENTS

SAFETY PRECAUTIONS -----	1
NAME AND FUNCTION OF EACH COMPONENT-----	4
External Structure-----	4
Internal Structure -----	4
Controller -----	5
Controller Instructions-----	5
VOICE FUNCTION -----	9
Voice activation-----	9
Voice guide function -----	10
FUNCTIONS AND FEATURES -----	11
PRELIMINARY CHECKS -----	12
Unpacking massage chair cartons-----	12
Moving the massage chair -----	13
Connecting to power -----	13
Position & placement for Installation -----	14
Floor Protection -----	15
Commissioning -----	16
Before sitting in the chair -----	16
Feet extension -----	17
Audio function -----	17
After Use -----	17
PRODUCT STORAGE AND MAINTENANCE -----	18
TROUBLESHOOTING -----	19
TECHNICAL SPECIFICATION -----	19

SAFETY PRECAUTIONS

Safety Precautions

- ▶ Read all warnings before using.
- ▶ Precautions and warnings listed below will help to ensure proper operation of this appliance.
- ▶ The classes of accidents caused by incorrect use are classified into WARNING and CAUTION.
- ▶ Read all WARNINGS and CAUTIONS below and follow all instructions within this manual.

 WARNING	Improper operation may cause injury to users.		
 CAUTION	Improper operation may cause injury to users or damage to product.		
	Prohibited		NO disassemble

Not suitable for below persons

We recommend that those with any of the following conditions should consult your physician before using.

 WARNING	<ul style="list-style-type: none"> ▶ Those with pacemaker or electronic device implemented in the body. ▶ Those undergoing treatment, especially those who are not feeling well. ▶ Those with malignant tumors, malignant abscesses, hypertension or heart disease (need to be supervised). ▶ Women who are pregnant or menstruating. ▶ Those with osteoporosis, distorted joints, dysfunction or recent fracture. ▶ Those with serious or injured skin conditions. ▶ Those with bad fever. ▶ This product is equipped with heat function, persons with reduced sensory of heat should pay attention to it. (Need to be supervised). ▶ Close supervision is necessary when this product is used by, on, or near children, invalids, or disabled persons. ▶ This Massager is equipped with heat function, persons with reduced sensory of heat should pay attention to it.
---	---

Control Panel Precautions

 CAUTION	<ul style="list-style-type: none"> ▶ Don't operate the controller with wet hands or pull the controller wire by force. ▶ Don't spill water or other liquid into the controller to avoid fault. ▶ Don't lay heavy items on the controller.
---	--

Cautions Regarding the Power Connectors and Power Cord

 CAUTION	<ul style="list-style-type: none"> ▶ Verify that the power voltage stated on the rating label corresponds to your local electricity supply. ▶ Do not use a wet hand to unplug the power cord to avoid electric shock. ▶ If the supply cord is damaged, it must be replaced by the manufacturer or its service agent or a similarly qualified person in order to avoid a hazard. ▶ Do not drag the cord, reach to the front plastic end to unplug it. ▶ Do not squeeze the AC cord by the appliance or other heavy objects. ▶ Do not damage, over bend, pull hard or twist the power cord.
---	---







SAFETY PRECAUTIONS

Control Panel Precautions

 CAUTION	<ul style="list-style-type: none"> ▶ Do not use this appliance where temperature is over 40 C. ▶ Do not use this appliance in moist or dusty environment. ▶ Unplug from outlet during thunder or lightning storms. ▶ Do not use outdoors. ▶ Please place the product on the flat level floor. ▶ Do not store near heat or open flame.
---	---

Best Practices for Safe Use

 CAUTION	<ul style="list-style-type: none"> ▶ Only for users weighs below 120kg. ▶ Do not use other therapeutic device together with this product. ▶ Use this product only for its intended use as described in this manual. ▶ Appliance should only be used by one person, do not use by two or more persons at the same time to avoid damage to the products. ▶ Do not use the product right after meal, it may cause discomfort. ▶ Remove the accessories from the arms and empty the pockets while using the massage services. ▶ Check the upholstery under the cushions and other spots, if any damages are present, do not use it and refer to a qualified service professional for servicing. If you feel any abnormal discomfort during the operation of this product, stop use immediately. ▶ Use the appliance for 20 minutes each time is highly recommended. ▶ Make sure there is no obstacles behind the chair and there is enough clearance before adjusting the backrest or footrest angle. ▶ Make sure no other excessive load pressed on the backrest or footrest, keep children,pets or any other barrier away from the unit reclining backrest/extending footrest to prevent any accidental injury. ▶ Do not sit on the appliance to avoid injury jury to the user or damage to the appliance. ▶ Do not drag or push the chair or roll on its casters on wood floor or carpet to avoid damage.
 PROHIBITED	<ul style="list-style-type: none"> ▶ Never operate this product if it has damaged / exposed parts or power leakage. ▶ Do not stand on or stack heavy objects on the footrest. ▶ Children should be supervised to ensure that they do not play with the massage chair. ▶ Do not fall into sleep while the product is operating. ▶ Avoid using the product under the influence of alcohol. ▶ Do not put hands or foreign objects in the openings of the appliance to avoid injury to the user or damage to the appliance. ▶ If there is any smoke or unusual smell during operation, stop using immediately.
 NO DISASSEMBLE	<ul style="list-style-type: none"> ▶ Do not disassemble this product to avoid failure. ▶ Do not attempt to repair or dismantle the appliance without permission. Please contact authorized dealer or service agent.
 UNPLUG POWER CORD	<ul style="list-style-type: none"> ▶ Pull out the power cord from the power strips before maintenance. ▶ Never plug in or pull out power cord with wet hand to avoid shock or injury. ▶ Pull out the power cord from the power strips after use. ▶ Unplug from outlet when the power supply is cut.

SAFETY PRECAUTIONS

Best Practices for Safe Use

 CAUTION	<ul style="list-style-type: none">▶ Do not cover the product with blankets to avoid accidents due to overheat.▶ The plug should match with the socket outlet. Do NOT use a power strip to avoid electric shock, short circuit or fire.▶ Do NOT use this product in areas of high concentrations of volatile compounds to avoid fire or damage to the product.▶ Do not use solvents rubbing alcohol to clean your product; Do not spray insecticides into the product.▶ Paralyzed people cannot use this product to avoid physical discomfort or injury.▶ Do NOT coil the power cable to avoid damaging, fire or short-circuit.▶ Users can't be naked while using the massage chair.▶ Do NOT sit on the footrest or armrest to avoid accident.▶ Do NOT use this product near heat, open flame or on heating floor.▶ No smoking in the massage chair to avoid fire.▶ Do NOT use the massage chair when you are wet to avoid electric shock.▶ It is not recommended to use the unit for more than 5 minutes for particular part of the body.▶ Continue to massage on the same part of body at 30 minutes intervals. Never operate this product if water or any foreign object enter into the product, or there is damage to the product.▶ Check the power switch before use to avoid accident.
--	--



NAME AND FUNCTION OF EACH COMPONENT

External Structure

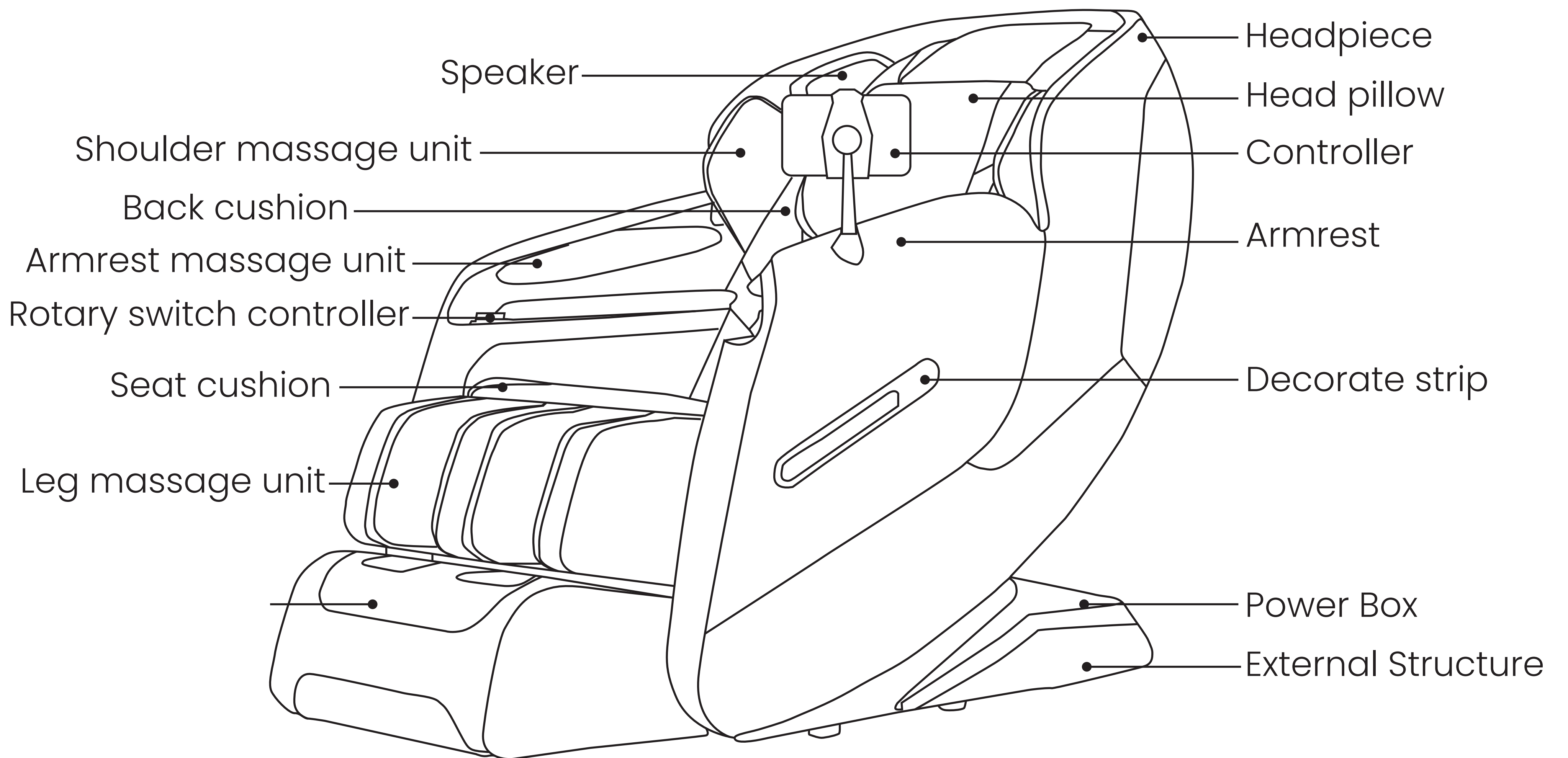

Internal Structure

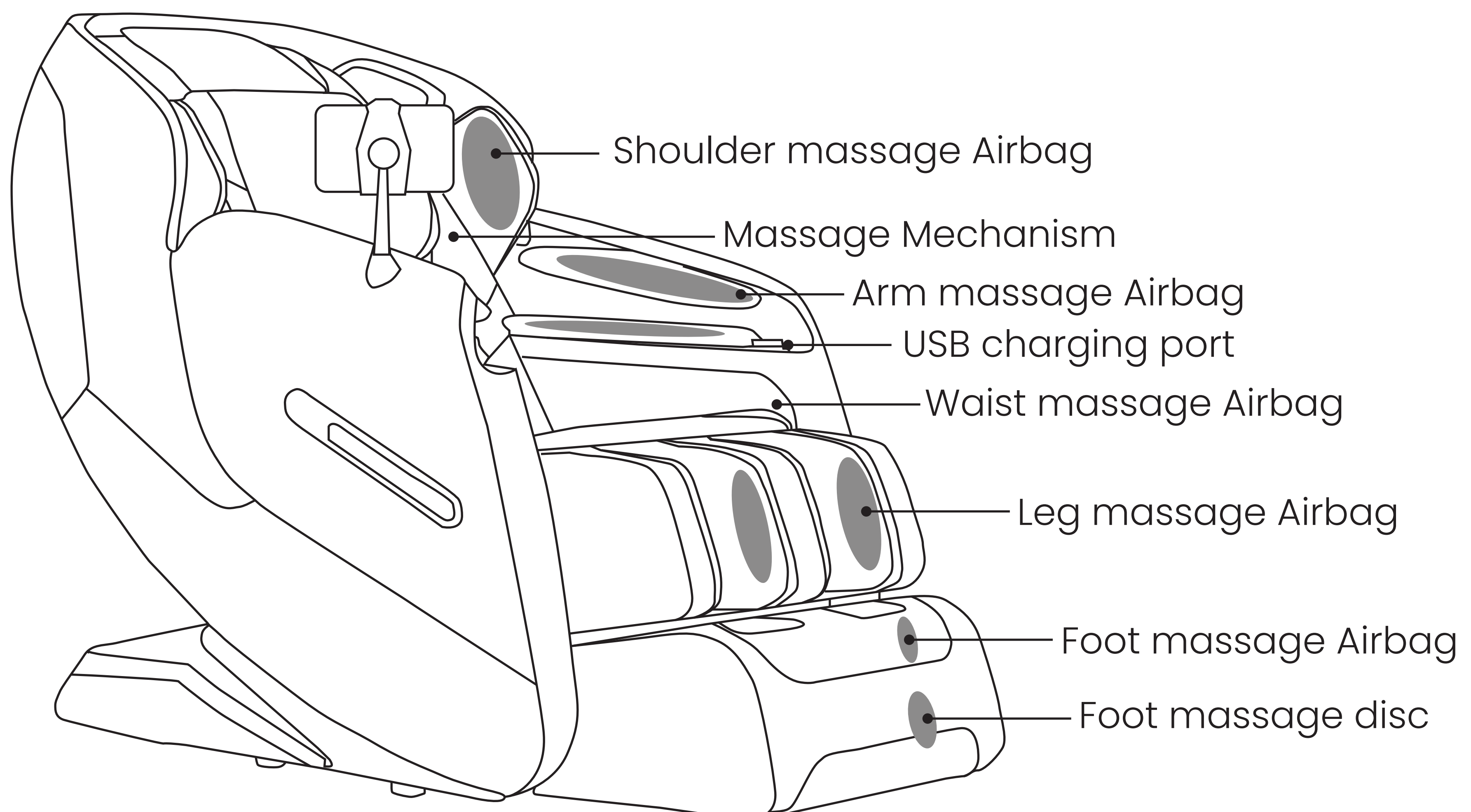

Note: When the massage chair is power on, the USB port can be used to charge personal devices (it can only be used as a charger).

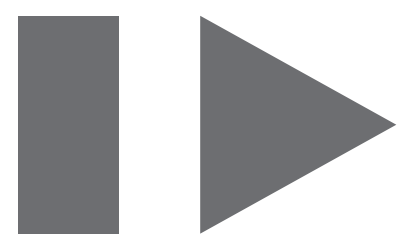

NAME AND FUNCTION OF EACH COMPONENT

Controller Screen

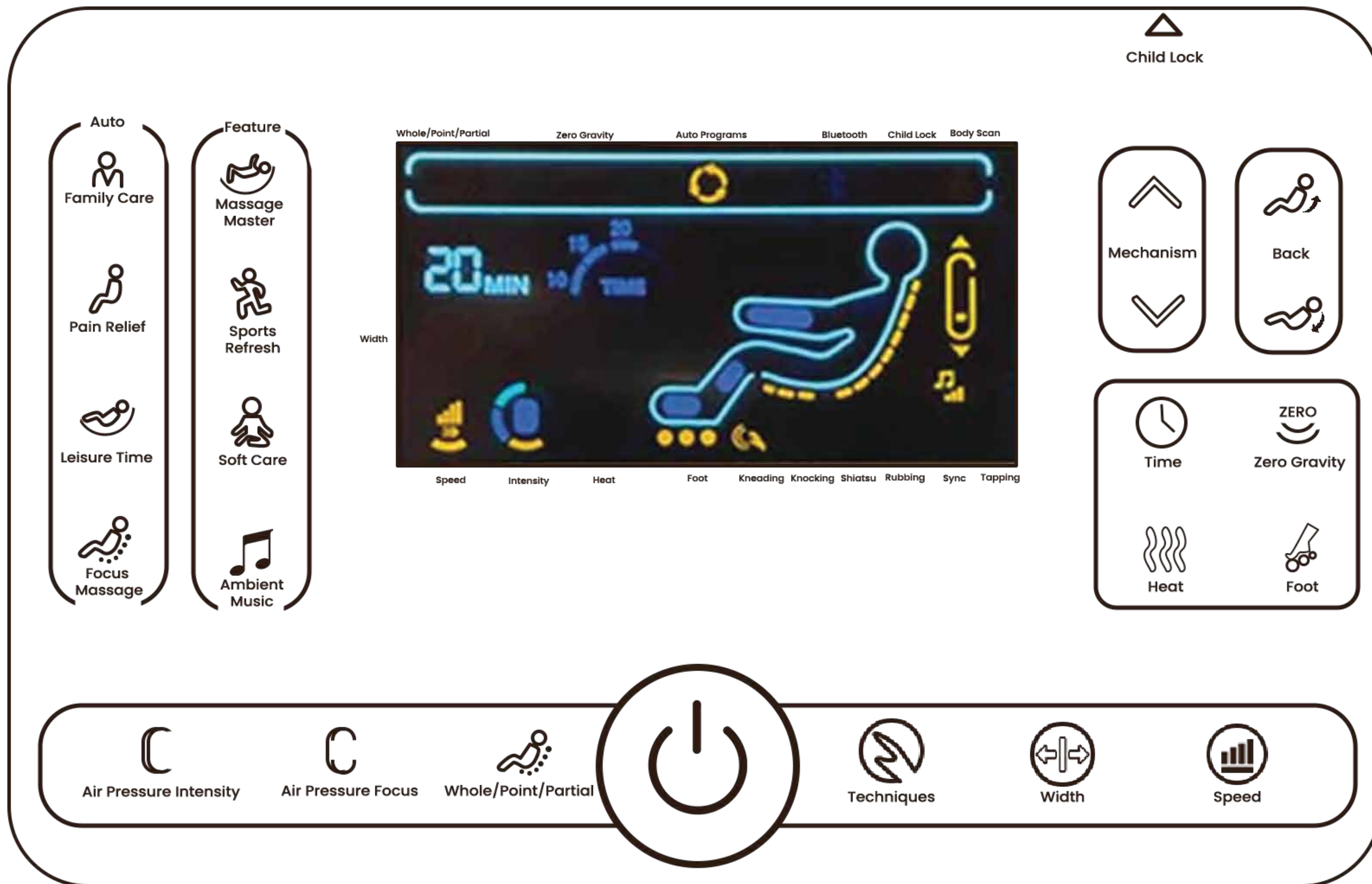

Controller Screen Instructions



Massage Master

With moderate intensity, Massage Master can effectively promote the recovery of body fatigue. Its exclusive massage techniques can help alleviate various discomfort such as sedentary neck, shoulder, waist and back pain. Combined with soft ambient music, it can help relax the mind and relieve fatigue.



Sports Refresh

Sports Refresh helps relax the whole body. It can effectively relieve muscle pain, neck, shoulder, back, waist, leg and other post-workout discomfort, stretch muscles and bones, relieve tired body and relax tight muscles.



Soft Care

Combined with rhythmic swing, this massage program helps to promote blood circulation and relax body and mind, effectively alleviate various discomfort caused by lack of sleep, such as body discomfort, lethargy, slow response, headache and poor memory. It can calm the mood and melt away tension.



Ambient Music

When an Auto massage program is running, short press this button to turn off Ambient Music (default setting: on), short press again to toggle among music volume 1, 2, 3 or off; long press this button to turn off/on voice guide.



NAME AND FUNCTION OF EACH COMPONENT

Auto Massage Programs



Family Care - Queen Slimming

A personal massage program to dote on ladies. It provides the custom tailored masseuse like relaxation in the comfort of your home.

Family Care - Man's Massage

A customized massage designed for the gentlemen. It uses featured massage techniques for the male users to relax and refresh the body and mind.

Family Care - Senior's Joy

A special massage program designed for the seniors. It uses super soft and slow massage techniques to help clear the meridians.



Pain Relief - Neck & Shoulder

It uses kneading, shiatsu, lift and pull massage techniques to ease the pain and stiffness in the neck and shoulders.

Pain Relief - Waist & Hip

This program targets the rollers at the deep tissue of waist and hips to soothe stiff muscles and melt away tension.

Pain Relief - Back & Spine

It uses a combination of deep tissue massage techniques and focuses on muscles along the spine, upper and lower back and lumbar.



Leisure Time - Game Mode

It is suitable for enjoying a massage in the leisure time to relieve tension.

Leisure Time - Coffee Mode

It is suitable for enjoying a massage when gathering with friends, taking coffee or having a chat.

Leisure Time - Nap Mode

It is suitable for mid day break to help soothe tension, improve digestion and refresh the body.



Focus Massage

Press this button to toggle among Neck Massage, Shoulder Massage, Back Massage, Waist Massage, Hip Massage and Leg Massage, indicator of the chosen part lights up and blinks.

Neck Massage: Neck Massage helps alleviate neck pains. The unique neck "kneading and shiatsu" and "lift and pull" techniques can effectively alleviate the fatigue and stiffness of the user.

Shoulder Massage: Shoulder Massage is designed for shoulder relief, it uses unique shoulder "kneading and knocking" technique to relieve fatigue and relieve shoulder pain.

Back Massage: Following the curve of the human body, this massage program uses combination of rolling, pushing and pressing massage techniques to help relieve fatigue.

Waist Massage: Using comfortable air pressing massage, combined with kneading massage and other techniques, Waist Massage can improve lumbar stiffness, alleviate lumbar fat accumulation and enhance lumbar flexibility.

Hip Massage: Sedentary lifestyle will cause poor blood circulation in the hip. Hip Massage can help improve blood circulation. Using kneading, shiatsu and sync massage techniques, it can shape and tone hip muscles.

Leg Massage: Customized kneading, knocking and tapping techniques can improve blood supply, improve recovery, encourage lymphatic drainage and reduce pain.



NAME AND FUNCTION OF EACH COMPONENT

Other Buttons



Power button:

Press and hold this button to power on/off the controller. Press and hold this button while connected to power to start the massage chair. It defaults to start Massage Master massage program. Auto body scan: Massage chair starts body scan automatically before massage, indicator lights up accordingly. Adjusting mechanism position: When the mechanism position up/down indicator lights up, you may press and hold the up/down button to adjust the massage rollers manually to conform to your shape for a unique personal massage. Press and hold this button again to turn off the massage chair. (The default massage timer is 20 minutes)



Air Pressure Level:

Press this button to adjust air pressure levels, you may toggle among level 1,2, 3,4,5 air pressure intensity settings, the indicator lights up/down accordingly.



Air pressure massage:

PART Press this button to choose air pressure massage, you may toggle among upper body air pressure, lower body air pressure, whole body air pressure, air pressure off, the indicator lights up/down accordingly.



Whole/Point/Partial:

Under manual massage mode, press this button to toggle among whole/point/partial massage mode. Full body massage: Massage mechanism travels up and down along the full back, hips and thighs, the indicator blinks accordingly. Point massage: Focus the massage on current point, you may move the mechanism up/down by pressing the mechanism up/down adjustment button, the indicator blinks accordingly. Partial massage: Focus the massage on current zone, you may move the mechanism up/down by pressing the mechanism up/down adjustment button, the indicator blinks accordingly.



Massage techniques:

Under manual mode, press this button to toggle among: kneading, knocking, shiatsu, rubbing, sync and tapping massage techniques, the indicator lights up accordingly.



Massage Width:

Under manual mode, press this button to toggle among wide, narrow, medium massage width, the indicator lights up accordingly. Width not adjustable in kneading, rubbing or sync massage mode.



Massage Speed:

Under manual mode, press this button to toggle among level 1,2,3,4,5 speed settings, the indicator lights up accordingly.



Time:

Press this button to toggle among 10 minutes, 15 minutes, 20 minutes, 25 minutes, 30 minutes massage timers.



NAME AND FUNCTION OF EACH COMPONENT



Zero Gravity:

Press this button to toggle among Zero Gravity position 1, Zero Gravity position 2, Zero Gravity position off.



Heating:

Press this button to choose heat settings, the indicator lights up/down accordingly. You may toggle among level 1,2,3, off heat settings.



Sole:

Press this button to toggle among level 1,2,3, off sole massage settings.

Mechanism Up/Down:



Press and hold mechanism up/down button to move the mechanism to desired positions, the indicator lights up/down accordingly. Press and hold mechanism up/down button to adjust the rollers to the desired position while in Auto program body scan procedure.



Back up:

Press and hold to raise the backrest; release the button to stop.



Back down:

Press and hold to recline the backrest; release the button to stop.



Child Lock:

Child lock defaults to on when massage chair is connected to power, controller is locked and won't work. Press and hold this button for 5 seconds to unlock/lock the controller. The indicator lights up/down accordingly.

Rotary switch controller

Long press power button to switch on/off the power; short press power button to toggle auto programs, rotate this switch to raise/recline the backrest.

VOICE FUNCTION

Voice Activation

- ▶ Language Support: English
- ▶ Voice device can be activated by saying to the microphone "Hello, Hello". Say the following command will restart the massage chair when massage chair is shutting down.
- ▶ Voice Activation Command:

Order Entry	Answer
Hello, Hello	Please say voice command
Power on	OK, Power on
Power off	OK, Power off
Massage Master	OK, Massage Master
Sports Refresh	OK, Sports Refresh
Soft Care	OK, Soft Care
Family Care	OK, Family Care
Pain Relief	OK, Pain Relief
Leisure Time	OK, Leisure Time
Focus Massage	OK, Focus Massage
Change a program	OK, Change a program
Music on	OK, Music on
Music off	OK, Music off
Sole massage on	OK, Sole massage on
Sole massage off	OK, Sole massage off

VOICE GUIDE FUNCTION

Voice Guide Function

- ▶ There is voice guide prompted with each operation of massage chair.
- ▶ Voice Guide :

Controller Button	Voice Guide
Power on/Power off	Power on/Power off
Massage Master	Massage Master
Sports Refresh	Sports Refresh
Soft Care	Soft Care
Ambient Music	Music off, Voice guide off
Family Care	Queen Slimming, Man's Massage, Senior's Joy
Pain Relief	Neck & Shoulder, Waist & Hip, Back & Spine
Leisure Time	Game Mode, Coffee Mode, Nap Mode
Focus Massage	Neck Massage, Shoulder Massage, Back Massage, Waist Massage, Hip Massage, Leg Massage
Mechanism Up/Down	Mechanism up, Mechanism down
Back Up/Down	Back up, back down
Time	10 min, 15 min, 20 min, 25 min, 30 min
Zero Gravity	Zero Gravity position 1 & 2, Zero Gravity off
Heat	Heat level 1, Heat level 2, Heat level 3, Heat off
Sole(Manual control)	Roller speed level 1-3, Roller off
Massage Width	Wide, narrow, medium
Massage Speed	Speed level 1-5
Massage techniques	Kneading, knocking, shiatsu, rubbing, sync, tapping
Whole/Point/Partial	Full body massage, Point massage, Partial massage
Air pressure massage	Upper body air pressure, lower body air pressure, whole body air pressure, air pressure off
Air pressure level	Air pressure level 1-5
Shoulder scan	Shoulder scanning
Shoulder position adjusting(manually)	You may move the mechanism up/down by pressing the mechanism up/down adjustment button

FUNCTIONS AND FEATURES

1. Sliding and Reclining

It can Slide and recline to save space and provide utmost relaxing position.

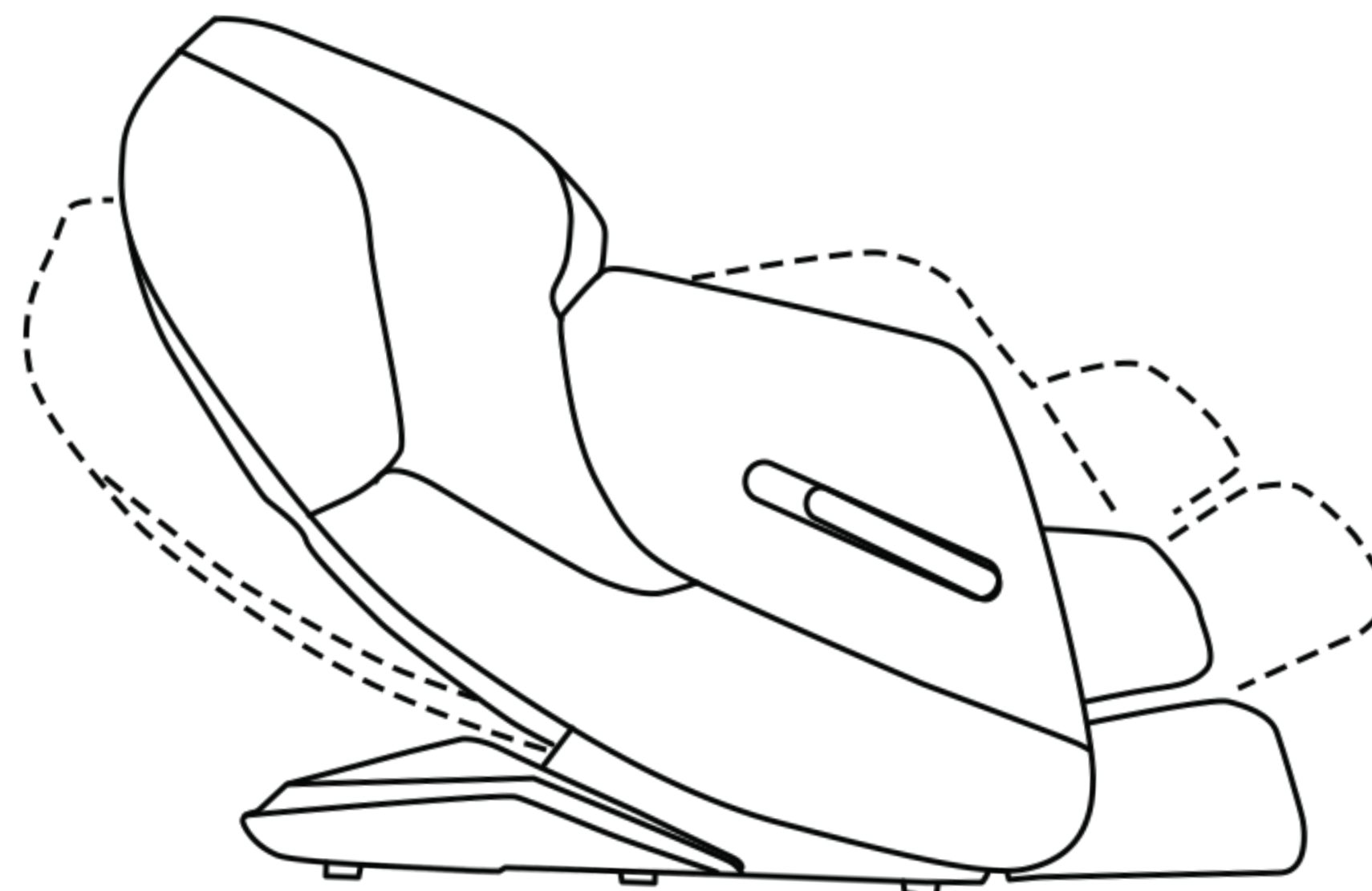
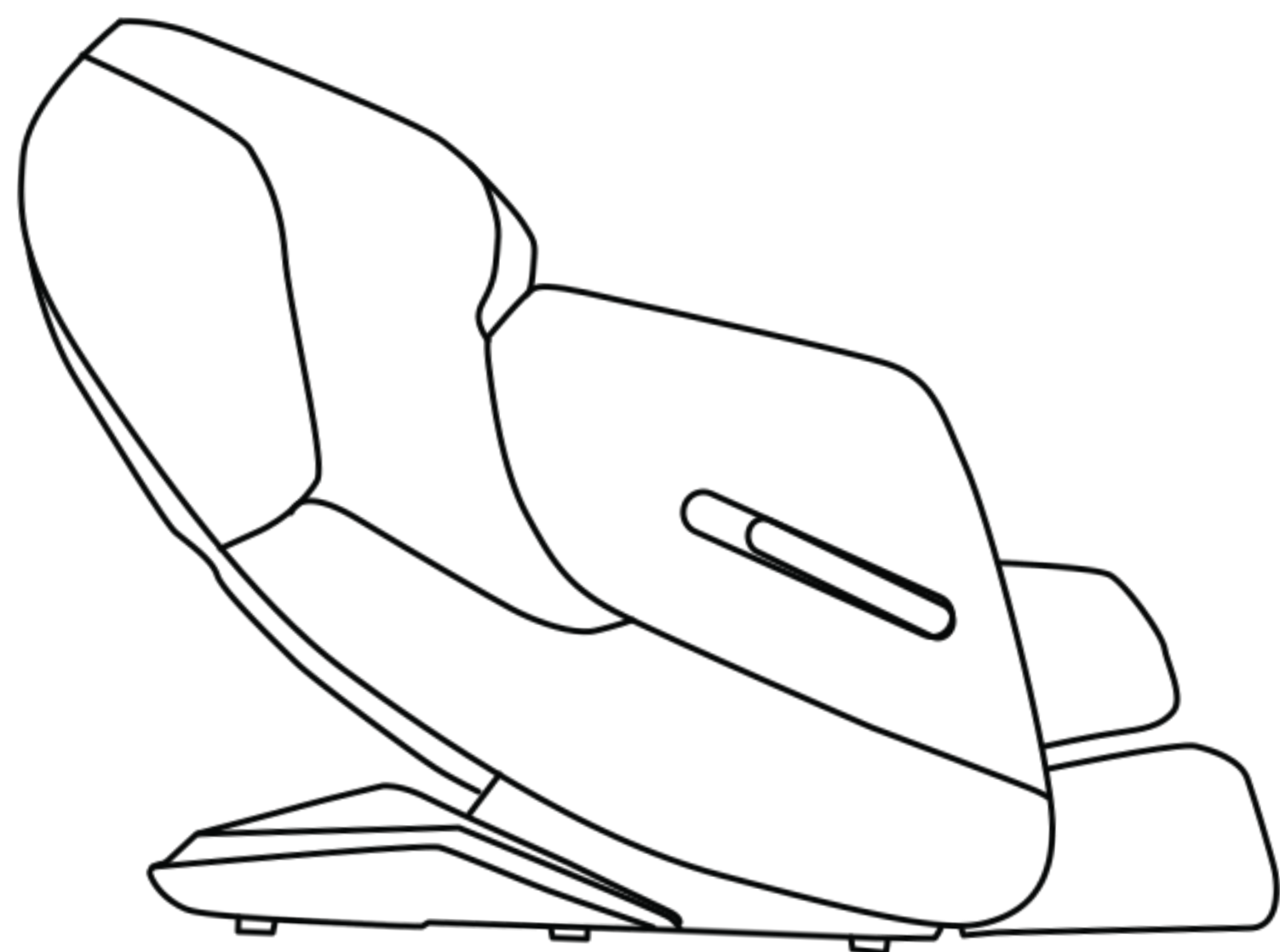

2. 3D Mechanism

3D mechanism can crane forward by 5CM to ensure a deeper relief of stress and pain in the neck, shoulder and waist muscles.

3. Auto Extension Legrest

Legrest can extend by maximum 26cm automatically, fulfilling the need of diversified statures. The footrest can extend by 16cm for various users of different height ranges.

4. Air Pressure Massage

36 Air bags provide right and comforting air pressure massage for shoulders, arms, waist, legs and feet.

5. Large Foot Massage Disc

Two bumpy discs provide hand simulation rolling and shiatsu massage for the foot reflex zone.

6. Manual massage programs

Mimic human hand Kneading, Tapping, Knocking, Shiatsu, Sync, and Rubbing massage techniques for custom-tailored relaxation.

7. Simple and Easy-to-Use Controller

Simple and easy-to-use controller provide easy access to all functions.

8. Voice Control

You can turn on/off the massage chair, start/switch auto or manual programs by speaking the command, which frees your hands and allows head to toe rest.

9. Super Long SL-Style 6-Section Track

Intelligent body scanning proving accurate targeting massage for neck, shoulders, back, waist, hips and legs.

▶ PRELIMINARY CHECKS

Unpacking Massage Chair Cartons

- ▶ Unpack the carton and take all massage chair units out of the carton.

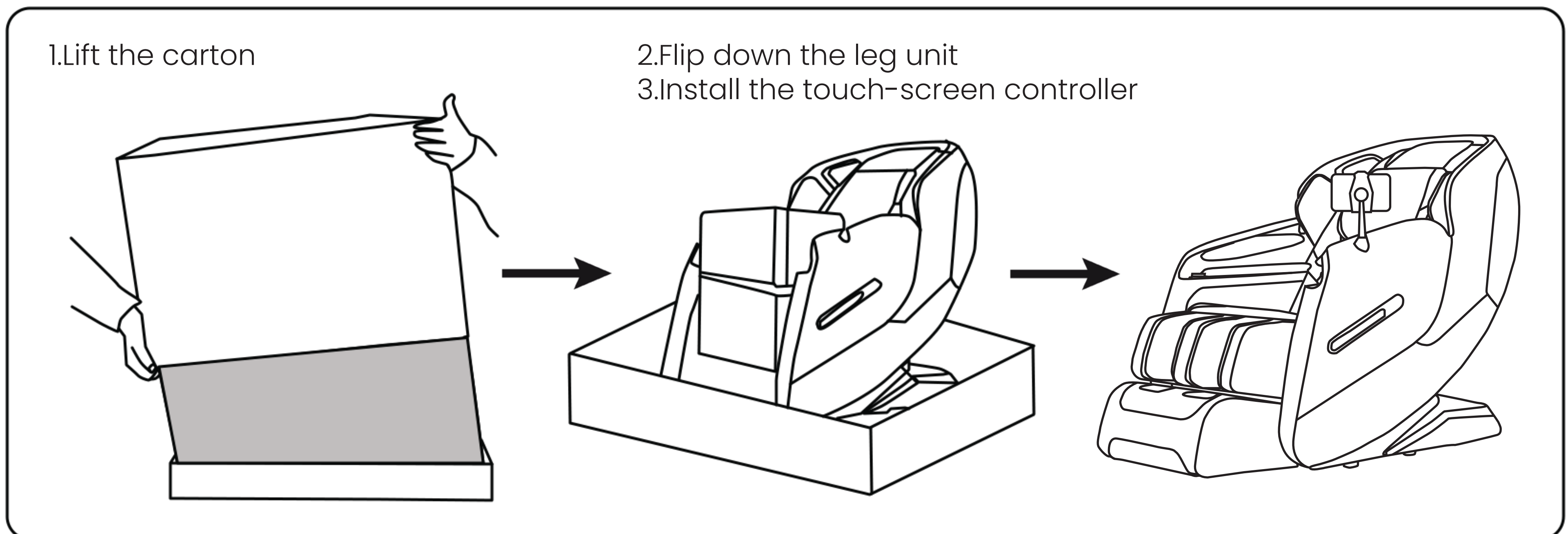

- ▶ Remove secure straps and lift the carton vertically, flip down the leg unit.
- ▶ Take out the user manual, power cable, touch screen controller and controller stand.
- ▶ Remove the rubber tip, insert the lower end of controller stand into the socket and turn clockwise to secure the stand into place, connect the controller connectors.
- ▶ Plug the power cord into the chair and connect to the power outlet, turn on the main power switch, you are set to go. (check below fig.)

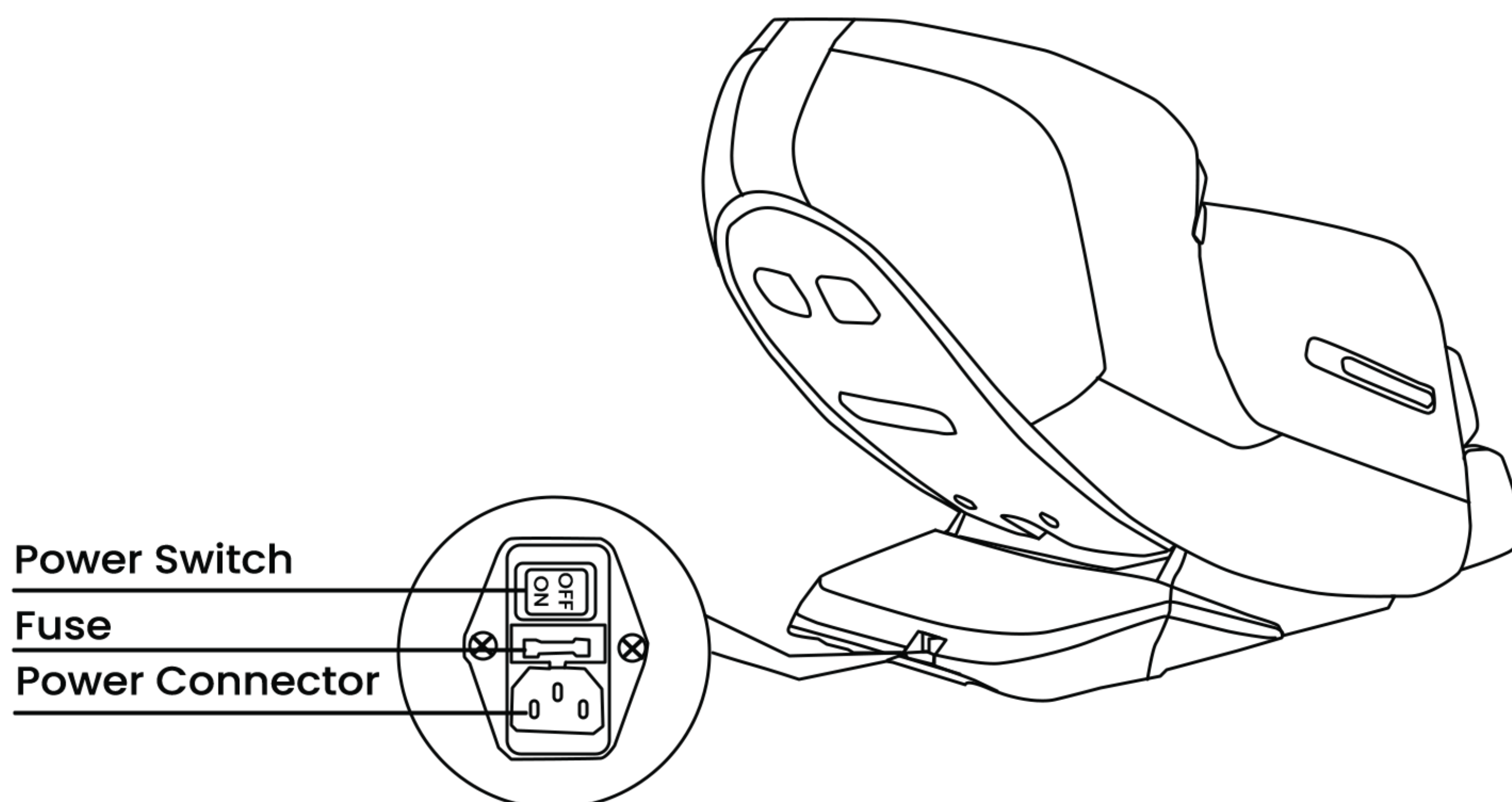

⚠ CAUTION

- ▶ Do not disassemble this product yourself to avoid product failure.
- ▶ Make sure no water or other liquid enters into the controller to avoid fault.
- ▶ Do not pinch or squeeze the controller or power cord.

▶ PRELIMINARY CHECKS

Moving the Massage Chair

- ▶ Roll the chair on its casters to the desired location.
- ▶ Incline the backrest to upright position.
- ▶ Turn off the power switch and unplug the appliance from the electrical outlet.
- ▶ Using two people, push down on the backrest and lift up on the front side by grabbing the moving Holder located to the front bottom of the armrest), roll the chair on its casters to the desired location(check the sketch for reference).

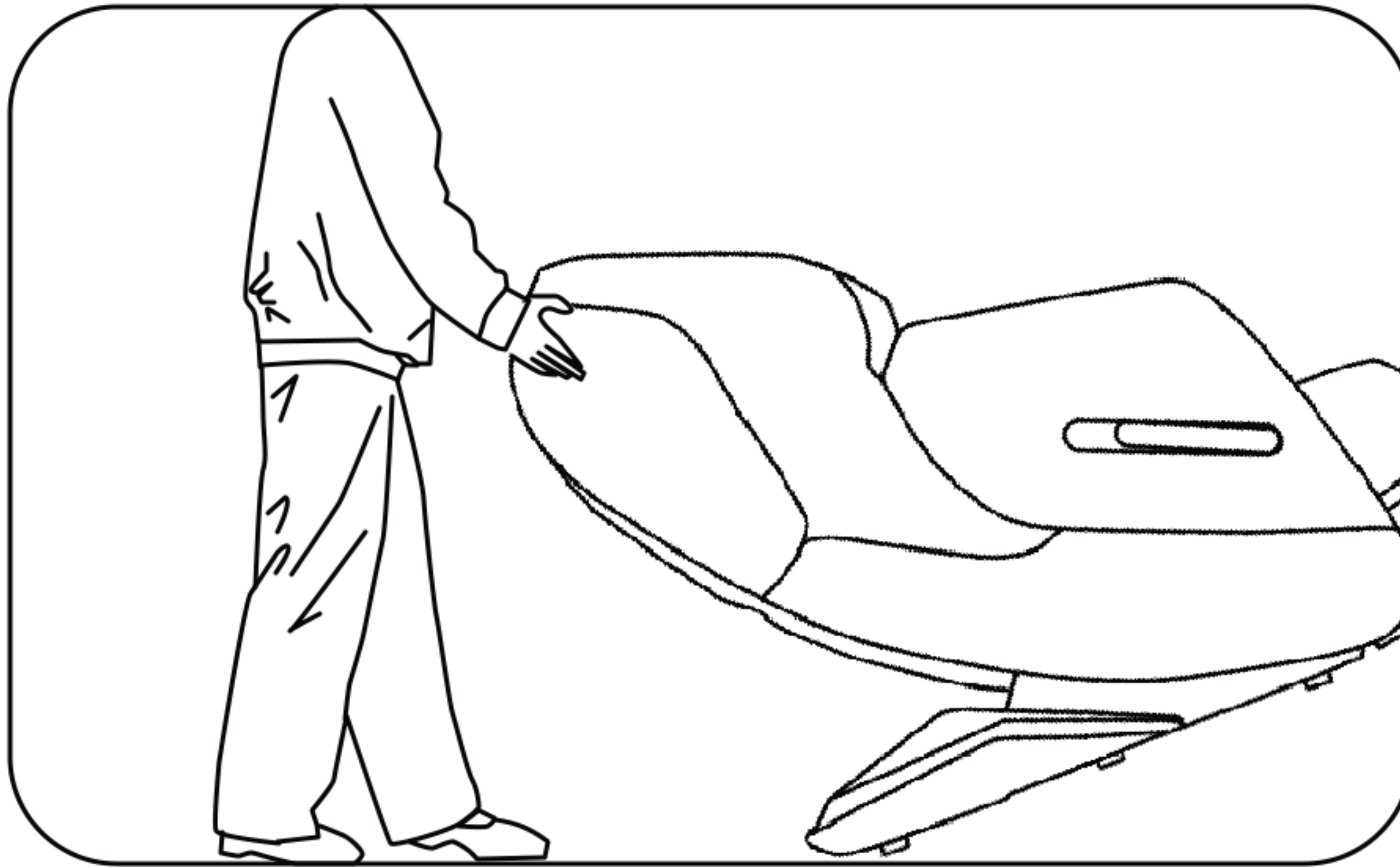

⚠ CAUTION

- ▶ Do not move the chair when there is user inside.
- ▶ To carry this product, do not lift by the footrest or armrest, hold the chassis and steady the backrest(have 4 or more people to carry the product).
- ▶ The massage chair is heavy, be careful when moving it.
- ▶ Please contact the dealer if you need help of moving the massage chair.

Connecting to Power

- ▶ Connect this appliance to a 3-wire properly grounded outlet.
- ▶ Turn on the power switch located at the back of power box.

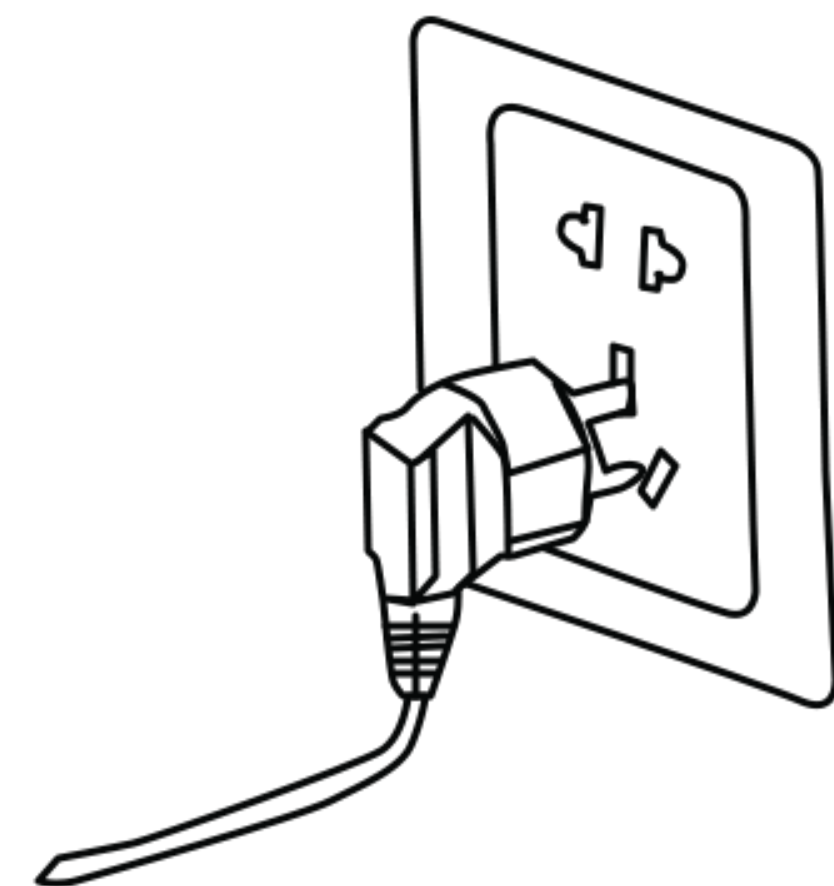

⚠ CAUTION

- ▶ Please verify that there is no damage to the supply cord before switching on the massage chair.
- ▶ Please verify that the main power switch is turned off before connecting to power.

▶ PRELIMINARY CHECKS

Clearance space for the massage chair:

- ▶ Ensure there is an adequate clearance for the installation: It needs 16cm clearance for the reclining of the backrest; It needs 30cm clearance space for the extension of footrest and sliding forward of the chair.
- ▶ Keep it 1 meter away from the TV, radio or other audio/video appliance to avoid signal interference.

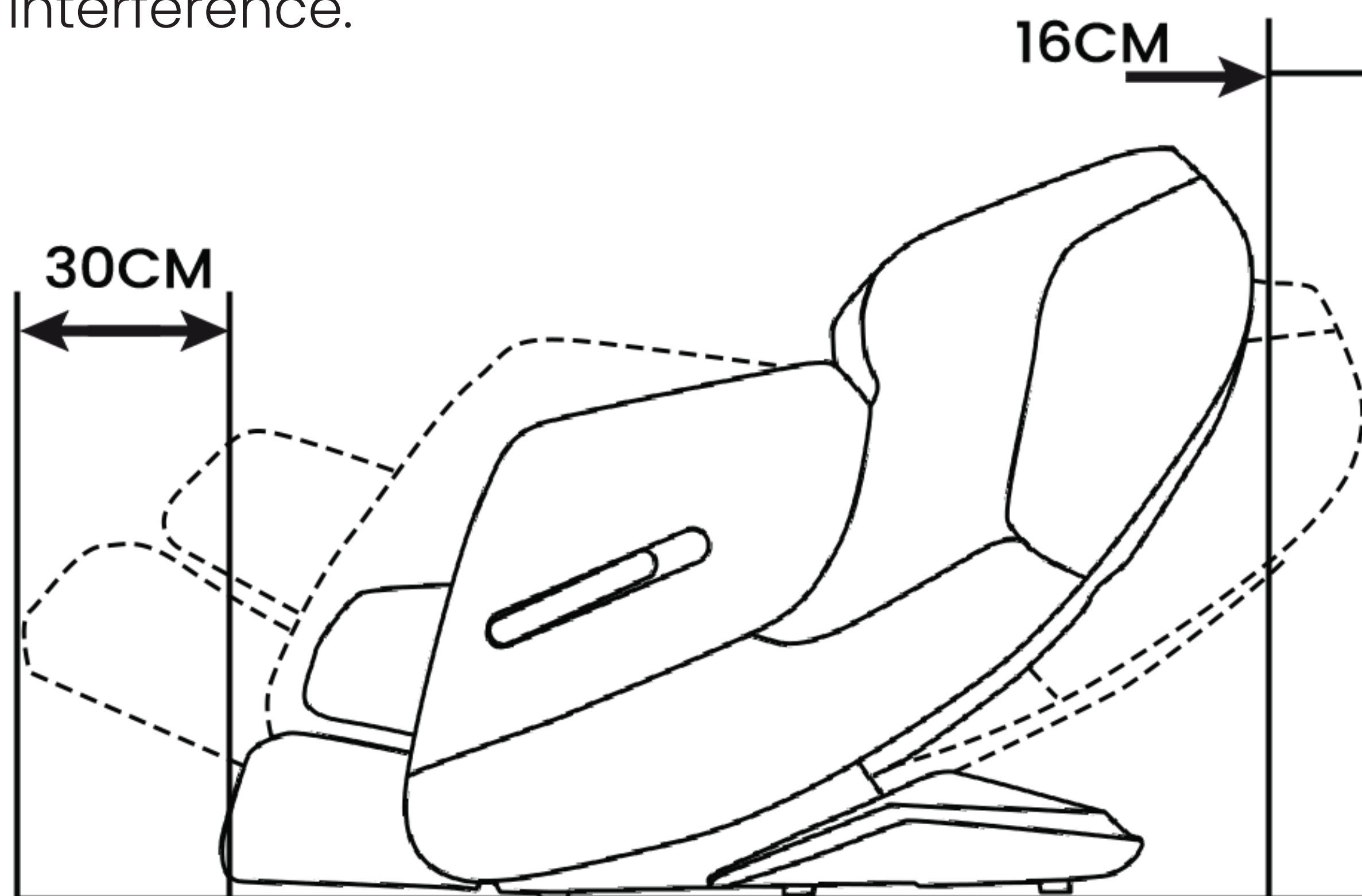

- ▶ Keep the distance between the power socket and power switch within 1.5 meter.

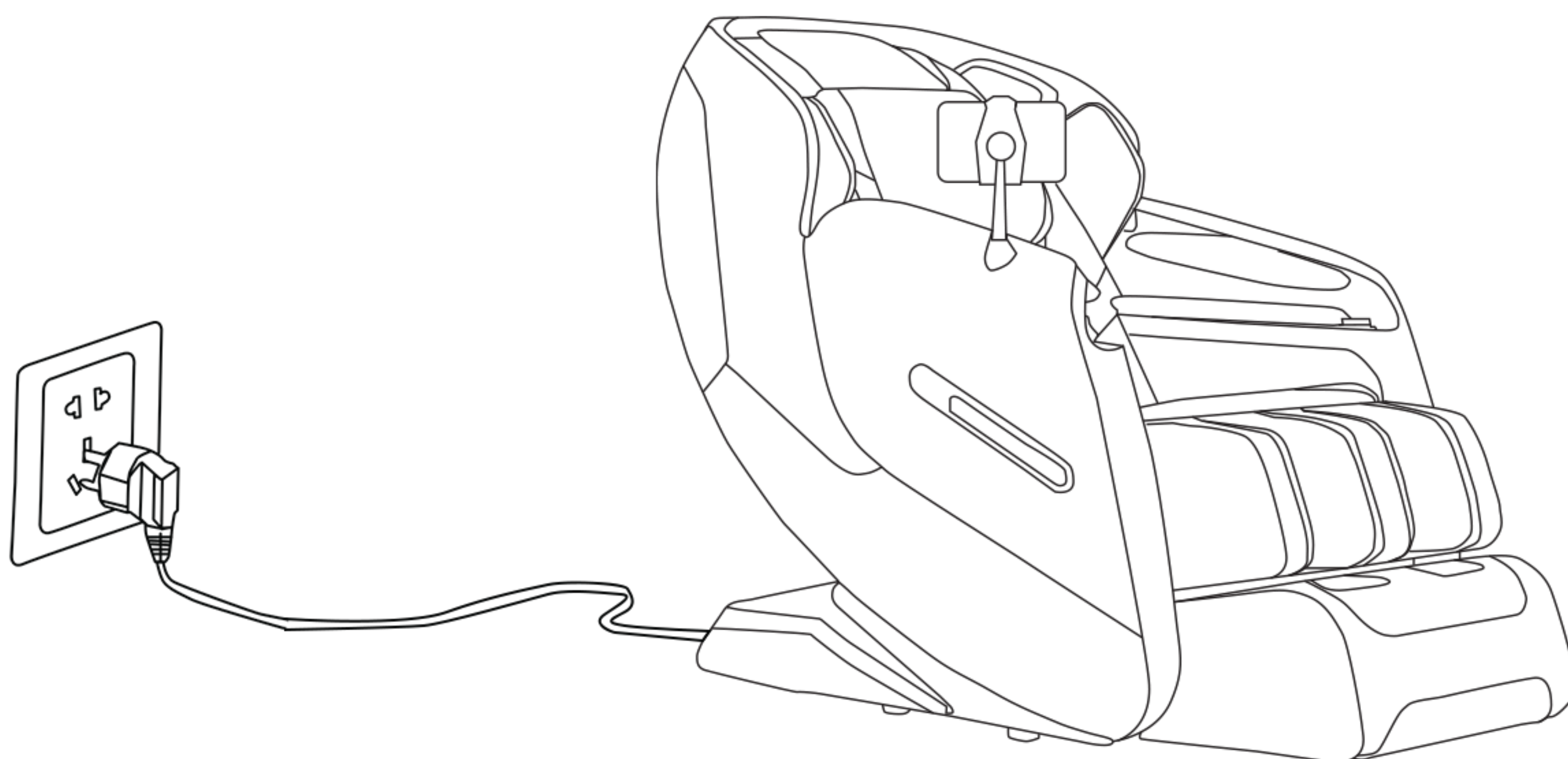

⚠ CAUTION

- ▶ Keep the distance between the power socket and power switch within 1.5m to avoid damage of power cord while massage chair sliding forward.
- ▶ Straighten the power cord while in use to avoid tangle or damage.
- ▶ When the massage chair sliding forwards or back, please check to make sure there are no children, pets or other obstacles around to avoid accident.

PRELIMINARY CHECKS

Floor Protection

- ▶ Before use, we recommend placing a piece of carpet or soft mat underneath it to avoid damaging the floor.

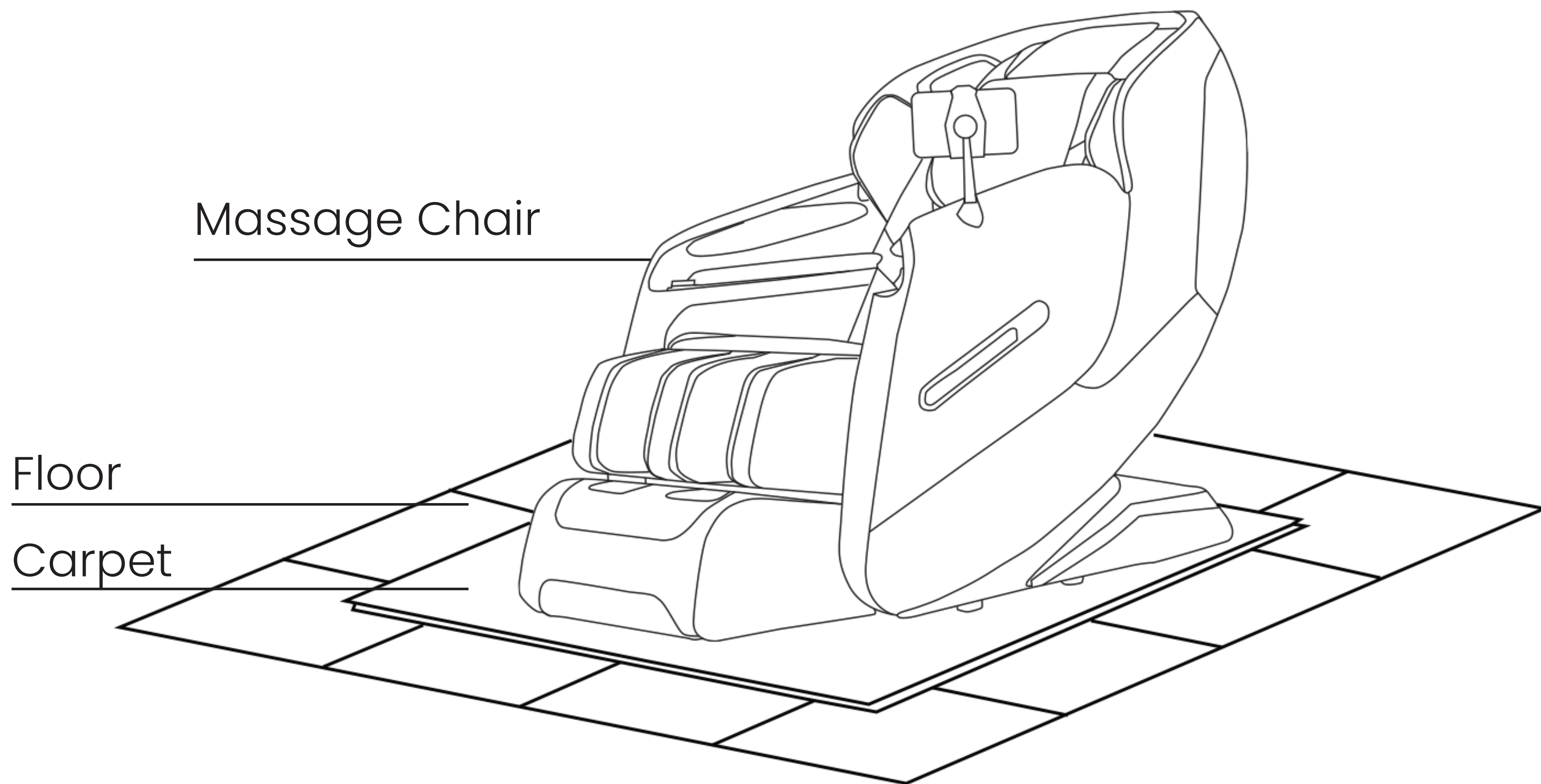

Surrounding Environment



Do not use the massage chair in high moisture environment such as near swimming pool or bathroom to prevent electric shock accident.

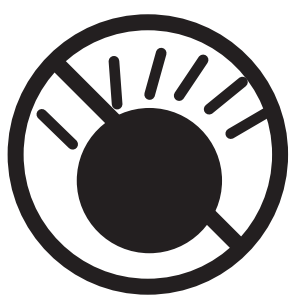

Please keep the massage chair away from heated surfaces to prevent fire hazard or damage to the product.

Grounding



This product must be grounded, the plug must be plugged into an appropriate 3-wire grounded outlet that is properly installed and grounded in accordance with all local codes and ordinances to reduce risk of electric shock.

▶ PRELIMINARY CHECKS

- ▶ Use the controller to recline the backrest to its lowest position, raise and extend the footrest to its top position, make sure there is enough clearance before commissioning.
- ▶ Return the backrest and footrest back to its default position after commissioning and turn off the power switch.
To choose the massage program, please check the Instructions of Controller and Instructions of Display Screen for reference.

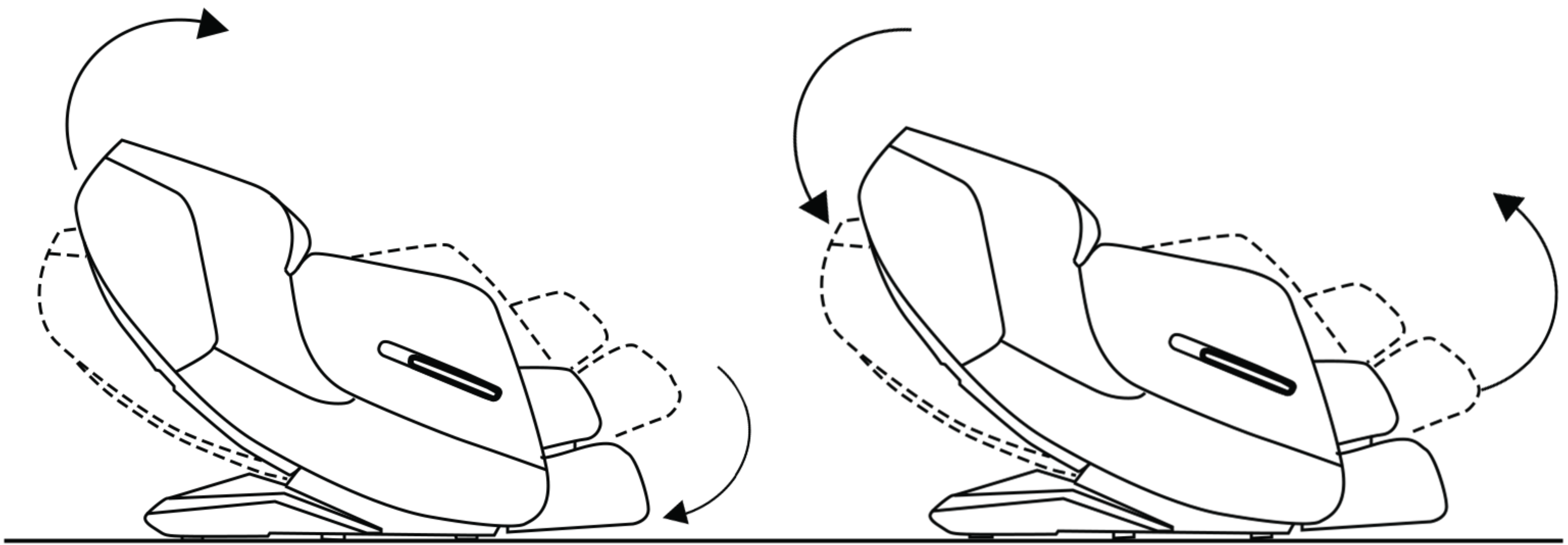

Before Sitting in the Chair

- ▶ Ensure the footrest is well assembled before sitting on the massage chair.
- ▶ Ensure the massage chair is returned to its original position before sitting on it.
- ▶ If there is any part not in default position, please turn off the massage chair to allow it to restore.



CAUTION

- ▶ Do not take seat while the legrest is lifted.
- ▶ Do not put excessive load on the legrest to avoid damage.

▶ PRELIMINARY CHECKS

Feet Extension

- ▶ Step your feet on the footrest to extend the footrest to the length you desire for better massage experience.

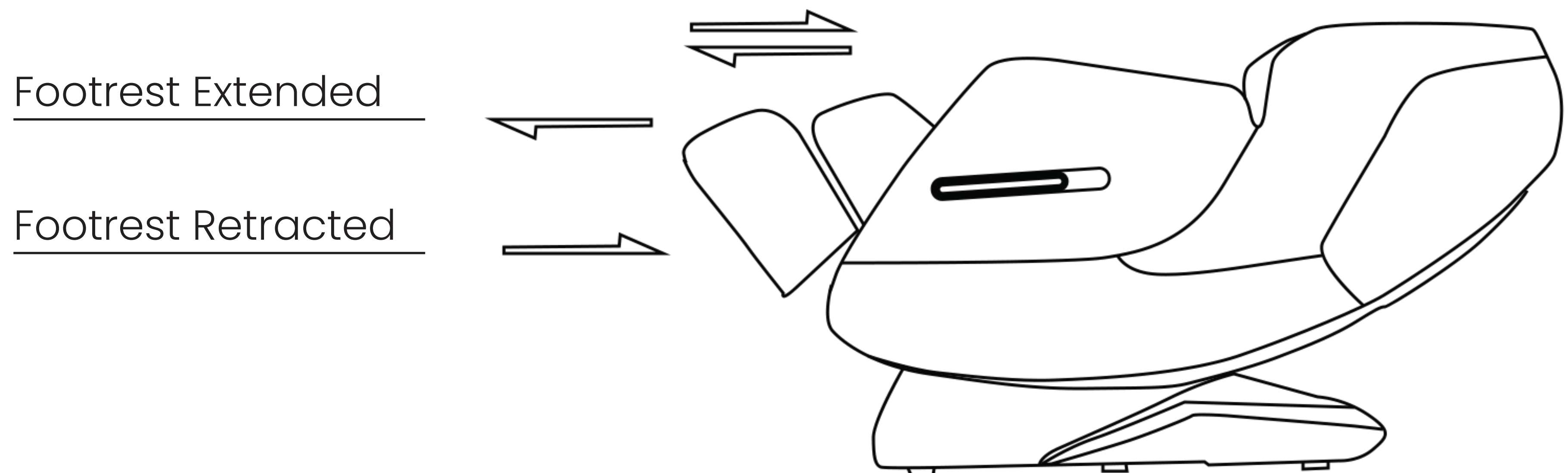

- ▶ You may retract the footrest to the length you desire for better massage experience.

! WARNING

- ▶ Do not play on the massage chair or operate it improperly.
- ▶ Ensure there is no obstruction when raising or reclining the backrest and footrest.
- ▶ Do not put foot, fingers or any other objects in the openings of the chair when it is in the reclining, raising or restoring motion.
- ▶ Ensure that massage chair is restored back to its original position before getting off the massage chair.

Audio Function

- ▶ To play sound, turn on Bluetooth on your Android/Apple iOS device and place the massage chair in discovery mode to pair(Name:A50).

After Use

- ▶ Always unplug the massage chair from the electrical outlet immediately after use.
- ▶ Turn off the power switch and unplug the massage chair from the electrical outlet while not in use to avoid children power on the massage chair accidentally.
- ▶ When not in use for a long period of time, we recommend that the chair be covered, the power cord be coiled and that the unit be placed in an environment free of dust and moisture.

PRODUCT STORAGE AND MAINTENANCE

Care Instructions



- ▶ To treat stains on controller, power box, spot clean with a dry cleaning cloth.
- ▶ To treat stains on back cushion or pillows, use a water-based upholstery cleaner only, wipe it with moist cloth, then air dry.
- ▶ To clean the foot/calf unit covers, remove it from the chair, hand wash with a mild detergent, then line dry.



WARNING

- ▶ Children shall not play with the appliance. Cleaning and user maintenanceshall not be made by children without supervision.
- ▶ Pull out the power cord from the power strips before care and maintenance.
- ▶ To avoid electrical shock or injury, do not touch the power cord with wet hands.
- ▶ Make sure no detergent enter into the power box while cleaning.
- ▶ Do not use benzene, thinner or other solvents on your product, it may cause fading or damage to the product.
- ▶ Do not iron the upholstery.

Storage Methods

- ▶ Cover the product with a dust-free cloth to prevent collection of dust if not in use of a long period of time.



CAUTION

- ▶ Do not leave this product exposed to direct sunlight for long periods of time. This may cause fading or damage.

Warm Tips

- ▶ Burnt smell.
- ▶ Power flickers on and off when touching the charging cable.
- ▶ The power cord is hot.
- ▶ Other abnormal symptoms.



CAUTION

- ▶ Please stop using the product to avoid breakdowns or accidents if any above symptom exists.
- ▶ Switch off the power button and disconnect the plug, contact the local distributors or supplier for repair.
- ▶ All other servicing except above care and maintenance should be serviced by an authorized dealer or service center.



WARNING

Pull out the power cord from the power strips before care and maintenance. To avoid electrical shock or injury is the power cord with wet hands. Do not try to dismantle or repair the product yourself, please send your massage chair to the authorized service center.

TROUBLESHOOTING

NO.	Symptoms	Possible Causes	
1	Noise is heard while in use	This sound is normal and comes from the air compressor motor or other mechanical parts rubbing against the cloth cover	No need to take any measures
2	Appliance does not start	The power cord is not secured into the socket	Secure it into a well functioned electrical outlet
		Power switch is off	Turn on the switch
		The fuse is blown	Replace only with a fuse of same type and rating
3	Backrest or footrest can not raise or recline	Excessive load has been pressed on the backrest or legrest	Reduce the load and try again
4	Airbag malfunction	The air hose is blocked	Straighten the air hose and clear out the blockage
5	No music comes from the speaker	The volume is turned to the lowest	Adjust the speaker volume from the mobile devices
6	Massager stops working while in use	Massage chair is experiencing too much pressure	Slightly lift your back/backrest

Important: Do not attempt to repair this product yourself, our company shall not be liable for the injury or damage caused by any servicing without authorization. Thank you for your cooperation.

TECHNICAL SPECIFICATION

Product name: Shiatsu Master Massage Chair
 Model: A50
 Rated voltage: 220V~
 Rated frequency: 50HZ
 Rated power: 100W
 Safety design: Class I