

ROTAI ULTIMATE (Dual-Core) RT8900

User Manual

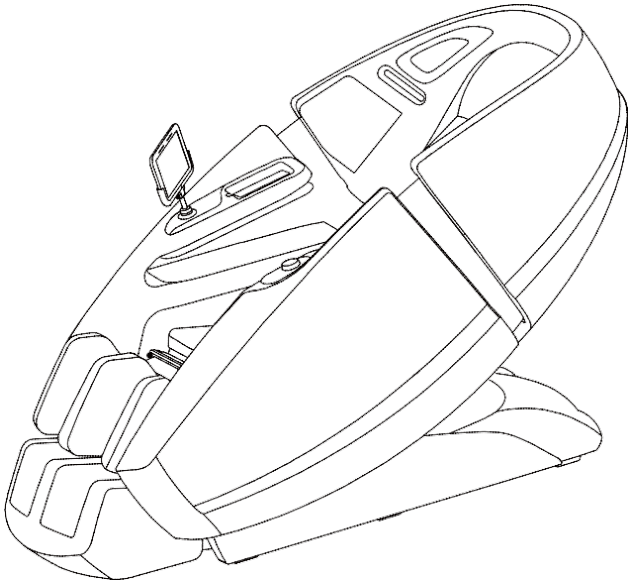

Thank you for purchasing what we believe to be the best massage chair currently in world wide production.

Please read this user manual carefully before using the RT8900 to ensure proper installation and operation.

Please keep this USER MANUAL for future reference.

CONTENTS

SAFETY PRECAUTIONS	3
NAME AND FUNCTION OF EACH COMPONENT	5
External Structure	5
Internal Structure	5
Quick Control Buttons	6
Instructions of Quick Control Buttons	7
Touch screen Controller Instructions	7
FEATURES	8
PRELIMINARY CHECKS	9
Installation Methods	9
Installation Site	12
Floor Protection	12
Moving Methods	14
Connect to Power	14
Commissioning	15
Inspections Before Sitting	15
Leg Extends/Retracts	16
After Operation	16
CARE AND MAINTENANCE	17
TROUBLE SHOOTING	18
PRODUCT SPECIFICATIONS	18

SAFETY PRECAUTIONS

- Precautions listed below will help to ensure proper use of this appliance.
- This chair must be plugged into a power point with RCD (residual current device) protection for the electrical warranty on this appliance to be valid. If your fuse box is not RCD protected then the plug must be used in combination with a BS approved RCD plug.
- The hazards that maybe caused by incorrect use are classified into "WARNING" and "CAUTION". Please ensure that you read all instructions before using the massage chair.



Improper operation may cause severe personal injury or substantial property damage.



Improper operation may cause personal injury or product damage.



Prohibited



Not to be Disassembled

List of Unsuitable Users



Please note the following guidelines & take medical advice accordingly before using the chair.

- **IMPORTANT:** The maximum clothed bodyweight limit for this chair is 120kg (19 stone). Any weight heavier than this is likely to cause damage to the chair's mechanism, which will not fall under Warranty.
- Those who have electronic medical instruments embedded in their body, such as a pacemaker.
- Those undergoing medical treatment or not feeling well.
- Those with malignant tumours or malignant abscesses. (Use with caution)
- Women who are pregnant.
- Those with osteoporosis or a fractured spine.
- Those with either skin disease or damaged skin.
- Those with high fever.
- Close supervision is necessary when this chair is used by, on, or near children, or disabled persons.
- The chair can have a heated surface. Persons sensitive to heat must be careful when using the chair.
- This chair should only be used by persons age of 16yrs or above. Persons with reduced physical, sensory or mental capabilities must be supervised by an adult at all times when using this chair to prevent accidents / injury.
- Children should not play with this chair.
- Cleaning and user maintenance must not be carried out by persons under the age 16yrs.

Control Buttons Precautions



- Do not operate the control buttons with wet hands.
- Do not spill liquids onto the control buttons to avoid electrical injury.

Cautions Regarding the Adapters and Cord



- Always unplug this chair from the electrical outlet immediately after using and before cleaning.
- The chair should never be left unattended when plugged in. Unplug from outlet when not in use. Unplug from outlet during thunder or lightning storms, and before changing any parts.
- Never operate this chair if it has a damaged cord or plug; if it is not working properly; if it has been dropped or damaged or dropped into water. Return the chair to the service centre for examination and repair.
- Check that the power voltage stated on the rating label corresponds to the UK electricity supply.
- Do not use wet hands to unplug the cord to avoid an electric shock. Do not pull the power cord to unplug the chair.
- Do not bend or twist the cord.
- Keep the cord away from heated surfaces.
- To disconnect, ensure the red power button on the back of the unit is in the “off position” and remove the plug from the outlet.
- The chair is only to be used with the power supply unit provided with the appliance.
- The chair must only be used with a 230v/50hz power supply.
- If the supply cord is damaged, it must be replaced by the manufacturer or its service agent or a qualified person in order to avoid an electrical hazard.

NAME AND FUNCTION OF EACH COMPONENT

External Structure

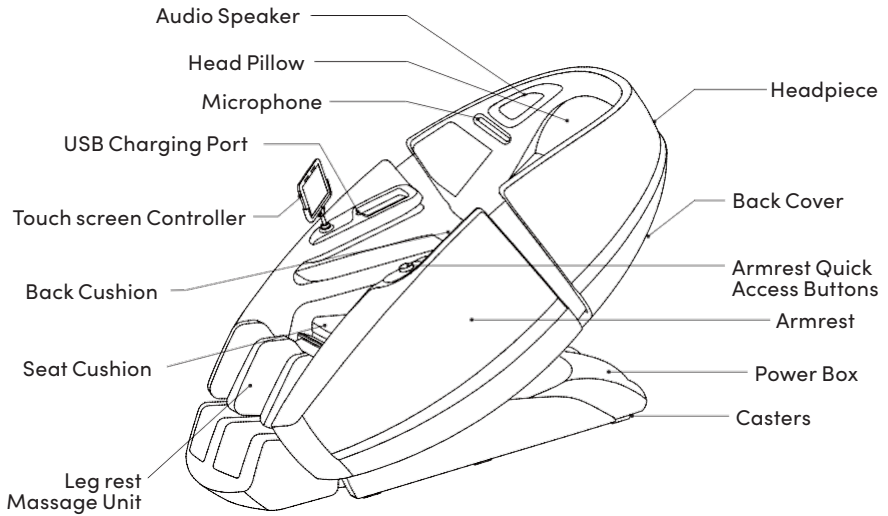

Internal Structure

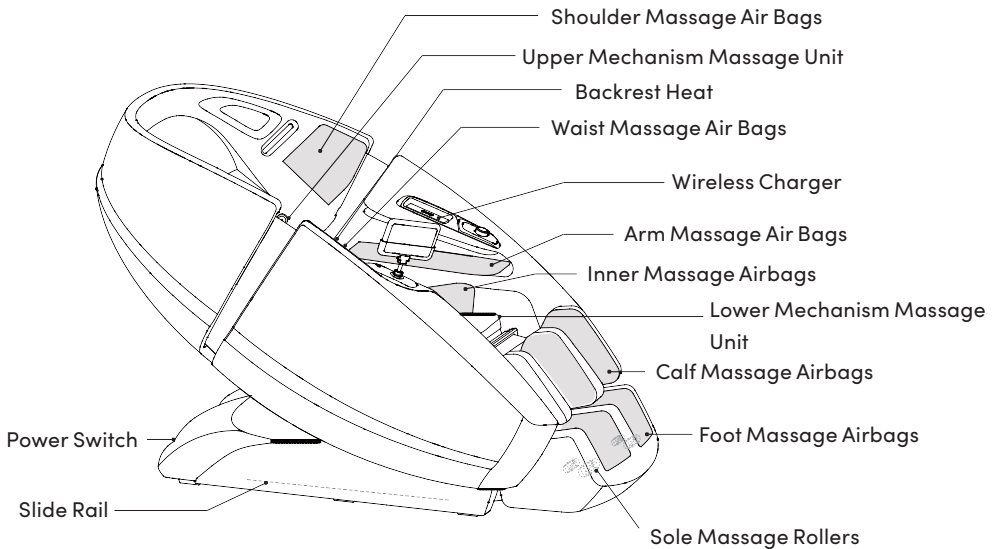

NAME AND FUNCTION OF EACH COMPONENT

Quick Control Buttons

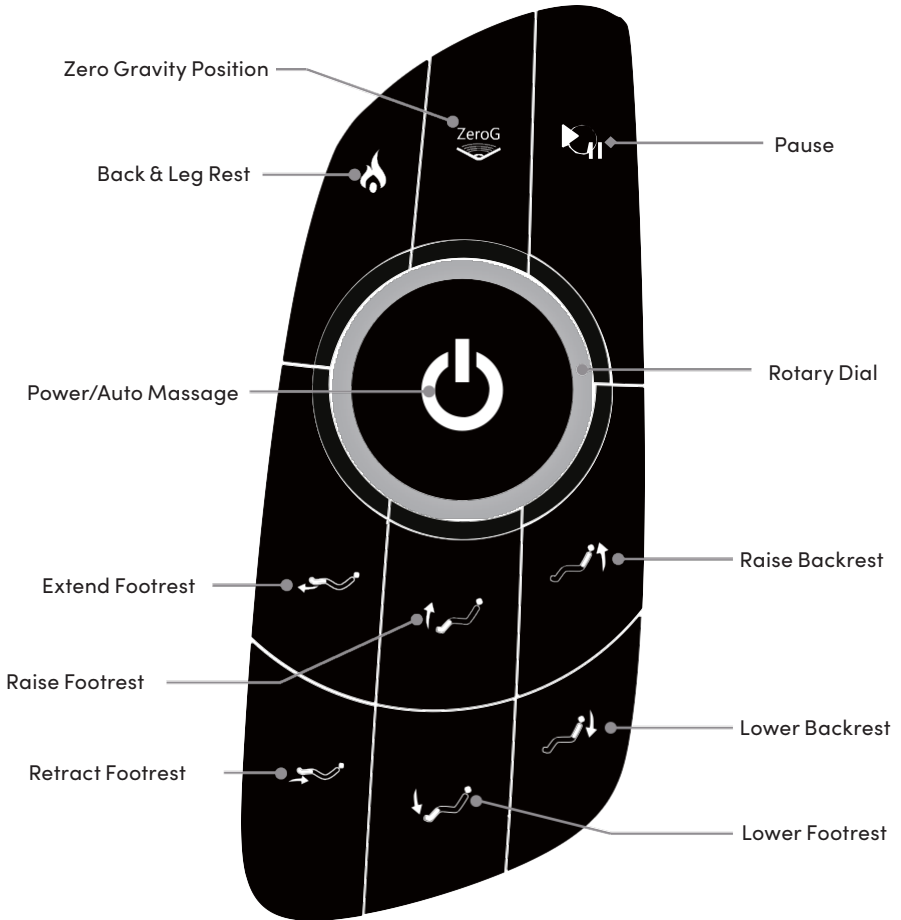

NAME AND INSTRUCTIONS FOR QUICK CONTROL BUTTONS



Power/Auto Massage

Long press to turn the chair on/off. Quick press rotary switch to toggle auto massage programs.



Rotary Switch

Rotate clockwise/counter-clockwise to increase/decrease 3-D massage intensity.



Zero Gravity Position

Press to position the chair in Zero Gravity Position. Press again to restore to the default position. A third press will restore to default position.



Footrest Extension

Press and hold to extend the Footrest. Release the button to stop. (Ensure there are no obstructions in the way of the footrest).



Footrest Retraction

Press and hold to retract the Footrest. Release the button to stop.



Pause

Press to pause the massage chair function. Press this button again to continue.



Raise Footrest

Press and hold to raise the Footrest. Release the button to stop.



Lower Footrest

Press and hold to lower the Footrest. Release the button to stop.



Back & Leg Heat

Press to turn on Back and Leg Heat function. Press again to turn this function off.



Raise Backrest

Incline: Press and hold to incline the backrest to upright position and release the button to stop.



Rotary Switch

Recline: Press and hold to recline the backrest. Release the button to stop. NOTE: - When the backrest reclines to its third quarter position, it will stop and wait for the lower mechanism to reach a safe clearance before it continues to recline.

Touch Screen Controller Instructions

The "Touch Screen Controller Instructions" can be found on the Touch screen Controller display.

FEATURES

1. One Press Control Sliding Forward

The chair will slide forward by 28cm and then recline.

The glider recliner linkage mechanism is for space saving purposes and to provide the ultimate positioning for relaxation.

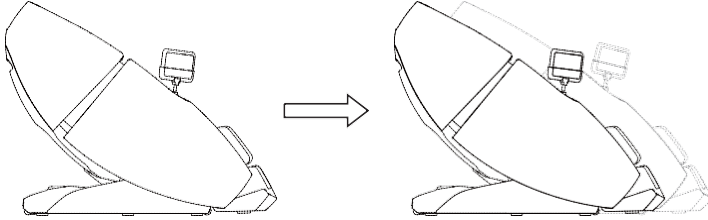

2. Zero Gravity Position

In this position, where the height of the legs are slightly higher than the upper body, the weight of the body can be evenly distributed throughout reducing the pressure on the spine and joints.

3. Auto/Manual Footrest Extension

The upper footrest can extend by 7cm and the lower footrest can extend by 15cm automatically for users of different heights.

4. Whole Body Air Compression Massage

Whole Body Air Compression Massage for shoulders, arms, back, waist, hips, legs and feet.

5. Roller Massage

Three rollers provide all-direction pressure massage for the reflexology zones.

6. Versatile Massage Techniques

These techniques mimic human hand kneading, knocking, synchronised tapping and shiatsu massage techniques with extra calf rubbing massage for bespoke relaxation.

INSTALLATION METHOD

We very much recommend visiting this excellent video giving full details of unpacking & installation



Step 1: Take all massage chair components and accessories out of the packaging

- Before beginning installation, please verify that all components are included (check against the Packing List carefully).

Step 2: Install Armrest Unit

- Connect the numbered air hoses to the matching numbered nozzles on both the armrests and plug in the air valve connector.

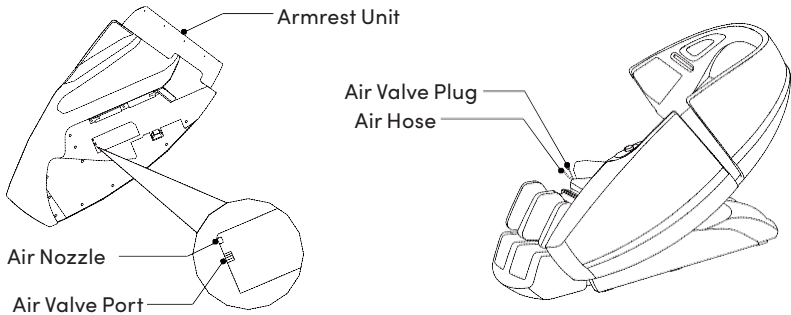

- Hold the armrest unit up and hook Hanger 2 onto the carrier groove. Slowly push the armrest unit back into the chair linkage until Hanger 2 aligns completely with Hanger 4. Insert Hanger 1 into Hanger 3 using a screw to secure the armrest into place. (Use the same procedure for the other side)

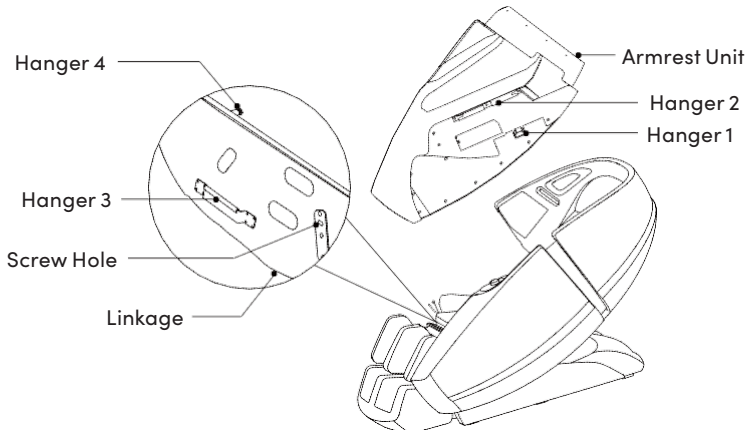

INSTALLATION METHOD

Step 3: Install Touch Screen Controller Holder

Insert the lower end of the Touch Screen Controller Holder into the socket and turn the nut clockwise to secure the holder into place.

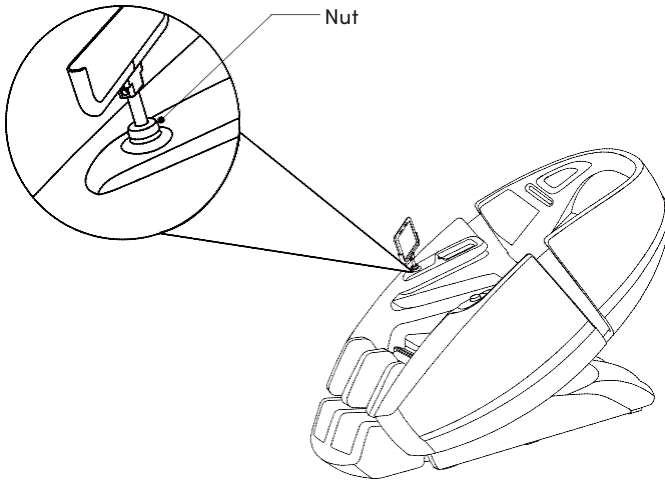

Step 4: Install the Footrest Unit

Raise the Leg rest unit & thread the Air Hose into the air nozzle, then fit the Air Valve Plug into the Air Valve Port which is located at the face side of the seat base making sure they are well secured.

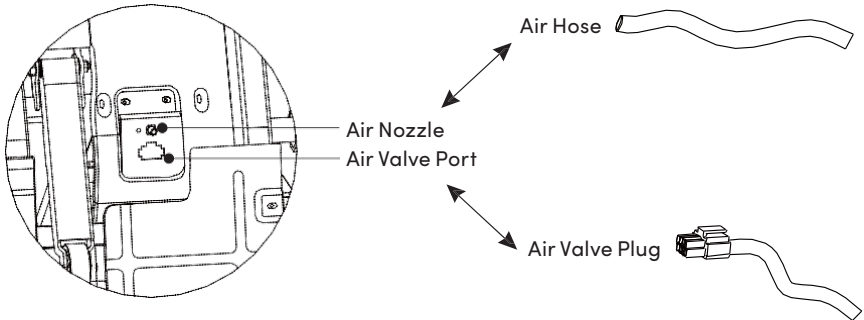

INSTALLATION METHOD

Put the Leg rest Hanger sleeve into the Leg rest Hanger. Attach the Leg rest Hanger onto the Leg rest Rotation Shaft. Then attach a DK Circlip to the end of the Leg rest Rotation Shaft to hold the leg rest in place, Zip the footrest and main chair together.

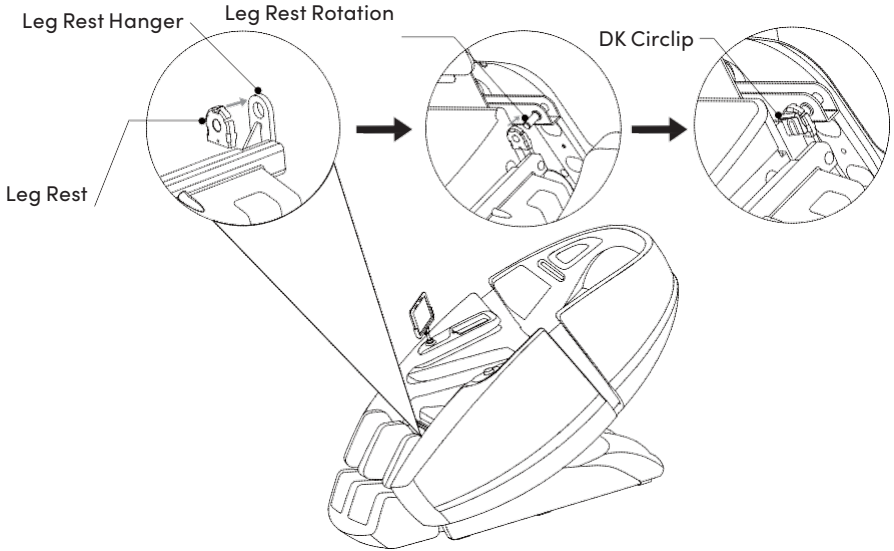

Step 5: Other Accessories

- Connect the power cable to the massage chair power socket (located at the power box on the chair).
- Switch ON the power switch located at the back of the power box. Raise the backrest of the chair to the fully upright position.

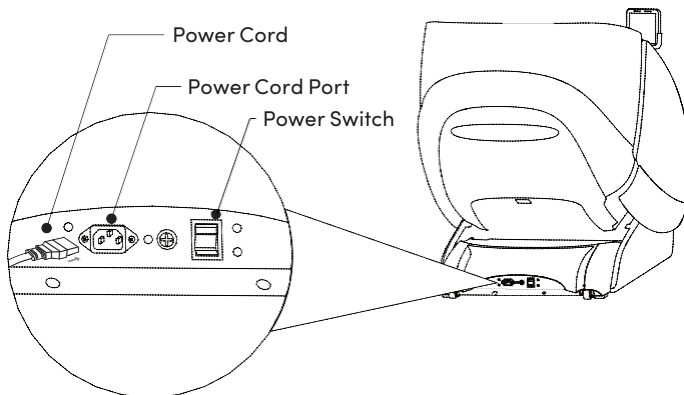

INSTALLATION METHOD

Installation Site

Clearance space for the massage chair:

- Ensure that there is at least a 10cm clearance from the wall to enable the recline of the backrest; a 60cm clearance space is needed for the extension of the footrest so that the mechanism can slide forward.
- Ensure that there is a 1m clearance from any TV, radio and/or other audio/video appliances to avoid electrical signal interference.

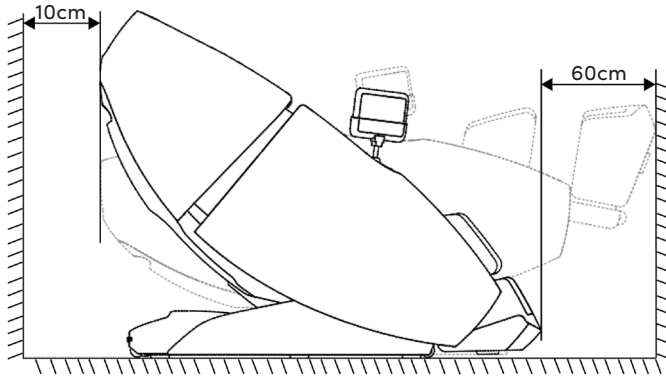

Floor Protection

We recommend placing a piece of carpet or a soft mat underneath the chair to avoid damaging any sensitive floor materials. (Please note that the chair works perfectly without any such soft matting)

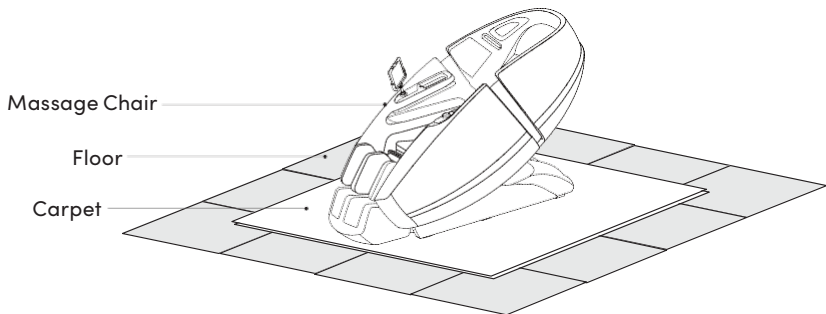

WARNINGS

WARNING



Do not use the massage chair in any high humidity environments, such as, but not limited to indoor swimming pools or bathrooms. This will prevent the possibility of an electric shock or other electric malfunctions in the chair.



Please keep the massage chair away from heated surfaces to prevent fire hazards or damage to the product.

DANGER



This chair must be fully earthed (grounded). The plug must be plugged into an appropriate 3-wire grounded outlet that is properly installed and in accordance with British Standards Regulations to reduce/avoid electrical danger.

ADVICE ON MOVING THE CHAIR

- Always ensure the backrest is in the upright position.
- Always roll the chair on its casters when moving to the desired location.
- Always turn off the power switch and unplug the appliance from the electrical outlet before moving.
- We suggest the chair be moved by two persons by pushing down on the backrest and lifting up on the front side by grabbing the moving holder located at the front bottom of the armrest. Roll the chair on its casters to the desired location (see sketch below or view an excellent video demonstrating how to move the RT8900).



CAUTION

- Do not move the chair whilst in use.
- Never lift the chair by the footrest.
- The chair needs a minimum of 4 persons to carry it when fully assembled

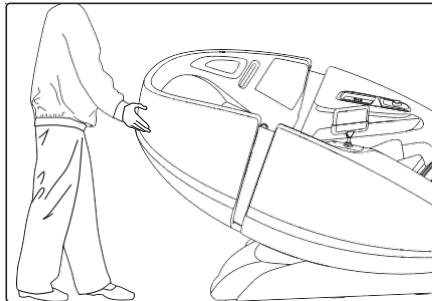

Connect to Power

- Connect this appliance to a 3-wire properly grounded outlet.
- Turn on the main power switch by the right-hand side of the massage chair.

CAUTION

- Ensure that there is no damage to the supply cord before switching on the massage chair.
- Ensure that the main power switch on the chair is turned "off" before connecting the chair to the power outlet.

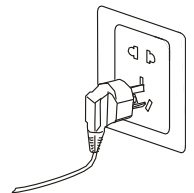

GETTING STARTED

- Use the quick access button to recline the backrest to its lowest position. Raise and extend the footrest to its top position, making sure there is enough clearance before commissioning.
- Return the backrest and footrest to its default position after use and not to forget to turn off the power switch. (To quickly choose a massage program, please use the Quick Access Buttons on the armrest of the chair).

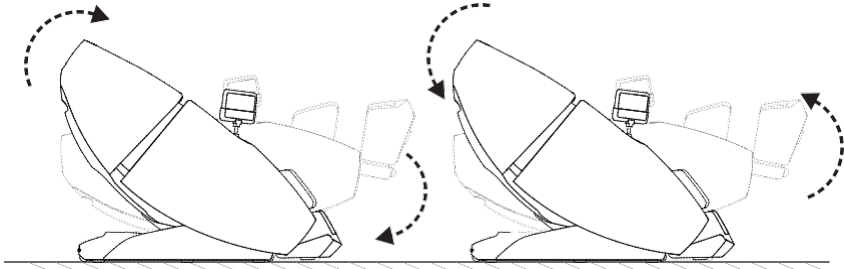



Before Sitting In The Chair

- Ensure the footrest is properly assembled.
- If there is any part of the chair that is not in the default raised position, then turn off the chair to allow it to restore.

CAUTION

- Do not attempt to sit on the chair whilst the footrest is raised,
 - Do not put any excessive load on the footrest to avoid damage.
-

LEG EXTENSION/RETRACTION

Press and hold “” or “” button to extend or retract the footrest to the length you

Footrest Extended 

Footrest Retracted 

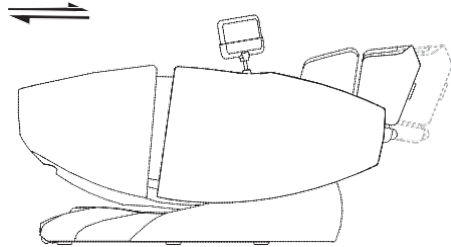

A footrest sensor is set at the bottom of the footrest. The footrest will adjust the length

WARNING

- Do not play on the massage chair or operate it improperly.
- Ensure there is no obstruction when raising or reclining the backrest and footrest.
- Do not place feet, fingers, or any other objects in the space between the seat and the backrest/footrest when it is either reclining or raising.
- Ensure the massage chair has fully stopped in the original default/upright position before getting off.

After Using the Chair

- Always unplug the massage chair from the electrical outlet immediately after use.
- Secure the centre console onto the holder.
- Turn off the power switch and unplug the massage chair from the electrical outlet while not in use to avoid children switching it back on accidentally.
- When not in use for a long period of time, we recommend that the chair be covered, the power cord be coiled and that the unit be placed in an environment free of dust and moisture.

CARE AND MAINTENANCE INSTRUCTIONS

- To treat stains on back panel, armrest, footrest, plastic parts or air hose, spot clean with a mild detergent foam then wipe it with a dry clean cloth.
 - To treat stains on the controller or power box, spot clean with a dry clean cloth.
 - To treat stains on back cushion or pillows, use a water-based upholstery cleaner only. Wipe it with a moist cloth and leave to dry.
 - To clean the foot/calf unit covers, remove it from the chair and hand wash with a mild detergent, then line dry.
-

CAUTION

- Pull out the power cord from the power box before care and maintenance. To avoid electrical shock or injury, do not touch the power cord with wet hands. Make sure no detergent enters into the power box whilst cleaning.
 - Do not use benzene thinner or other solvents on your product. It may cause fading or damage the product.
 - Do not iron the upholstery.
-

Storage Methods

- Keep the product free from dust. Cover the product with a dust-free cloth to prevent collection of dust if not in use for a long period of time.
-

CAUTION

- Do not leave this product exposed to direct sunlight for long periods of time. This may cause fading or damage.
-

Electrical Safety Advice

During daily use, please check for the following symptoms:

- Burning smells.
 - The power switches ON/OFF while you are touching the power cord.
 - The power cord overheating.
 - Other abnormal symptoms.
-

CAUTION

- Please stop using the product to avoid breakdowns or accidents if any electrical symptoms are noticed.
 - Switch off the power button and disconnect the plug and contact your local dealer or supplier for repair.
 - All other servicing, care and maintenance, other than the above advice, should only be serviced by an authorised dealer or service centre.
-

WARNING

- To avoid electrical shock or injury, do not handle the power cord with wet hands. Do not try to dismantle or repair the product yourself, Please contact your authorised service centre.
- Please note that if any repairs are carried out by anyone other than an authorised dealer or service centre, all warranties will be void

Trouble Shooting

No	Symptoms	Possible Causes	Possible Solutions
1	Tapping or humming sound is heard	This sound is normal and comes from the air pump motor or other mechanical parts rubbing against the cloth cover	No need to take any measures
2	Massage Chair does not start	The power cord is not secured into the socket	Insert the power plug properly into the power socket
		Power switch is off	Turn on the switch
		The fuse is blown	Replace only with a fuse of same type and rating
3	No music comes from the speaker	The volume is set to the lowest or muted	Adjust the speaker volume from the mobile devices
		Bluetooth is off	Switch on Bluetooth
		Bluetooth didn't connect with music device Bluetooth connected with other device	Reconnect Bluetooth
4	Backrest or footrest cannot raise or recline	Excessive load has been pressed on the backrest or leg-rest	Reduce the load and try again

If problems persist, please contact your dealer for further troubleshooting.

Important: Do not attempt to repair this product yourself. The dealer/importer shall not be liable for any injury or damage caused by any servicing carried out without their authorisation. Please note that any unauthorised repairs will void any warranty.

Product Specification

Name: Rotai Ultimate (Dual-Core) Massage Chair (UK Specification)

Model: RT8900

Rated Voltage: 220-240V~

Rated Frequency: 50/60Hz

Rated Power: 180W

Safety Design: Class 1