

OM

COMPACT SUBMERSIBLE SEMI-VORTEX PUMP FOR DEWATERING OPERATION MANUAL

INTRODUCTION

Thank you for selecting a Tsurumi Compact Submersible Semi-Vortex pump for your dewatering application. This equipment should not be used for applications other than those listed in this manual. Failure to observe this precaution may lead to a malfunction or an accident. In the event of a malfunction or an accident, the manufacturer will not assume any liability. After reading this Operation Manual, keep it in a location that is easily accessible, so that you can refer to it whenever you need information while operating this product.

CONTENTS

1. BE SURE TO READ FOR SAFTY	1
2. PART NAMES	4
3. PRIOR TO OPERATION	4
4. INSTALLATION	5
5. ELECTRICAL WIRING	7
6. OPERATION.....	8
7. MAINTENANCE AND INSPECTION	10
8. DISASSEMBLY AND REASSEMBLY PROCEDURE	12
9. TROUBLESHOOTING	14

1 BE SURE TO READ FOR YOUR SAFETY

Be sure to thoroughly read and understand the SAFETY PRECAUTIONS given in this section before using the equipment in order to operate the equipment correctly.



The precautionary measures described in this section are intended to prevent danger or damage to you or to others. The contents of this manual that could possibly be performed improperly are classified into two categories: **⚠ WARNING**, and **⚠ CAUTION**. The categories indicate the extent of possible damage or the urgency of the precaution. Note however, that what is included under **⚠ CAUTION** may at times lead to a more serious problem. In either case, the categories pertain to safety-related items, and as such, must be observed carefully.

- **⚠ WARNING** : Operating the equipment improperly by failing to observe this precaution may possibly lead to death or injury to humans.
- **⚠ CAUTION** : Operating the equipment improperly by failing to observe this precaution may possibly cause injury to humans and other physical damage.
- **NOTE** : Gives information that does not fall in the WARNING or CAUTION categories.

● Explanation of Symbols:

















- ⚡ : The ⚠ mark indicates a WARNING or CAUTION item. The symbol inside the mark describes the precaution in more detail ("electrical shock", in the case of the example on the left).
- ⊘ : The ⊘ mark indicates a prohibited action. The symbol inside the mark, or a notation in the vicinity of the mark describes the precaution in more detail ("disassembly prohibited", in the case of the example on the left).
- ⏚ : The ● mark indicates an action that must be taken, or instructs how to perform a task. The symbol inside the mark describes the precaution in more detail ("provide ground work", in the case of the example on the left).

PRECAUTIONS TO THE PRODUCT SPECIFICATIONS

















⚠ CAUTION	
	<ul style="list-style-type: none"> ● Do not operate the product under any conditions other than those for which it is specified. Failure to observe the precaution can lead to electrical leakage, electrical shock, fire, or water leakage, etc.
	



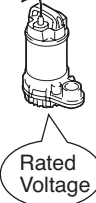

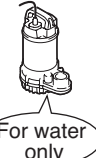

PRECAUTIONS DURING TRANSPORT AND INSTALLTION

⚠ WARNING	
<ul style="list-style-type: none"> ● When transporting the product, pay close attention to its center of gravity and mass. Use an appropriate lifting equipment to lift the unit. Improper lifting may result in the product damage, injury, or death. 	<ul style="list-style-type: none"> ● Install the product properly in accordance with this instruction manual. Improper installation may result in electrical leakage, electrical shock, fire, water leakage, or injury.
<ul style="list-style-type: none"> ● Electrical wiring should be performed in accordance with all applicable regulations in your country. Provide a dedicated earth leakage circuit breaker and a thermal overload relay for the pump. Imperfect wiring or neglecting the installation of proper equipment will cause electrical leakage, fire, or explosion at worst. 	<ul style="list-style-type: none"> ● Provide a secure grounding dedicated for the product. Never fail to provide an earth leakage circuit breaker and a thermal overload relay in your starter or control panel (Both available on the market). If an electrical leakage occurs by due to a product failure, it may cause electrical shock.
<ul style="list-style-type: none"> ● Use a power outlet that has a sufficient rating and has been exclusively provided for the pump. If the power outlet is shared with other equipment, it can lead to an abnormal heat of the outlet and can cause fire as a result. 	<div style="text-align: right;">  </div>





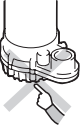

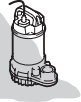

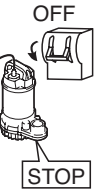

 CAUTION			
	<ul style="list-style-type: none"> ● Be sure to provide a ground wire securely. Do not connect the ground wire to a gas pipe, water pipe, lightning rod, or telephone ground wire. Improper grounding could cause electrical shock. 		<ul style="list-style-type: none"> ● Prevent a metallic object or dust from sticking to the power plug. Adhesion of foreign object to the plug could cause electrical shock, short-circuit, or fire. 
	<ul style="list-style-type: none"> ● Do not scratch, fold, twist, make alterations, or bundle the cable, or use it as a lifting device. The cable may be damaged, which may cause electrical leakage, short-circuit, electrical shock, or fire. 		<ul style="list-style-type: none"> ● Do not use the cable, power plug, or power outlet if it is damaged or it is not closely fitted. Connect every conductor of the cable securely to the terminals. Failure to observe this can lead to electrical shock, short-circuit, or fire. 
	<ul style="list-style-type: none"> ● Install the discharge pipe securely so that no water leakage may occur. In addition, It is suggested to provide a stand-by pump in case of flooding. Failure to do so may result in damage to nearby walls, floors, and other equipment. 		<ul style="list-style-type: none"> ● When the product will be carried by hand, decide the number of persons considering the mass of the product. When lifting up the product, do not attempt to do it by simply bowing from the waist. Use the knees, too, to protect your waist. 
	<ul style="list-style-type: none"> ● This pump is neither dust-proof nor explosion-proof. Do not use it at a dusty place or at a place where toxic, corrosive or explosive gas is present. Use in such places could cause fire or explosion. 		<ul style="list-style-type: none"> ● If a hose is used for the discharge line, take a measure to prevent the hose from shaking. If the hose shakes, you may be wet or injured. 

PRECAUTIONS DURING TEST OPERATION AND OPERATION



 WARNING			
	<ul style="list-style-type: none"> ● Never try to operate the pump if somebody is present in the pump sump. If an electrical leakage occurs, it can cause electrical shock. 		<ul style="list-style-type: none"> ● Never start the pump while it is suspended, as the unit may jerk and could lead to injury. 
	<ul style="list-style-type: none"> ● When changing power connection is needed to correct the direction of rotation, be sure to turn off the power supply (earth leakage circuit breaker, etc.), and perform the work after making sure that the impeller has stopped completely. Failure to do so may lead to electrical shock, short-circuit, or injury. 		<ul style="list-style-type: none"> ● When inspecting the pump, be sure to turn off the power supply (earth leakage circuit breaker, etc.) so that the pump may not start accidentally. Failure to do so may lead to a serious accident. 
 CAUTION			
	<ul style="list-style-type: none"> ● Do not operate the product under any voltage other than described on the nameplate with the voltage variation limit within $\pm 10\%$. If it is operated with a generator, it is strongly suggested not to operate other equipment with the same generator. Failure to observe this caution may cause malfunction and breakdown of the product, which may lead to electrical leakage or electrical shock. 		<ul style="list-style-type: none"> ● Do not touch the product with bare hands during or immediate after the operation, as the product may become very hot during operation. Failure to observe this caution may lead to be burned. 
	<ul style="list-style-type: none"> ● Do not use the product in a liquid other than water. Use in oil, salt water or organic solvents will damage it, which may lead to electrical leakage or electrical shock. 		<ul style="list-style-type: none"> ● Do not run the product dry or operate it with its valve (sluice or gate valve) closed, as doing so will damage the product, which may lead to electrical leakage or electrical shock. 

 CAUTION	
	<p>● Do not use the product for hot or warm liquid over 40°C, as doing so will damage the product, which may lead to electrical leakage or electrical shock.</p> 
	<p>● Do not allow foreign objects (metal objects such as pins or wires) to enter the suction inlet of the pump. Failure to observe this caution could cause it to malfunction or to operate abnormally, which may lead to electrical leakage or electrical shock.</p> 
	
<p>● When the product will not be used for an extended period, be sure to turn off the power supply (earth leakage circuit breaker, etc.). Deterioration of the insulation may lead to electrical leakage, electrical shock, or fire.</p>  	



PRECAUTIONS DURING MAINTENANCE AND INSPECTION

 WARNING	
	<p>● Absolutely turn off the power supply or disconnect the plug before starting maintenance or inspection. Do not work with wet hands. Failure to observe these cautions may lead to electrical shock or injury.</p> 
	<p>● In case any abnormality (excessive vibration, unusual noise or odor) is found in the operation, turn the power off immediately and consult with the dealer where it was purchased or Tsurumi representative. Continuing to operate the product under abnormal conditions may result in electrical shock, fire, or water leakage.</p> 
	
<p>● Do not disassemble or repair any parts other than those designated in the operation manual. If repairs are necessary in any other than the designated parts, consult with the dealer where it was purchased or Tsurumi representative. Improper repairs can result in electrical leakage, electrical shock, fire, or water leakage.</p> 	
 CAUTION	
	<p>● After reassembly, always perform a test operation before resuming use of the product. Improper assembly can result in electrical leakage, electrical shock, fire, or water leakage.</p> 

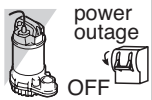
PRECAUTION TO POWER OUTAGE

 WARNING	
	<p>● In case of power outage, turn off the power supply. The product will resume operation when the power is restored, which presents serious danger to people in the vicinity.</p> 

OTHER PRECAUTION

 CAUTION	
	<p>● Never use the product for potable water. It may present a danger to human health.</p> 

2 PART NAMES

Example

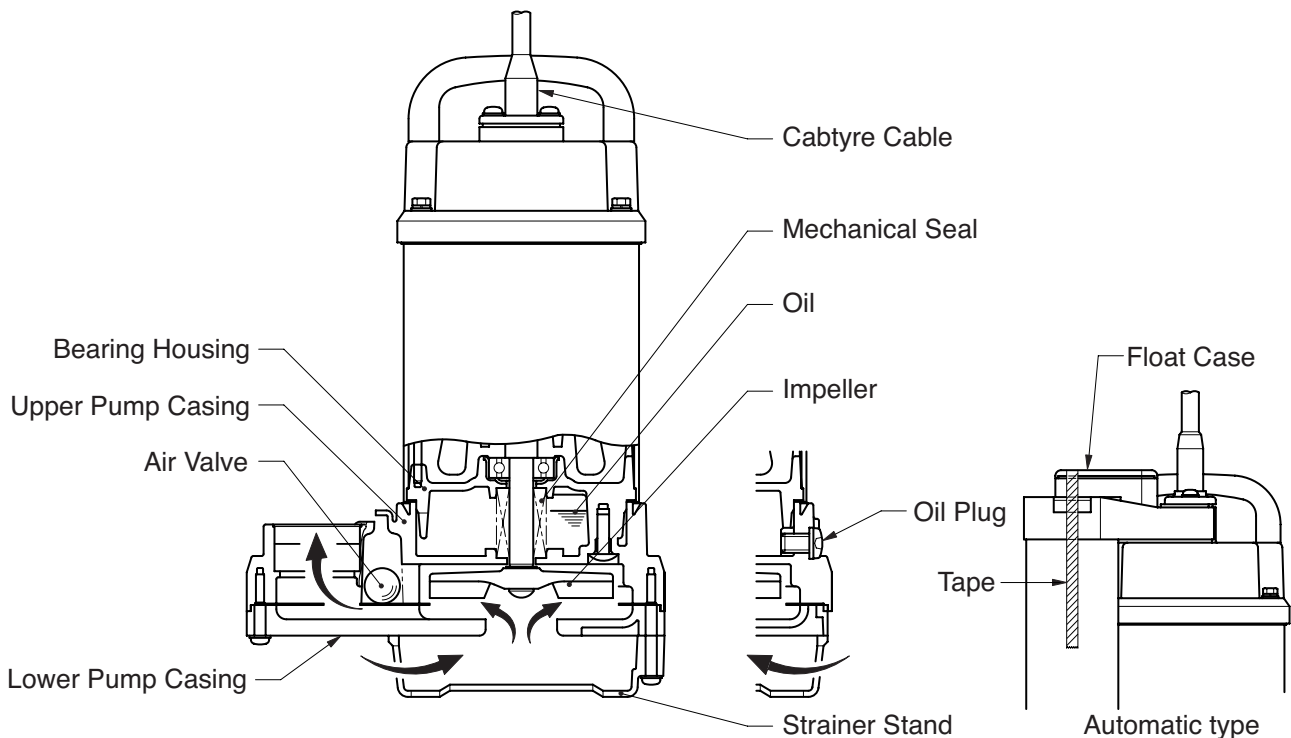

3 PRIOR TO OPERATION

Check the following points after unpacking the package:

Inspecting the Product

Verify that no damage has occurred to the pump during shipment and that the bolts and nuts have not loosened.

A certain automatic pump has a piece of tape affixed to the float case, in order to prevent it from becoming detached during transport. Please remove the tape before using the pump.

Inspecting the Specifications

Check the nameplate of the pump unit to verify that it is the product that you have ordered. Pay particular attention to its voltage and frequency specifications.

Inspecting the Accessories

Verify that the following accessories are included in the package:

Operation Manual..... 1

Note: *If you discover any damage or discrepancy, please contact the dealer where this equipment was purchased, or the Tsurumi sales office in your area.*

Product Specifications

CAUTION Never use the product under conditions other than those that are specified in the product specifications.

Main Component Specifications

Applicable Liquids	Type and Temperature	Storm water and waste water, ; 0 ~ 40°C
Pump	Impeller	Semi-Vortex
	Shaft Seal	Double mechanical seal
	Bearing	Sealed ball bearing
Motor	Specifications	Dry type submersible induction motor: single-phase 150W, 2 poles
	Insulation	Class E
	Protection System (built-in)	Miniature protector
	Oil	Liquid Paraffin VG 32
Connection		32mm screwed flange

4 INSTALLATION

CAUTION

- Do not use the pump for pumping liquids other than plain water, such as oil, salt water, or organic solvents.
- Use with a power supply voltage variation within $\pm 10\%$ of the rated voltage.
- Use the pump at the water temperature of between 0 and 40°C.
- Failure to observe these precautions could cause the pump to malfunction, which may lead to current leakage or electrical shock.

Note: To use the pump for a special solution, contact the dealer where the pump was purchased, or the Tsurumi sales office in your area.

Critical Use Pressure

CAUTION Do not operate the pump in an area that is exposed to a water pressure that exceeds the values given below.

Critical Use Pressure	0.2MPa (2kgf/cm ²) - discharge pressure during use
-----------------------	--

Pre-Installation Check

Using a megger, measure the resistance between the tip of the cabtyre cable plug and the ground pole (using alligator clips) to verify the insulation resistance of the motor.

*The power plug could vary by country or region.

Insulation resistance reference value = 20M Ω minimum

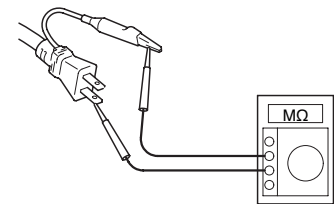

Note: The insulation resistance reference value of 20 M Ω minimum is based on a new or repaired pump. For reference values of a pump that has already been put into operation, refer to "7. Maintenance and Inspection" in this manual.

Precautions During Installation

WARNING When installing the pump, be mindful of the pump's center of gravity and weight. If the pump is not suspended properly, the pump may fall and break, which may lead to injury.

CAUTION When installing or moving the pump, do not suspend the pump by the cabtyre cable. Doing so will damage the cable, which may cause a current leakage, electrical shock, or fire.

Refer to the installation examples illustrated below and pay attention to the points described below to install the pump.

CAUTION If the welding sparks, paint, or concrete come in contact with the pump during piping work, they could cause the pump to malfunction, which may lead to current leakage or electrical shock.

- Prepare the Piping
Screw the supplied hose coupling or a valve socket (32mm, commercially available) into the discharge outlet. Push the hose fully over the hose coupling, and secure it in place with the hose clamp.
When using a valve socket, cut a PVC pipe (32mm, commercially available) to an appropriate length, and push it over the valve socket.
Prepare the piping by obtaining commercially available products such as valves, elbows, and check valves as necessary.
* Install a check valve (commercially available) immediately after the discharge outlet of the pump if there is the likelihood of the water in the pipe flowing backward when the pump is stopped, thus causing the pump to turn ON and OFF repeatedly.

CAUTION When screwing a metal pipe directly into the discharge outlet, make sure not to overtighten it, as doing so could cause the discharge outlet to break.

- Install the pump in water and connect the pipes. Hold the pump by the handle to install it on a level surface in the water. To change the water level for automatic operation, adjust the height of the pump by placing the pump body on a concrete block or the like. Use elbows to connect the PVC pipes.

- * To connect the pipes, use a dedicated adhesive that is commercially available, as needed.
Extend the discharge end of the pipe to a location that is higher than the water level.
- * If the end of the pipe is in the water, the water in the pipe could flow backward when the pump is stopped.
If the end of the pipe is located lower than the water level, the water could flow out even after the pump is stopped.

- During transport or installation, do not kink the cabtyre cable or use it in place of a rope.
- With the cabtyre cable lifted slightly, secure it to the hook (a hook must be prepared in advance by placing it on the frame of a manhole or the like).

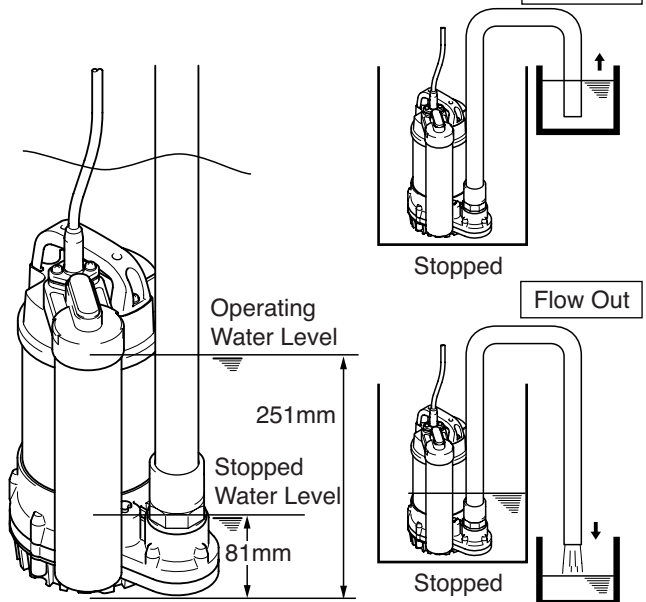
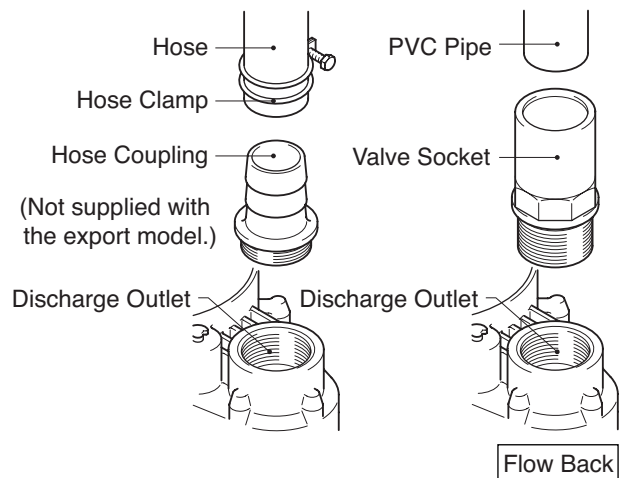
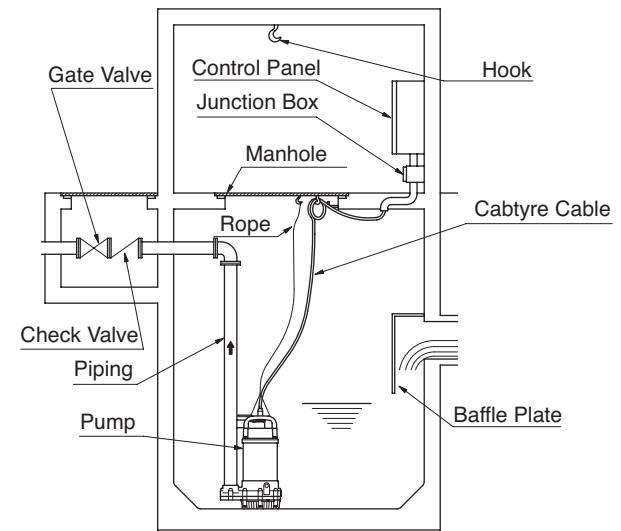

⚠ CAUTION Do not operate the pump with the cable dangling. Failure to observe this precaution may cause the cable to become wrapped around the impeller, which could cut the cable, break the impeller, or cause flooding, which may lead to current leakage or electrical shock.

- (5) Install the submersible pump upright on top of a surface such as concrete, in an area that is free of turbulence and does not cause the pump to take air in.
- (6) The area near the inlet of a water tank is susceptible to turbulence or allows the pump to take air in; therefore, place the pump and the float switch away from the inlet or install a baffle plate.
- (7) Carry out piping work properly so as not to create any air pockets in the middle of piping.

⚠ CAUTION With automatic control, the water in the pipe could flow backwards, causing the water surface control device to react immediately. As a result, the pump will operate ON/OFF repeatedly, which could cause the pump to malfunction.

- (8) Install a check valve if the pump tank is deep, or the vertical head or the lateral distance is long.

▶ Attaching a Rope to Suspend the Pump

Refer to the illustration on the right in order to suspend the pump by a rope.

⚠ CAUTION Make sure that the rope does not become twisted during installation. Failure to observe this precaution could cause the rope to break, the pump to fall and break, which could lead to injury.

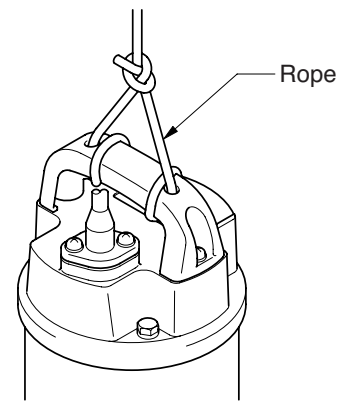

5 ELECTRICAL WIRING

▶ Electrical Wiring Work

- ⚠ WARNING**
- All electrical work must be performed by an authorized electrician, in compliance with the local electrical equipment standards and internal wiring codes. Never allow an unauthorized person to perform electrical work because it is not only against the law, but it can also be extremely dangerous.
 - Improper wiring can lead to current leakage, electrical shock, or fire.
 - Absolutely provide a dedicated earth leakage circuit breaker and a thermal overload relay suitable for the pump (available on the market). Failure to follow this warning can cause electrical shock or explosion when the product fails or an electrical leakage occurs.

Make sure that the power supply and wiring have adequate capacity.

▶ Grounding

⚠ WARNING Make sure to install the ground wire securely. Failure to observe this precaution could damage the pump and cause current leakage, which may lead to electrical shock.

⚠ CAUTION Do not connect the ground wire to a gas pipe, water pipe, lightning rod, or telephone ground wire. Improper grounding could cause electrical shock.

Connecting the Power Supply



WARNING

Before connecting the power plug or connecting the cable to the terminal board, make sure that the power supply (i.e. circuit breaker) is properly disconnected. Failure to do so may lead to electrical shock, short, or injury caused by the unintended starting of the pump.



CAUTION

Do not use the pump if the cable is damaged or the power plug is loosely connected. Failure to observe this precaution may cause electrical shock, short, or fire.

Connect the power supply as illustrated on the right.

Be sure to use a dedicated circuit breaker (such as a plug-in type circuit breaker) of a prescribed rating for the pump, which is commercially available.

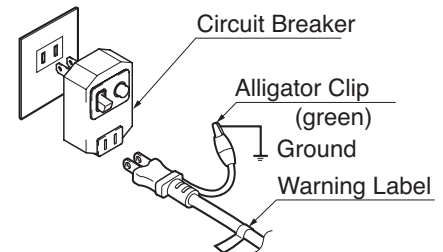

Motor Protector

The pump is equipped with an internal miniature protector for the motor.

Miniature Protector

To protect the motor, if a current overload occurs in the motor or if the motor overheats under the conditions given below, the pump will stop automatically, regardless of the water level during operation.

- Extreme fluctuation of power supply voltage
- Pump operated under overload condition
- Pump operated at binding condition

Note: *The motor protector will cancel automatically after it has been tripped. Therefore, make sure to disconnect the cable from the power outlet and eliminate the cause of the problem. Do not operate the pump at an extremely low water level or with its impeller clogged with debris. Doing so will prevent the pump from attaining its full potential and may also generate abnormal noise and vibration and cause damage to the pump.*

6 OPERATION

Prior to Operation

- (1) Once again, check the nameplate of the product to verify that its voltage and frequency are correct.



CAUTION

Improper voltage and frequency of the power supply will prevent the pump from attaining its full potential, and may also damage the product.

Note: *Verify the specs on the pump's nameplate.*

- (2) Check the wiring, power supply voltage, the capacity of the ground leakage circuit breaker, and the insulation resistance of the motor.

■ Insulation resistance reference value = 20MΩ minimum

Note: *The insulation resistance reference value of 20 MΩ min. is based on a new or repaired pump. For reference values of a pump that has already been put into operation, refer to "Maintenance and Inspection" in this manual.*

- (3) Adjust the setting of the thermal relay to the pump's rated current.

Note: *Verify the rated current on the pump's nameplate.*

▶ Trial Operation

⚠ WARNING Never start the pump while it is suspended, as the pump may jerk and cause a serious accident involving injury.

(1) Operate the pump for a short time (3-10 minutes) and verify its operating conditions.

⚠ CAUTION If the pump generates a considerable amount of vibration, noise, or smell, disconnect the power supply immediately and contact the dealer where the pump purchased, or the Tsurumi sales office in your area. If the pump is continued to be used in the abnormal state, it may cause current leakage, electrical shock, or fire.

(2) Continue operation if no abnormal conditions are found during the trial operation.

▶ Operation

⚠ WARNING The pump may be extremely hot during operation. To prevent burns, do not touch the pump with bare hands during and immediately after an operation.

Pay attention to the water level during the pump operation. The pump will become damaged if it is allowed to operate dry.

If the motor protector trips to stop the pump due to an overload operation or a pump malfunction, make sure to eliminate the cause of the problem before restarting.

To operate the submersible pump automatically, set the water level so that the pump will operate about 10 times per hour.

Note: *A large starting amperage flows through the submersible motor, which causes the temperature in the windings to rise suddenly. Continuing to operate the pump in this manner will accelerate the deterioration of the insulation of the motor windings, which will affect the life of the motor. For this reason, minimize the frequency of starting and stopping the pump.*

▶ Operating Water Level

⚠ CAUTION Do not operate the pump below the continuous running water level longer than 30 minutes, as it could damage the pump, causing current leakage and electrical shock.

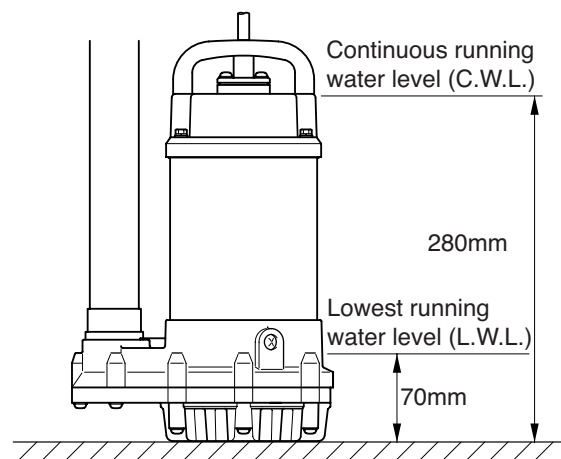

7 MAINTENANCE AND INSPECTION

Regular maintenance and inspection are indispensable in maintaining the pump's performance. If the pump behaves differently from its normal operating condition, refer to the section "9. Troubleshooting" of this manual and take appropriate measures at an early stage. We also recommend that you have a spare pump on hand for an emergency.

Prior to Inspection

WARNING Make sure that the power supply (i.e. circuit breaker) is disconnected, and remove the cable from the power outlet. Failure to do so may cause electrical shock or unintended starting of the pump, which may lead to serious accidents.

- (1) Washing the Pump
Remove any debris attached to the pump's outer surface, and wash the pump with tap water. Pay particular attention to the impeller area, and completely remove any debris from the impeller.
- (2) Inspecting the Pump Exterior
Verify that there are no damaged areas, and that the bolts and nuts have not loosened.

Note: If the pump must be disassembled for repair due to damage or loose bolts or nuts, contact the dealer where it was purchased, or the Tsurumi sales office in your area.

Daily and Periodic Inspection

Interval	Inspection Item
Daily	Measuring the operating current ■ To be within the rated current Measuring the power supply voltage ■ Power supply voltage variation = within $\pm 10\%$ of the rated voltage
Monthly	Measuring the insulation resistance ■ Insulation resistance reference value = 1M Ω minimum [NOTE] The motor must be inspected if the insulation resistance is considerably lower than that obtained during the last inspection.
Semi-yearly	Inspecting oil ■ Inspect every 1,500 hours or 6 months, whichever comes first. Inspection of lifting rope ■ Replace if damage, corrosion, or wear has occurred to the rope. Remove if foreign object is attaching to it.
Yearly	Changing oil ■ Change every 3,000 hours or 12 months, whichever comes first. Replacing the mechanical seal [NOTE] The inspection and replacement of the mechanical seal requires specialized skills. Therefore, to have this operation performed, contact the dealer where this equipment was purchased, or the Tsurumi sales office in your area.
Once every 2 to 5 years	Overhaul ■ The pump must be overhauled even if it appears normal during operation. Especially, the pump may need to be overhauled earlier if it is used continuously. [NOTE] To overhaul the pump, contact the dealer where it was purchased, or the Tsurumi sales office in your area.

Note: Refer to Oil Inspection and Change Procedures indicated below, for details on inspecting and changing oil.

Storage During Non-Operation

If the pump will not be operated for a long period of time, pull the pump up, wash it, allow it to dry, and store it indoors.

Note: For reinstallation, be sure to perform a trial operation before putting the pump into operation.

If the pump remains immersed in water, operate it on a regular basis (i.e. once a week) to prevent the impeller from seizing due to jammed debris.

Oil Inspection and Change Procedures

Oil Inspection

Remove the oil plug and take out a small amount of oil. The oil can be extracted easily by tilting the pump so that the oil plug faces downward.

If the oil appears milky or intermixed with water, a likely cause is a defective shaft sealing device (i.e. mechanical seal), which requires that the pump be disassembled and repaired.

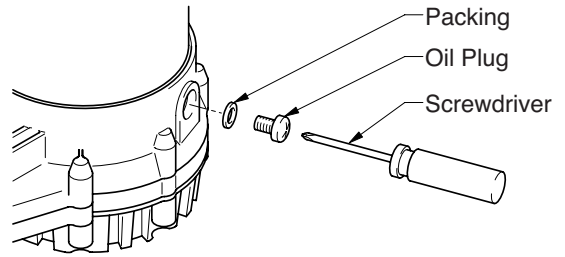

Changing Oil

Remove the oil plug and drain the oil completely. Pour a specified volume of oil into the oil inlet.

Specified Oil: Liquid Paraffin VG32 Unit : ml

Applicable Model	Specified Volume
Model with 0.15kW output	165

Note: *The drained oil must be disposed of by waste disposal contractors in compliance with the laws of the respective country in which the pump is being used.
The packing and the O-ring for the oil plug must be replaced with a new part at each oil inspection and oil change.*

8

DISASSEMBLY AND REASSEMBLY PROCEDURE

■ Prior to Disassembly and Reassembly



WARNING

Before disassembling and reassembling the pump, be sure that the power supply (i.e. circuit breaker) is disconnected, and remove the cable from the outlet. Do not perform this operation with a wet hand, which could cause electrical shock. To prevent serious accidents, do not perform an activation test (to check the rotation of the impeller) during disassembly and reassembly.

This section explains the disassembly and reassembly processes that are involved up to the replacement of the impeller itself. Operations involving the disassembly and reassembly of the sealing portion (i.e. mechanical seal) and of the motor require a specialized facility including vacuum and electrical test equipment. For these operations, contact the dealer where this equipment was purchased, or the Tsurumi sales office in your area.

Disassembly Procedure

■ Suction Inlet

- (1) Place the pump sideways, and thoroughly wash the inside of the pump through the suction inlet.

■ Inside the Pump

- (1) If the inside of the pump is clogged with debris, remove the bottom pump casing and the nine screws at the bottom of the strainer by using a Philips screwdriver.
- (2) Remove the bottom pump casing and the packing together, and use your hands to remove the debris from the impeller.
- (3) After removing the debris, check that the impeller spins smoothly by turning it with your hand.
- (4) If the impeller does not spin smoothly, remove the cross recessed head truss screw with flat washer, and remove the spring washer with the impeller, in order to remove the debris from behind the impeller.

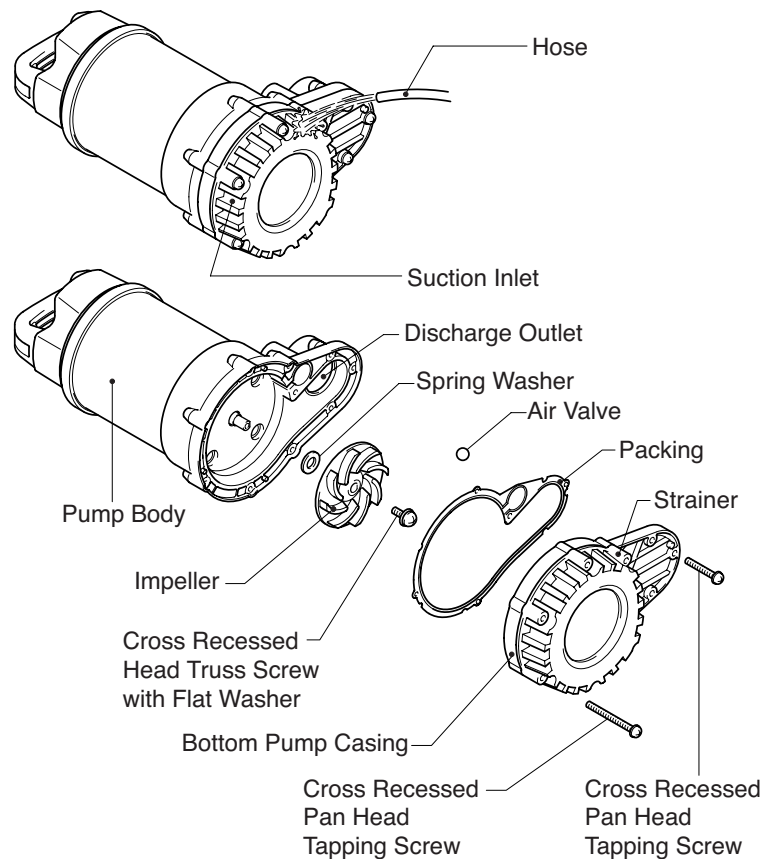

WARNING

Never disassemble areas other than those that are indicated above. Improper disassembly may cause the pump to malfunction and lead to current leakage, electrical shock, or fire.

Reassembly Procedure

- (1) Turn the pump body upside down, insert the air valve, and install the packing on the pump body. While installing the packing, align its position properly with the pump body.
- (2) Then, place the bottom pump casing and the strainer, and tighten the nine screws with a Philips screwdriver.

How to Clean the Float Case (automatic type only)

If the pump is running in spite of the water having descended to the stopping level, or the pump does not start in spite of the water having reached the starting level, the inside of the float case must be cleaned. To prevent the pump from operating improperly, clean the float case according to the following procedure.

- (1) Lightly grasp the top of the float case and hold the protrusion at the bottom of the float case.

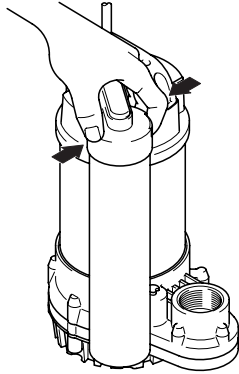

- (2) Turn the bottom of the float case clockwise, as viewed from the top of the pump.

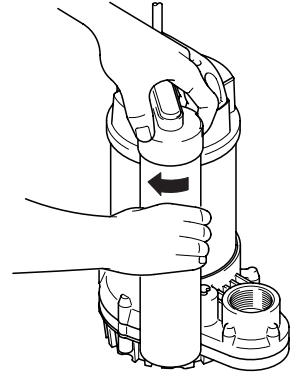

- (3) Pull the bottom of the float case directly downward.

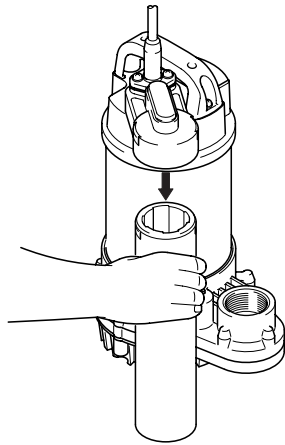

- (4) Wash the inside of the case with water. Then, use your fingers to lightly press the protrusion at the bottom of the float case as shown in arrow "a", and press it in the direction of arrow "b".

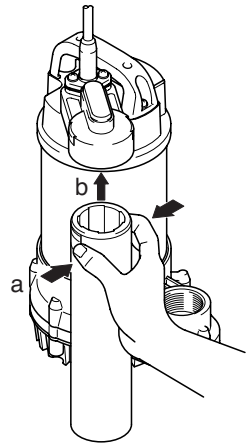

CAUTION

Never disassemble areas other than those that are indicated above. Improper disassembly may lead to a malfunction.

9 TROUBLESHOOTING

⚠ WARNING To prevent serious accidents, disconnect the power supply before inspecting the pump. Failure to observe this precaution may lead to a serious accident.

Read this Operation Manual carefully before requesting repair. After re-inspecting the pump, if it does not operate normally, contact the dealer where this equipment was purchased, or the Tsurumi sales office in your area.

Problem	Possible cause	Countermeasure
Pump fails to start, or starts but stops immediately	(1)No power is supplied (i.e. power outage). (2)Automatic controller (control panel) malfunction (3)Protector has tripped due to jammed debris.	(1>Contact the electric power company or an electrical repair shop. (2)Examine the cause and perform a professional repair. (3)Inspect the pump and remove the debris.
Pump stops after a predetermined length of time	(1)Protector has tripped after long hours of exposure operation. (2)Float case is clogged with debris, preventing it from operating.	(1)After the operation is restored, change it to an operation of approximately once every 30 minutes. (2)Remove debris by referring to the section on How to Clean.
Protector has tripped	(1)Equipment is not matched to the specifications of the pump or the equipment is set to improper values. (2)Motor is malfunctioning (seized or waterlogged). (3)A 50 Hz model is operated at 60 Hz.	(1)Replace the equipment with one with appropriate specifications or set it to correct values. (2)Repair or replace the pump. (3)Check the nameplate and replace the pump or the impeller.
Pump runs but does not pump water	(1)Pump is airlocked. (2)Pump or pipe is clogged inside. (3)Pipe is partially clogged or the valve is not operating properly.	(1)Stop the pump and restart, or clean the air valve. (2)Remove the clogged debris. (3)Remove the clogged debris, or repair or replace the valve.
Low pumping volume	(1)Impeller or the pump casing is excessively worn. (2)There is an excessive amount of piping loss. (3)A 60 Hz model is operated at 50 Hz.	(1)Repair or replace the affected parts. (2)Change the operation plan. (3)Check the nameplate and replace the pump or the impeller.
Pump generates noise or vibration	(1)Pipe support is loose. (2)Motor bearing is damaged. (3)Valve is too restricted.	(1)Secure the pipe support. (2)Replace the bearing. (3)Adjust the valve to an appropriate opening.

The information listed below is needed for repair or for contacting Tsurumi.

Product model	
Manufacturing number	
Purchase date	
Remarks	

Disposal of Product

Properly dispose of the product by disassembling it, presorting the contents, and sending them to the waste material treatment site.