

# CUBO PLANTER

Landscape Series indoor/outdoor

## SPECIFICATIONS

### Materials

8 gauge (1/8" thick) 5052 marine grade aluminum. Powder coated with ultra-durable exterior grade finishes.

Suitable for all weather and climates.

Optional water tight plugs for interior use.

### Dimensions

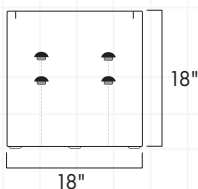
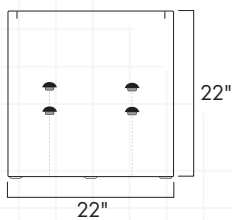
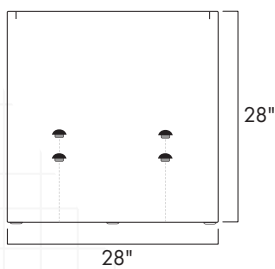
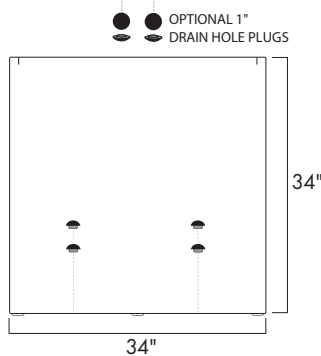
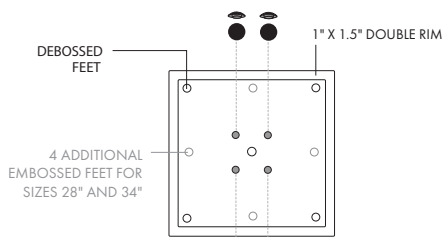

### Colours

Gun - Textured graphite grey  
Slate - Textured grey/brown  
Beach - Textured oatmeal beige  
Coffee - Textured matte brown

Polar - Smooth satin white  
Lava - Textured black  
Rust - Textured rust-like finish

### POWDER COATED FINISHES

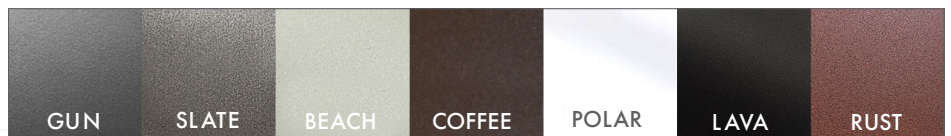

Custom colours available for special and larger wholesale orders

