



NSW-Z120354
User Manual



12" (316MM) SVC SUBWOOFER

SYSTEM EQUIPMENT

Thank you for your purchase and welcome to the world of Nakamichi! Please keep your original proof of purchase or invoice in a safe place in case of any warranty claims. Do also mail or register your warranty with the official Nakamichi service centers and/or agents to ensure that you are provided with the relevant technical support if required.

PRODUCT INFORMATION

Model	NSW-Z1203S4
Nominal Diameter	12" (Ø310 mm)
Nominal Impedance	4 ohm
Power Rating	300W RMS
Sensitivity(1w/1m)	86.5 ± 3 dB
Frequency Range	45~1.3k Hz
Voice Coil Diameter	Ø50 mm
Voice Coil Length	23 mm
Air Gap Height	8 mm
Magnet Dimension	Ø156 x 20 mm
Resonant Frequency, FS	30.1 ± 3 Hz
D.C. Voice Coil Resistance, Re	3.6 ohm
Mechanical Quality Factor, Qms	1.8
Electrical Quality Factor, Qes	0.44
Total Quality Factor, Qts	0.36
Equivalent Air Volume to Cms, Vas	47.3MPL
Mechanical Compliance, Cms	131M/N
BL Factor, Bl	8.9N/A
Effective Surface Area, Sd	50.2m M
Linear Excursion, Xmax	8 mm
Basket	Die Cast Iron
Cone and Dust Cap	Paper
Surround	Treated Foam
Voice Coil Wire	EISV
Voice Coil Bobbin	BASV
Magnet	Ferrite
Overall Diameter	Ø310mm
Bolt Circle Diameter	Ø300mm
Baffle Cutout Diameter	Ø296mm
Depth	129mm
Net Weight	Approx. 4.4 kg

IMPORTANT

- Read and understand all instructions before you use the apparatus. If damage is caused by failure to follow instructions, the warranty does not apply.
- Use only the supplied mounting hardware for a safe and secure installation.
- Do not continuously use the speaker system beyond the peak power handling capacity.
- Keep credit cards, watches, recorded tapes etc. with magnetic coding away from the speaker system to prevent damage caused by the magnets in the speakers.
- Clean the apparatus with soft, damp cloth. Never use substances such as alcohol, chemicals or household cleaners on the apparatus.

MOUNT ON REAR TRAY

You can mount the subwoofer on the rear tray.

- Set the wiring firmly on the floor of the vehicle, taking the utmost care not to break wires while installing.
1. Turn off the car ignition key.
IF the power is on, the click noise generated by the connection may damage the subwoofer.
 2. Cut out the mounting template from the packing box and paste it onto the location selected for mounting the subwoofer.
 3. Mark the cut-off hole and the 8 bolt holes.
 4. Cut out the marked area and drill the bolt holes.
 5. Connect the subwoofer to the amplifier.
 - Consult the diagram below. Be sure to connect corresponding terminals, i.e. "+" to "+" and "-" to "-". connection with reversed polarity will degrade the quality of production.

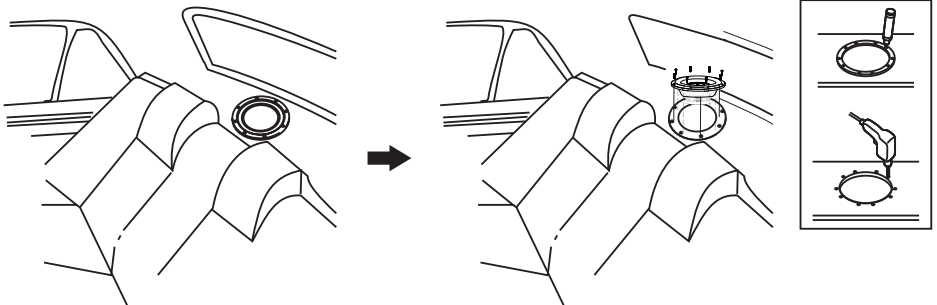

MOUNT ON REAR TRAY

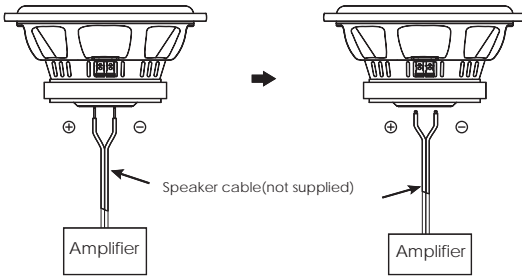

DIMENSIONS (UNIT: INCH/MM)

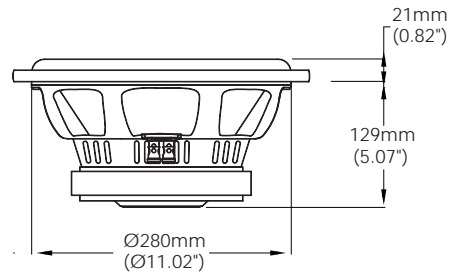
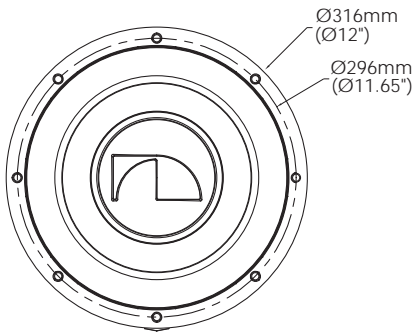

WHAT'S IN THE BOX

Check and identify the contents of your package:

1. 12" SVC Speaker (×1pc)
2. User manual (×1pc)
3. Installation template (×1pc)
4. Screws (×8pcs)

本機裝置

感謝您購買 Nakamichi 產品，歡迎光臨 Nakamichi 爲了使我們能更好地爲您服務，請保管好您的原始收據并填寫好保修卡。爲了您得到更多的技術支持，請您最好將保修卡頁碼的副本寄回 Nakamichi 指定的服務商。

產品信息

型號	NSW-Z1203S4
揚聲器類型	12" (Ø310 mm)
交流阻抗	4 ohm
額定功率	300W RMS
靈敏度	86.5 ± 3 dB
頻率範圍	45~1.3k Hz
音圈直徑	Ø50 mm
音圈長度	23 mm
間隙高度	8 mm
磁鐵尺寸	Ø156 x 20 mm
諧振頻率	30.1 ± 3 Hz
直流阻抗	3.6 ohm
機械品質因數	1.8
電氣品質因數	0.44
總阻尼因數	0.36
等效空氣容積	47.3MPL

機械合規性	131M/N
磁力係數	8.9N/A
有效表面積	50.2 mM
排線寬	8 mm
盆架	鐵盆架
紙盆與防生帽	紙制材料
振邊	泡沫
音圈線	線材
音圈骨架	黑鋁
磁鐵	鐵氧體
總直徑	Ø310mm
螺栓圓直徑	Ø300mm
當板切口直徑	Ø296mm
深度	129mm
淨重	大約 4.4 kg

包裝內物品

檢查並識別包裝中的物品，如發現有誤，請與銷售商聯繫：

1. 12寸单音圈喇叭 (1個)
2. 说明书 (1本)
3. 安裝模板 (1個)
4. 螺絲 (8顆)

重要信息

- 使用本裝置之前，請仔細閱讀並理解所有相關說明。如果由于未遵循說明而造成損害，則將不能享受保修。
- 只能使用隨附的安裝硬件，以確保安裝安全穩固。
- 切勿在超出峰值功率處理能力的情況下持續使用該揚聲器系統。
- 信用卡、手錶、錄音磁帶等具有磁性編碼的物件應遠離該揚聲器系統，以免揚聲器內部的磁鐵帶來損壞。
- 用柔軟的濕布清潔本裝置。切勿使用酒精、化學品或家用清潔劑等物質清潔本裝置。

安裝在後座托盤

您可將低音揚聲器安裝在後座托盤。（把線牢固在車輛的地板上，不能損壞安裝線路）

1. 閉汽車的點火鑰匙。

如果電源為接通狀，則電源連接所產生的震動聲可能會對低音揚聲器造成損壞。

2. 從包裝盒中取出安裝模版，將模版貼在安裝揚聲器的位置上。

3. 標記好定點孔和8個螺栓孔

4. 切除標記部分，並鎖開螺栓孔

5. 將低音揚聲器連接至音器。

參照下圖，一定要正確連接相應的端子，即左同左，右同右和+同+，-同-端子。

極性反置可導致音質下降。

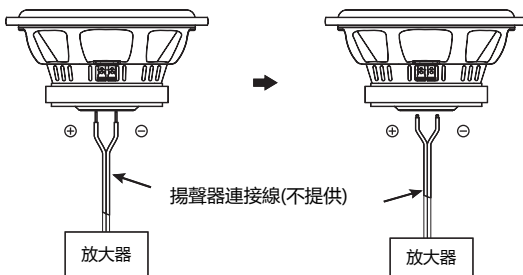
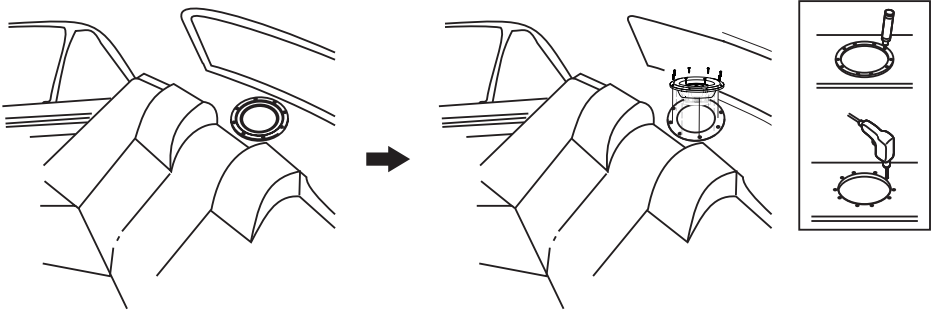

尺寸 (單位 : 英寸/毫米)

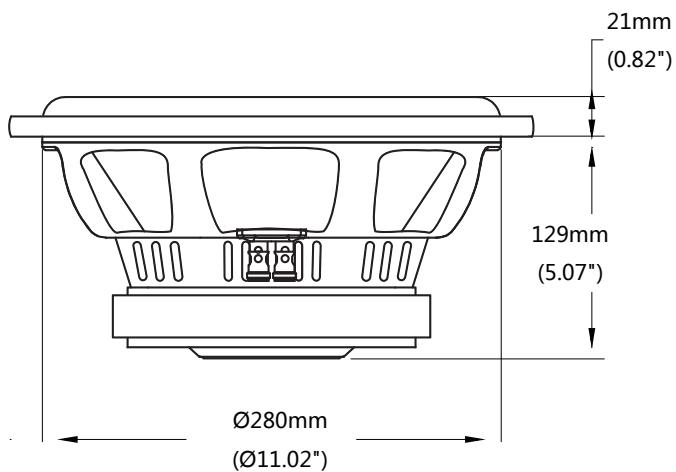
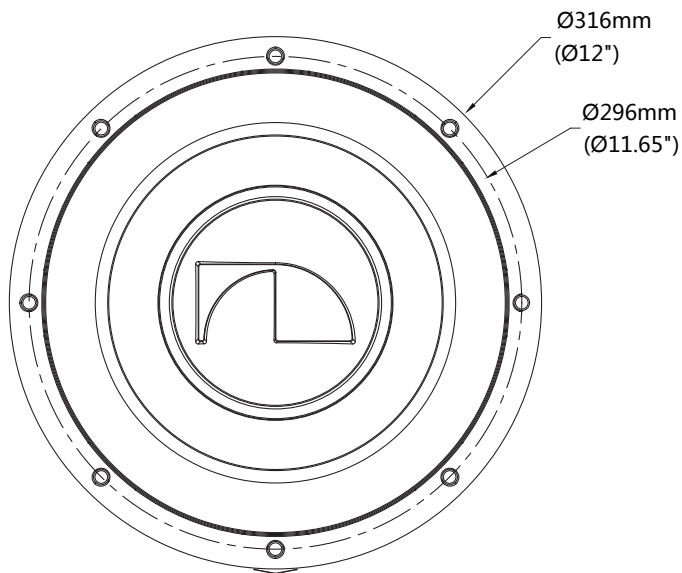

CONNECT WITH US

 [nakamichicaraudio.com](https://www.nakamichicaraudio.com)

 [Nakamichi.Global](https://www.facebook.com/Nakamichi.Global)

 [nakamichi.caraudio](https://www.instagram.com/nakamichi.caraudio)