



NGXA80.4

4-Channel Bridgeable Power Amplifier

User Manual

www.nakamichicaraudio.com

INTRODUCTION

INTRODUCTION	2 EN
ACCESSORY LIST	2 EN
SPECIFICATIONS	2 EN
DIMENSIONS	3 EN
PANEL CONTROLS AND FEATURES	4 EN
WIRING DIAGRAM	5 EN
PRECAUTIONS	6 EN
FUSE REPLACEMENT	6 EN
PROTECTION CIRCUIT	6 EN
WIRING INSTRUCTIONS	7 EN
Power Connection	
Ground Connection	
Remote Turn-On Connection	
Speaker Connections	
POWER CONNECTION LEADS	8 EN
Notes On The Power Supply	
OPERATION	9 EN
Gain = Input Level Control	
X-Over Frequency Control	
Crossover Switch	
Bass Boost Control	
HOW TO PROCEED IN CASE OF FAULTS	10 EN
No Function	
No Sound	
No Sound / Red LED Protection Shines	
Poor Sound Quality (Distortions)	
No Stereo Sound And A Weak Bass	
INTERFERENCE	10 EN

INTRODUCTION

Thank you for your purchase, and welcome to Nakamichi! In order to enjoy the better service from us, please keep your original invoice well and complete. You'd better post the copy of back to the appointed service agent of Nakamichi so that you may get more technical support.

ACCESSORY LIST

1. User Manual	1pc
2. Amplifier	1pc
3. Mounting Screw ($\varnothing 4$ x20mm)	4pcs
4. Wrench (2mm and 4mm)	2pcs

SPECIFICATIONS

N-power Output @ 4 Ohm	75W x 4
N-power Output @ 2 Ohm	110W x 4
N-power Output @ 4 Ohm Bridged	250W x 2
Max Power	2000W
Frequency Response	15Hz -30KHz
Input Sensitivity	200mV to 6V
Signal To Noise Ratio	≥ 90 dB
T.H.D.	$\leq 0.2\%$
Low Pass Cross Frequency	50Hz - 3KHz
High Pass Cross Frequency	20Hz - 3KHz
Bass Boost	0dB 6dB 12dB
Remote Subwoofer Level	No
Minimum Impedance	20K
Fuse Size	30A x 2
Net Weight	Approx. 3.1 kg
Dimensions (L x H x W)	389x183x55mm

Dimensions(Unit: mm)

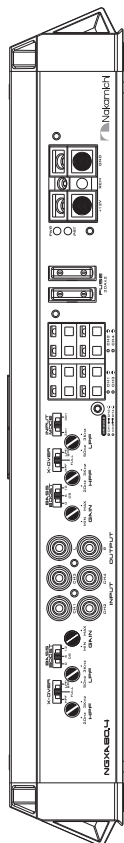
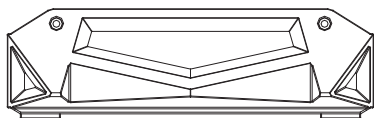
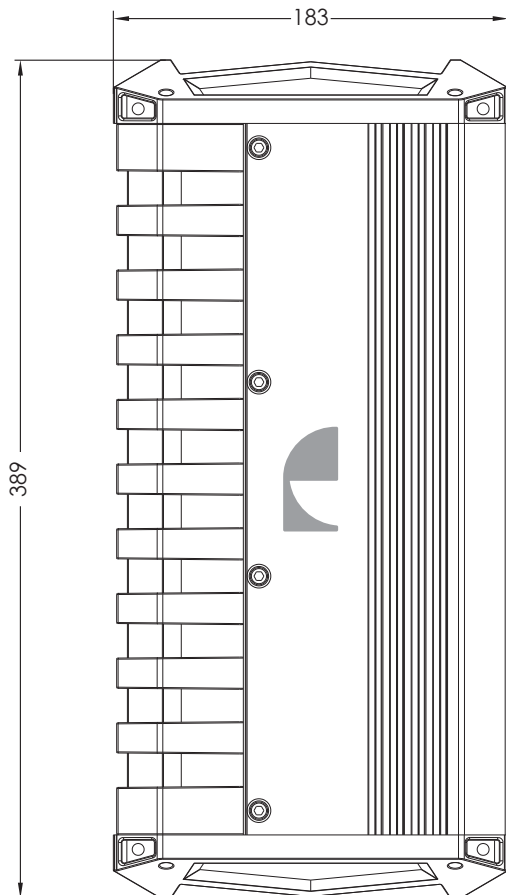
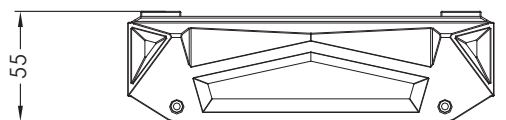

Panel Controls and features

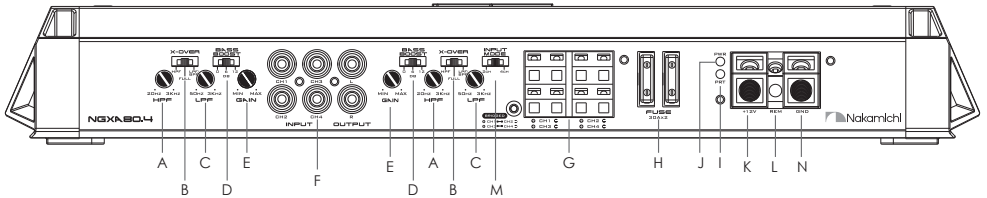

A. HIGH PASS CROSS FREQUENCY

Controls the frequency of the power amplifier of high frequency reduction to common denominator is 20Hz to 3KHz.

B. X-OVER CONTROL

Depending on the selected switch setting the amplifier operates in fullrange, highpass or Lowpass mode.

C. LOW PASS CROSS FREQUENCY

Controls the frequency of the power amplifier of Low frequency reduction to common denominator is 50Hz to 3KHz.

D. BASS BOOST LEVEL KNOB

The Bass BOOST feature will increase the sound level in the bass frequencies.

E. GAIN CONTROL

The gain control will match the amplifier's sensitivity to the source unit's signal voltage.

F. LOW LEVEL RCA INPUT

These RCA input jacks connect with your source unit's RCA Low level outputs or via optional adapter with your source unit's speaker high level outputs. The use of high quality twisted pair car audio cables is recommended to avoid the possibility of disturbance to the audio signal.

G. SPEAKER CONNECTIONS

connect speakers/subwoofers to these terminals. Be sure to check wire for proper polarity. Never connect the speaker cables to chassis ground.

H. Fuse

The fuses protect the car should a catastrophic problem occur in the amp. Always replace fuses with the same size fuse.

I. Protection indicator

this red LED will light up and will be flashing if there is a fault presented to the amplifier. Please disconnect the amplifier and resolve the fault before reconnecting the amplifier.

J. Power indicator

this LED will light up when the amplifier works properly.

K. + 12V = POWER SUPPLY

connect this terminal through a fuse or circuit breaker to the positive terminal of the vehicle battery or the positive terminal of an isolated audio system battery.

L. REM(ON/OFF) REMOTE CONTROL

when using Hi-Input, the amp can detect the DC offset from the high level input signal to auto turn ON/OFF. when the amp turns on, the REM terminal will output +12V DC to control the other device turn ON/OFF. REM IN: When using Low level input, the amp's remote should be connected to the remote of the source unit. The head unit controls the amp turn ON/OFF.

N. GND(-) = GROUND CONNECTION

Connect this cable directly to the frame of the vehicle. make sure the metal frame has been stripped of all paint down to the bare metal. Use the shortest distance possible. It is always a good idea to replace the vehicle battery ground terminal or any other factory ground points.

M. INPUT MODE SWITCH

If your head unit has one single pair of rca outputs, input them in to the amplifier's channel 1 and 2 input jacks and set the input mode switch to 2ch. The amplifier's preamp circuitry will automatically mix all the channels and output will occur on all 4 channels.

If your head unit has two pairs of rca outputs, input front left and front right in to the amplifier's channels 1 and 2 input jacks. Rear left and rear right in to amplifier's channels 3 and 4 input jacks. Set the input mode switch to 4ch. The amplifier's preamp circuitry will automatically mix all the channels and output will occur on all 4 channels.

WIRING DIAGRAM

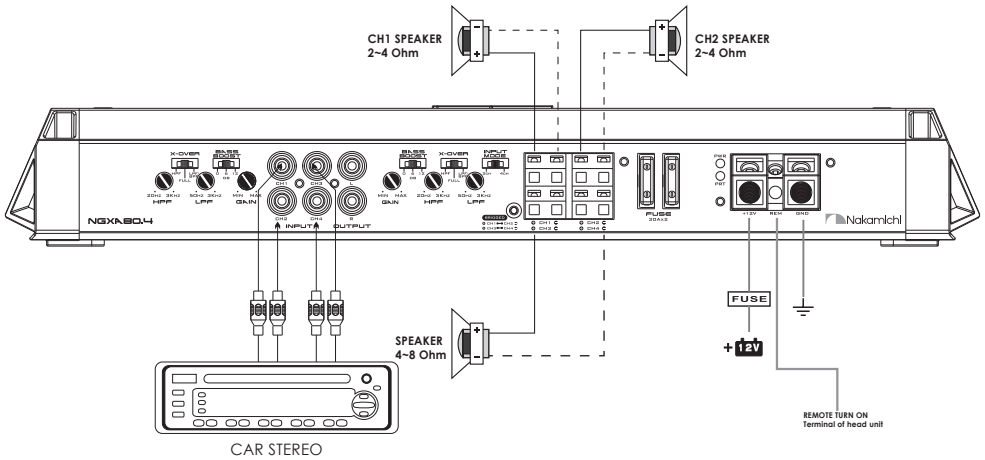
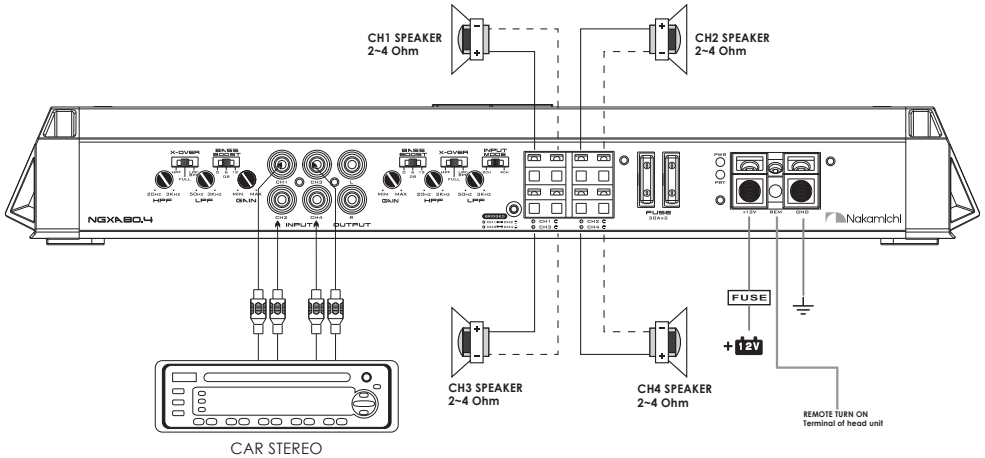

PRECAUTIONS

- This unit is designed for negative ground 12 Volts DC operation only.
- Use speakers with an impedance of 2Ω or 4Ω (4Ω to 8Ω when used as bridged amplifier)
- Avoid installing the unit where:
 - It would be subject to high temperatures, such as from direct sunlight or hot air from the heater.
 - It would be exposed to rain or moisture.
 - It would be subject to dust or dirt.
- If your car is parked in direct sunlight and there is a considerable rise in temperature inside the car, allow the unit to cool off before operation.
- When installing the unit horizontally, be sure not to cover the heatsink fins with the floor carpet.
- If this unit is placed too close to the car radio, an interference may occur. In this case, separate the amplifier from the car radio.
- This power amplifier employs a protection circuit to protect the transistors and speakers if the amplifier malfunctions.
- Do not attempt to test the protection circuits by covering the heatsink or connecting improper loads.
- Do not use the unit with a weak auto battery as its optimum performance depends on a normal battery supply voltage.
- For safety reasons, keep the volume of your car audio system moderate so that you can still hear normal traffic sounds outside your car.

FUSE REPLACEMENT

If the fuse blows, check the power connection and replace the fuse. If the fuse blows again after replacement, there may be an internal malfunction. In this case, consult your dealer.

WARNING: Use the specified amperage fuse. Use of a higher amperage fuse may cause serious damage.

PROTECTION CIRCUIT:

This amplifier is provided with a protection circuit which operates in the following cases when:

- the unit is overheated.
- the speaker terminals are short circuited.

WIRING INSTRUCTIONS

POWER CONNECTION

The battery terminal (BATT) must be connected directly to the positive terminal of the vehicle battery to provide an adequate voltage source and minimize noise. Connecting the battery terminal lead to any other point (such as the fuse block) will reduce the power output and may cause noise and distortion. Use only #4 gauge or thicker (smaller gauge#) wire for this lead and connect it to the terminal of the battery after all other wiring is completed.

GROUND CONNECTION

The ground terminal (GND) connection is also critical to the correct operation of the amplifier. Use a wire of the same gauge as the power connection (#4 or thicker) and connect it between the ground terminal(GND) of the amplifier and a metal part of the vehicle close to the mounting location. This wire should be as short as possible and any paint or rust at the grounding point should be scraped away to provide a clean metal surface to which the end of the ground wire can be screwed or bolted.

REMOTE TURN-ON CONNECTION

The amplifier is turned on by applying +12V to the remote turn-on terminal (REM). The wire lead to this terminal should be connected to the "Auto-Antenna" lead from the car stereo which will provide the +12V only when the car stereo is turned on . If the car stereo does not provide an "Auto-Antenna" lead, the remote turn-on lead may be wired to an "Accessory" or "Radio" terminal in the car's fuse block. This will turn the amplifier on and off with the ignition key, regardless of whether the car stereo is on or off. The remote turn-on lead does not carry large currents. So #20 gauge wire may be used for this application.

SPEAKER CONNECTIONS

Depending on the type and number of speakers used with the amplifier wire them to the speaker terminals as per the appropriate wiring diagram. For most applications # 18 gauge wire should be used for the speaker leads but in no case thinner than # 20 gauge. For leads in excess of 10 feet #16 gauge is recommended. When wiring the speakers, pay careful attention to the polarity of the terminals on the speakers and make certain they correspond to the polarity of the corresponding terminals on the amplifier. Do not ground any speaker leads to the chassis of the vehicle.

POWER CONNECTION LEADS

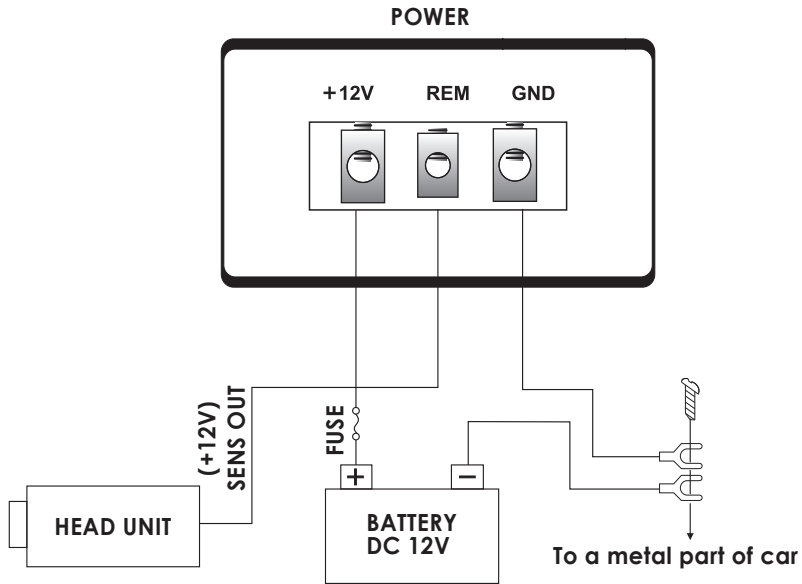

NOTES ON THE POWER SUPPLY:

- Connect the +12V power input lead only after all other leads have been connected.
- Be sure to connect the ground wire of the unit securely to a metal part of the car.
- A loose connection may cause a malfunction of the amplifier.
- REM: The unit is turned on by applying +12 Volts to this terminal. This terminal does not draw heavy current like the tow Power Terminals so a thinner connecting wire is acceptable. Standard 18 GAUGE is fine and the standard color is yellow. If the radio is equipped with a Power Antenna control wire, it can drive this terminal. If the Power Antenna wire is already in use, you can still splice into it. With this method, the unit will turn on automatically with the radio.
- Use the power supply lead with a fuse attached whose value is the same as original fuse.
- Place the fuse in the power supply lead as close as possible to the car battery.
- During a full power operation, Maximum current will run through the system. Therefore make sure that the leads to be connected to the +12V and GND terminals of the unit respectively must be larger than 10-Gauge (AWG.10).

OPERATION

GAIN = INPUT LEVEL CONTROL

● The input level control allows the system to work well within a wide range of output level. Choose the adjustment in the way that you achieve a sound most possibly without any distortion. As a guideline the following procedure is recommended:

–If you use several amplifiers, the adjustment has to be made for each set separately. Tune in the volume of your car radio to 2/3 of the maximum volume. Now turn the gain control of the amplifier from "Min" to "Max" direction until you can hear distortions. Then turn the gain a little back until the noise disappear. The gain control adjustment is finished now.

ATTENTION: If you use 2 Ohm speakers in stereo mode, or 4 Ohm speakers in bridge mode and the overload protection is triggered out, turn the gain control to "Min" direction, until the operation is free of trouble.

X-OVER FREQUENCY CONTROL

- When the crossover control is in the Low-Pass position, this control becomes active allowing you to select your crossover point.
- When the crossover control is in the High-Pass position, this control becomes active allowing you to select your crossover point.

CROSSOVER SWITCH

Full: full range frequency.

Low pass: the lower frequency under setting point can be pass.

High pass: the higher frequency above setting point can be pass.

BASS BOOST CONTROLS

This amplifier has Bass controls for making good sound combination.

HOW TO PROCEED IN CASE OF FAULTS

No Function:

- The connection cable is not connected correctly (=terminal +12V/GND/REM). Ensure that all connections and mechanic contact and that the jacket has been removed. The fuse is defective-pay attention to the correct value of a new fuse!

No Sound :

- Speaker cable or speaker plug are not connected correctly.

No Sound / Red LED Protection is on:

- The plus and minus wires of the speaker cable have contact, thus eliminate the short circuit. If you use a 2 Ohm speaker in stereo mode, a 4 Ohm speaker in bridge mode or tri-mode and the set is overloaded, then turn the gain control to "min" until the operation is free of trouble.

Poor Sound Quality (Distortions) :

- The speakers are overloaded, therefore turn down the volume level and check the volume control positions.

No Stereo Sound And A Weak Bass :

- Speaker cables (+) and (-) are mixed up, unit wired out of phase.

INTERFERENCE

All cables can source and create interference. The power cable and Cinch/RCA audio cable are very prone to interference; the remote cables are less prone. There is often interference caused by the generator (piping), ignition (cracking) or other car electronic parts. Most of these problems can be eliminated by correct and careful cabling. In doing so, here are the following guidelines:

- Use only a screened audio cable for the wiring between "low level in" of the amplifier and RCA or DIN output of the radio.
- Lay the signal, speaker and power cables separately with enough distance from one another and also from each other car cable. If not possible, you can lay the circuit and ground cable together with the serial cables. Audio and speaker cable should be as far away from these as possible. The REM cable to the automatic antenna output of the radio can be laid together with the signal cables.
- Avoid ground loops by laying the ground wiring of all components to a center point in a starlike way. You can find the best central point in measuring the voltage directly at the battery. Now compare this voltage value with the chosen ground point and the(+) terminal of the amplifier. If measured voltage is only slightly different, you've found the correct central. Otherwise you have to look for another point. You should measure with the ignition point for earth being switched on and additionally switched on consumers (rear window heating and light).
- If there are pickups from external electrical sources into the speaker cables, divide the core leads and twist them together.
- If there are noises from the car electrics, add an interference suppression choke into the power wiring.
- If there are humming noises, use thicker ground cables or add further ground cables to the chassis.
- To reduce contact resistance and bad and loose contacts, please solder the cable ends or use multi core cable ends, spade terminals or others. Gold Plated spade terminal are free of corrosion and have the lowest contact resistance.
- Should all these measures be without any success, the use of a ground loop isolator may solve the problem.



www.nakamichicaraudio.com